

LOC	DIST	REV	DESCRIPTION	DATE	OWN	APVD
GP	00	A	RELEASE PER ECO-16-002978	3MAR2016	RG	SH

- 1. CAGE ASSEMBLY MATERIAL: NICKEL SILVER, 0.25 THICK  
 HEAT SINK MATERIAL: ALUMINUM  
 HEAT SINK CLIP MATERIAL: STAINLESS STEEL  
 EMI SPRING MATERIAL: COPPER ALLOY  
 EMI GASKET MATERIAL: CONDUCTIVE RUBBER, UL 94V-0 RATED  
 EMI GASKET PLATE MATERIAL: STAINLESS STEEL
- 2. PITCH BETWEEN PORTS OF ONE 1X4 CAGE ASSEMBLY.
- 3. SPACING BETWEEN CAGES ON THE SAME PC BOARD, TO BE SPECIFIED BY CUSTOMER, MUST COMPLY WITH MINIMUM DIMENSIONS SHOWN.
- 4. REFERENCE APPLICATION SPEC 114-13217 FOR RECOMMENDED DRILL HOLE DIAMETER AND PLATING THICKNESS.
- 5. DATUMS AND BASIC DIMENSIONS ESTABLISHED BY CUSTOMER.
- 6. DIMENSION F IS THE NOMINAL THICKNESS OF CUSTOMER SUPPLIED PC BOARD,  
 SINGLE SIDED PC BOARD MINIMUM THICKNESS = 1.45mm  
 DOUBLE SIDED PC BOARD MINIMUM THICKNESS = 5.0mm PER CUSTOM.
- 7. HEAT SINKS, LIGHT PIPES, AND HEAT SINK CLIPS SHIPPED ASSEMBLED TO CAGE ASSEMBLY. CAGE ASSEMBLY MAY BE PRESSED INTO THE PCB AS SHIPPED.
- 8. DATUM -A- IS TOP SURFACE OF PC BOARD.
- 9. DIMENSION APPLIES WITH MODULE INSERTED IN CAGE.
- 10. UNPLATED THRU HOLE.

- 11. MATES WITH QSFP MSA COMPATIBLE TRANSCEIVER.
- 12. SURFACE TRACES PERMITTED WITHIN THIS AREA EXCEPT WHERE CAGE STANDOFFS, SHOWN IN DETAIL A, CONTACT PC BOARD.
- 13. BASELINE FOR THESE DIMENSIONS IS THE CENTER OF COMPLIANT PIN HOLE.
- 14. DATE CODE (YYWW) MARKED ON TOP OF CAGE AND CONCEALED BY HEAT SINKS APPLIES TO CAGE ASSEMBLY ONLY.
- 15. REFERENCE APP SPEC 114-13217 FOR GASKET THICKNESS CALCULATION.
- 16. EMI SPRING FINISH: TIN PLATING OVER NICKEL  
 HEAT SINK FINISH: ANODIZED OR NICKEL PLATING.

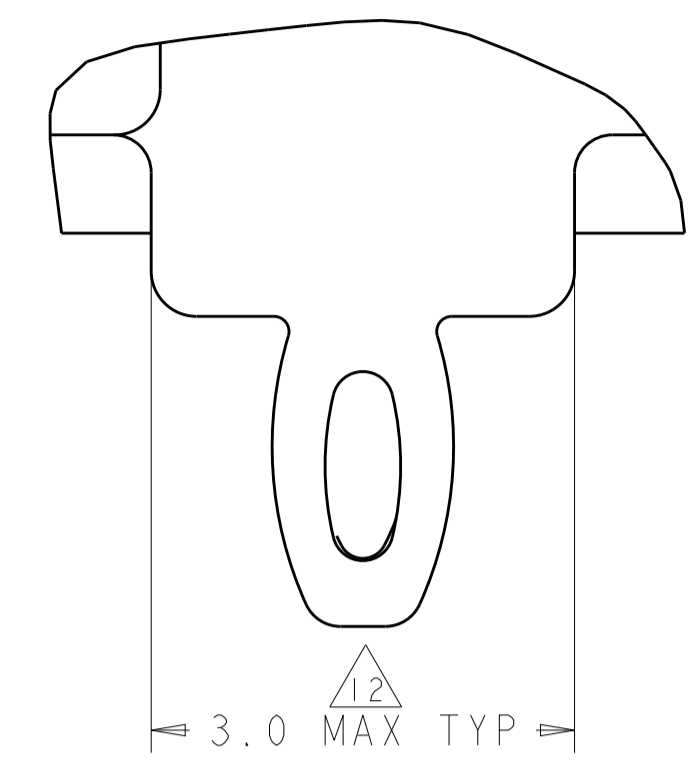

DETAIL A  
 SCALE 20:1

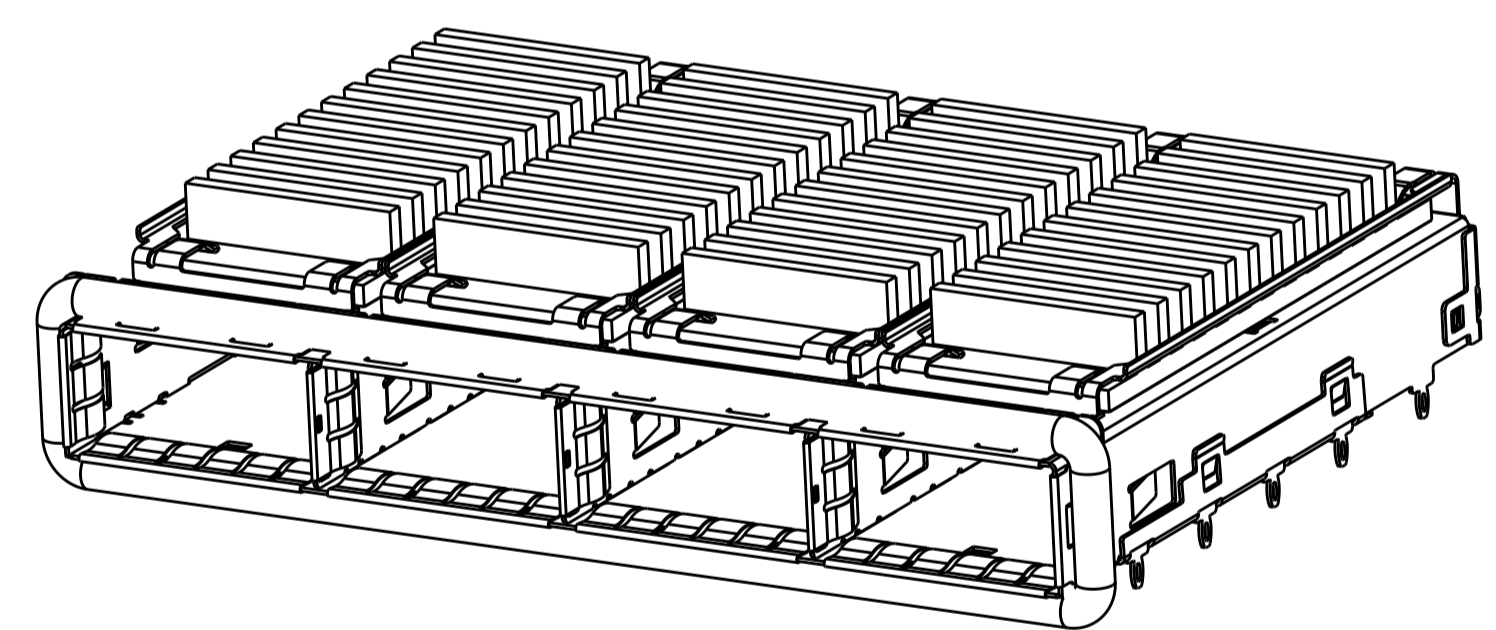
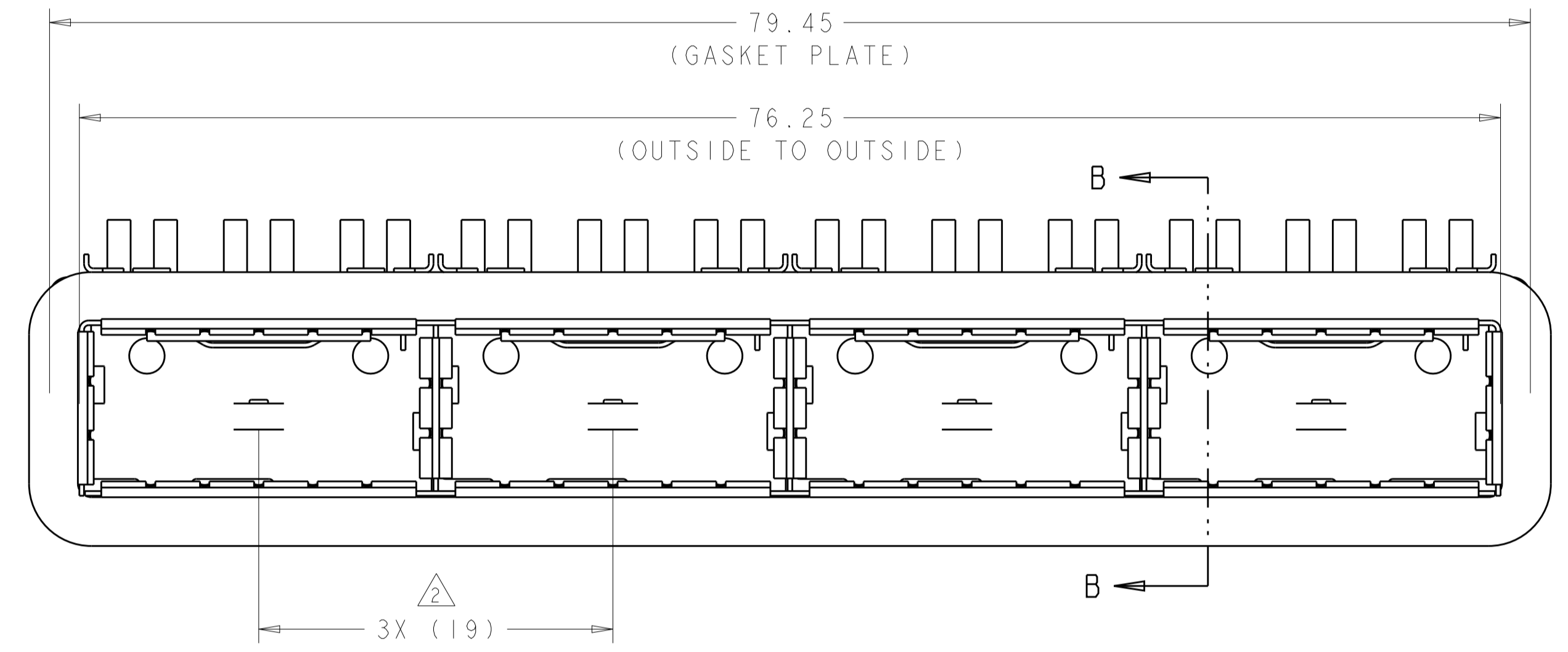
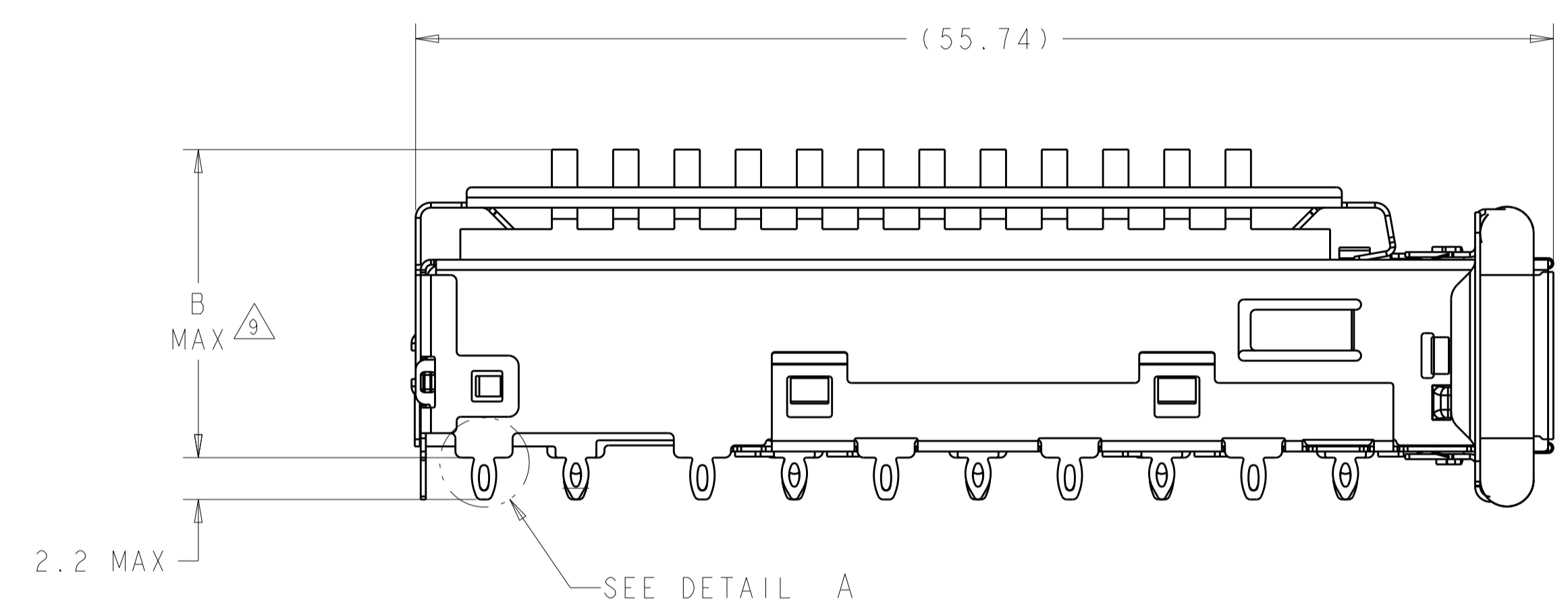

2170287-4, 2170287-5, 2170287-6  
 SCALE 2:1

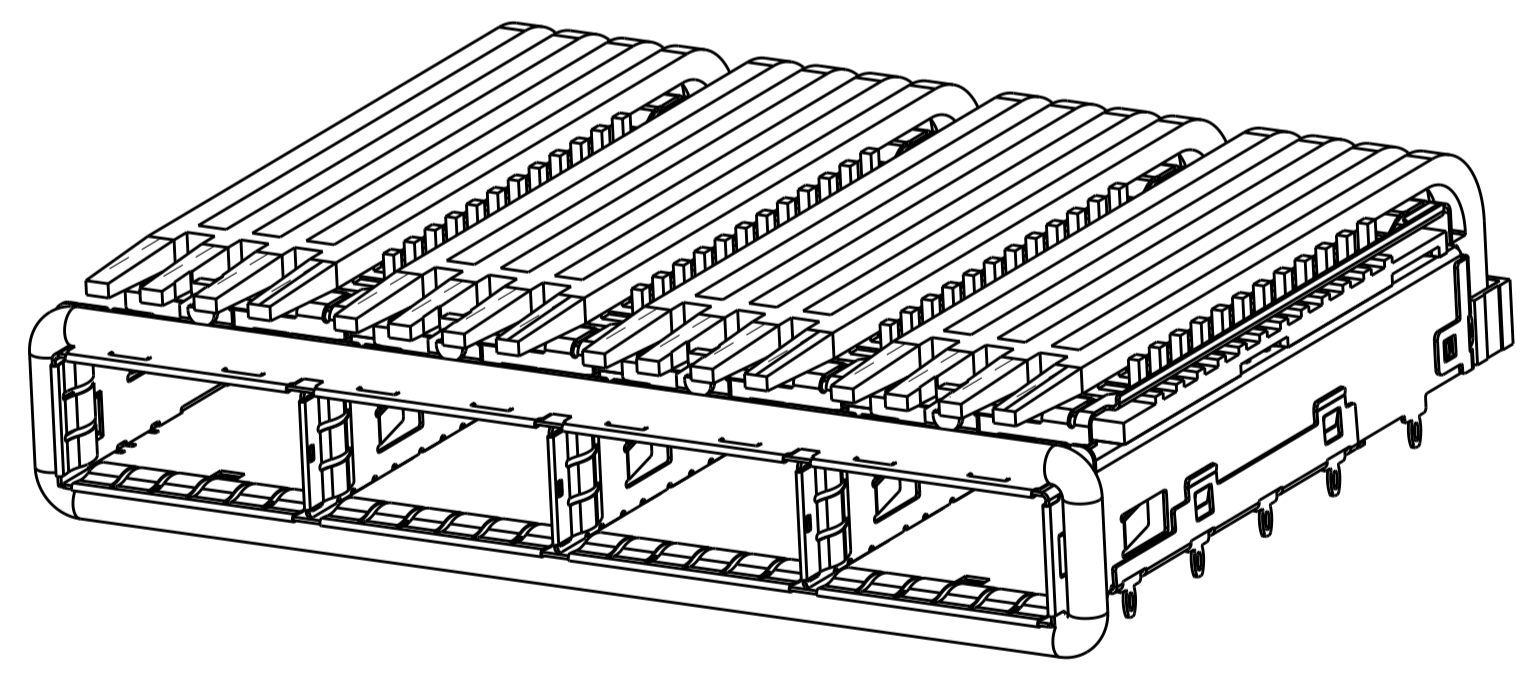

1-2170287-0  
 SCALE 2:1

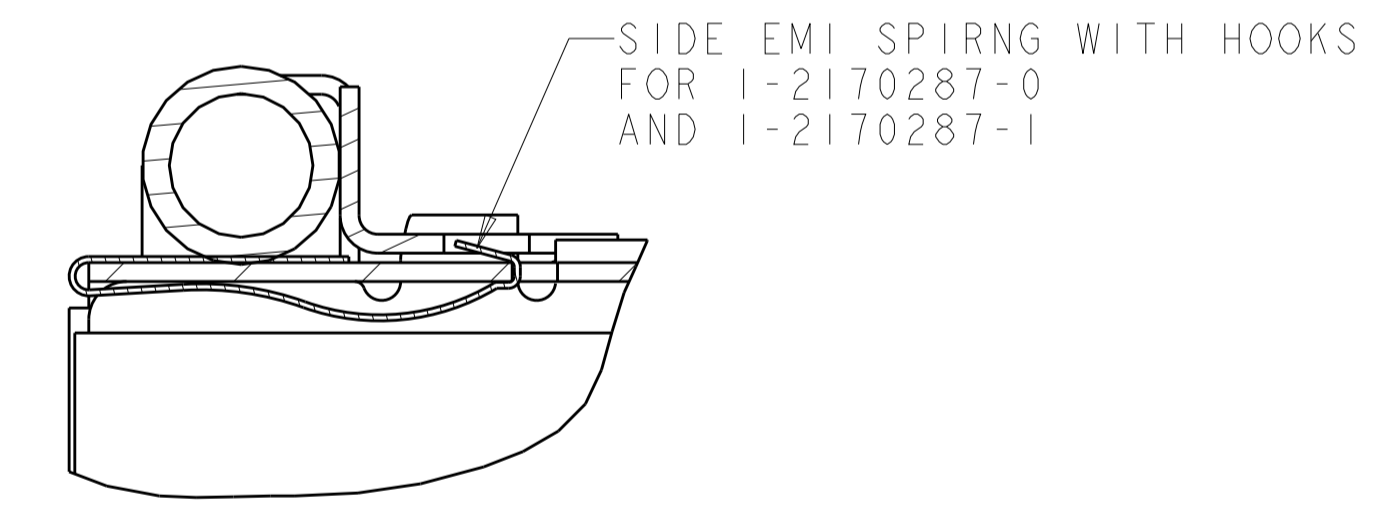

SECTION B-B  
 SCALE 10:1

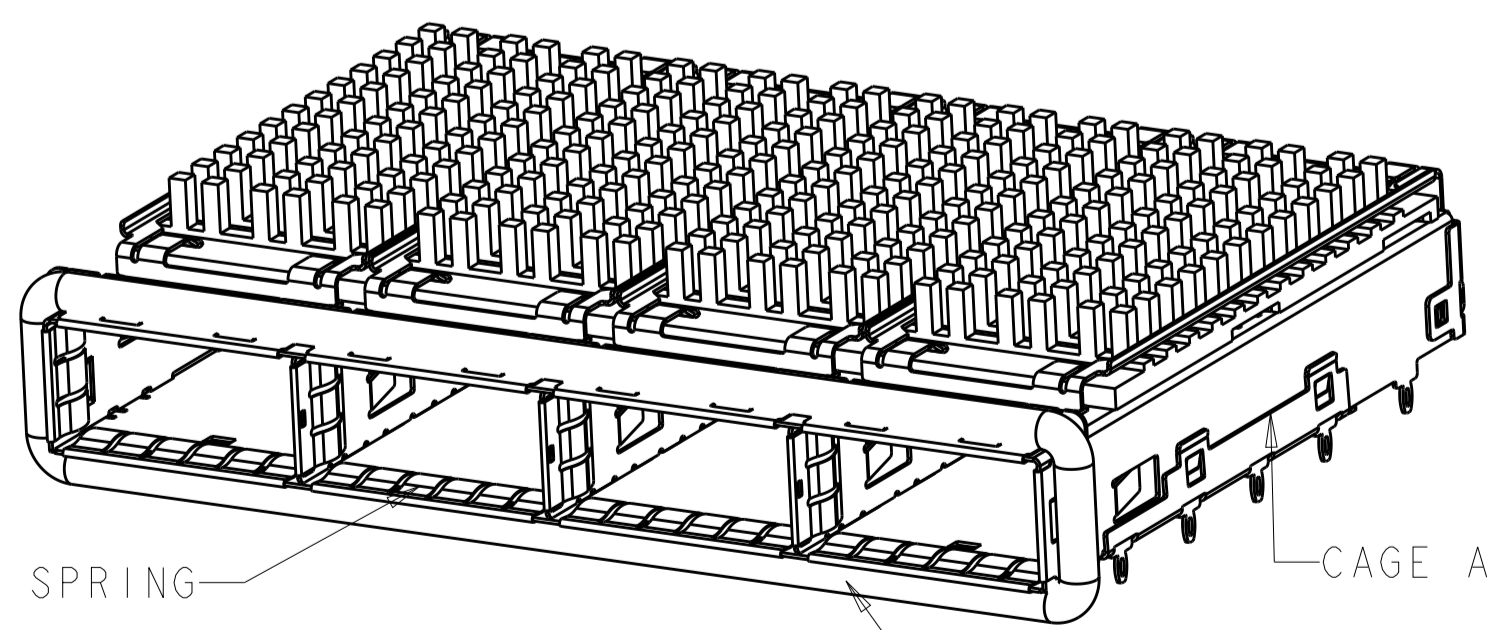

2170287-1, 2170287-2, 2170287-3  
 SCALE 2:1

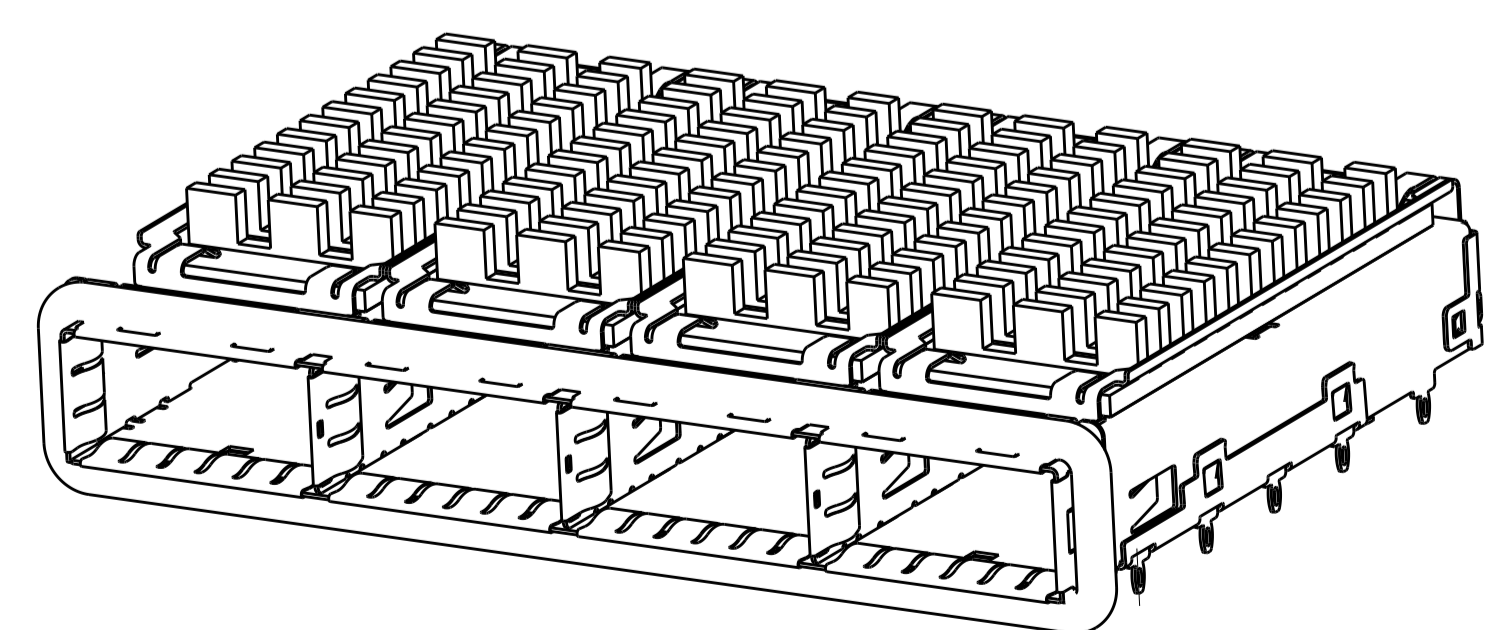

2170287-7, 2170287-8, 2170287-9  
 SCALE 2:1

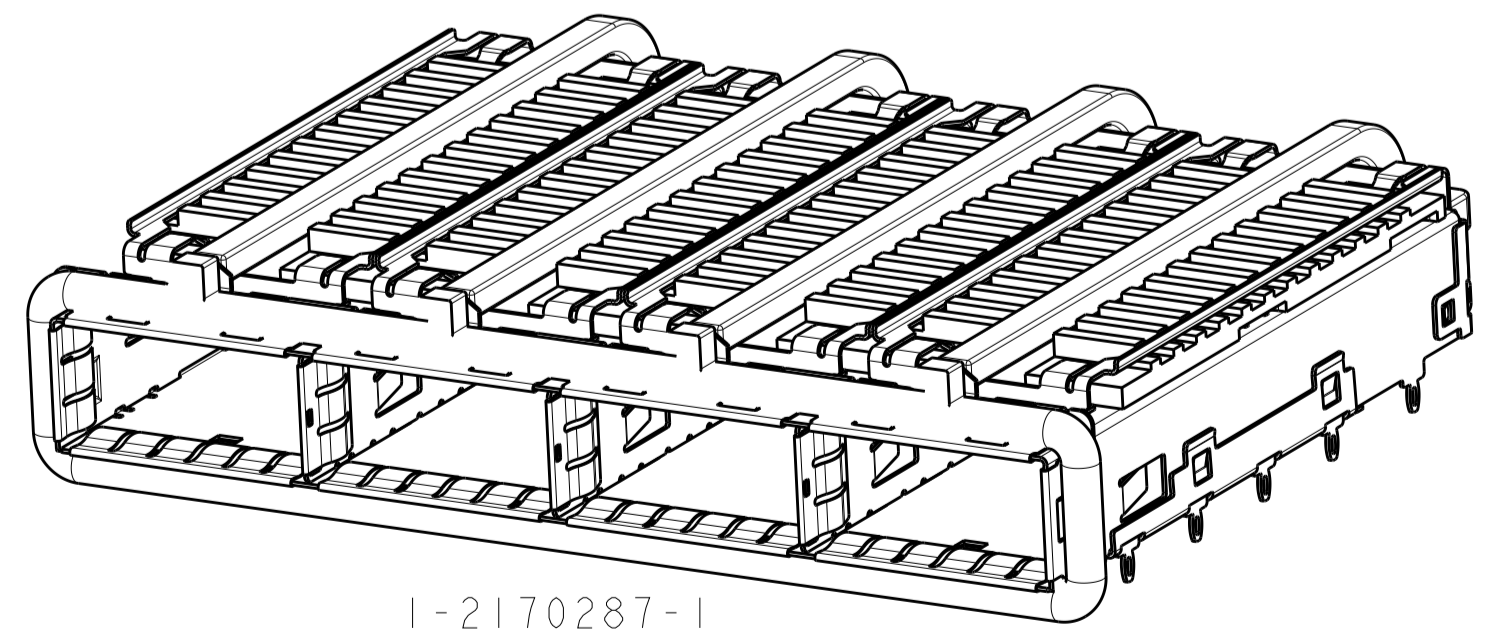

1-2170287-1  
 SCALE 2:1

13.7	PCI(FIN TYPE)	1-2170287-1
15.0	CUSTOMIZED HEAT SINK	1-2170287-0
23.0	NETWORKING(FIN TYPE)	2170287-9
16.0	SAN(FIN TYPE)	2170287-8
13.7	PCI(FIN TYPE)	2170287-7
23.0	NETWORKING(FIN TYPE)	2170287-6
16.0	SAN(FIN TYPE)	2170287-5
13.7	PCI(FIN TYPE)	2170287-4
23.0	NETWORKING(PIN TYPE)	2170287-3
16.0	SAN(PIN TYPE)	2170287-2
13.7	PCI(PIN TYPE)	2170287-1
B	HEAT SINK PROFILE	PART NUMBER

THIS DRAWING IS A CONTROLLED DOCUMENT.

DIMENSIONS:	TOLERANCES UNLESS OTHERWISE SPECIFIED:	OWN: RINSEN SUN 29FEB2012	CHK: DENNY ZHU 29FEB2012	APVD: ALEY CAI 29FEB2012	NAME: 1X4 CAGE ASSEMBLY, THRU BEZEL, W/ELASTOMERIC GASKET AND HEAT SINKS, QSFP
mm	0 PLC ±0.35 1 PLC ±0.25 2 PLC ±0.25 3 PLC ±0.25 4 PLC ±0.25 ANGLES ±	PRODUCT SPEC: 108-2286	APPLICATION SPEC: 114-13217	SIZE: CAGE CODE DRAWING NO: A100779C=2170287	RESTRICTED TO: -
MATERIAL:	FINISH:	WEIGHT:	CUSTOMER DRAWING	SCALE: 4:1	SHEET 1 OF 8 REV A

4805 (3/11)

LOC	DIST	REVISIONS					
GP	00	P	LTN	DESCRIPTION	DATE	DMN	APVD
-	-	-	-	SEE SHEET 1	-	-	-

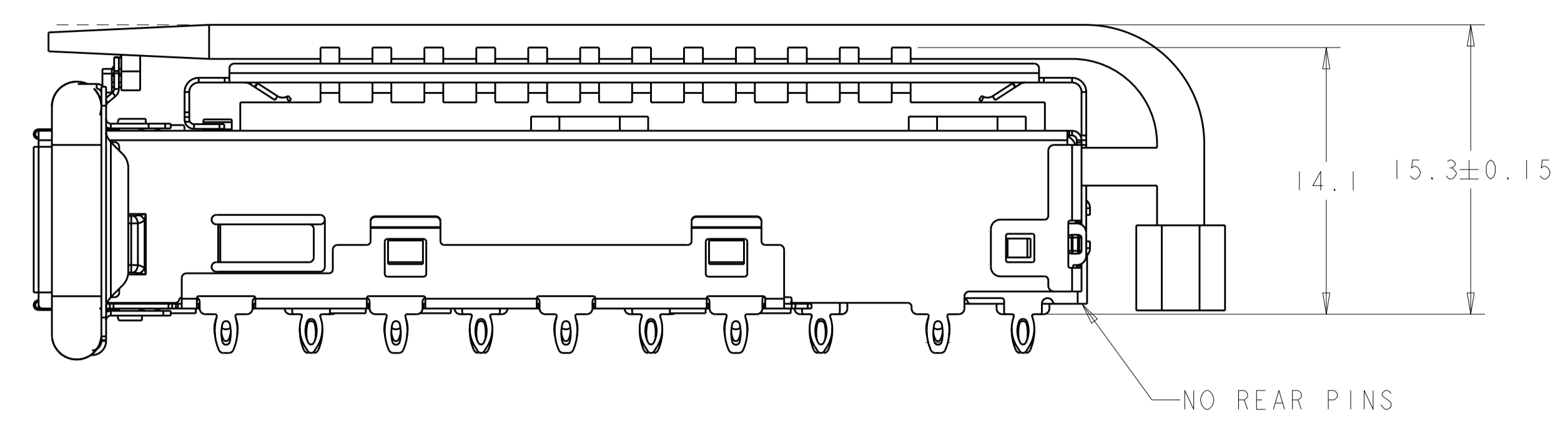
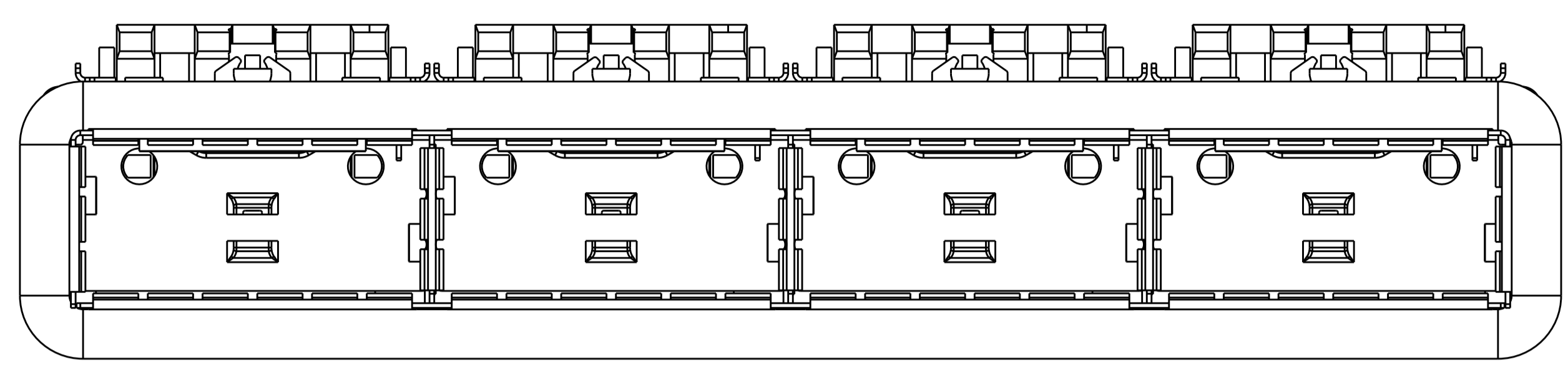

1-2170287-0 shown  
SCALE 4:1

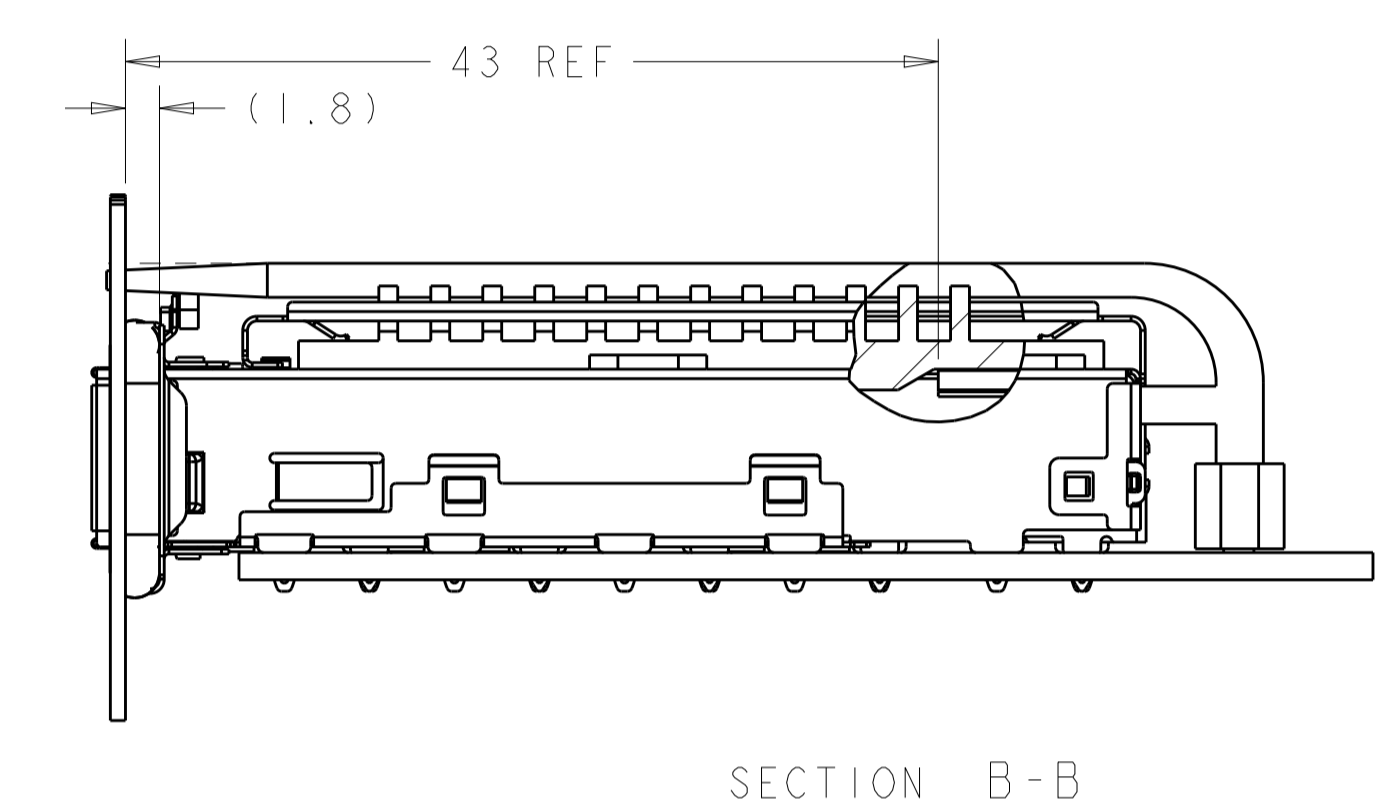
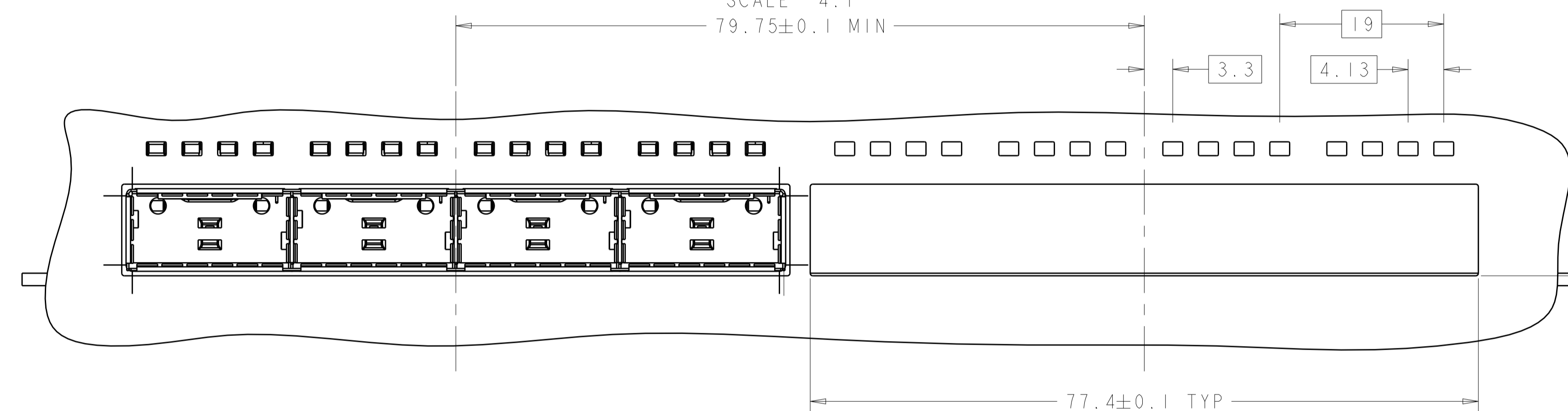

1-2170287-0  
ONE SIDED CONFIGURATION  
SCALE 5:2

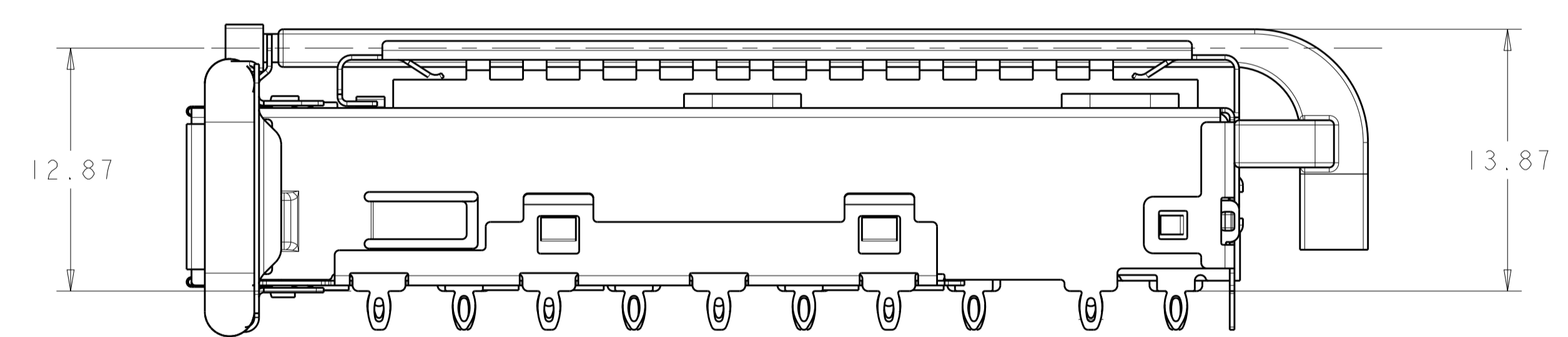
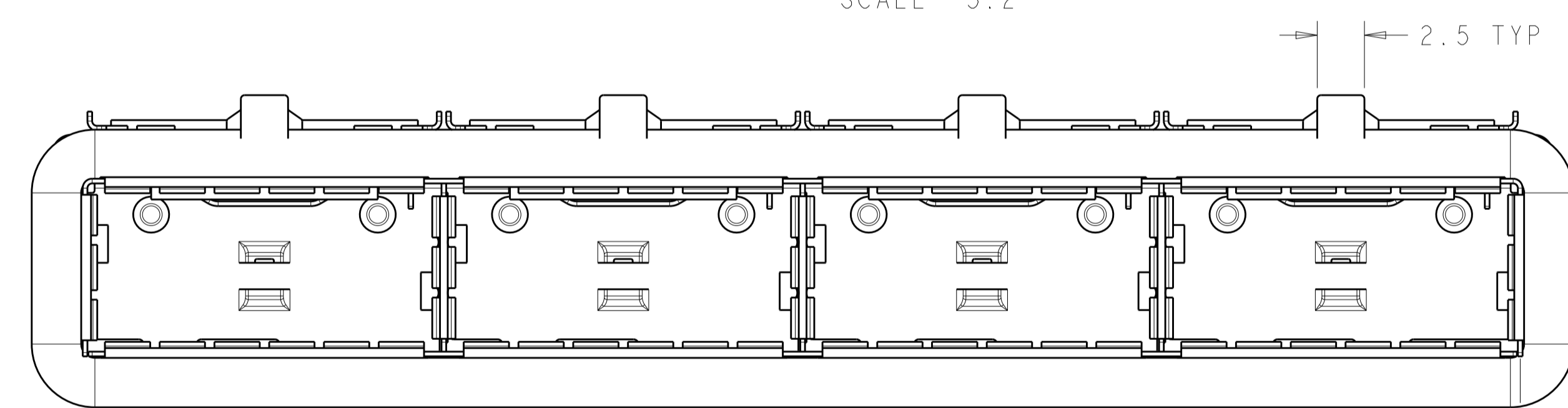

1-2170287-1 SHOWN  
SCALE 4:1

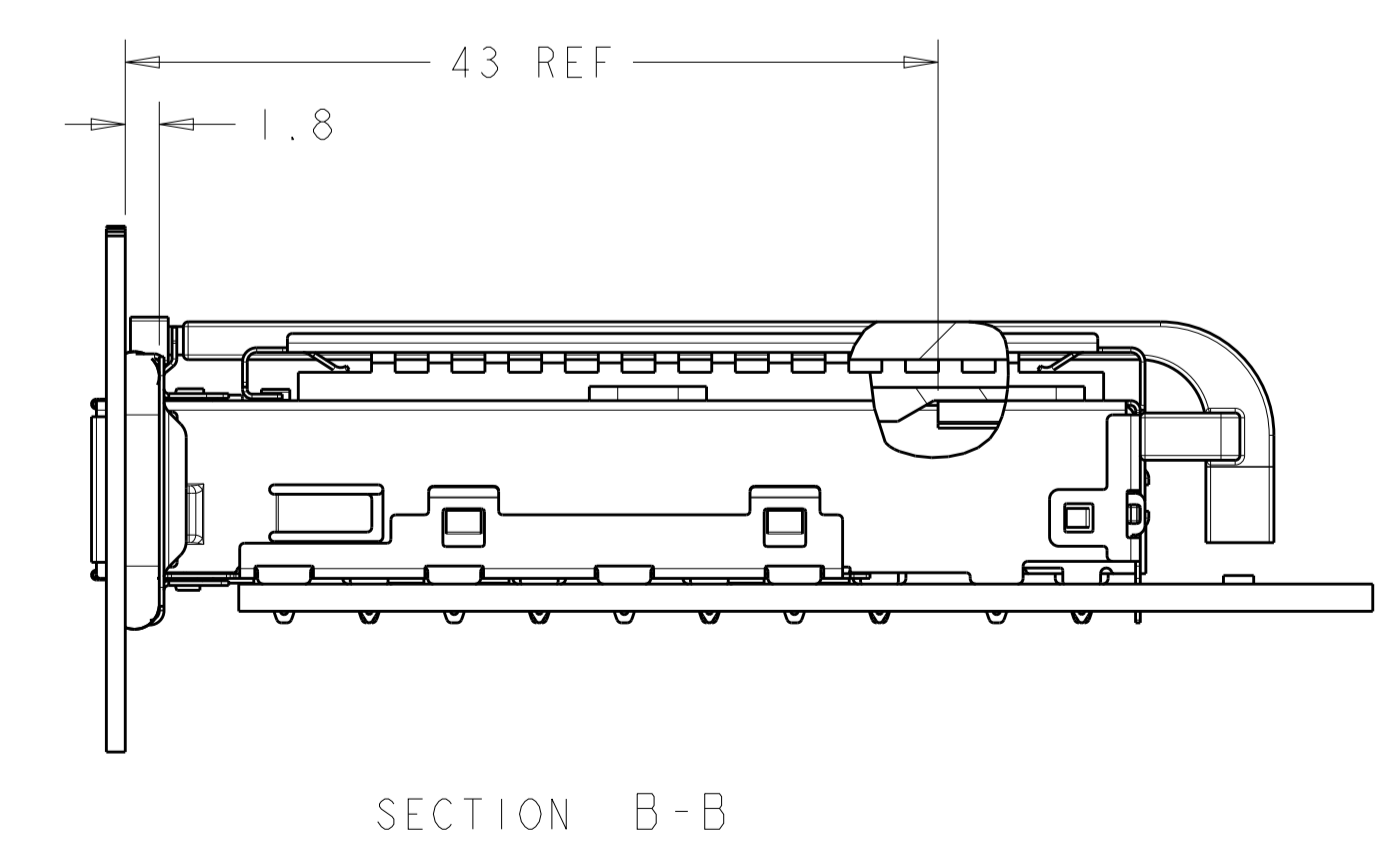
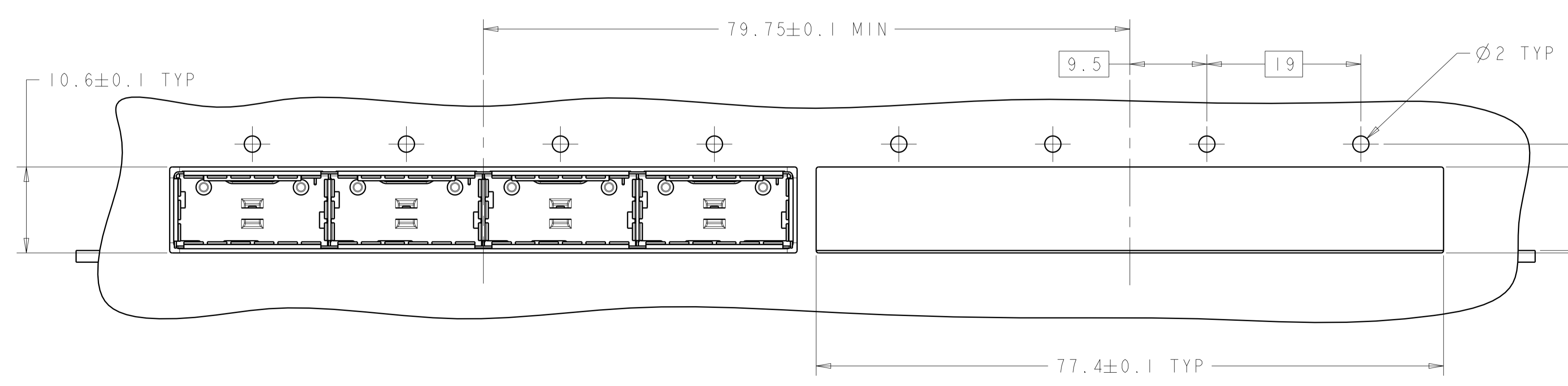

1-2170287-1  
ONE SIDED CONFIGURATION  
SCALE 5:2

THIS DRAWING IS A CONTROLLED DOCUMENT.		DMN: RINSEN SUN 29FEB2012	TE Connectivity
DIMENSIONS: mm		CHK: DENNY ZHU 29FEB2012	
TOLERANCES UNLESS OTHERWISE SPECIFIED:		APVD: ALEY CAI 29FEB2012	NAME: 1X4 CAGE ASSEMBLY, THRU BEZEL, W/ELASTOMERIC GASKET AND HEAT SINKS, QSFP
0 PLC ±	1 PLC ±0.35	PRODUCT SPEC: 108-2286	SIZE: 114-13217
2 PLC ±0.25	3 PLC ±	APPLICATION SPEC: 114-13217	WEIGHT: -
4 PLC ±	ANGLES ±	FINISH: -	CUSTOMER DRAWING
MATERIAL: -		A100779C=2170287 SCALE: 1:1 SHEET 2 OF 8 REV A	

LOC	DIST	REVISIONS			
P	LTN	DESCRIPTION	DATE	OWN	APVD
GP	00	SEE SHEET 1	-	-	-

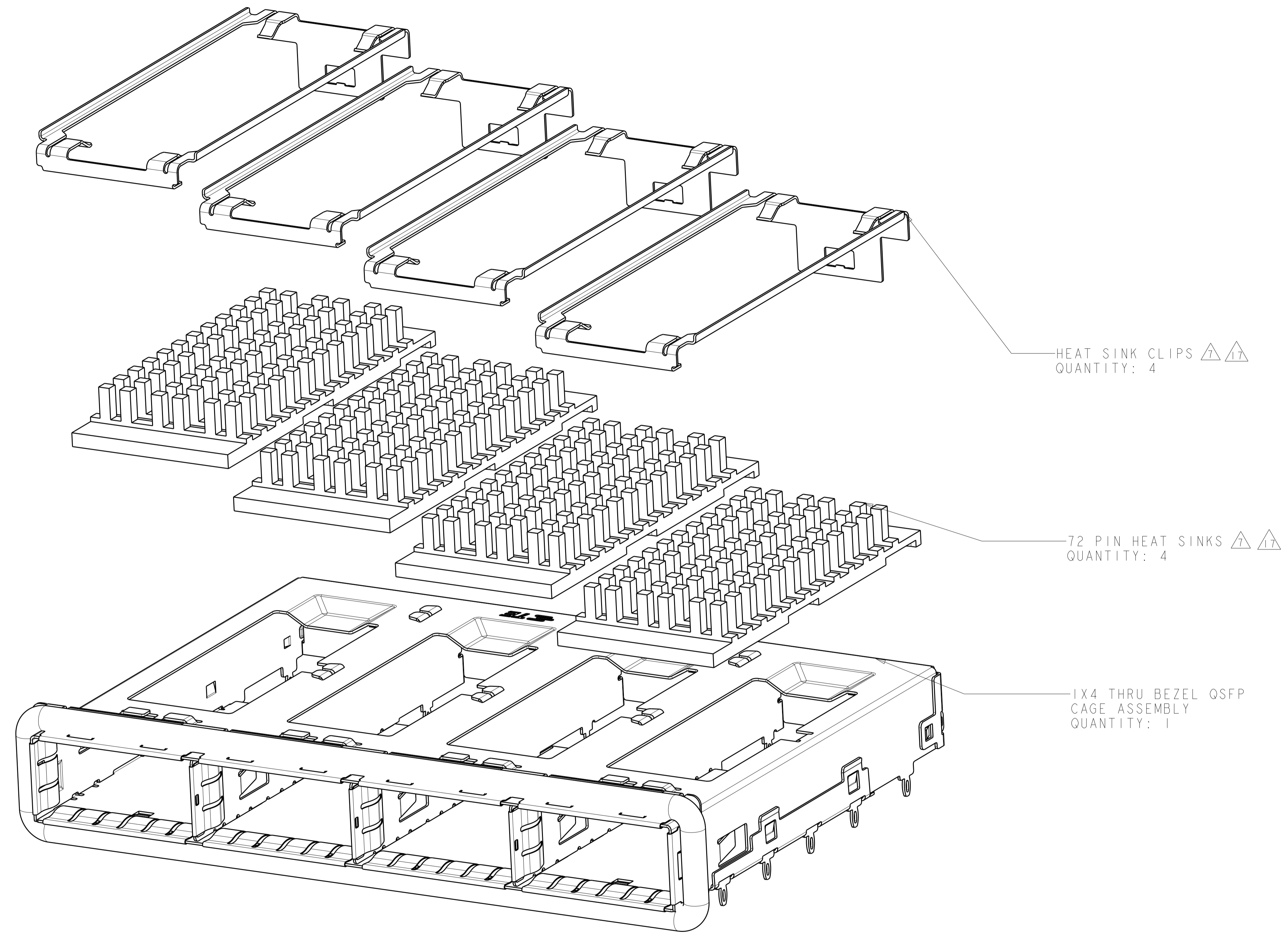

THIS DRAWING IS A CONTROLLED DOCUMENT.		OWN KINSEN SUN 29FEB2012	
DIMENSIONS: mm		CHK DENNY ZHU 29FEB2012	
		APVD ALEX CAI 29FEB2012	NAME 1X4 CAGE ASSEMBLY, THRU BEZEL, W/ELASTOMERIC GASKET AND HEAT SINKS, QSFP
TOLERANCES UNLESS OTHERWISE SPECIFIED:		PRODUCT SPEC 108-2286	RESTRICTED TO
0 PLC $\pm$		APPLICATION SPEC 114-13217	SIZE A100779C=2170287
1 PLC $\pm 0.35$		WEIGHT	SCALE 1:1
2 PLC $\pm 0.25$		CUSTOMER DRAWING	SHEET 3 OF 8
3 PLC $\pm$			REV A
4 PLC $\pm$			
ANGLES $\pm$			
FINISH			

LOC	DIST	REVISIONS					
GP	00	P	LTN	DESCRIPTION	DATE	DMN	APVD
-	-	-	-	SEE SHEET 1	-	-	-

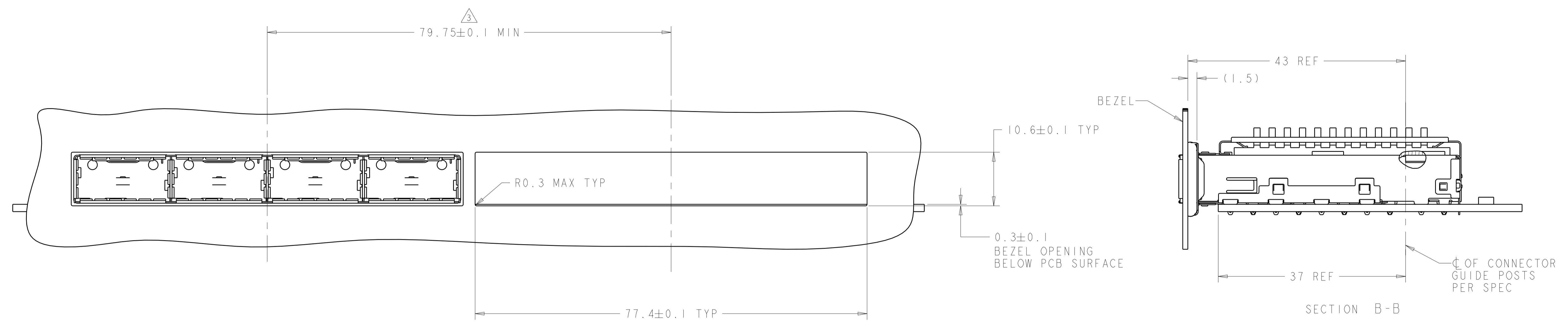

ONE SIDED CONFIGURATION  
 SCALE 5:2

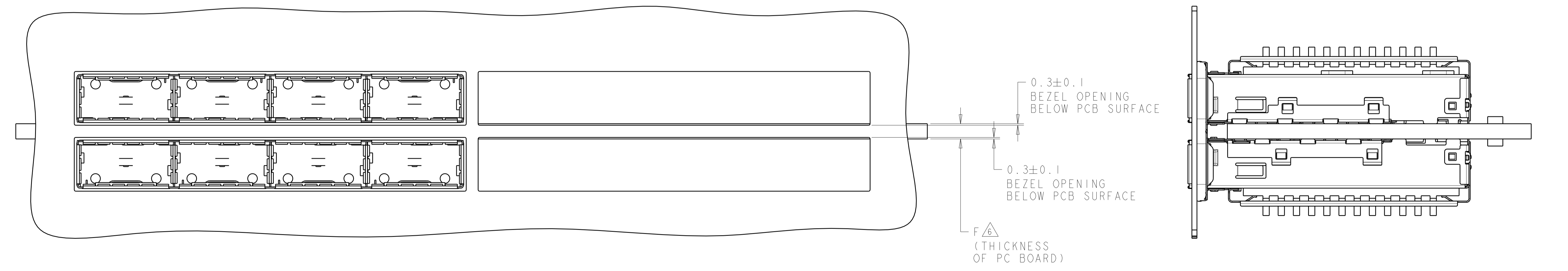

BELLY TO BELLY CONFIGURATION  
 SIMILAR TO ONE SIDED  
 EXCEPT WHERE NOTED  
 SCALE 5:2

THIS DRAWING IS A CONTROLLED DOCUMENT.		DMN RINSEN SUH 29FEB2012	TE Connectivity
DIMENSIONS:		CHK DENNY ZHU 29FEB2012	
mm	TOLERANCES UNLESS OTHERWISE SPECIFIED:	APVD ALEX CAI 29FEB2012	NAME 1X4 CAGE ASSEMBLY, THRU BEZEL, W/ELASTOMERIC GASKET AND HEAT SINKS, QSFP
	0 PLC ± 1 PLC ±0.35 2 PLC ±0.25 3 PLC ± 4 PLC ± ANGLES ± FINISH ±	PRODUCT SPEC 108-2286	SIZE A100779C=2170287
MATERIAL		APPLICATION SPEC 114-13217	RESTRICTED TO
		WEIGHT	SCALE 1:1 SHEET 4 OF 8 REV A
		CUSTOMER DRAWING	

LOC	DIST	REV	DATE	BY	APPV
GP	00				

REVISIONS			
NO.	DESCRIPTION	DATE	BY
1	SEE SHEET 1		

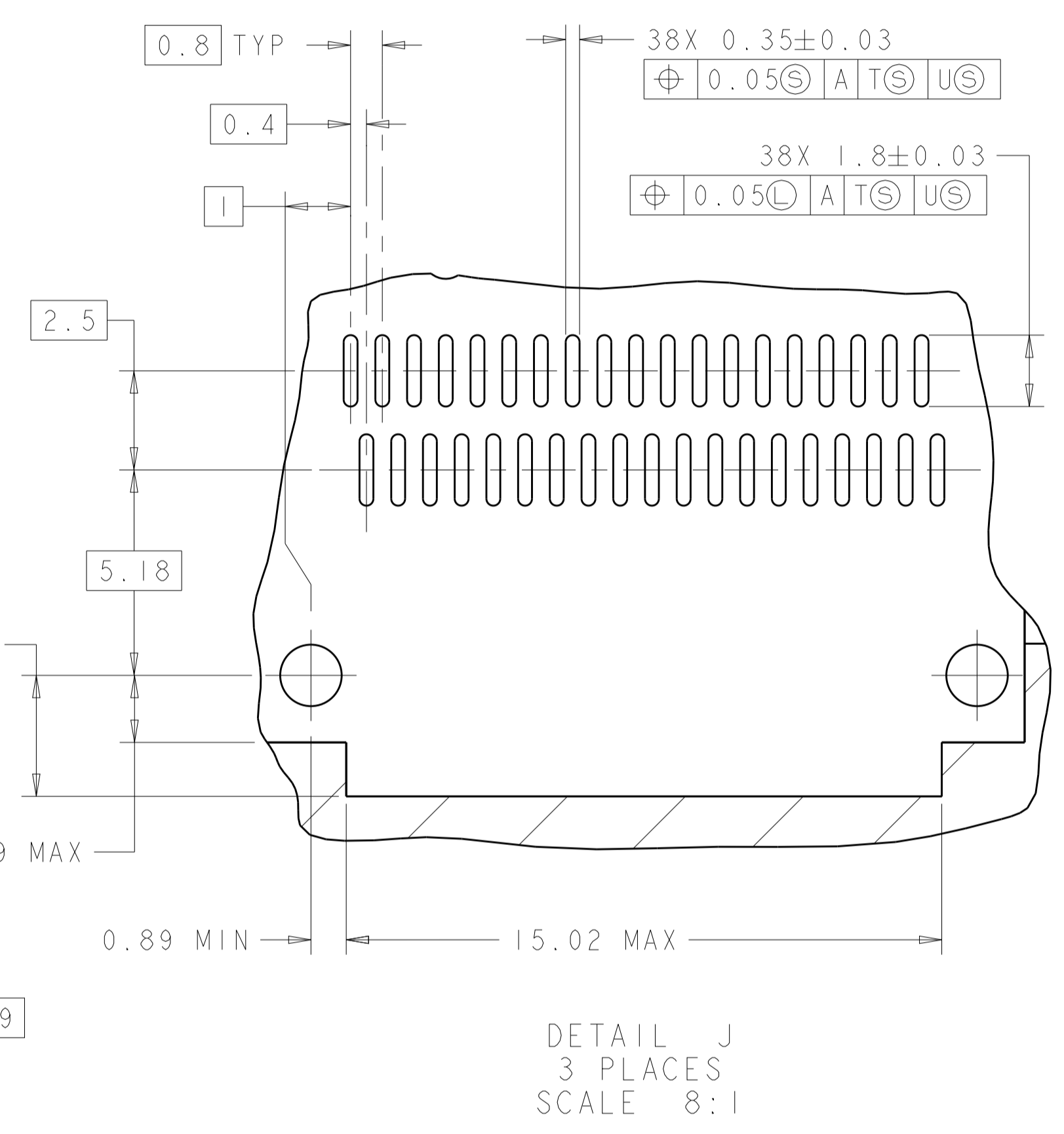
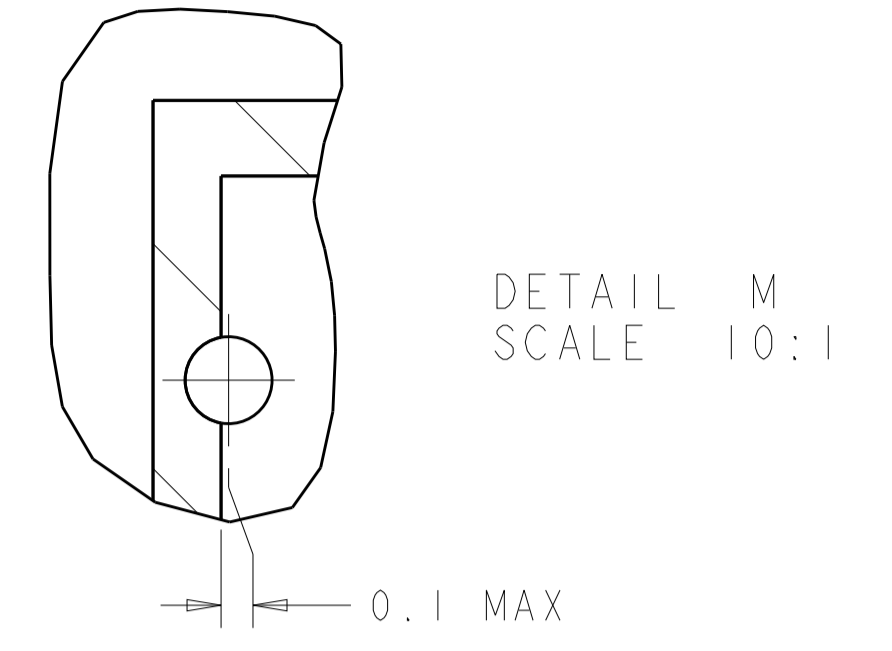
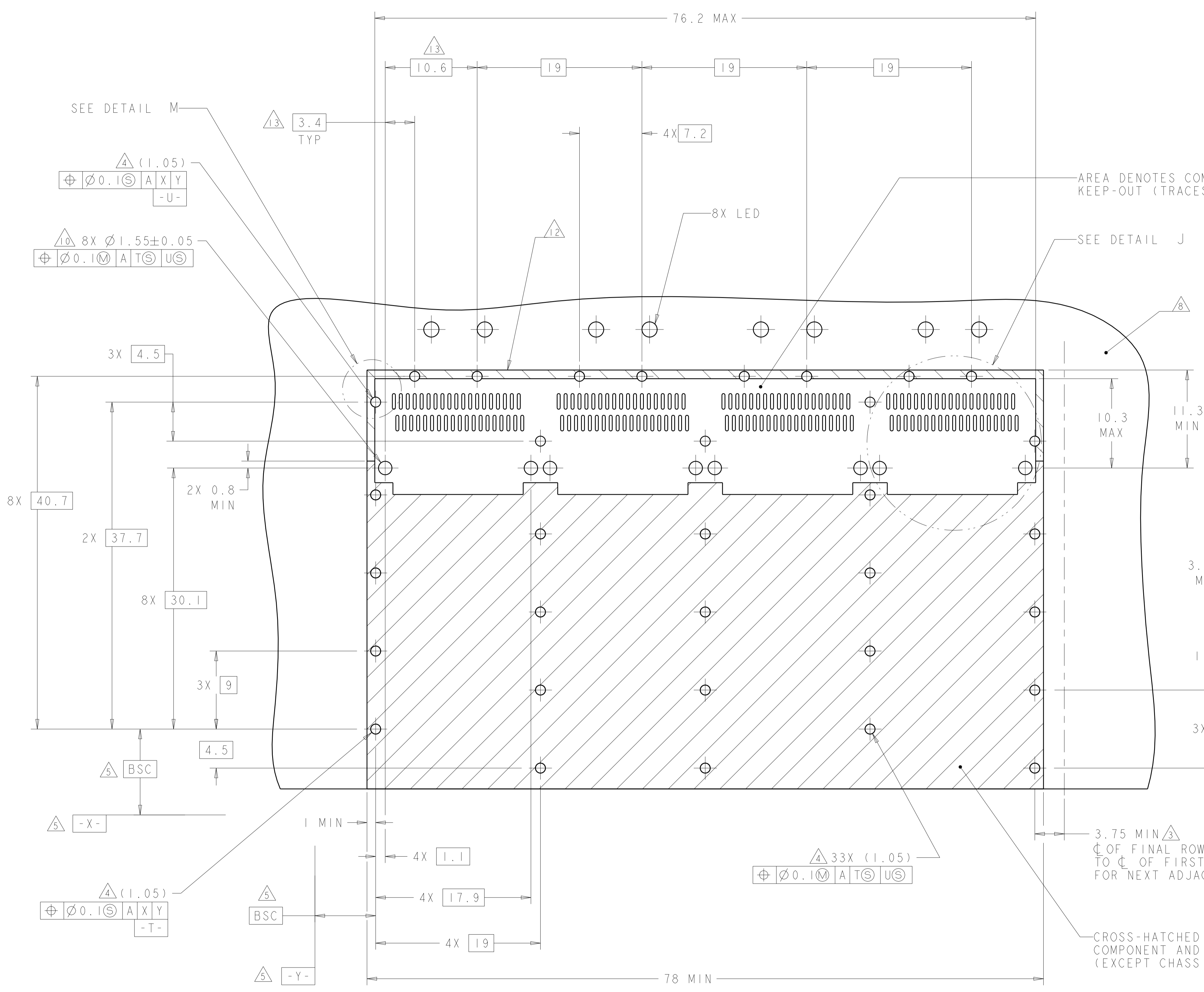

RECOMMENDED PC BOARD LAYOUT  
 SINGLE SIDE MOUNT CONFIGURATION  
 SCALE 4:1

3.75 MIN  $\Delta$ 3  
 C OF FINAL ROW OF HOLES  
 TO C OF FIRST ROW OF HOLES  
 FOR NEXT ADJACENT CAGE

CROSS-HATCHED AREA DENOTES  
 COMPONENT AND TRACE KEEP-OUT  
 (EXCEPT CHASSIS GROUND)

THIS DRAWING IS A CONTROLLED DOCUMENT.		OWN: RINSEN SUN 29FEB2012	TE Connectivity
DIMENSIONS: mm		CHK: DENNY ZHU 29FEB2012	
TOLERANCES UNLESS OTHERWISE SPECIFIED:		APVD: ALEY CAI 29FEB2012	NAME: 1X4 CAGE ASSEMBLY, THRU BEZEL, W/ELASTOMERIC GASKET AND HEAT SINKS, QSFP
0 PLC	±	PRODUCT SPEC	108-2286
1 PLC	±0.35	APPLICATION SPEC	114-13217
2 PLC	±0.25	WEIGHT	
3 PLC	±	CUSTOMER DRAWING	
4 PLC	±	SCALE	1:1
ANGLES	±	SHEET	5 OF 8
MATERIAL		REV	A

LOC	DIST	REV	DATE	BY	APPV
GP	00				

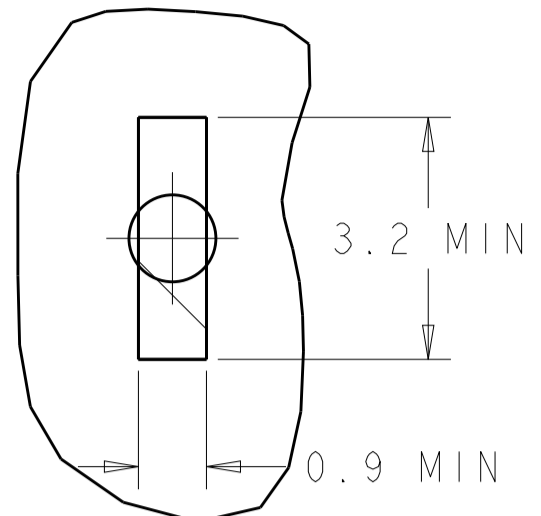

DETAIL M  
SCALE 10:1

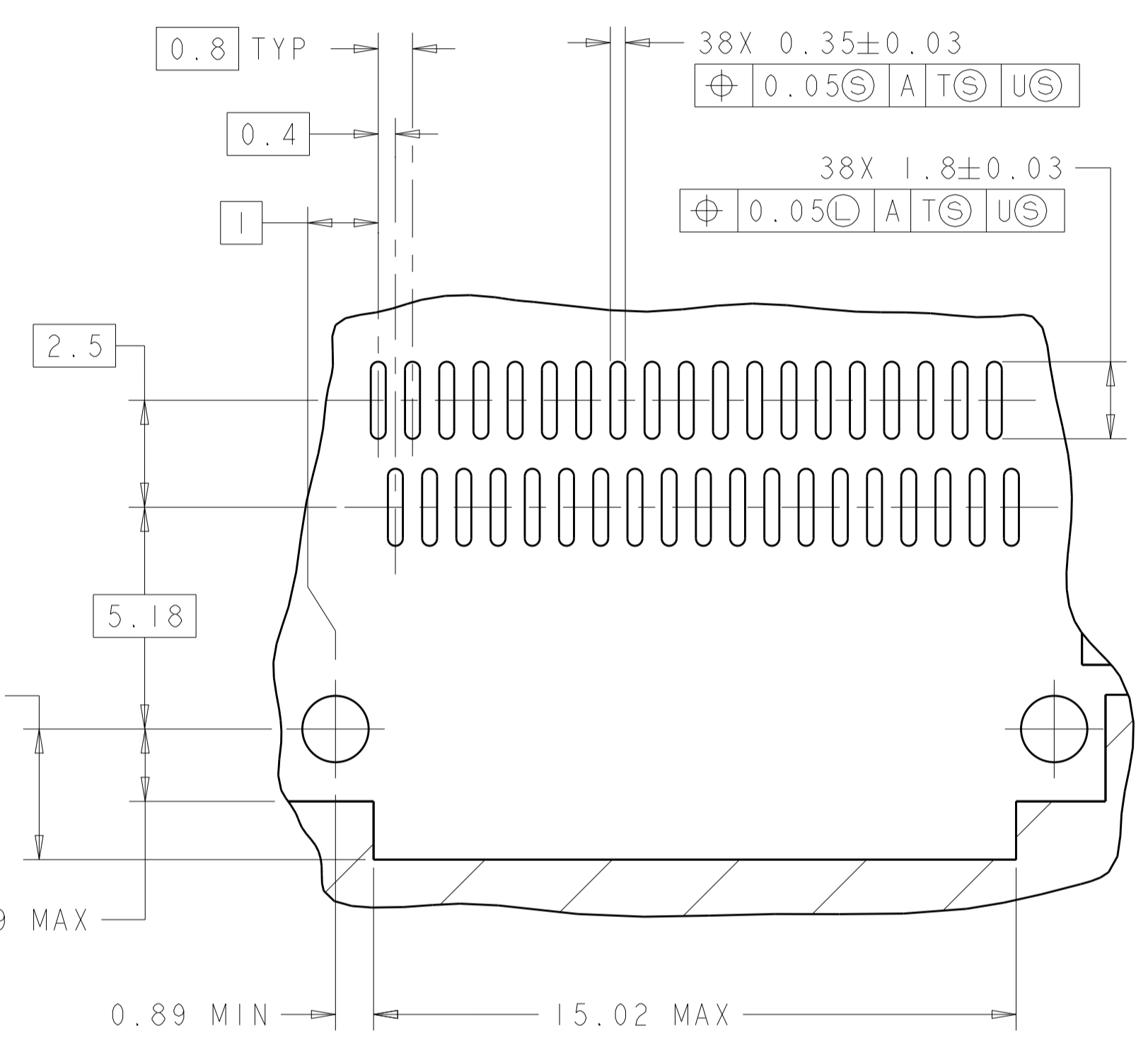
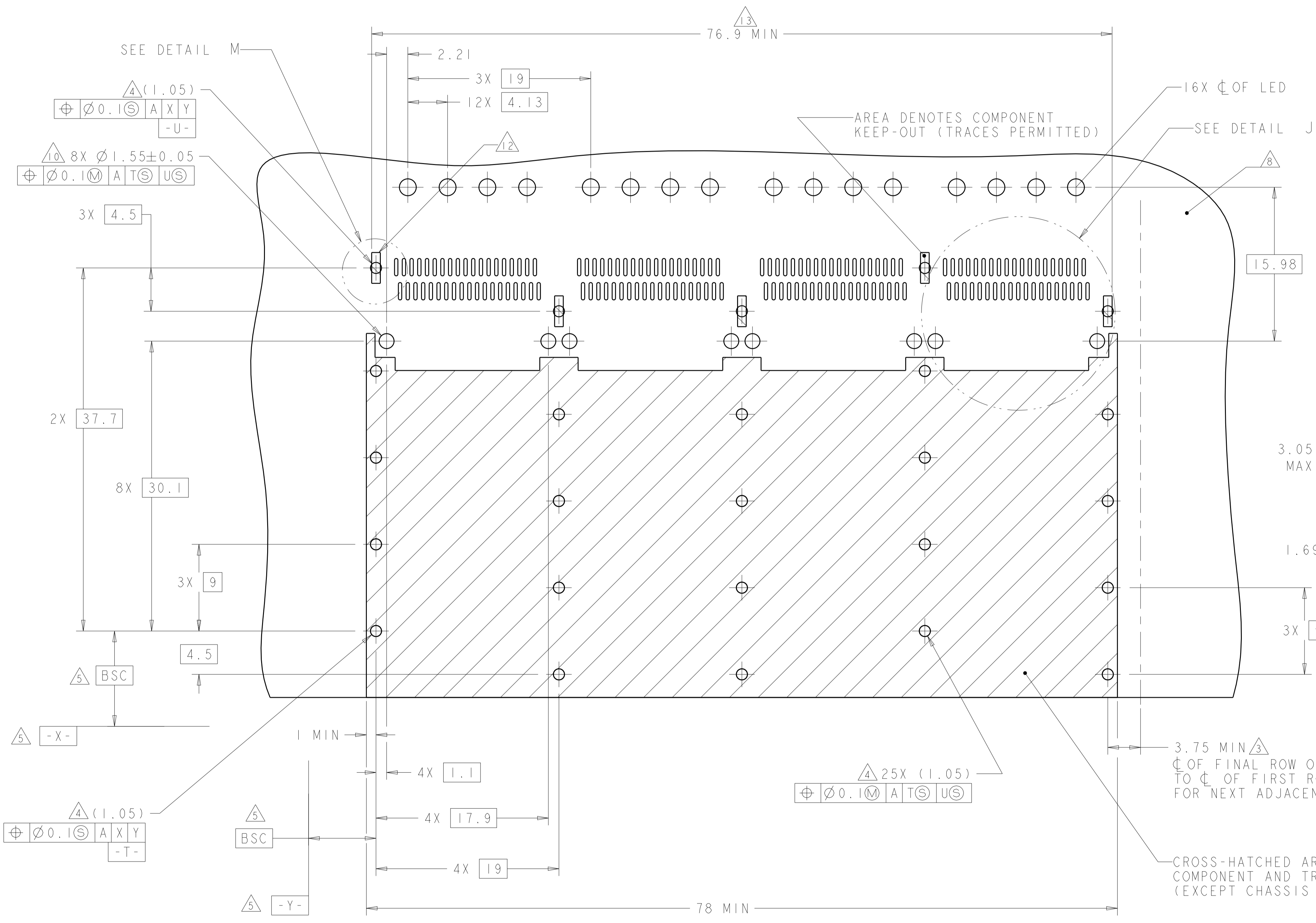

DETAIL J  
3 PLACES  
SCALE 8:1

RECOMMENDED PC BOARD LAYOUT FOR 1-2170287-0  
 SINGLE SIDE MOUNT CONFIGURATION  
 SCALE 4:1

THIS PRODUCT HAS NOT COMPLETED VALIDATION/QUALIFICATION TESTING

THIS DRAWING IS A CONTROLLED DOCUMENT.		OWN: KINSEN SUN 29FEB2012	TE Connectivity
DIMENSIONS: mm		CHK: DENNY ZHU 29FEB2012	
TOLERANCES UNLESS OTHERWISE SPECIFIED:		APVD: AILEY CAI 29FEB2012	NAME: 1X4 CAGE ASSEMBLY, THRU BEZEL, W/ELASTOMERIC GASKET AND HEAT SINKS, QSFP
0 PLC	±	PRODUCT SPEC	SIZE: CAGE CODE DRAWING NO
1 PLC	±0.35	108-2286	RESTRICTED TO
2 PLC	±0.25	APPLICATION SPEC	A100779C=2170287
3 PLC	±	114-13217	SCALE 1:1 SHEET 6 OF 8 REV A
4 PLC	±	WEIGHT	
ANGLES	±	CUSTOMER DRAWING	
MATERIAL	FINISH		



LOC	DIST	REVISIONS					
GP	00	P	LTN	DESCRIPTION	DATE	DMN	APVD
		-		SEE SHEET 1			

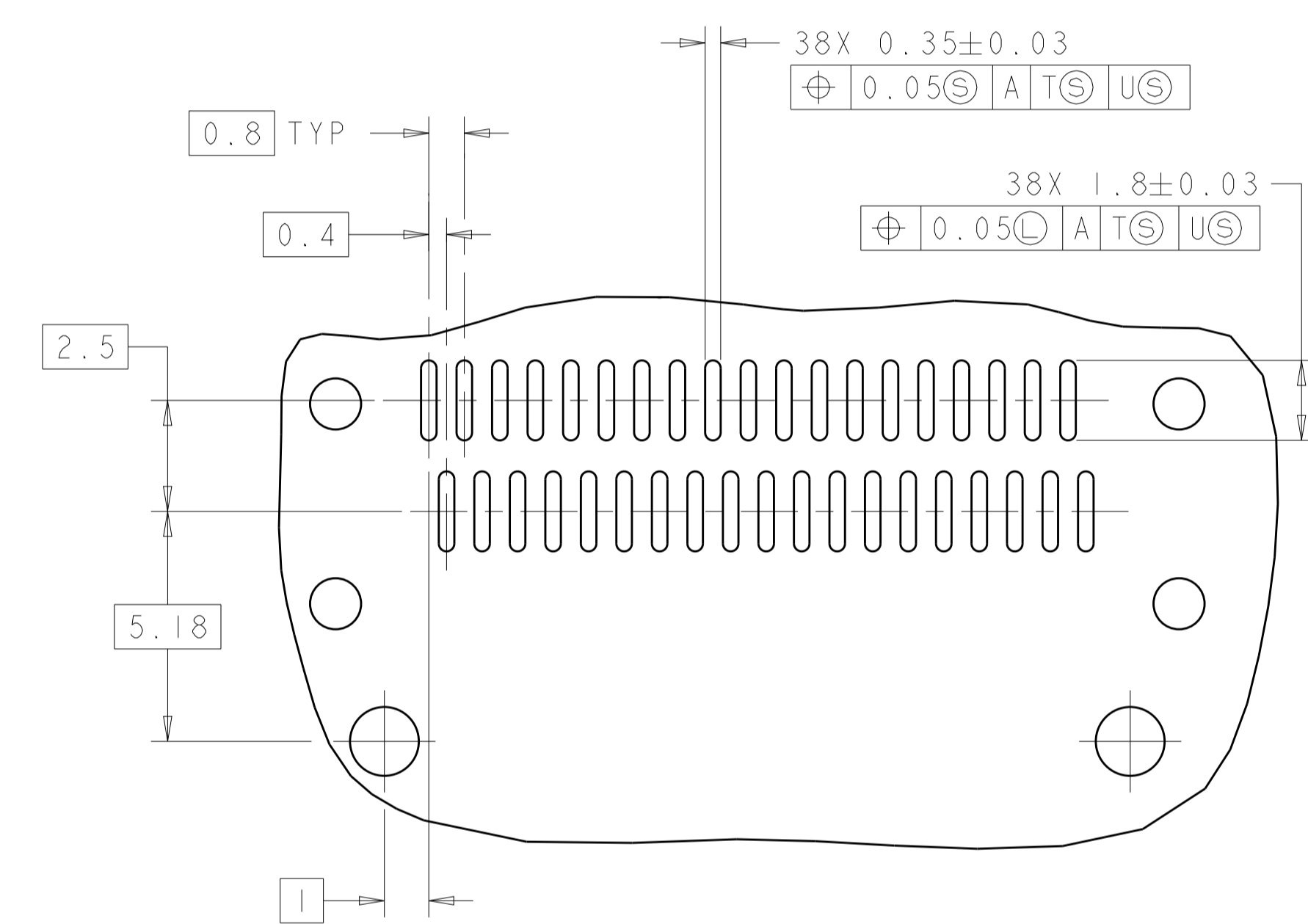
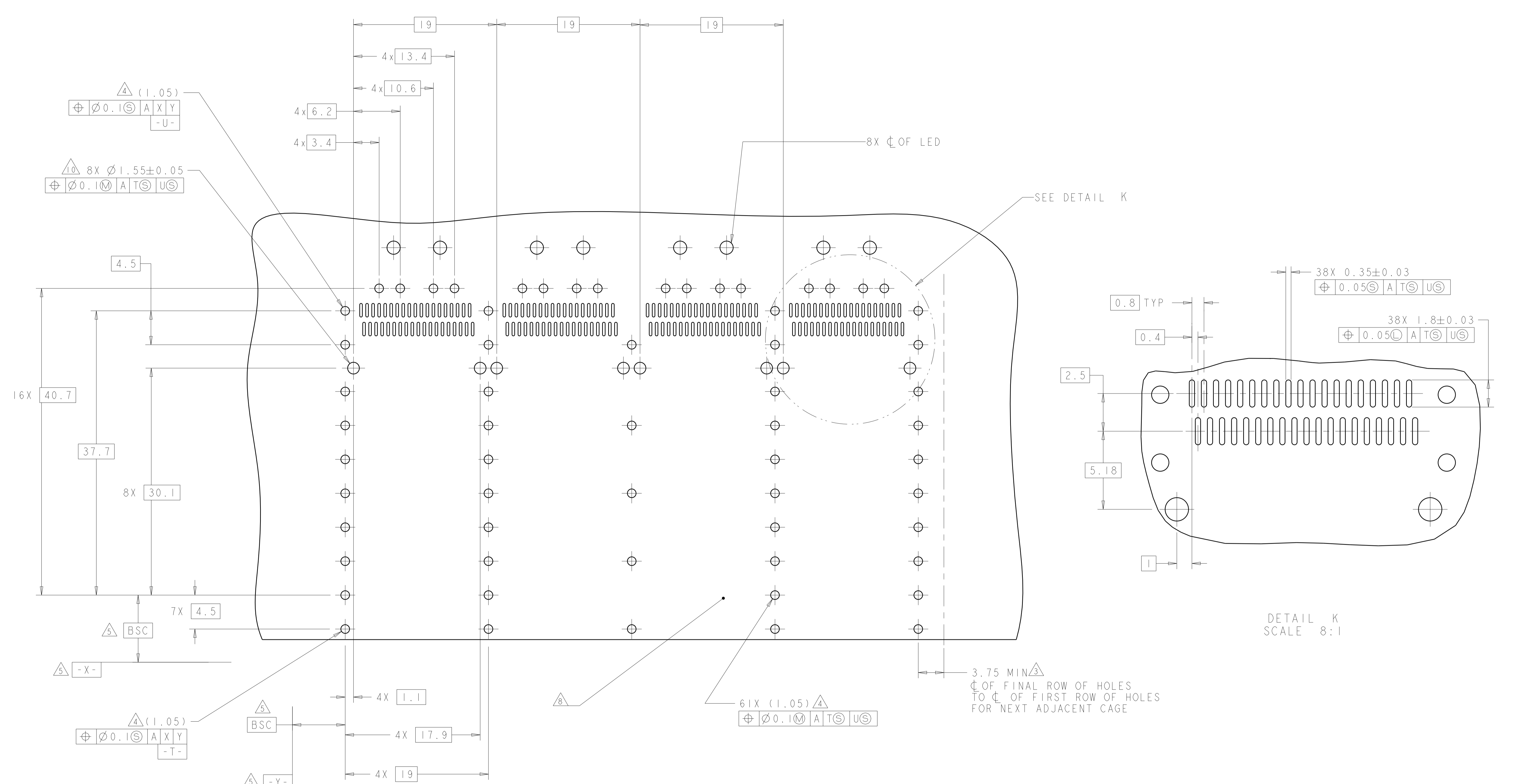

DETAIL K  
SCALE 8:1

RECOMMENDED PC BOARD LAYOUT  
 BELLY TO BELLY CONFIGURATION  
 SEE SHEET 4 FOR COMPONENT AND TRACE KEEP-OUTS  
 SCALE 4:1

THIS PRODUCT HAS NOT COMPLETED VALIDATION/QUALIFICATION TESTING

THIS DRAWING IS A CONTROLLED DOCUMENT.		DMN: KINSEN SUN 29FEB2012	TE Connectivity
DIMENSIONS: mm		CHK: DENNY ZHU 29FEB2012	
TOLERANCES UNLESS OTHERWISE SPECIFIED:		APVD: ALEY CAI 29FEB2012	NAME: 1X4 CAGE ASSEMBLY, THRU BEZEL, W/ELASTOMERIC GASKET AND HEAT SINKS, QSFP
0 PLC	±	PRODUCT SPEC	SIZE: CAGE CODE DRAWING NO
1 PLC	±0.35	108-2286	RESTRICTED TO
2 PLC	±0.25	APPLICATION SPEC	A100779C=2170287
3 PLC	±	114-13217	SCALE 1:1 SHEET 8 OF 8 REV A
4 PLC	±	WEIGHT	
ANGLES	±	CUSTOMER DRAWING	
MATERIAL			
FINISH			



## X-ON Electronics

Largest Supplier of Electrical and Electronic Components

*Click to view similar products for [I/O Connectors](#) category:*

*Click to view products by [TE Connectivity](#) manufacturer:*

Other Similar products are found below :

[571763P](#) [58098-0628](#) [72.250.1628.2](#) [72.250.2428.2](#) [74720-0505](#) [76.350.0729.0](#) [76871-1403](#) [FCN-244F080-G/1](#) [FCN-260A9920](#) [PCR-E36PM](#) [PCS-XE26MA+](#) [G38A71314B](#) [DX40-50P\(55\)](#) [1571250010](#) [157-22500-3](#) [MS3471L14-19P L/C](#) [91-569786-35H](#) [172501-4002](#) [172501-6002](#) [FCN-260C008-A/L0](#) [FCN-260C024-AL0](#) [FCN-261Z008](#) [2000314-1](#) [200331-1](#) [PCR-E36FC+](#) [PCS-E28FS+](#) [PCS-XE26SLFD+](#) [PCS-XE26SLFDT+](#) [G730VID08BDC24](#) [U90B2054081210](#) [UE86K842720321](#) [38113800006](#) [DP3AR020WQ1R200](#) [Z4.102.0680.0](#) [500-1040](#) [500-1052](#) [500-1054](#) [ZP-4008-66L](#) [0709821002](#) [10-565995-597N](#) [DX40-20P\(55\)](#) [5554841-1](#) [MS3474W18-8P-LC\\*](#) [U90B3054061110](#) [U65-E04-4020](#) [ZPF000000000097891](#) [557-262M2-06C](#) [747360449](#) [10099439-003C-TRLF](#) [10137239-0021LF](#)