

LOC	DIST	REV	DESCRIPTION	DATE	OWN	APVD
GP	00	A	RELEASE PER ECO-16-002978	3MAR2016	RG	SH

- ⚠ CAGE ASSEMBLY MATERIAL: NICKEL SILVER, 0.25 THICK
 HEAT SINK MATERIAL: ALUMINUM
 HEAT SINK CLIP MATERIAL: STAINLESS STEEL
 EMI SPRING MATERIAL: COPPER ALLOY
 EMI GASKET MATERIAL: CONDUCTIVE RUBBER, UL 94V-0 RATED
 EMI GASKET PLATE MATERIAL: STAINLESS STEEL
- ② PITCH BETWEEN PORTS OF ONE 1X4 CAGE ASSEMBLY.
- ③ SPACING BETWEEN CAGES ON THE SAME PC BOARD, TO BE SPECIFIED BY CUSTOMER, MUST COMPLY WITH MINIMUM DIMENSIONS SHOWN.
- ④ REFERENCE APPLICATION SPEC 114-13217 FOR RECOMMENDED DRILL HOLE DIAMETER AND PLATING THICKNESS.
- ⑤ DATUMS AND BASIC DIMENSIONS ESTABLISHED BY CUSTOMER.
- ⑥ DIMENSION F IS THE NOMINAL THICKNESS OF CUSTOMER SUPPLIED PC BOARD,
 SINGLE SIDED PC BOARD MINIMUM THICKNESS = 1.45mm
 DOUBLE SIDED PC BOARD MINIMUM THICKNESS = 5.0mm PER CUSTOM.
- ⑦ HEAT SINKS, LIGHT PIPES, AND HEAT SINK CLIPS SHIPPED ASSEMBLED TO CAGE ASSEMBLY. CAGE ASSEMBLY MAY BE PRESSED INTO THE PCB AS SHIPPED.
- ⑧ DATUM -A- IS TOP SURFACE OF PC BOARD.
- ⑨ DIMENSION APPLIES WITH MODULE INSERTED IN CAGE.
- ⑩ UNPLATED THRU HOLE.

- 11. MATES WITH QSFP MSA COMPATIBLE TRANSCEIVER.
- ⚠ SURFACE TRACES PERMITTED WITHIN THIS AREA EXCEPT WHERE CAGE STANDOFFS, SHOWN IN DETAIL A, CONTACT PC BOARD.
- ⚠ BASELINE FOR THESE DIMENSIONS IS THE CENTER OF COMPLIANT PIN HOLE.
- ⚠ DATE CODE (YYWWD) MARKED ON TOP OF CAGE AND CONCEALED BY HEAT SINKS APPLIES TO CAGE ASSEMBLY ONLY.
- ⑬ REFERENCE APP SPEC 114-13217 FOR GASKET THICKNESS CALCULATION.
- ⑭ EMI SPRING FINISH: TIN PLATING OVER NICKEL
 HEAT SINK FINISH: ANODIZED OR NICKEL PLATING.

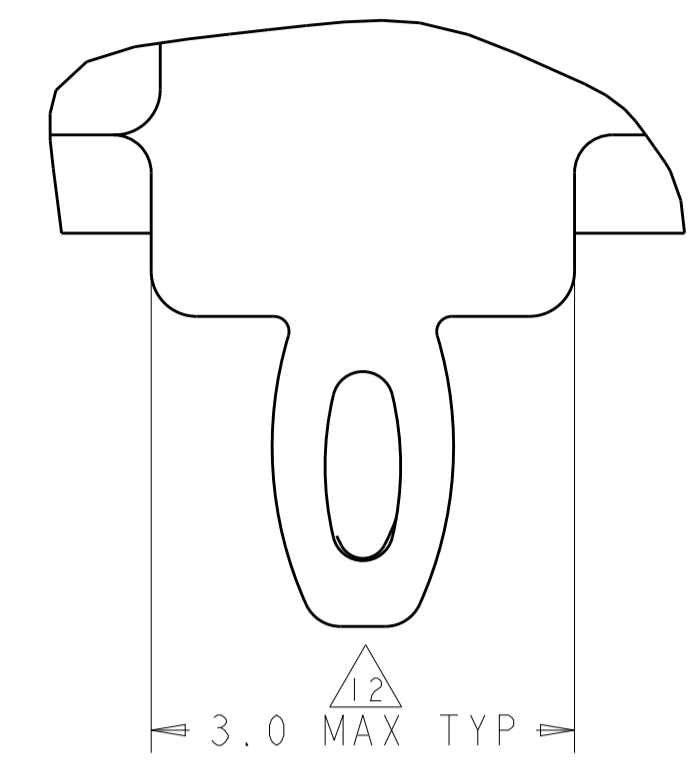

DETAIL A
SCALE 20:1

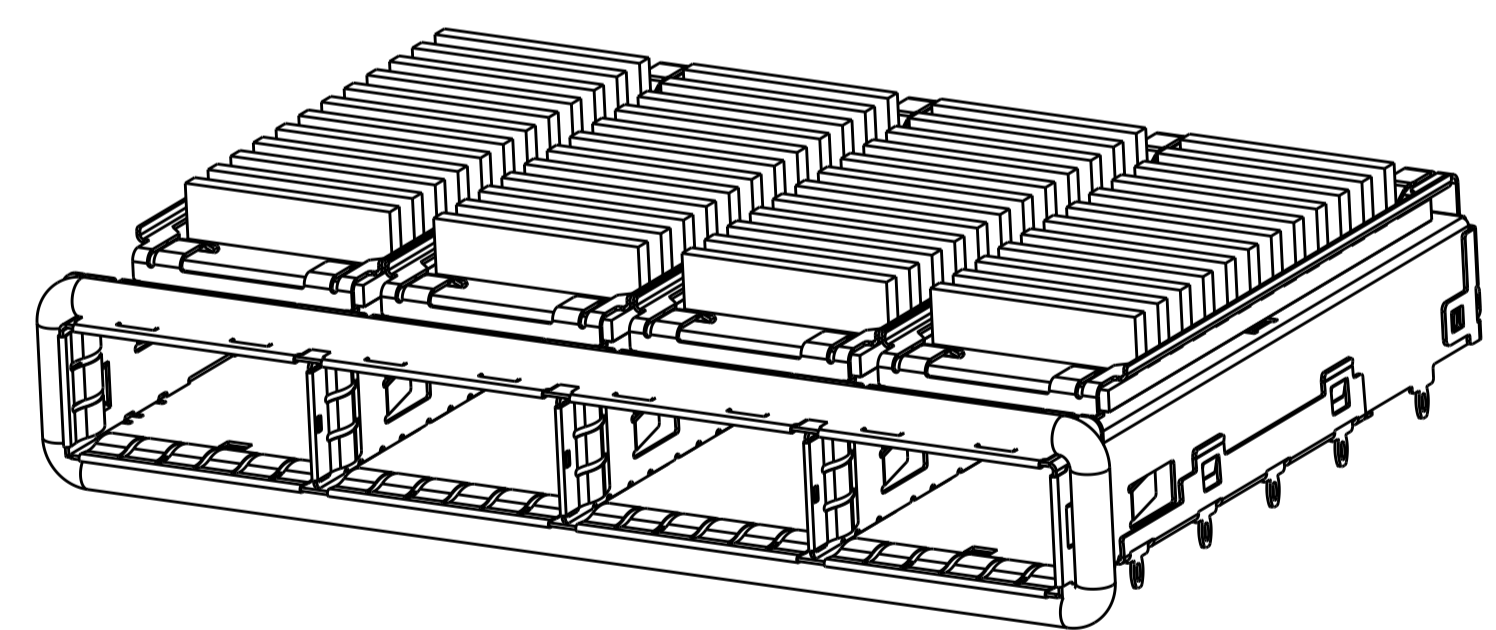
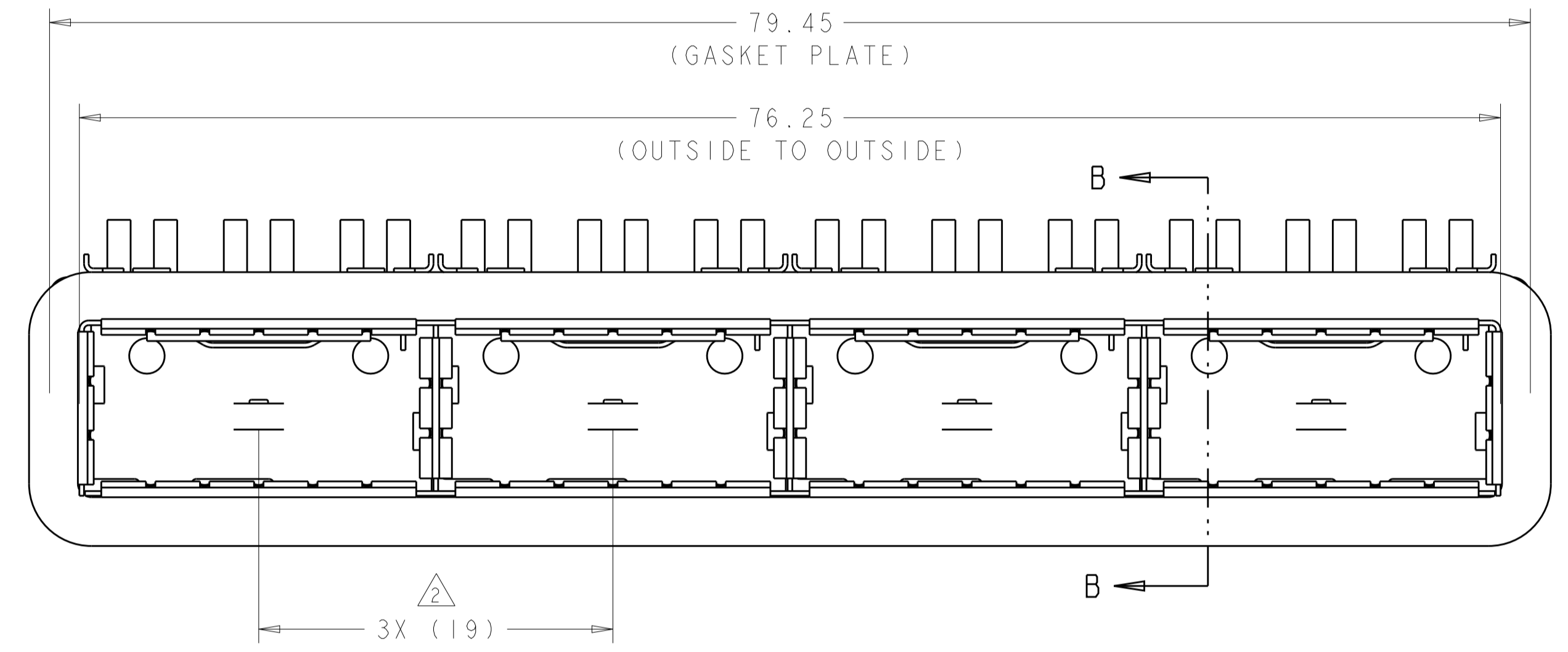
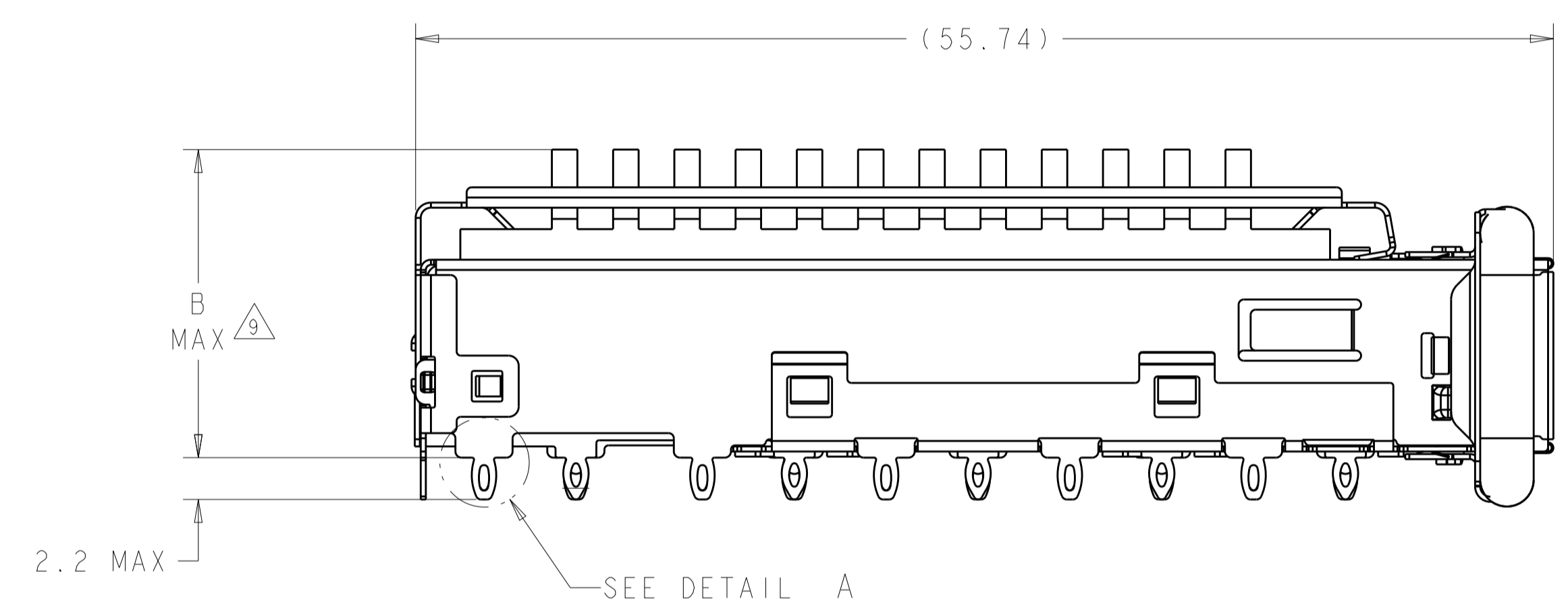

2170287-4, 2170287-5, 2170287-6
SCALE 2:1

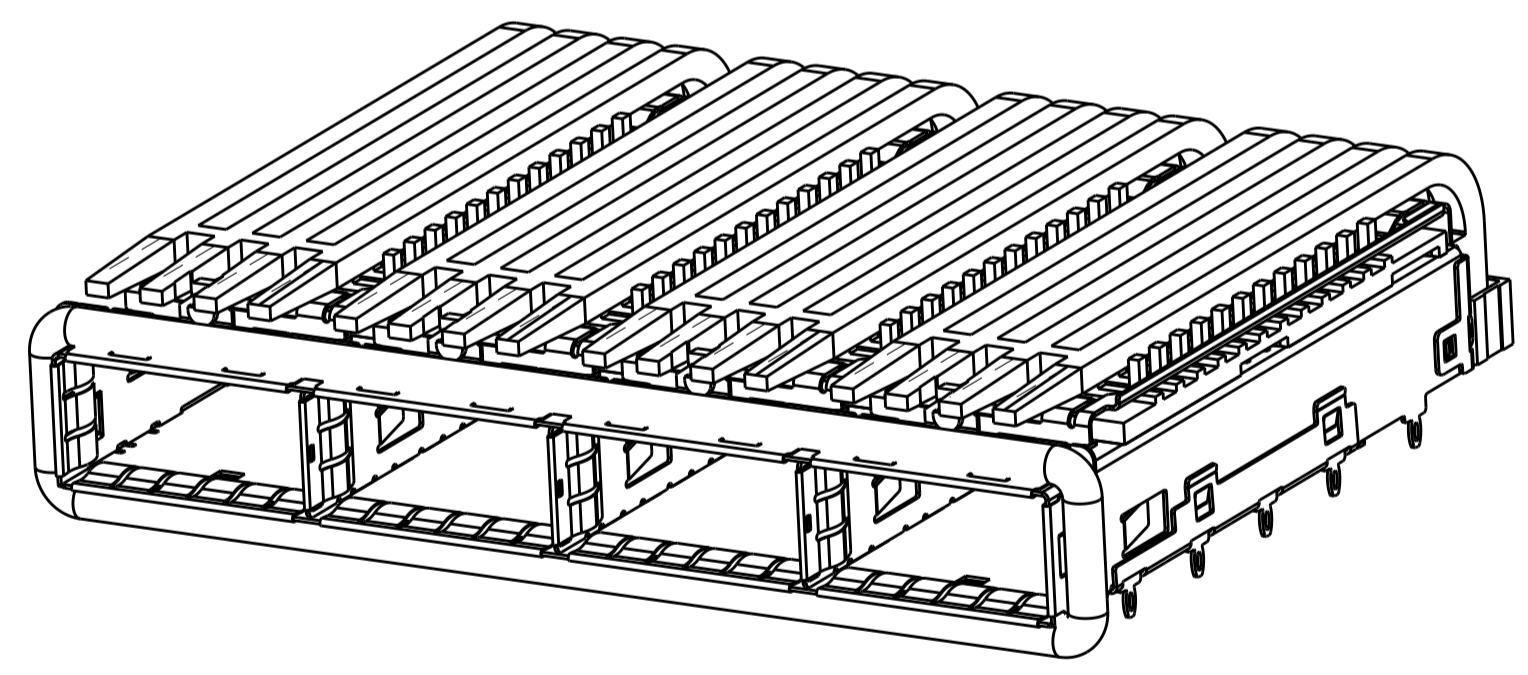

1-2170287-0
SCALE 2:1

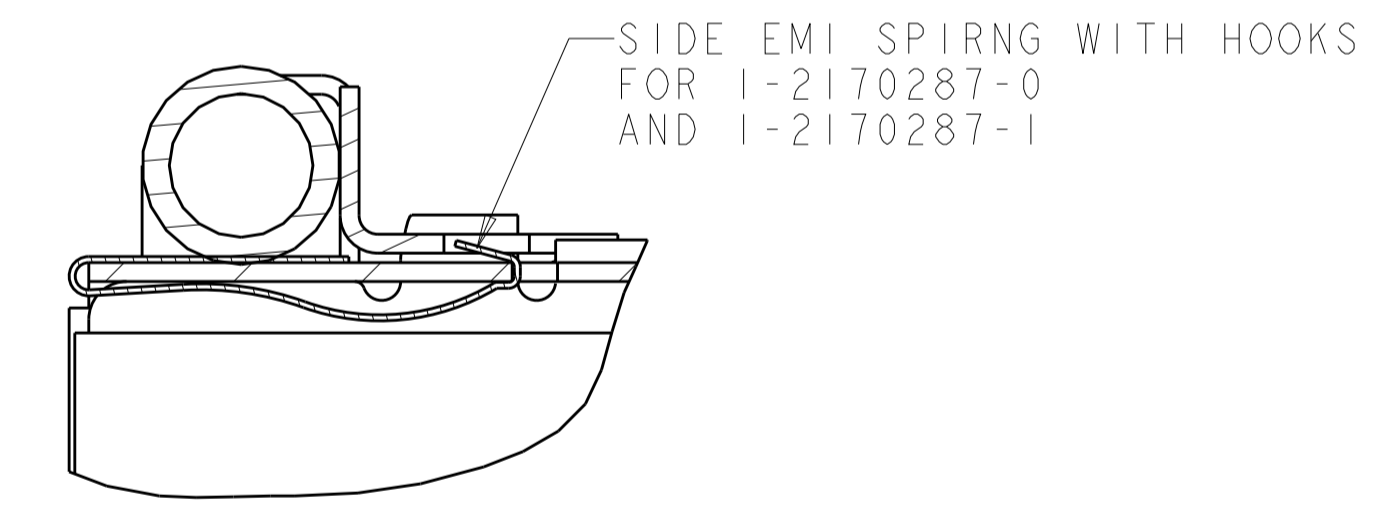

SECTION B-B
SCALE 10:1

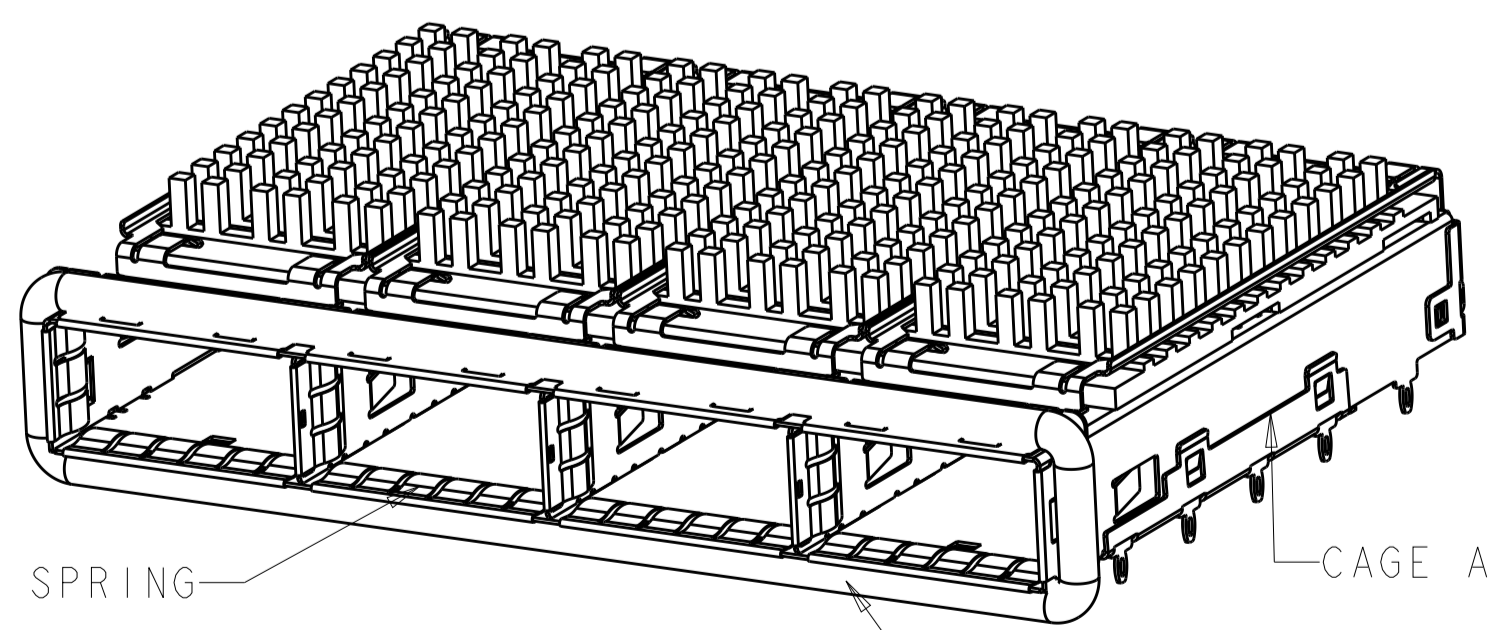

2170287-1, 2170287-2, 2170287-3
SCALE 2:1

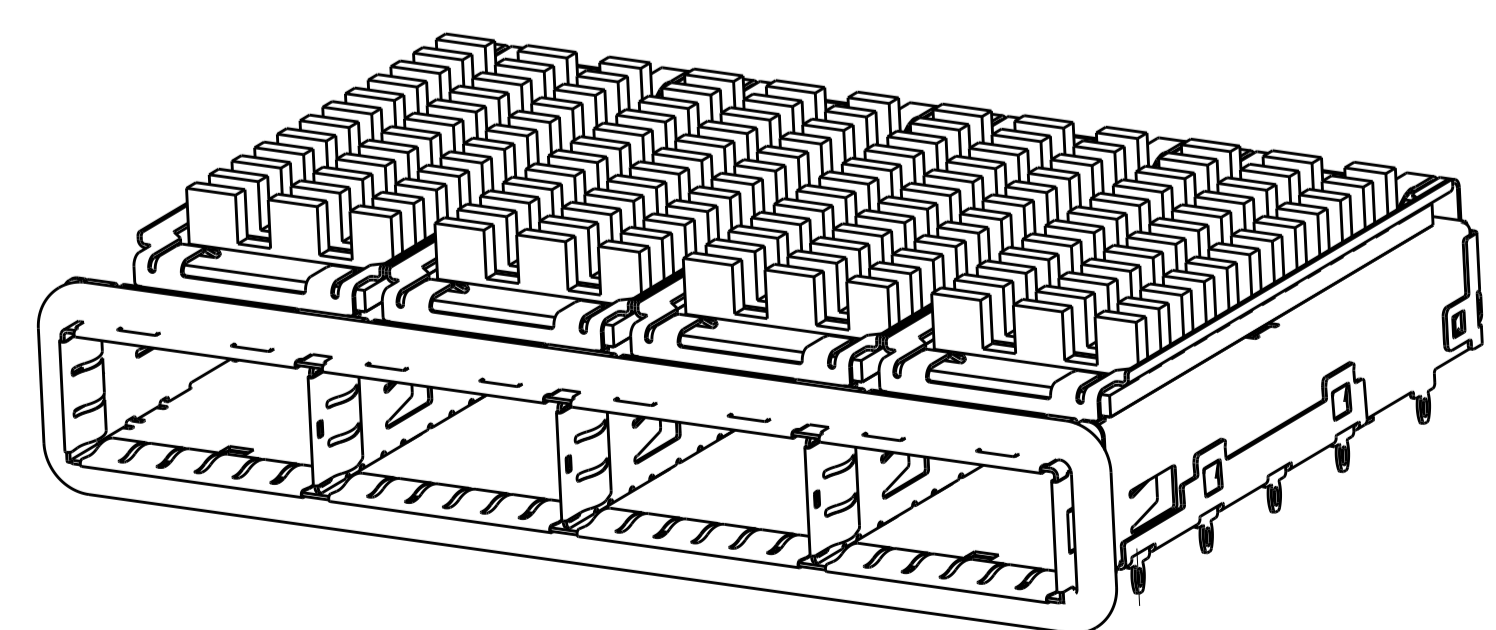

2170287-7, 2170287-8, 2170287-9
SCALE 2:1

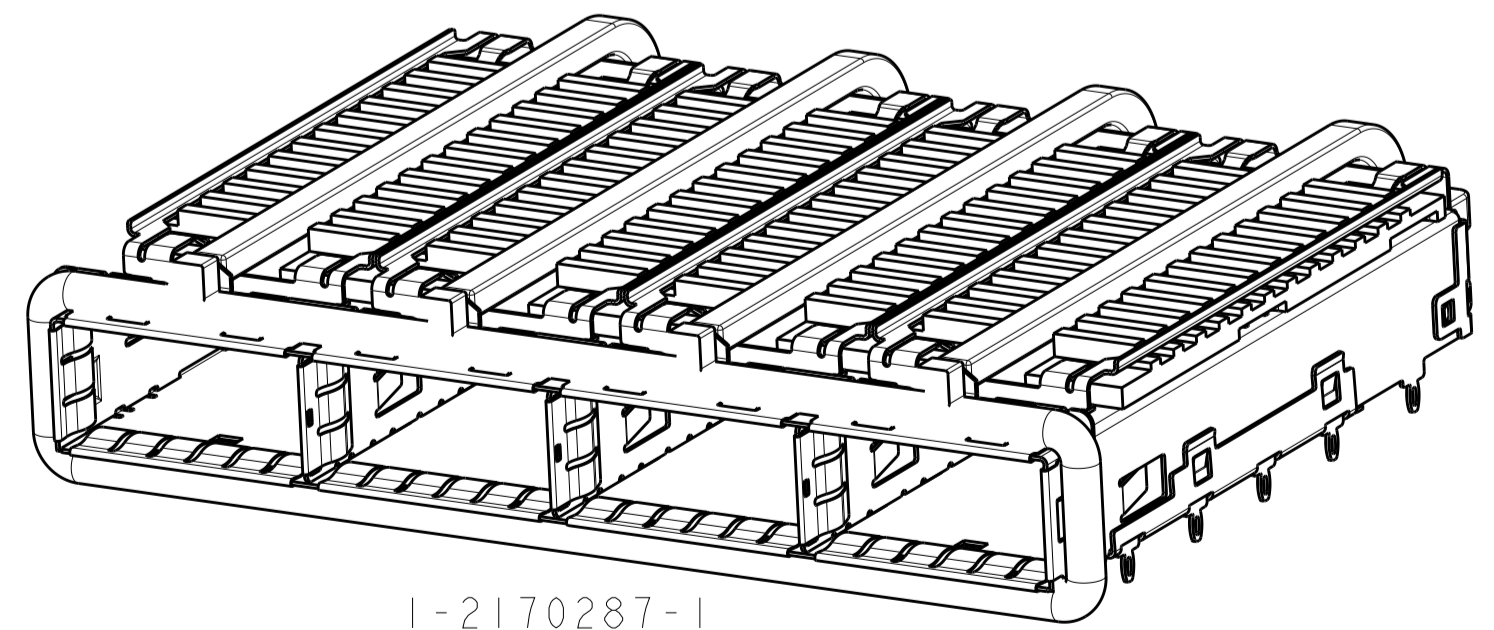

1-2170287-1
SCALE 2:1

13.7	PCI(FIN TYPE)	1-2170287-1
15.0	CUSTOMIZED HEAT SINK	1-2170287-0
23.0	NETWORKING(FIN TYPE)	2170287-9
16.0	SAN(FIN TYPE)	2170287-8
13.7	PCI(FIN TYPE)	2170287-7
23.0	NETWORKING(FIN TYPE)	2170287-6
16.0	SAN(FIN TYPE)	2170287-5
13.7	PCI(FIN TYPE)	2170287-4
23.0	NETWORKING(PIN TYPE)	2170287-3
16.0	SAN(PIN TYPE)	2170287-2
13.7	PCI(PIN TYPE)	2170287-1
B	HEAT SINK PROFILE	PART NUMBER

THIS DRAWING IS A CONTROLLED DOCUMENT.

DIMENSIONS:	TOLERANCES UNLESS OTHERWISE SPECIFIED:	OWN: RINSEN SUN 29FEB2012	CHK: DENNY ZHU 29FEB2012	APVD: ALEY CAI 29FEB2012	NAME: 1X4 CAGE ASSEMBLY, THRU BEZEL, W/ELASTOMERIC GASKET AND HEAT SINKS, QSFP
mm	0 PLC ±0.35 1 PLC ±0.25 2 PLC ±0.25 3 PLC ±0.25 4 PLC ±0.25 ANGLES ±0.25	PRODUCT SPEC: 108-2286	APPLICATION SPEC: 114-13217	SIZE: CAGE CODE DRAWING NO: A100779C=2170287	RESTRICTED TO: -
MATERIAL:	FINISH:	WEIGHT:	CUSTOMER DRAWING	SCALE: 4:1	SHEET 1 OF 8 REV A

LOC	DIST	REVISIONS					
GP	00	P	LTN	DESCRIPTION	DATE	DMN	APVD
-	-	-	-	SEE SHEET 1	-	-	-

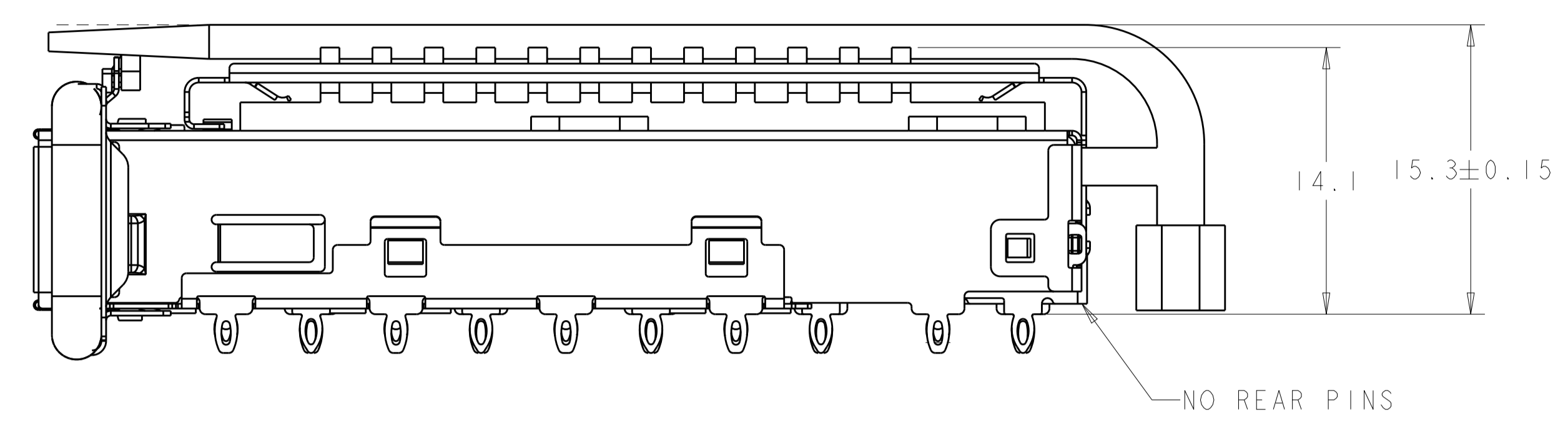
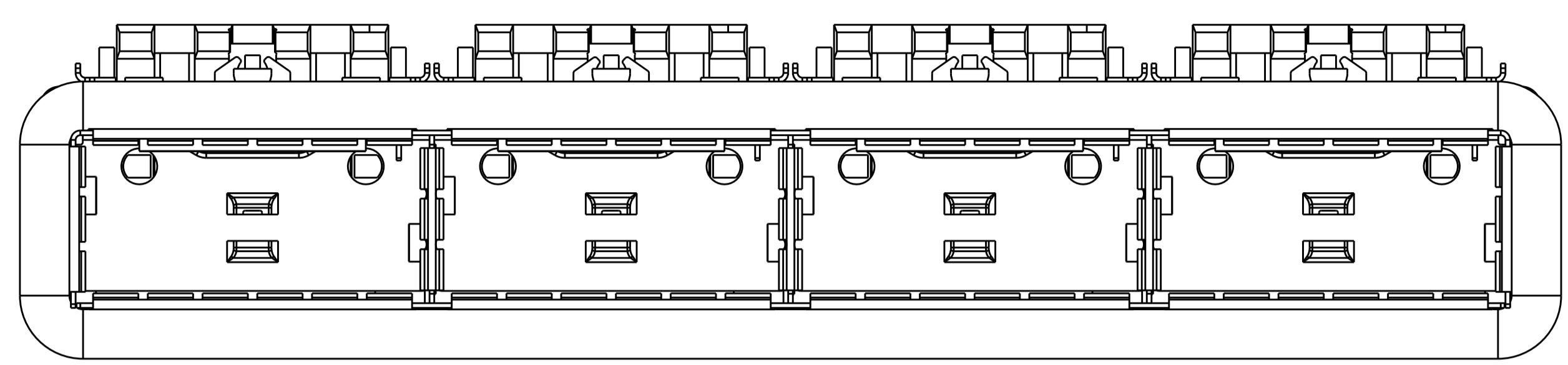

1-2170287-0 shown
SCALE 4:1

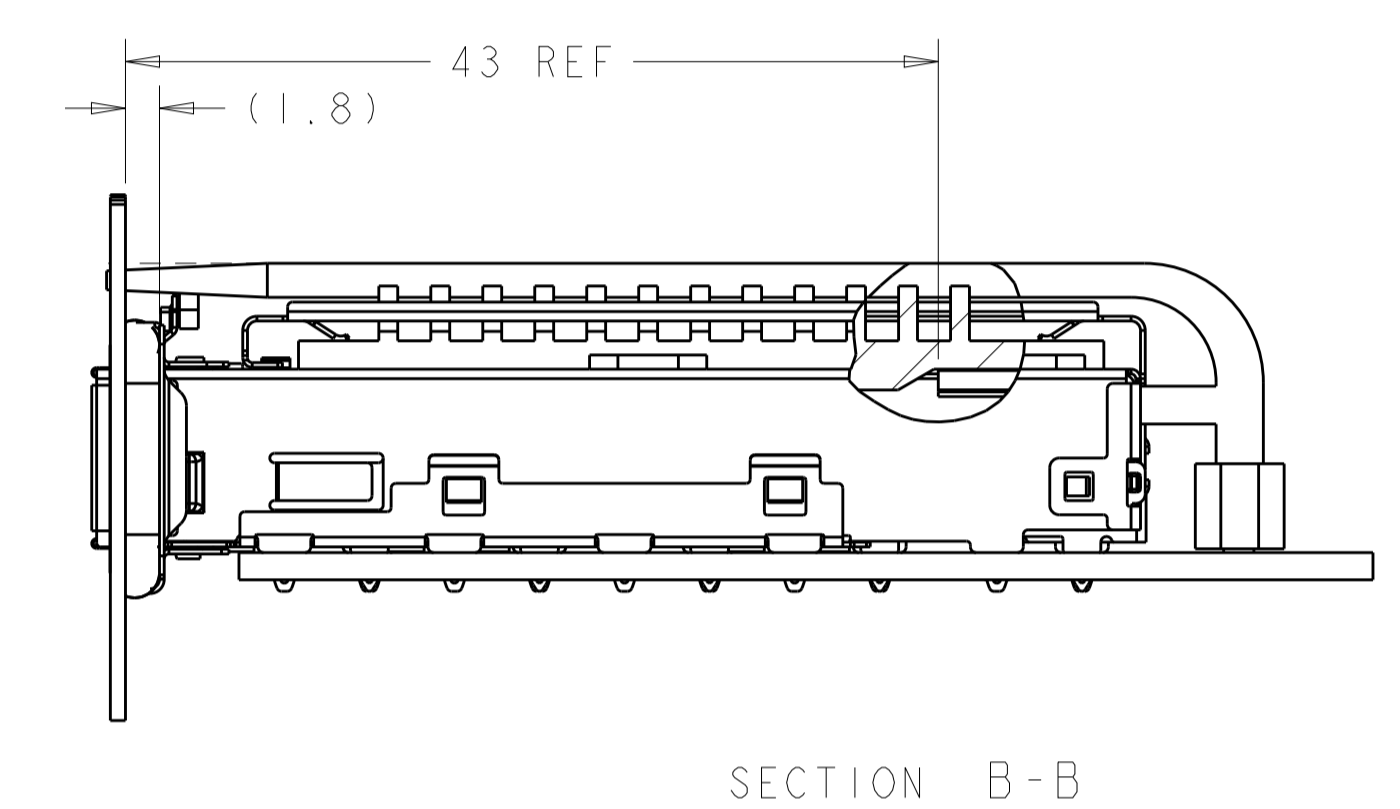
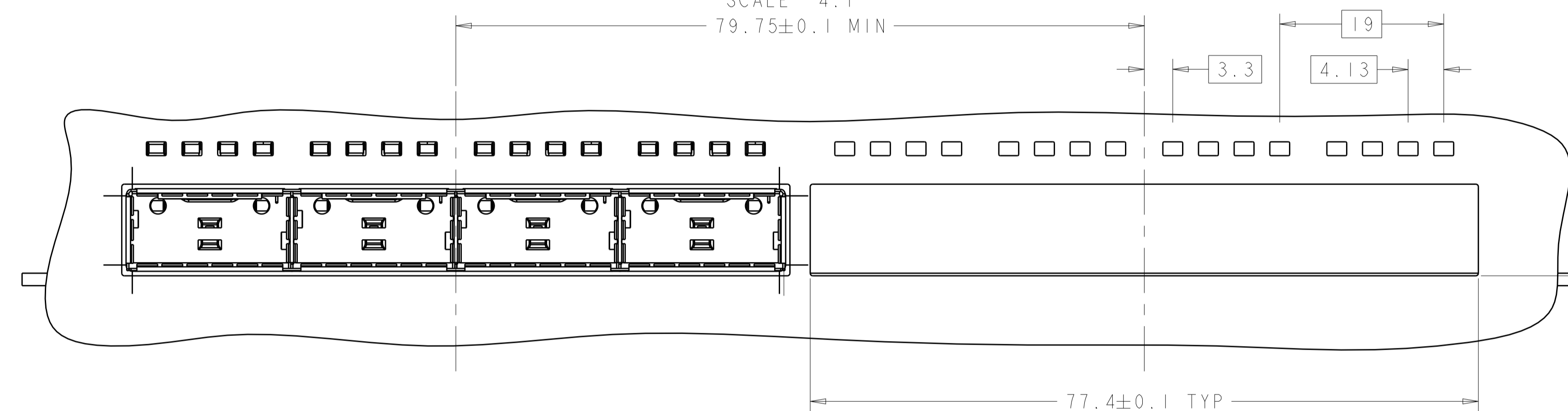

1-2170287-0
ONE SIDED CONFIGURATION
SCALE 5:2

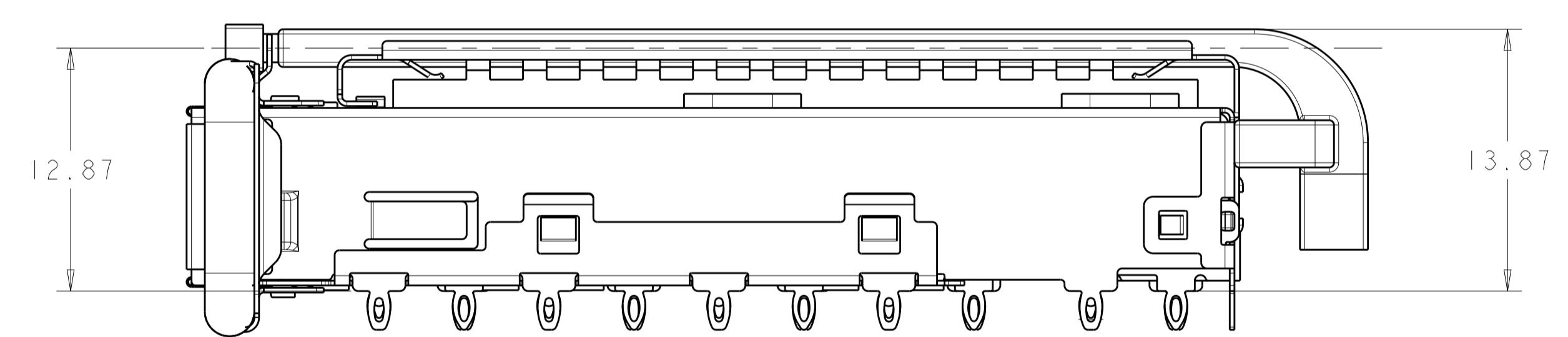
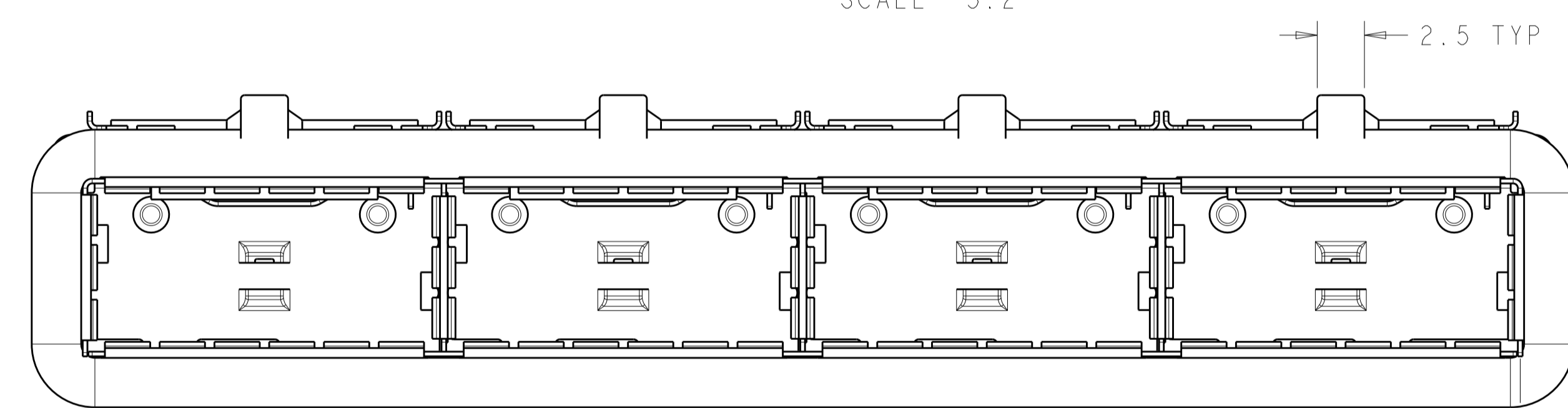

1-2170287-1 SHOWN
SCALE 4:1

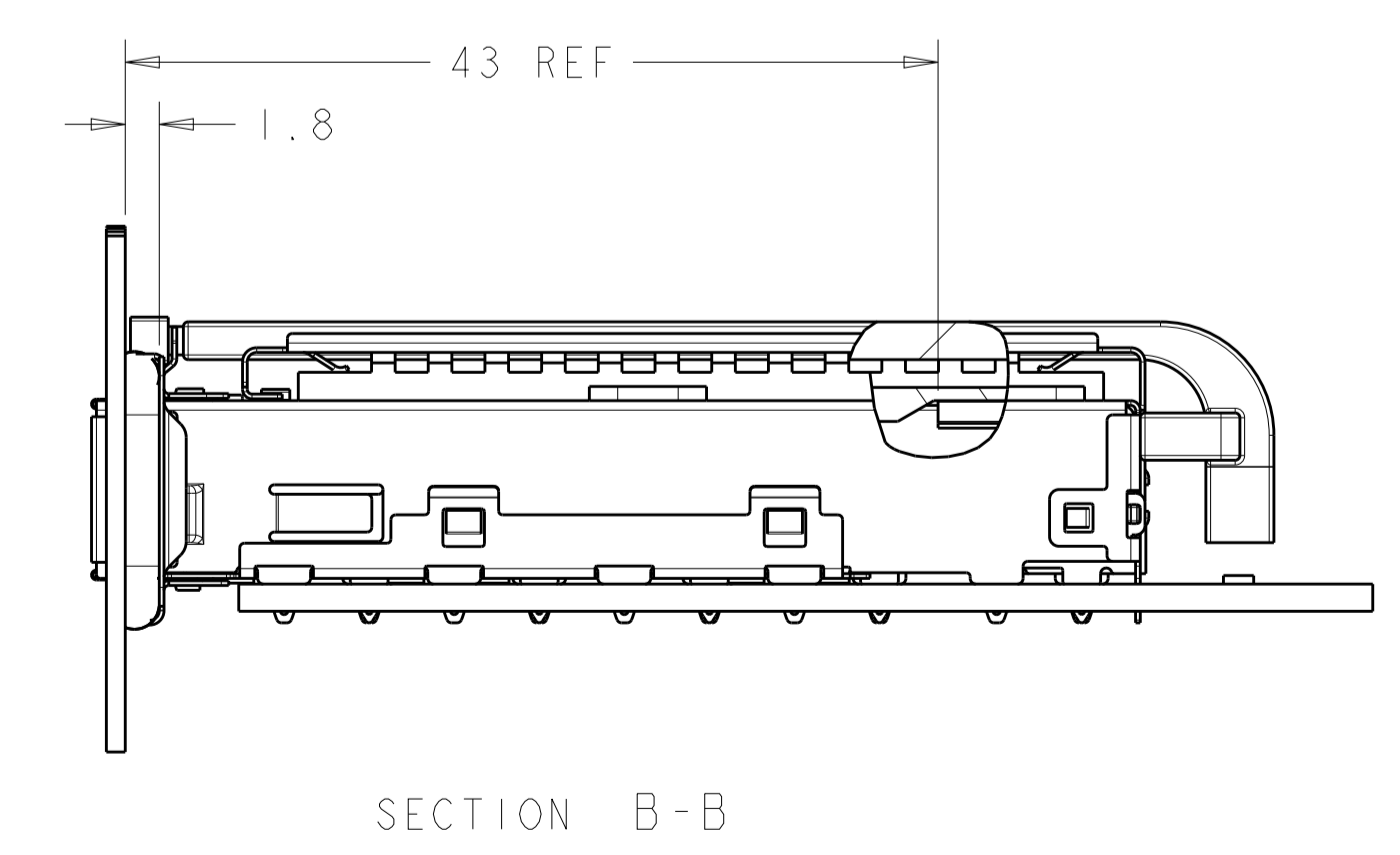
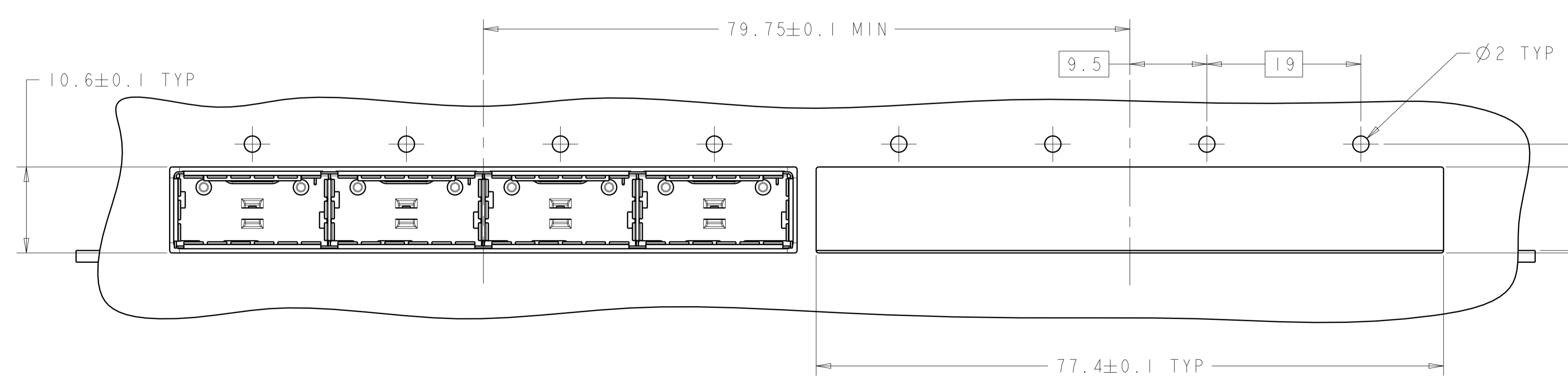

1-2170287-1
ONE SIDED CONFIGURATION
SCALE 5:2

THIS DRAWING IS A CONTROLLED DOCUMENT.		DMN: RINSEN SUN 29FEB2012	TE Connectivity
DIMENSIONS: mm		CHK: DENNY ZHU 29FEB2012	
TOLERANCES UNLESS OTHERWISE SPECIFIED:		APVD: ALEY CAI 29FEB2012	NAME: 1X4 CAGE ASSEMBLY, THRU BEZEL, W/ELASTOMERIC GASKET AND HEAT SINKS, QSFP
0 PLC	±	PRODUCT SPEC	SIZE: CAGE CODE DRAWING NO
1 PLC	±0.35	APPLICATION SPEC	RESTRICTED TO
2 PLC	±0.25	108-2286	A100779C=2170287
3 PLC	±	114-13217	SCALE: 1:1 SHEET 2 OF 8 REV A
4 PLC	±	WEIGHT	
ANGLES	±	CUSTOMER DRAWING	
FINISH			

LOC	DIST	REVISIONS			
P	LTN	DESCRIPTION	DATE	OWN	APVD
GP	00	SEE SHEET 1	-	-	-

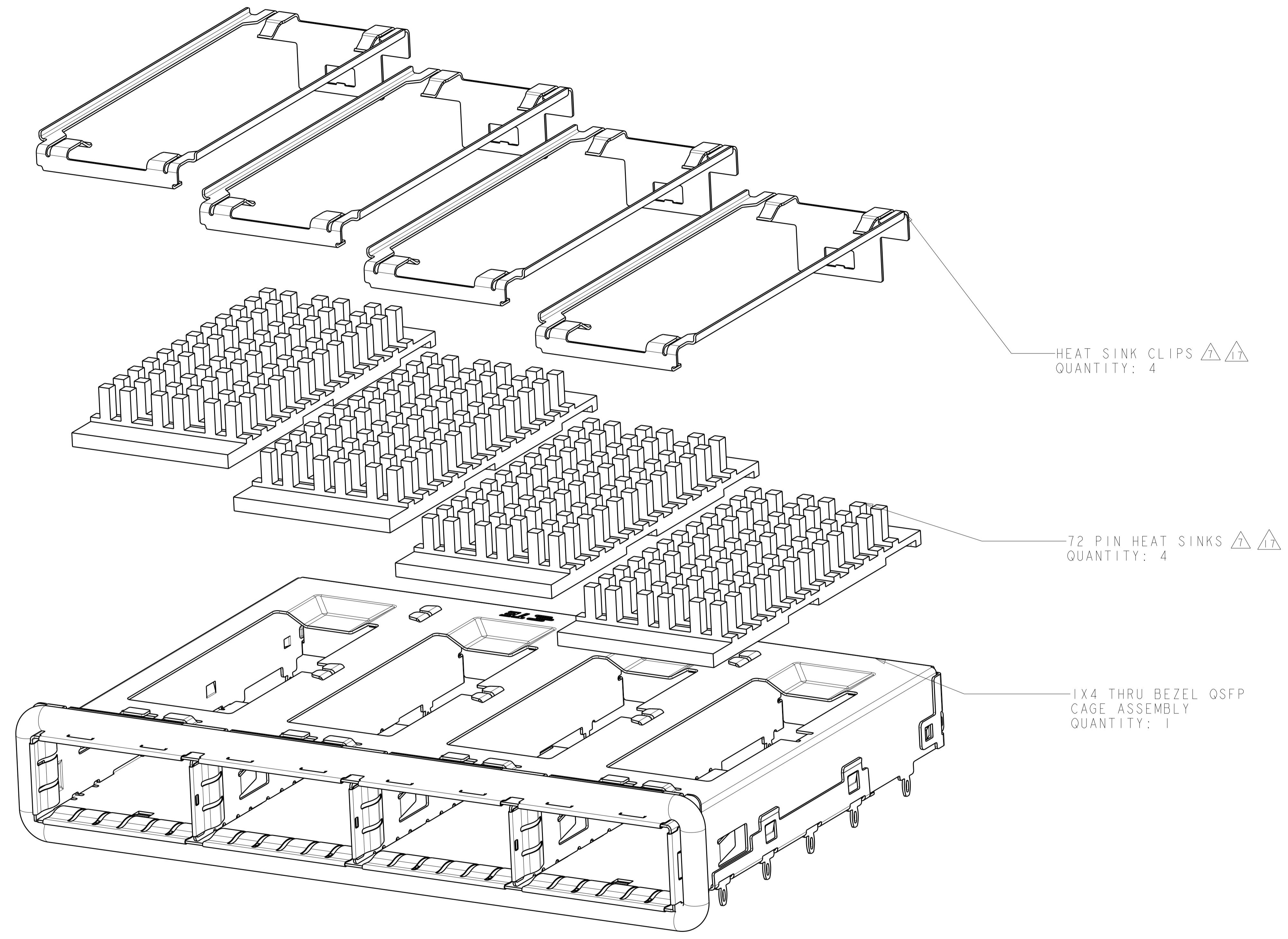

THIS DRAWING IS A CONTROLLED DOCUMENT.		OWN: KINSEN SUN 29FEB2012	TE TE Connectivity
DIMENSIONS: mm		CHK: DENNY ZHU 29FEB2012	
TOLERANCES UNLESS OTHERWISE SPECIFIED:		APVD: AILEY CAI 29FEB2012	NAME: 1X4 CAGE ASSEMBLY, THRU BEZEL, W/ELASTOMERIC GASKET AND HEAT SINKS, QSFP
0 PLC ± .1		PRODUCT SPEC: 108-2286	
1 PLC ±0.35		APPLICATION SPEC: 114-13217	SIZE: A1
2 PLC ±0.25		WEIGHT: -	CAGE CODE: 00779
3 PLC ±		FINISH: -	DRAWING NO: C=2170287
4 PLC ±		CUSTOMER DRAWING	RESTRICTED TO: -
ANGLES ±		SCALE: 1:1	SHEET 3 OF 8
FINISH		REV: A	

LOC	DIST	REVISIONS					
GP	00	P	LTN	DESCRIPTION	DATE	DMN	APVD
-	-	-	-	SEE SHEET 1	-	-	-

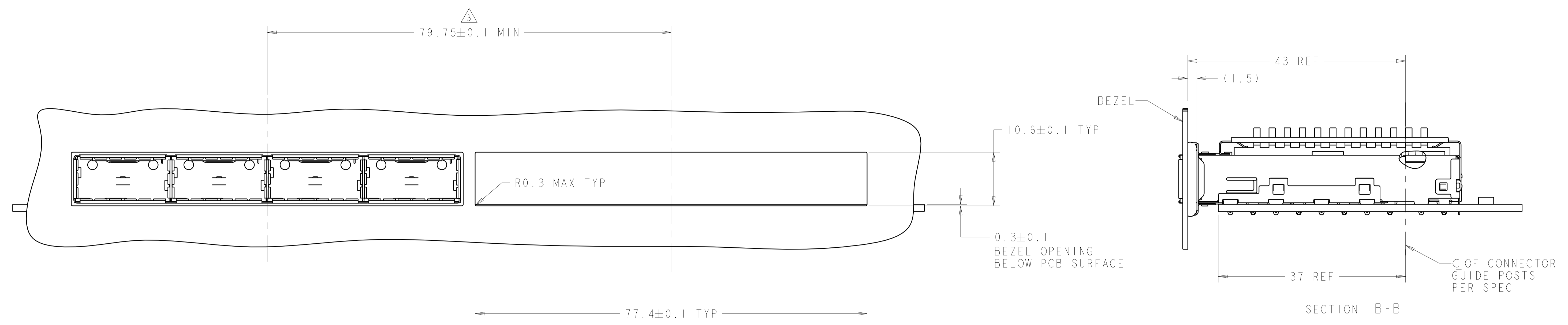

ONE SIDED CONFIGURATION
 SCALE 5:2

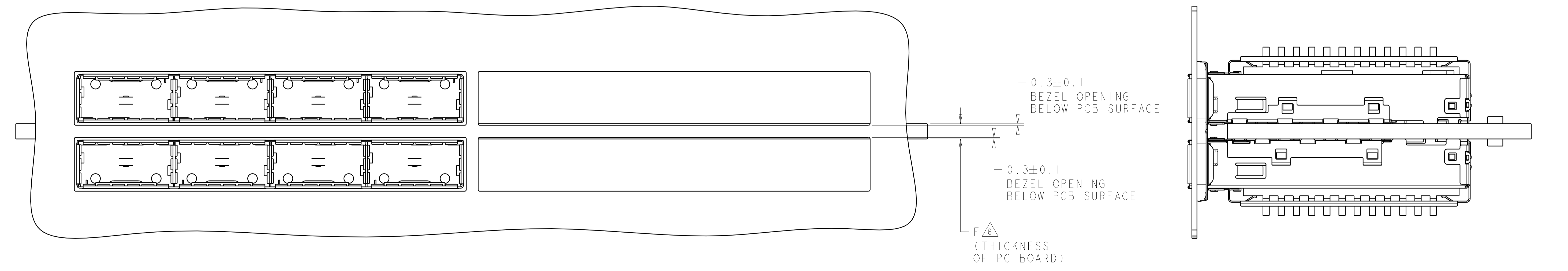

BELLY TO BELLY CONFIGURATION
 SIMILAR TO ONE SIDED
 EXCEPT WHERE NOTED
 SCALE 5:2

THIS DRAWING IS A CONTROLLED DOCUMENT.		DMN: RINSEN SUN 29FEB2012	TE Connectivity
DIMENSIONS: mm		CHK: DENNY ZHU 29FEB2012	
TOLERANCES UNLESS OTHERWISE SPECIFIED:		APVD: AILEY CAI 29FEB2012	NAME: 1X4 CAGE ASSEMBLY, THRU BEZEL, W/ELASTOMERIC GASKET AND HEAT SINKS, QSFP
0 PLC ±	1 PLC ±0.35	PRODUCT SPEC	SIZE: CAGE CODE DRAWING NO
2 PLC ±0.25	3 PLC ±	108-2286	RESTRICTED TO
4 PLC ±	ANGLES ±	APPLICATION SPEC	A100779C=2170287
MATERIAL: -	FINISH: -	114-13217	SCALE: 1:1
CUSTOMER DRAWING		WEIGHT: -	SHEET 4 OF 8
			REV A

LOC	DIST	REV	DATE	BY	APPD
GP	00				

REVISIONS			
NO.	DESCRIPTION	DATE	BY
1	SEE SHEET 1		

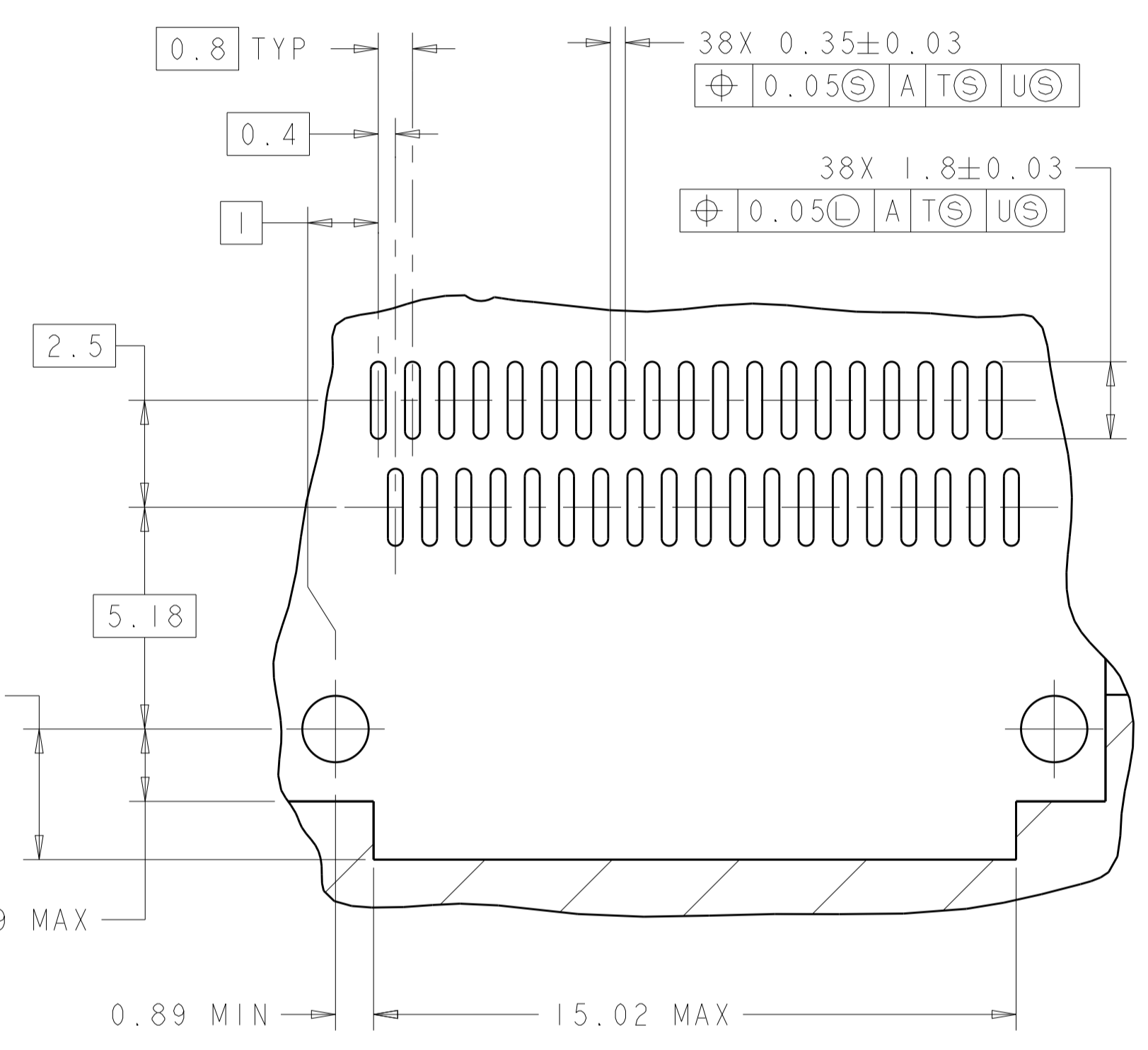
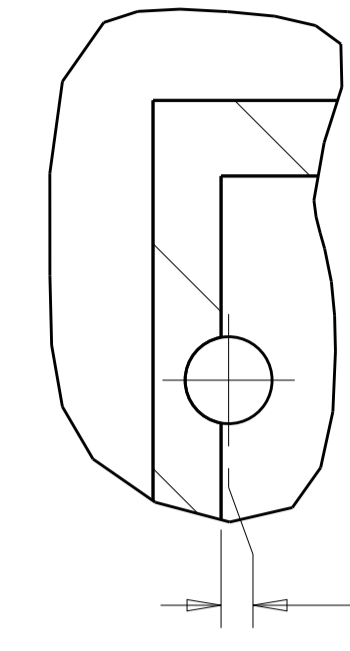
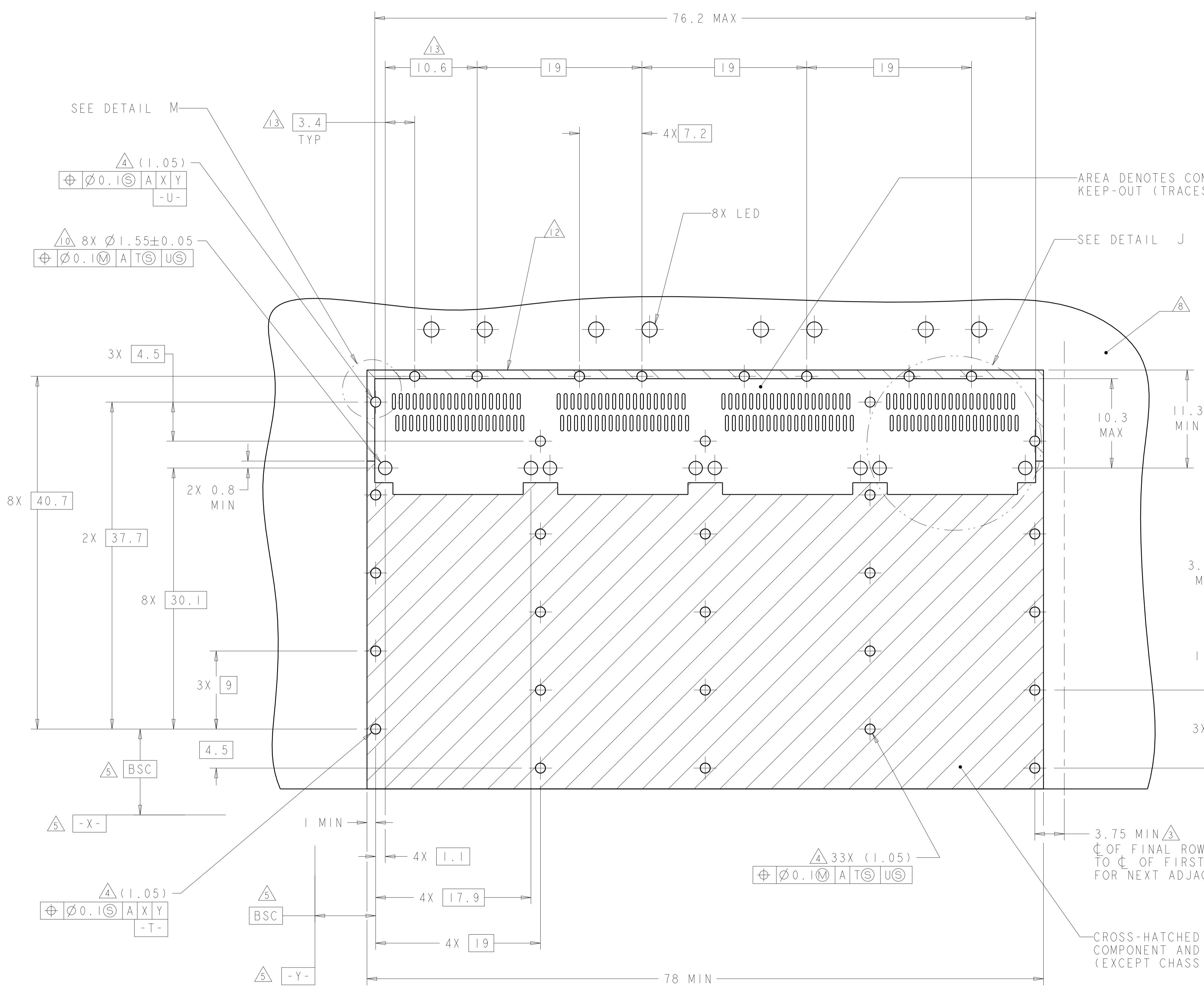

RECOMMENDED PC BOARD LAYOUT
 SINGLE SIDE MOUNT CONFIGURATION
 SCALE 4:1

3.75 MIN Δ 3
 C OF FINAL ROW OF HOLES
 TO C OF FIRST ROW OF HOLES
 FOR NEXT ADJACENT CAGE

CROSS-HATCHED AREA DENOTES
 COMPONENT AND TRACE KEEP-OUT
 (EXCEPT CHASSIS GROUND)

THIS DRAWING IS A CONTROLLED DOCUMENT.		OWN: RINSEN SUN 29FEB2012	TE Connectivity
DIMENSIONS: mm		CHK: DENNY ZHU 29FEB2012	
TOLERANCES UNLESS OTHERWISE SPECIFIED:		APVD: ALEY CAI 29FEB2012	NAME: 1X4 CAGE ASSEMBLY, THRU BEZEL, W/ELASTOMERIC GASKET AND HEAT SINKS, QSFP
0 PLC	±	PRODUCT SPEC	108-2286
1 PLC	±0.35	APPLICATION SPEC	114-13217
2 PLC	±0.25	WEIGHT	A100779C=2170287
3 PLC	±	CUSTOMER DRAWING	SCALE 1:1 SHEET 5 OF 8 REV A
4 PLC	±		
ANGLES	±		
MATERIAL	FINISH		

LOC	DIST	REV	DATE	BY	APPV
GP	00				

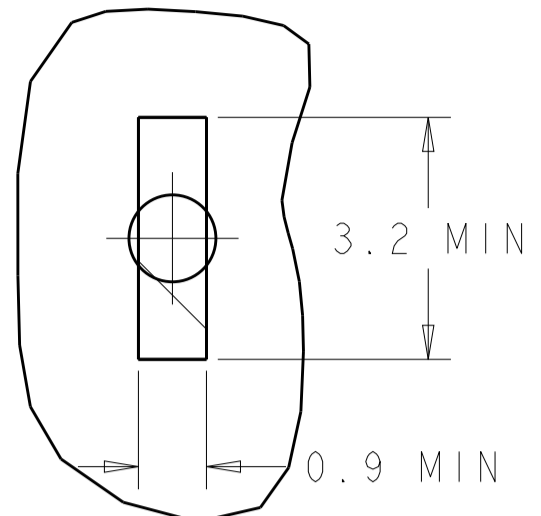

DETAIL M
SCALE 10:1

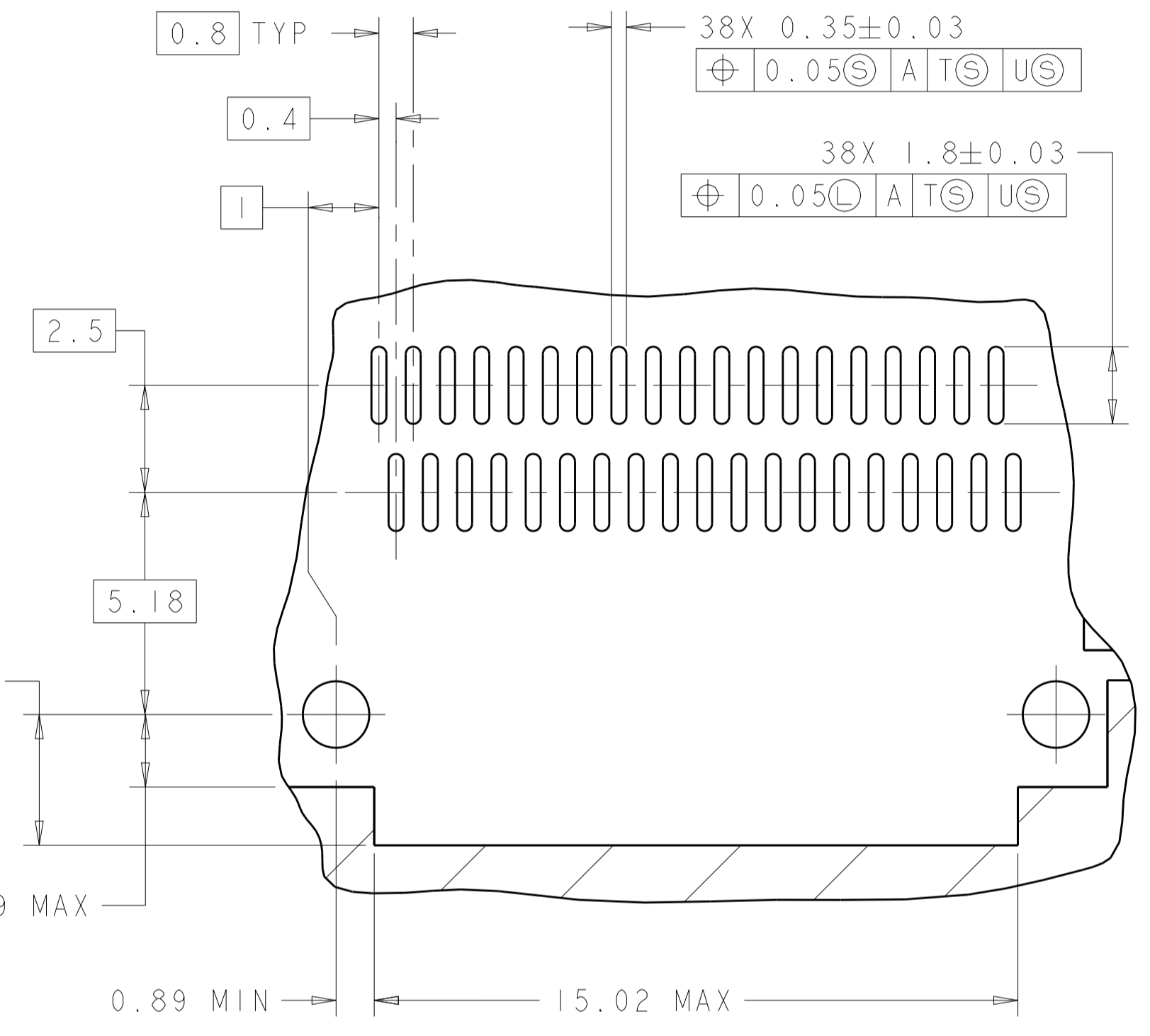
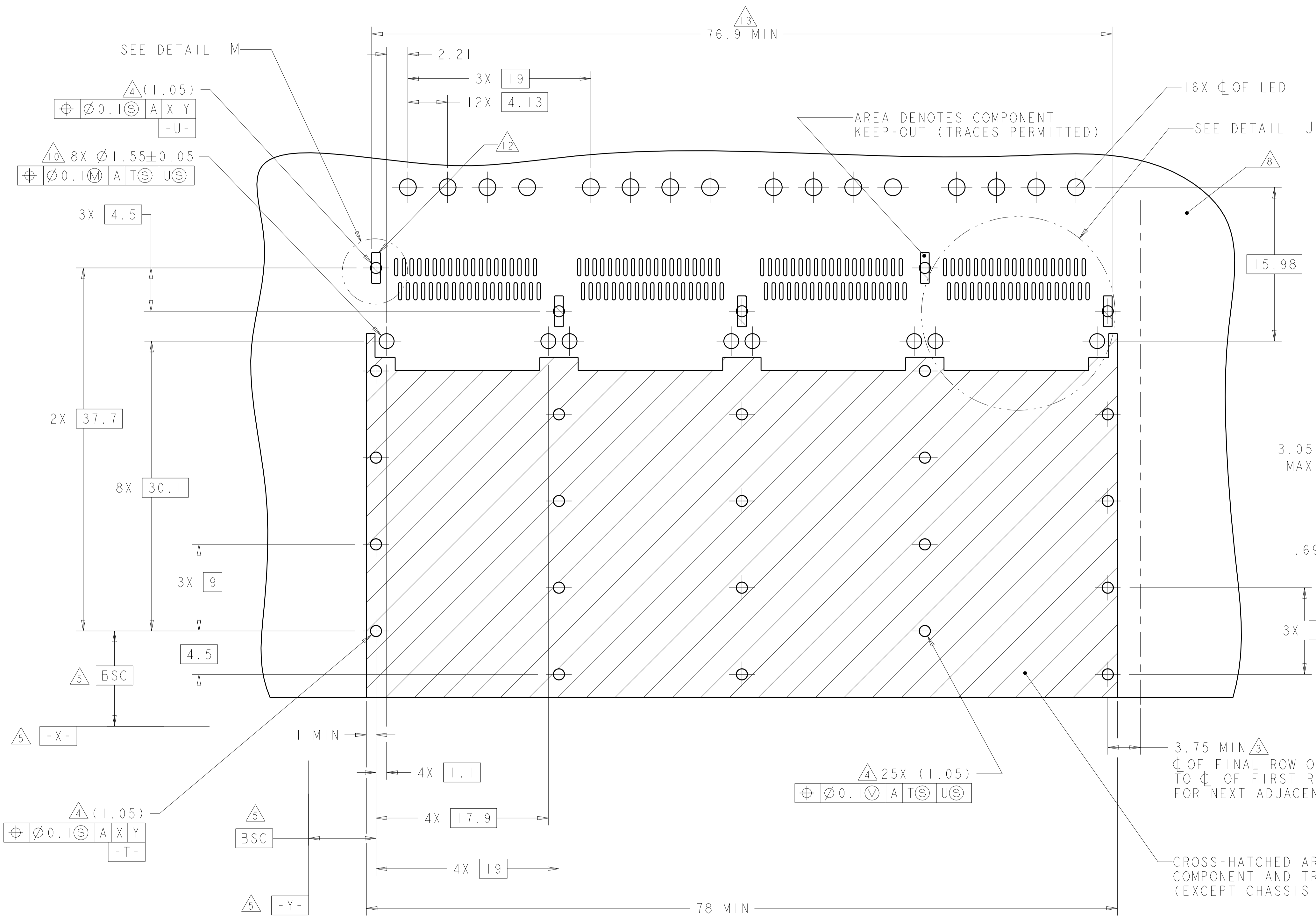

DETAIL J
3 PLACES
SCALE 8:1

RECOMMENDED PC BOARD LAYOUT FOR 1-2170287-0
 SINGLE SIDE MOUNT CONFIGURATION
 SCALE 4:1

THIS PRODUCT HAS NOT COMPLETED VALIDATION/QUALIFICATION TESTING

THIS DRAWING IS A CONTROLLED DOCUMENT.		OWN: KINSEN SUN 29FEB2012	TE Connectivity
DIMENSIONS: mm		CHK: DENNY ZHU 29FEB2012	
TOLERANCES UNLESS OTHERWISE SPECIFIED:		APVD: AILEY CAI 29FEB2012	NAME: 1X4 CAGE ASSEMBLY, THRU BEZEL, W/ELASTOMERIC GASKET AND HEAT SINKS, QSFP
0 PLC ±0.35	1 PLC ±0.25	PRODUCT SPEC: 108-2286	SIZE: 114-13217
2 PLC ±0.25	3 PLC ±0.25	APPLICATION SPEC: 114-13217	RESTRICTED TO: A100779C=2170287
4 PLC ±0.25	5 PLC ±0.25	WEIGHT: -	CUSTOMER DRAWING
ANGLES #	FINISH #	SCALE: 1:1	SHEET 6 OF 8 REV A

LOC	DIST	REVISIONS					
GP	00	P.	LTN	DESCRIPTION	DATE	DMN	APVD
		-		SEE SHEET 1			

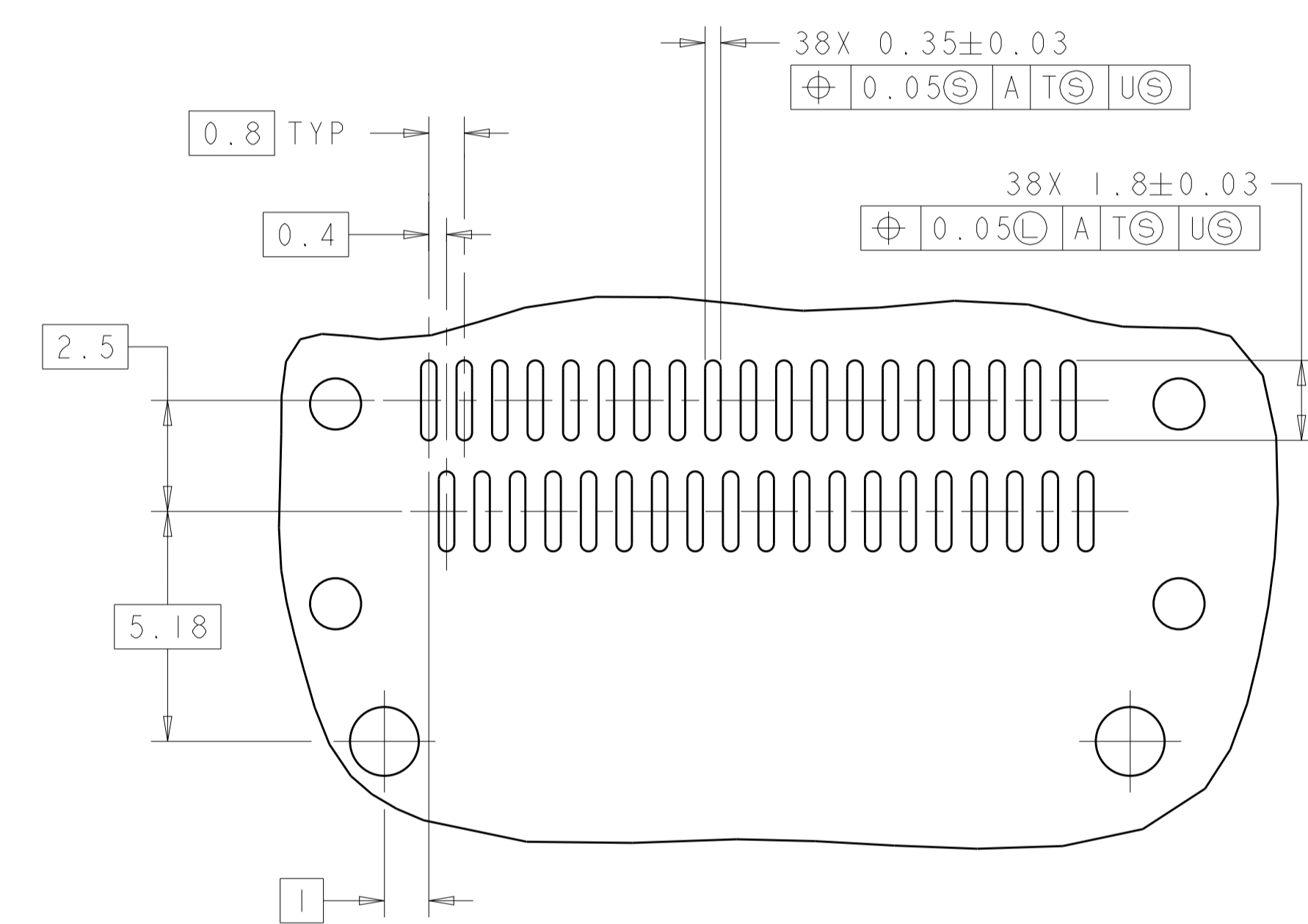
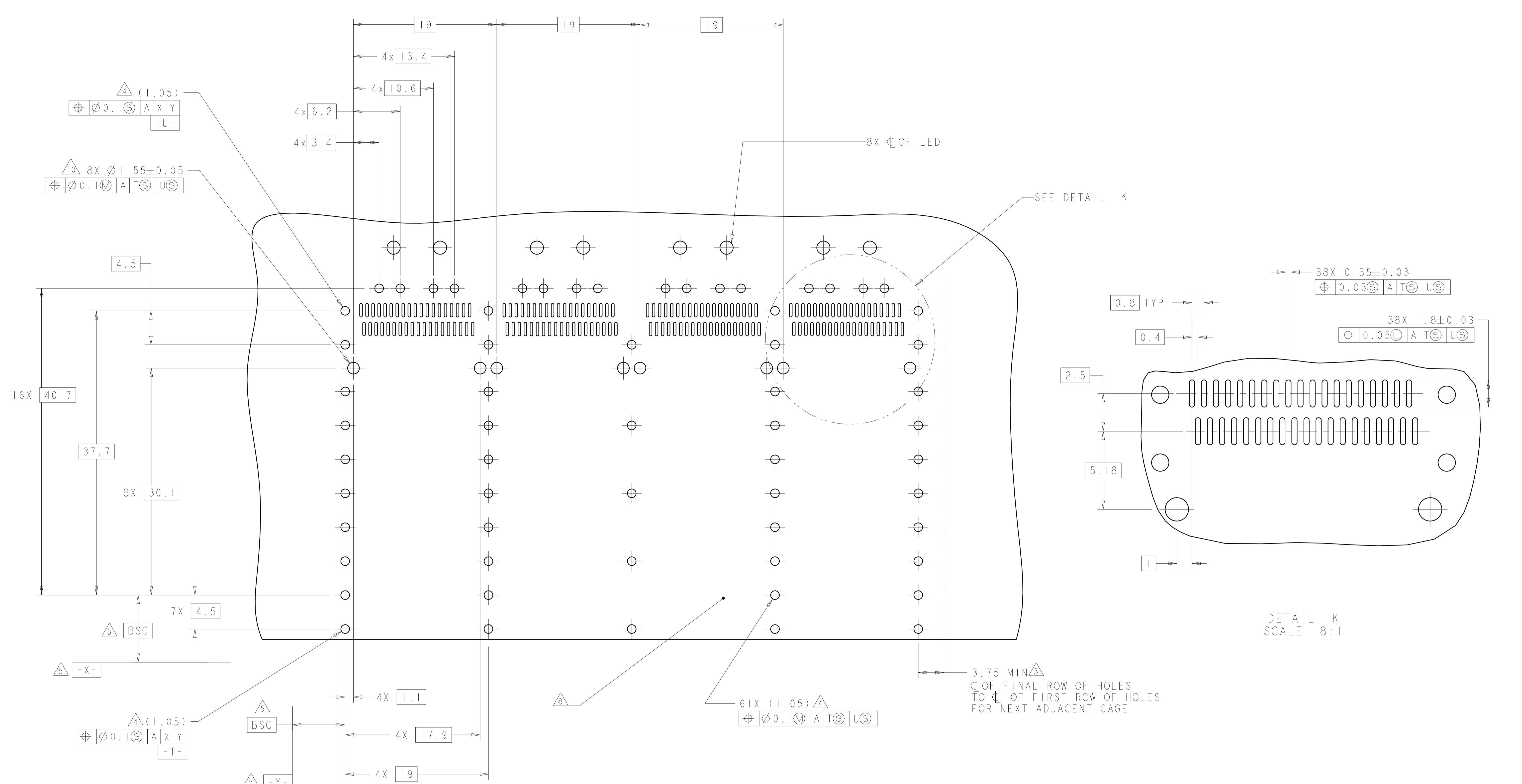

DETAIL K
SCALE 8:1

RECOMMENDED PC BOARD LAYOUT
 BELLY TO BELLY CONFIGURATION
 SEE SHEET 4 FOR COMPONENT AND TRACE KEEP-OUTS
 SCALE 4:1

3.75 MIN Δ
 ϕ OF FINAL ROW OF HOLES
 TO ϕ OF FIRST ROW OF HOLES
 FOR NEXT ADJACENT CAGE

THIS PRODUCT HAS NOT COMPLETED VALIDATION/QUALIFICATION TESTING

THIS DRAWING IS A CONTROLLED DOCUMENT.		DMN: KINSEN SUN 29FEB2012	TE Connectivity
DIMENSIONS: mm		CHK: DENNY ZHU 29FEB2012	
TOLERANCES UNLESS OTHERWISE SPECIFIED:		APVD: ALEY CAI 29FEB2012	NAME: 1X4 CAGE ASSEMBLY, THRU BEZEL, W/ELASTOMERIC GASKET AND HEAT SINKS, QSFP
0 PLC	±	PRODUCT SPEC	SIZE: CAGE CODE DRAWING NO
1 PLC	±0.35	108-2286	RESTRICTED TO
2 PLC	±0.25	APPLICATION SPEC	A100779C=2170287
3 PLC	±	114-13217	SCALE: 1:1 SHEET 8 OF 8 REV A
4 PLC	±	WEIGHT	
ANGLES	±	CUSTOMER DRAWING	
MATERIAL			
FINISH			

X-ON Electronics

Largest Supplier of Electrical and Electronic Components

Click to view similar products for [I/O Connectors](#) category:

Click to view products by [TE Connectivity](#) manufacturer:

Other Similar products are found below :

[571763P](#) [58098-0628](#) [72.250.1628.2](#) [72.250.2428.2](#) [74720-0505](#) [76.350.0729.0](#) [76871-1403](#) [FCN-244F080-G/1](#) [FCN-260A9920](#) [PCR-E36PM](#) [PCS-XE26MA+](#) [G38A71314B](#) [1571250010](#) [157-22500-3](#) [MS3471L14-19P L/C](#) [172501-4002](#) [172501-6002](#) [FCN-260C008-A/L0](#) [FCN-260C024-AL0](#) [FCN-261Z008](#) [2000314-1](#) [200331-1](#) [PCR-E36FC+](#) [PCS-E28FS+](#) [PCS-XE26SLFD+](#) [PCS-XE26SLFDT+](#) [G730VID08BDC24](#) [U90B2054081210](#) [38113800006](#) [DP3AR020WQ1R200](#) [Z4.102.0680.0](#) [500-1040](#) [500-1052](#) [500-1054](#) [ZP-4008-66L](#) [0709821002](#) [DX40-20P\(55\)](#) [5554841-1](#) [MS3474W18-8P-LC*](#) [U90B3054061110](#) [U65-E04-4020](#) [ZPF000000000097891](#) [747360449](#) [10099439-003C-TRLF](#) [10137239-0021LF](#) [E9320-001-01](#) [10137239-0011LF](#) [70289-001LF](#) [70.060.1028.0](#) [109029-ZZ](#)