

THIS DRAWING IS UNPUBLISHED. RELEASED FOR PUBLICATION 20
 © COPYRIGHT 20 BY - ALL RIGHTS RESERVED.

REVISIONS				
P	LTR	DESCRIPTION	DATE	APVD
	A	INITIAL RELEASE	02FEB2016	JY SH

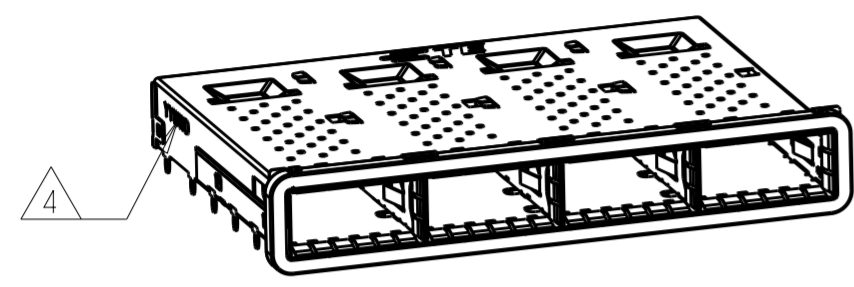

2170782-1, -4 AS SHOWN
SCALE 1:1

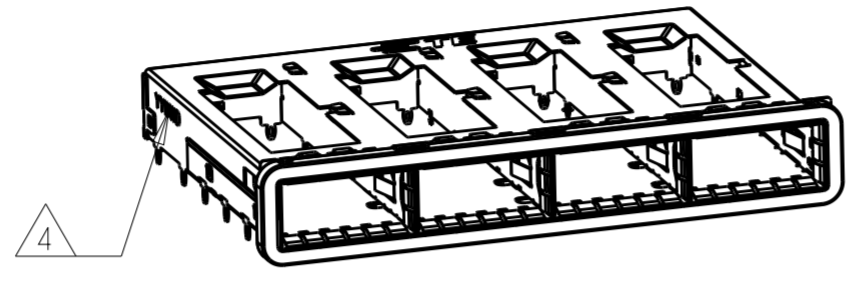

2170782-2, -5 AS SHOWN
SCALE 1:1

1. COMPONENTS
 CAGE ASSEMBLY: NICKEL-SILVER ALLOY
 EMI SPRING: COPPER ALLOY/NICKEL PLATE
 EMI GASKET: PLATED FILLED SILICONE
2. REFERENCE APPLICATION SPECIFICATION 114-32023 FOR RECOMMENDED DRILL HOLE DIAMETER AND PLATING THICKNESS
3. DATUM AND BASIC DIMENSION ESTABLISHED BY CUSTOMER
4. DATE CODE (YYWWD) MARKED APPROXIMATELY AS SHOWN.
5. MATES WITH QSFP28 MSA COMPATIBLE TRANSCEIVER.
6. MINIMUM PC BOARD THICKNESS: SINGLE SIDED: 1.57 MIN
 DOUBLE SIDED: 3.00 MIN
7. DATUM -A- IS TOP SURFACE OF THE HOST BOARD.
8. THESE HOLES ARE OPTIONAL WHEN THE REAR PINS ARE REMOVED.

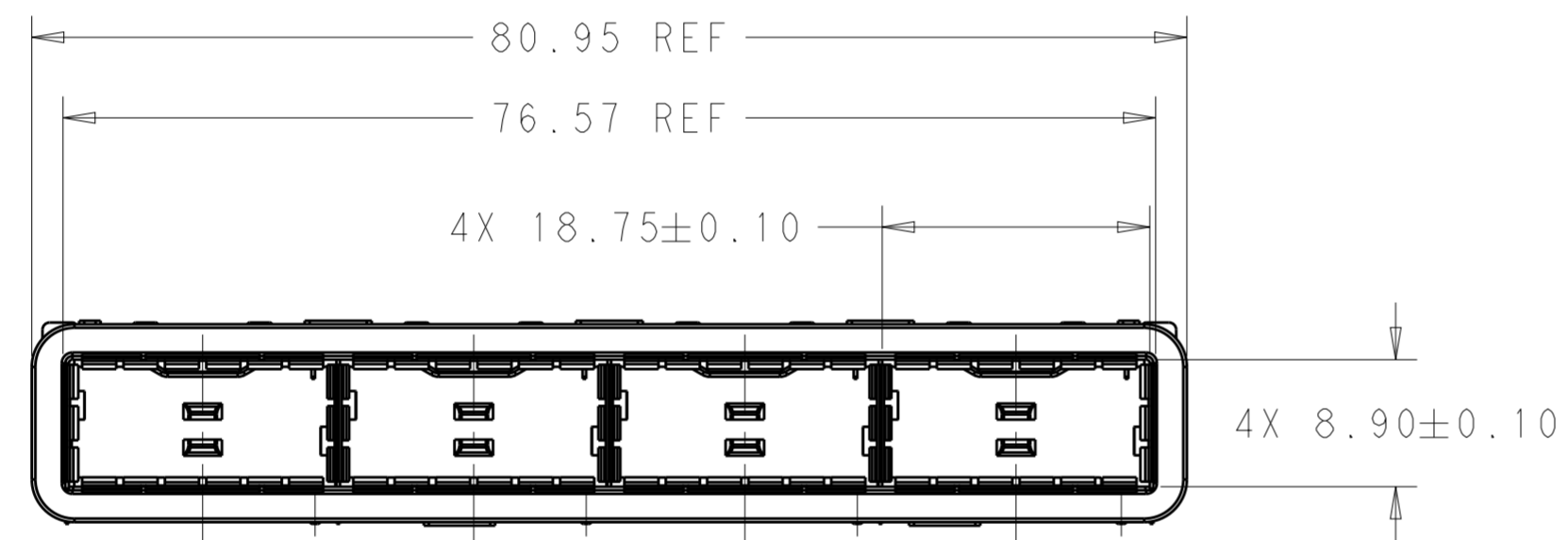

SCALE 2:1

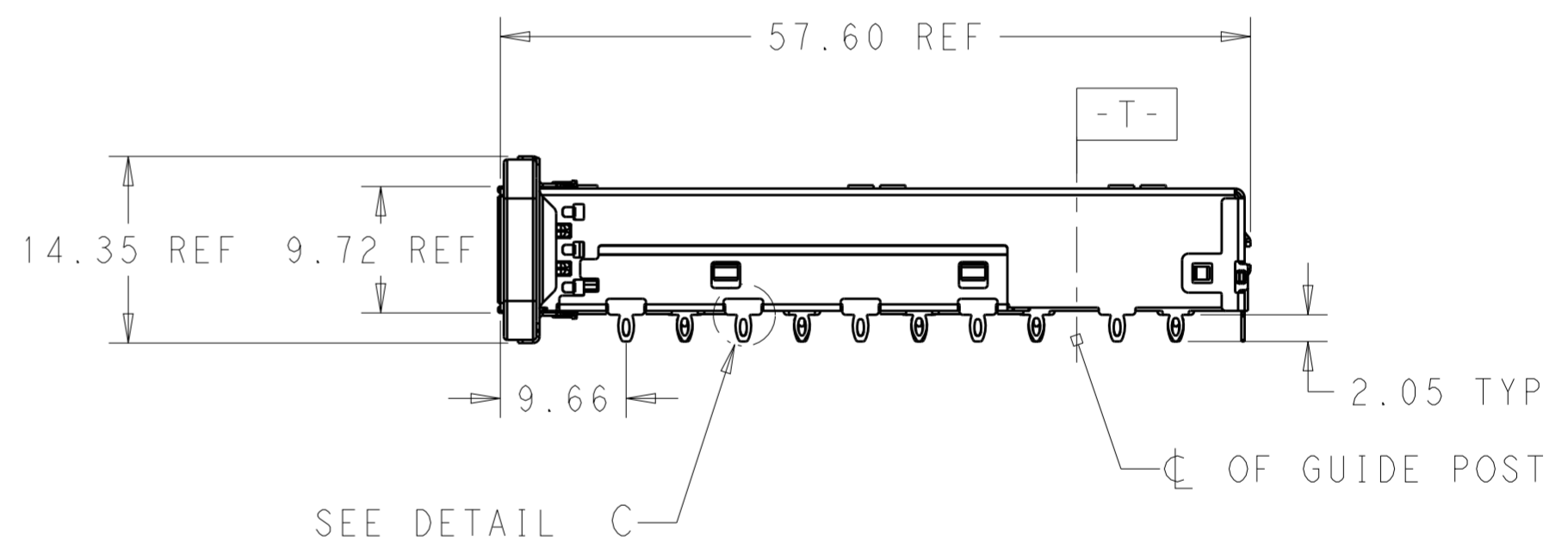

SEE DETAIL C

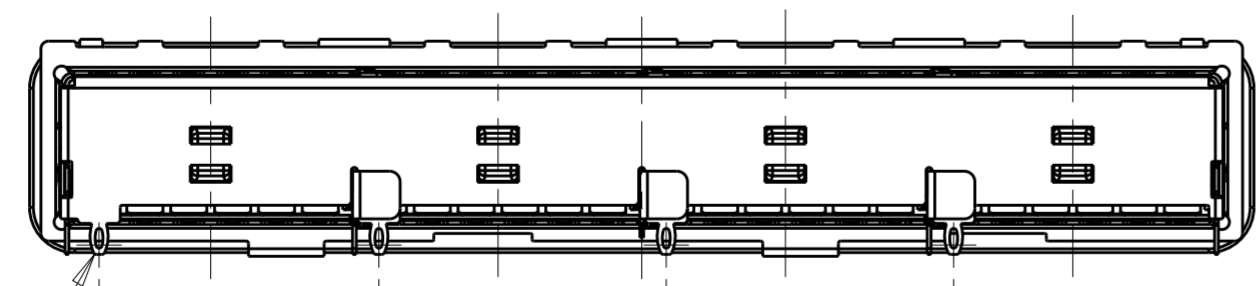

REAR PINS OPTIONAL

BACK VIEW
SCALE 2:1

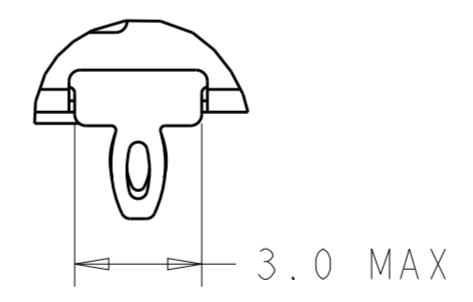

DETAIL C
SCALE 6:1

WITHOUT	WITH	2170782-5
WITHOUT	WITHOUT	2170782-4
WITH	WITH	2170782-2
WITH	WITHOUT	2170782-1
REAR PIN OPTIONAL	HEAT SINK OPEN OPTIONAL	PART NUMBER

THIS DRAWING IS A CONTROLLED DOCUMENT.		DWN 08JUL2014 JASON YANG	TE Connectivity	
		CHK 02FEB2016 SEAN HAN		
DIMENSIONS: mm		APVD -		NAME
TOLERANCES UNLESS OTHERWISE SPECIFIED:		PRODUCT SPEC		RECEPTACLE CAGE ASSEMBLY THRU BEZEL, 1X4, QSFP28, GASKET
0 PLC ±-		108-19428		SIZE
1 PLC ±0.25		APPLICATION SPEC		A200779
2 PLC ±0.2		114-32023		DRAWING NO
3 PLC ±-		WEIGHT -		C-2170782
4 PLC ±-		CUSTOMER DRAWING		RESTRICTED TO
ANGLES ±-		SCALE 1:1		SHEET 1 OF 5
FINISH -		REV A		

THIS DRAWING IS UNPUBLISHED. RELEASED FOR PUBLICATION 20
 © COPYRIGHT 20 BY - ALL RIGHTS RESERVED.

REVISIONS				
P	LTR	DESCRIPTION	DATE	APVD
-	-	SEE SHEET 1	-	-

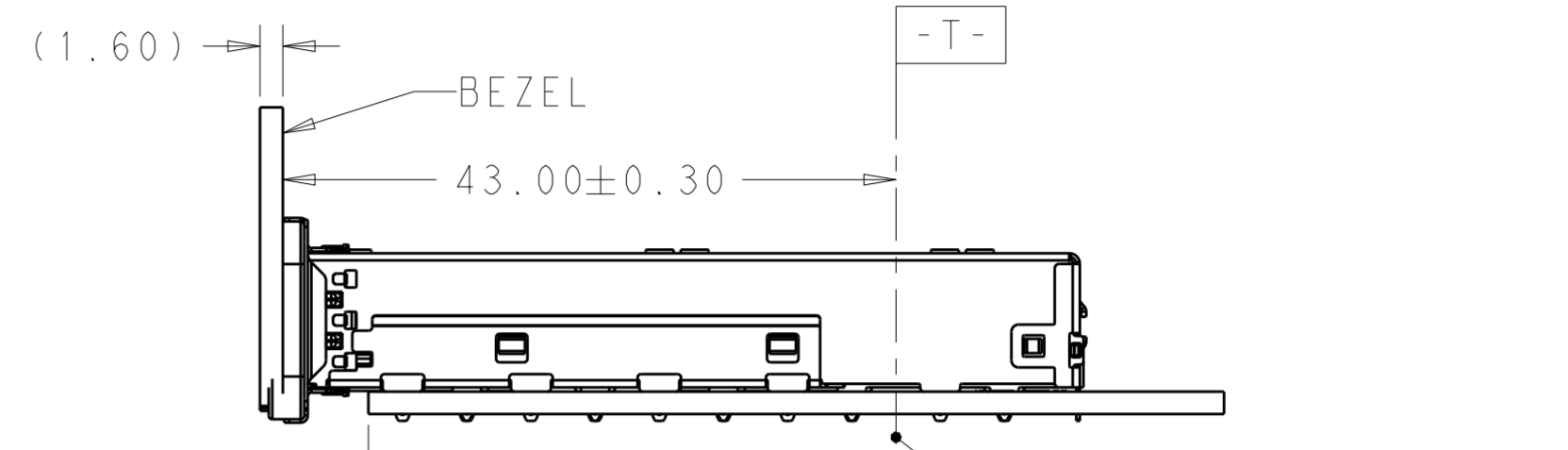
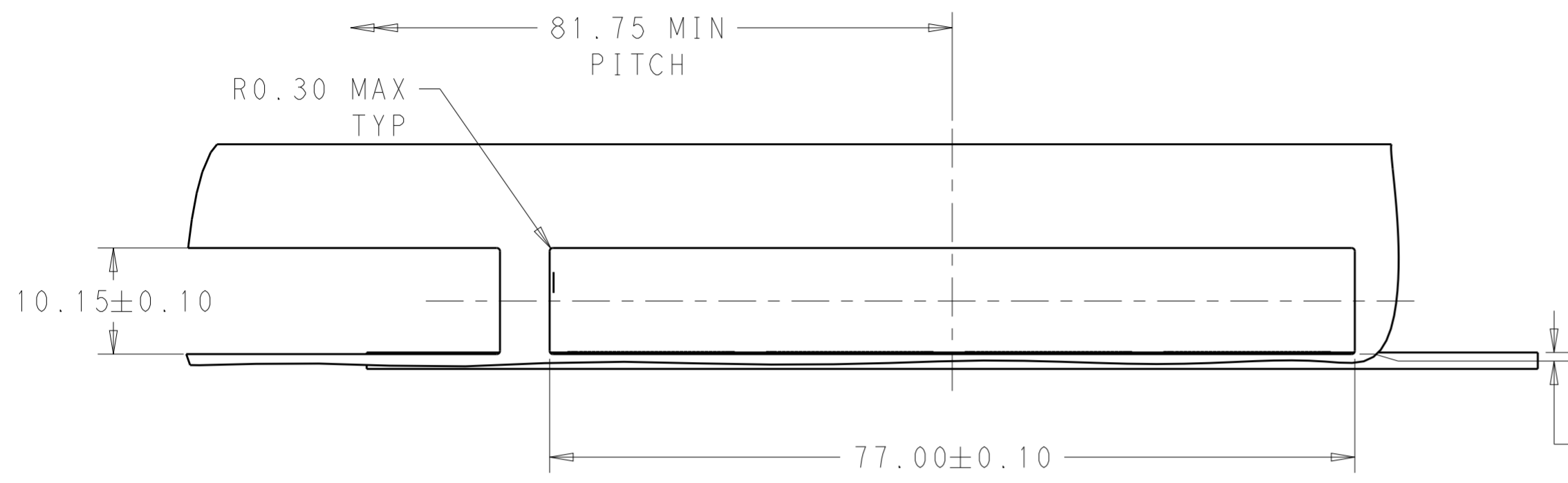

0.15±0.10
 (BOTTOM OF CUT-OUT IN BEZEL TO TOP PCB)

SINGLE SIDE MOUNTING
 SCALE 2:1

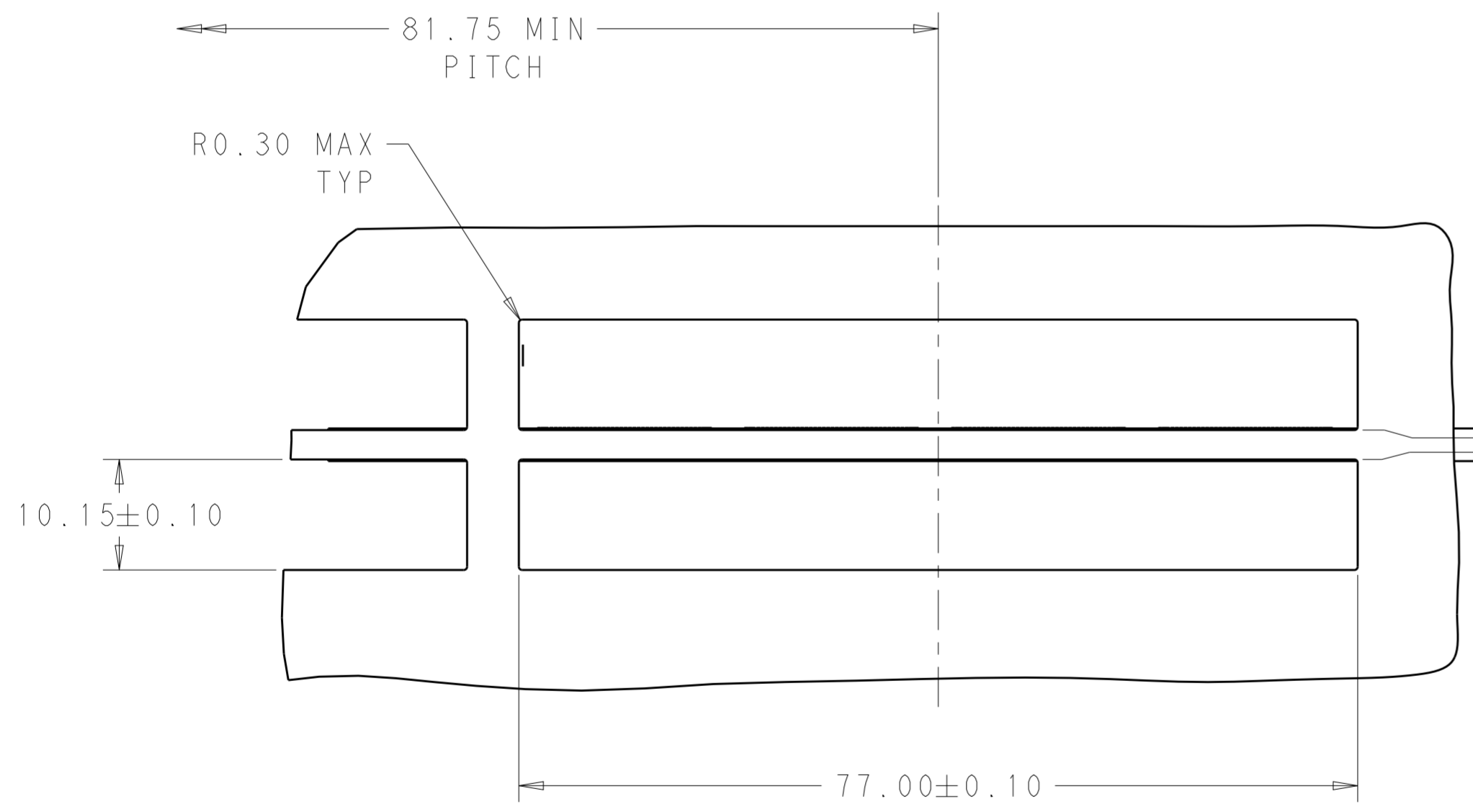

0.15±0.10
 (BOTTOM OF CUT-OUT IN BEZEL TO TOP PCB)

0.15±0.10
 (TOP OF CUT-OUT IN BEZEL TO BOTTOM PCB)

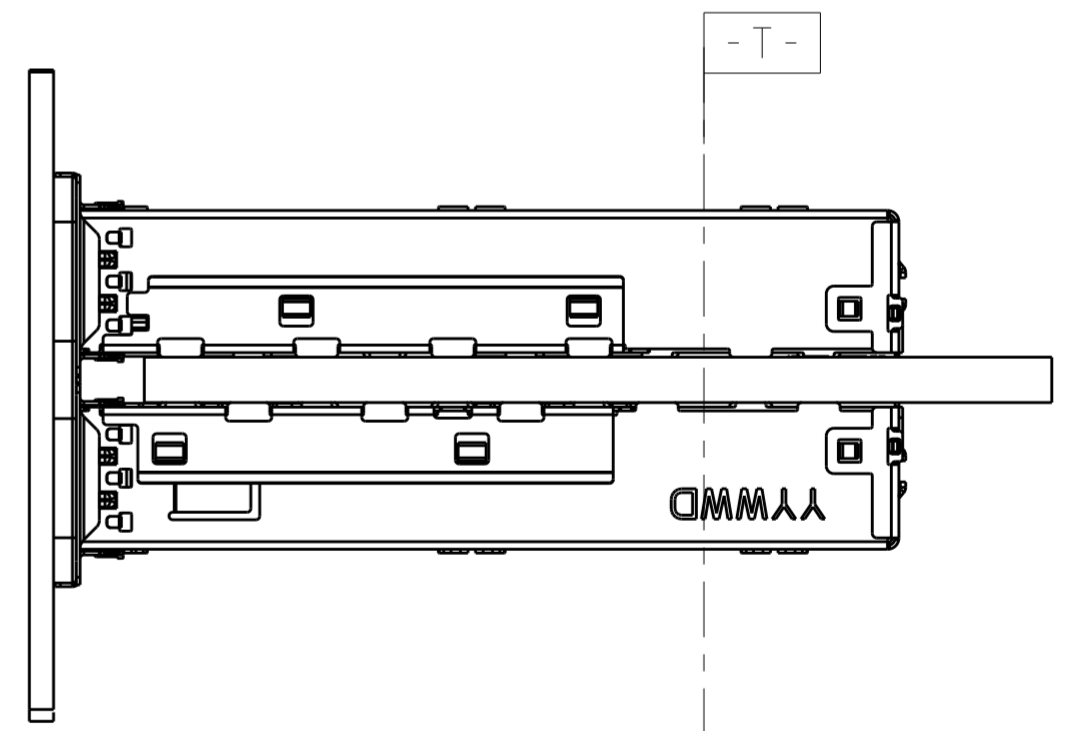

BELLY TO BELLY MOUNTING
 SCALE 2:1

THIS DRAWING IS A CONTROLLED DOCUMENT.		DWN 08JUL2014 JASON YANG	STE TE Connectivity	
		CHK 02FEB2016 SEAN HAN		
DIMENSIONS:	TOLERANCES UNLESS OTHERWISE SPECIFIED:	APVD -	NAME RECEPTACLE CAGE ASSEMBLY THRU BEZEL, 1X4, QSFP28, GASKET	
mm	0 PLC ± 1 PLC ±0.25 2 PLC ±0.2 3 PLC ± 4 PLC ±	PRODUCT SPEC 108-19428	SIZE CAGE CODE DRAWING NO RESTRICTED TO	
MATERIAL SEE NOTES	FINISH SEE NOTES	APPLICATION SPEC 114-32023	A200779 C-2170782	
		WEIGHT -	SCALE 1:1 SHEET 2 OF 5 REV A	
		CUSTOMER DRAWING		

THIS DRAWING IS UNPUBLISHED. RELEASED FOR PUBLICATION 20
 © COPYRIGHT 20 BY - ALL RIGHTS RESERVED.

REVISIONS				
P	LTR	DESCRIPTION	DATE	APVD
-	-	SEE SHEET 1	-	-

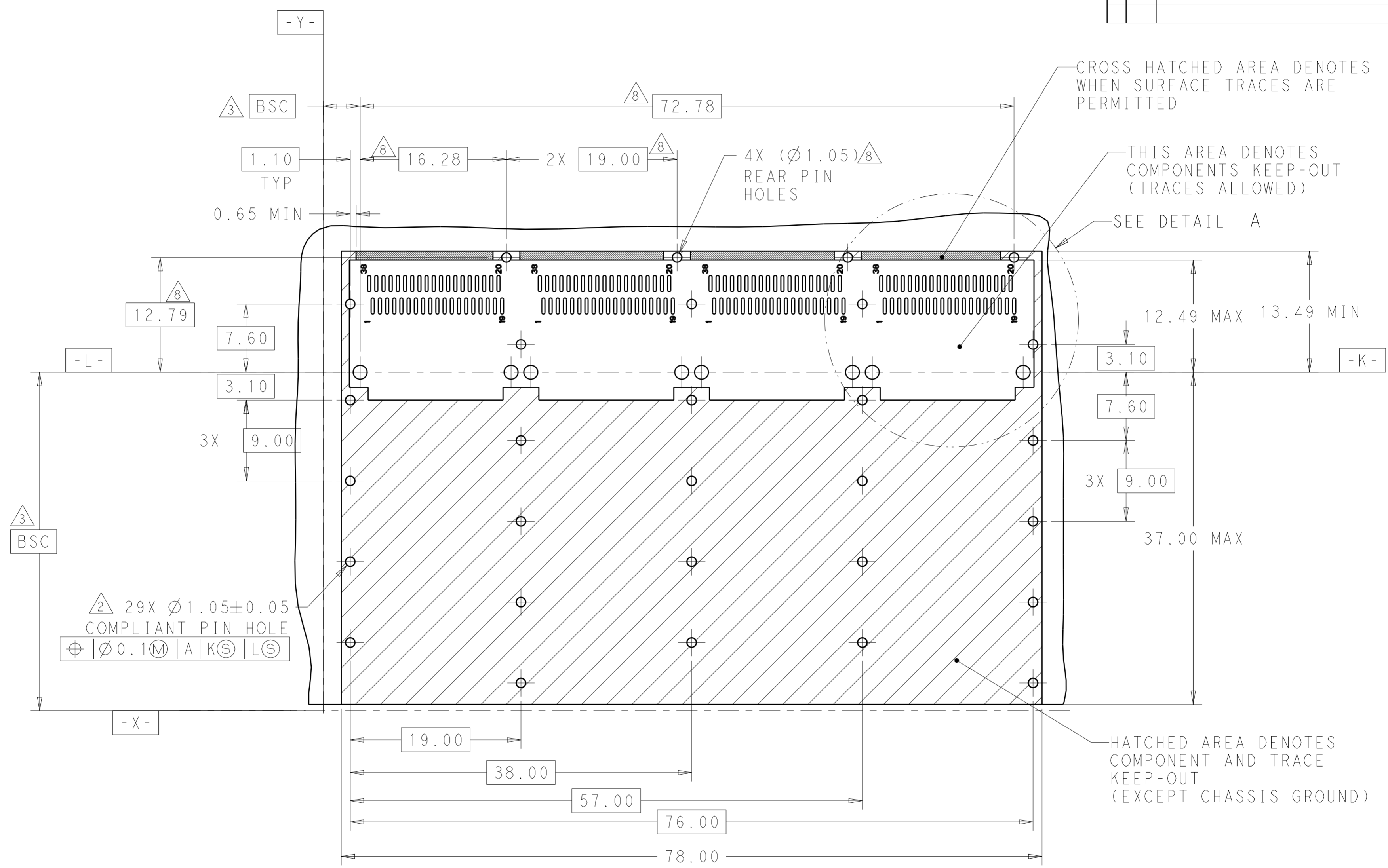

RECOMMENDED PCB LAYOUT
 SINGLE TYPE
 PCB TOLERANCE: ±0.05
 SCALE 3:1

THIS DRAWING IS A CONTROLLED DOCUMENT.		DWN 08JUL2014 JASON YANG	TE Connectivity	
		CHK 02FEB2016 SEAN HAN		
DIMENSIONS: mm		APVD -	NAME RECEPTACLE CAGE ASSEMBLY THRU BEZEL, 1X4, QSFP28, GASKET	
TOLERANCES UNLESS OTHERWISE SPECIFIED:		PRODUCT SPEC 108-19428	RESTRICTED TO -	
0 PLC ±-		APPLICATION SPEC 114-32023	SIZE A200779	DRAWING NO C-2170782
1 PLC ±0.25		WEIGHT -	SCALE 1:1 SHEET 3 OF 5 REV A	
2 PLC ±0.2		CUSTOMER DRAWING		
3 PLC ±-				
4 PLC ±-				
ANGLES ±-				
FINISH SEE NOTES				
MATERIAL SEE NOTES				

THIS DRAWING IS UNPUBLISHED. RELEASED FOR PUBLICATION 20
 © COPYRIGHT 20 BY - ALL RIGHTS RESERVED.

REVISIONS				
P	LTR	DESCRIPTION	DATE	APVD
-	-	SEE SHEET 1	-	-

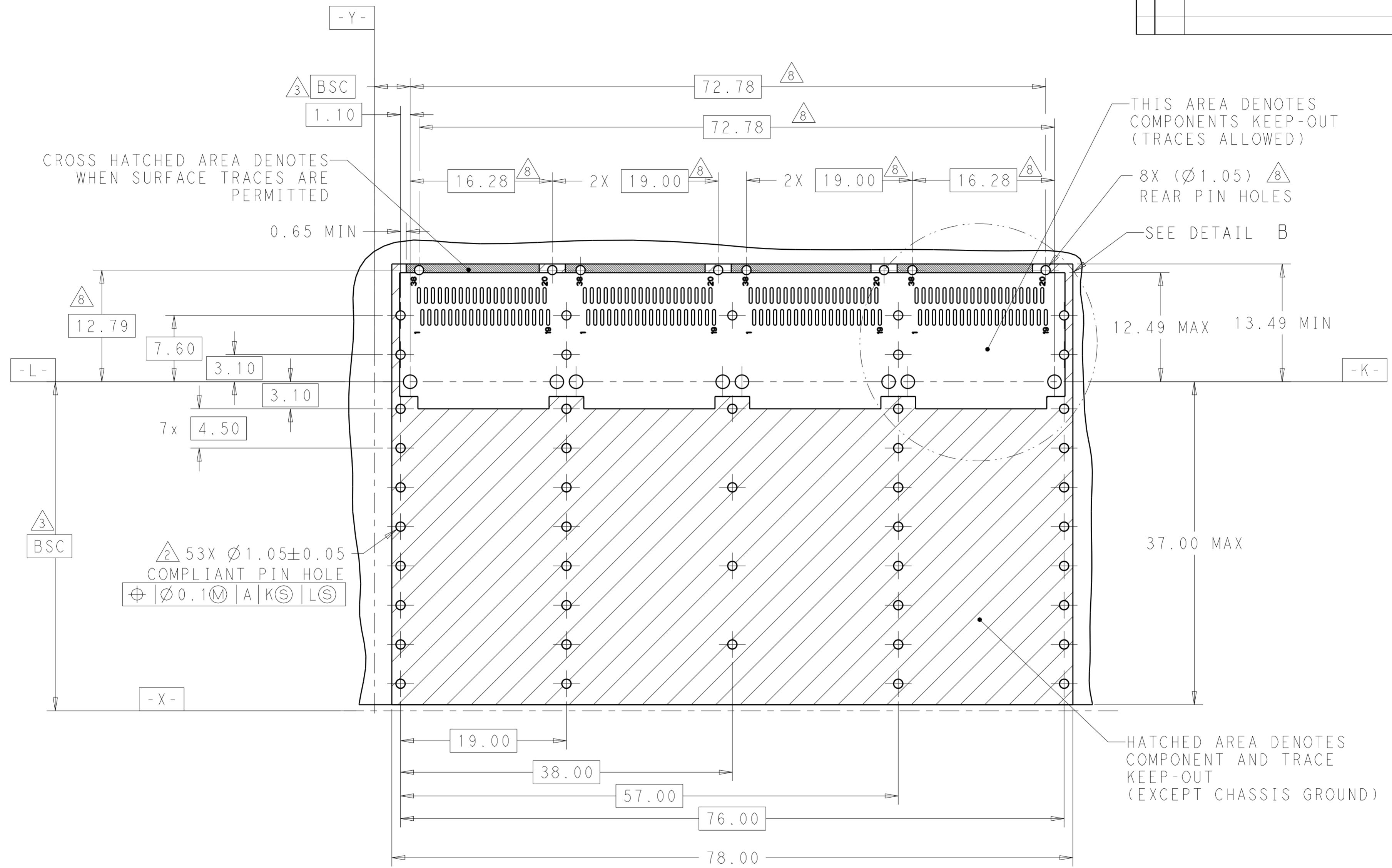

RECOMMENDED PCB LAYOUT
 BELLY TO BELLY TYPE
 PCB TOLERANCE: ±0.05
 SCALE 3:1

THIS DRAWING IS A CONTROLLED DOCUMENT.		DWN JASON YANG 08JUL2014	TE Connectivity	
		CHK SEAN HAN 02FEB2016		
DIMENSIONS: mm		APVD -	NAME RECEPTACLE CAGE ASSEMBLY THRU BEZEL, 1X4, QSFP28, GASKET	
TOLERANCES UNLESS OTHERWISE SPECIFIED: 0 PLC ± 1 PLC ±0.25 2 PLC ±0.2 3 PLC ± 4 PLC ± ANGLES ± FINISH		PRODUCT SPEC 108-19428	RESTRICTED TO	
MATERIAL SEE NOTES		APPLICATION SPEC 114-32023	SIZE A200779	DRAWING NO C-2170782
		WEIGHT -	SCALE 1:1 SHEET 4 OF 5 REV A	
		CUSTOMER DRAWING		

THIS DRAWING IS UNPUBLISHED. RELEASED FOR PUBLICATION 20
 © COPYRIGHT 20 BY - ALL RIGHTS RESERVED.

REVISIONS				
P	LTR	DESCRIPTION	DATE	APVD
-	-	SEE SHEET 1	-	-

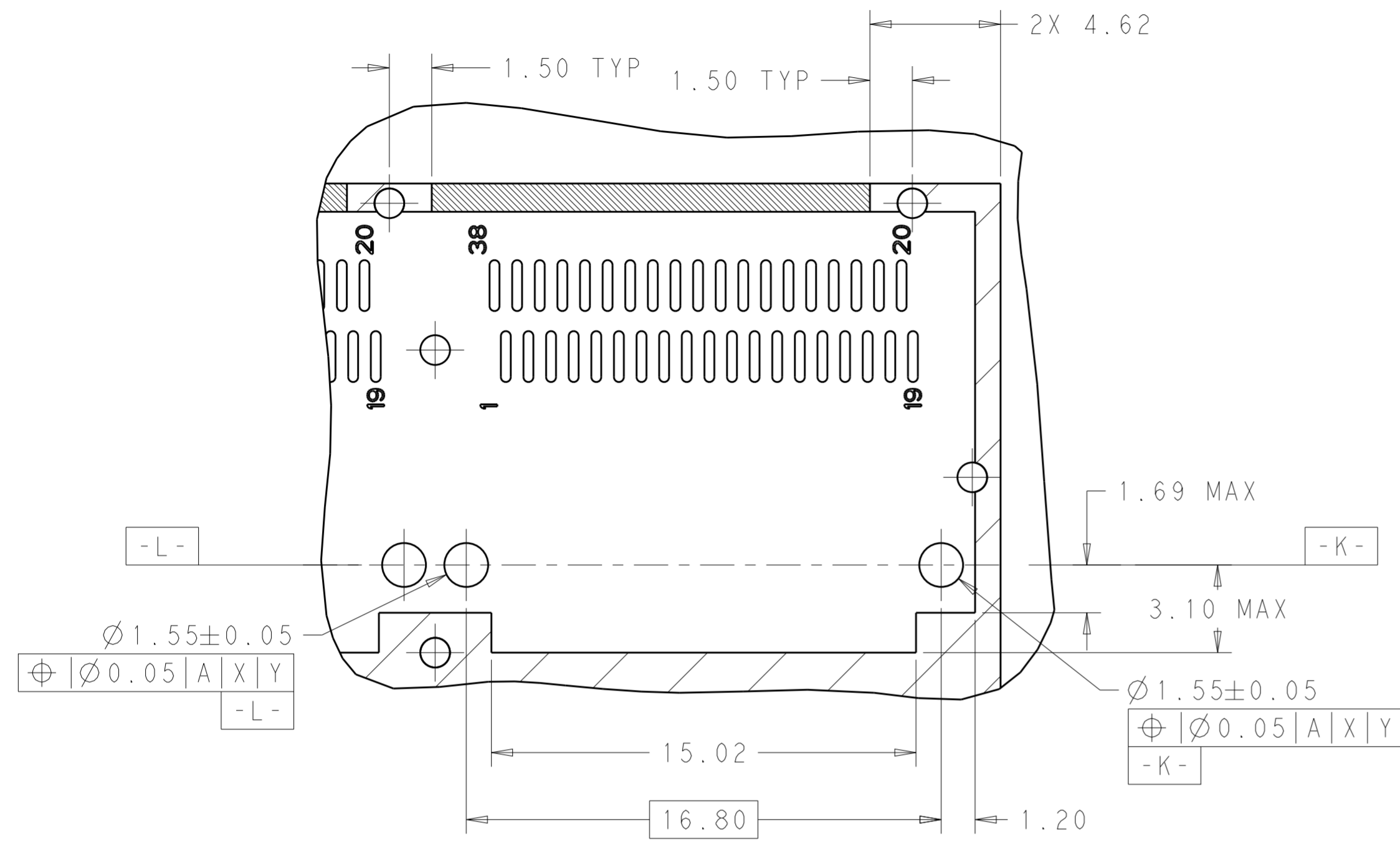

DETAIL A
SCALE 6:1

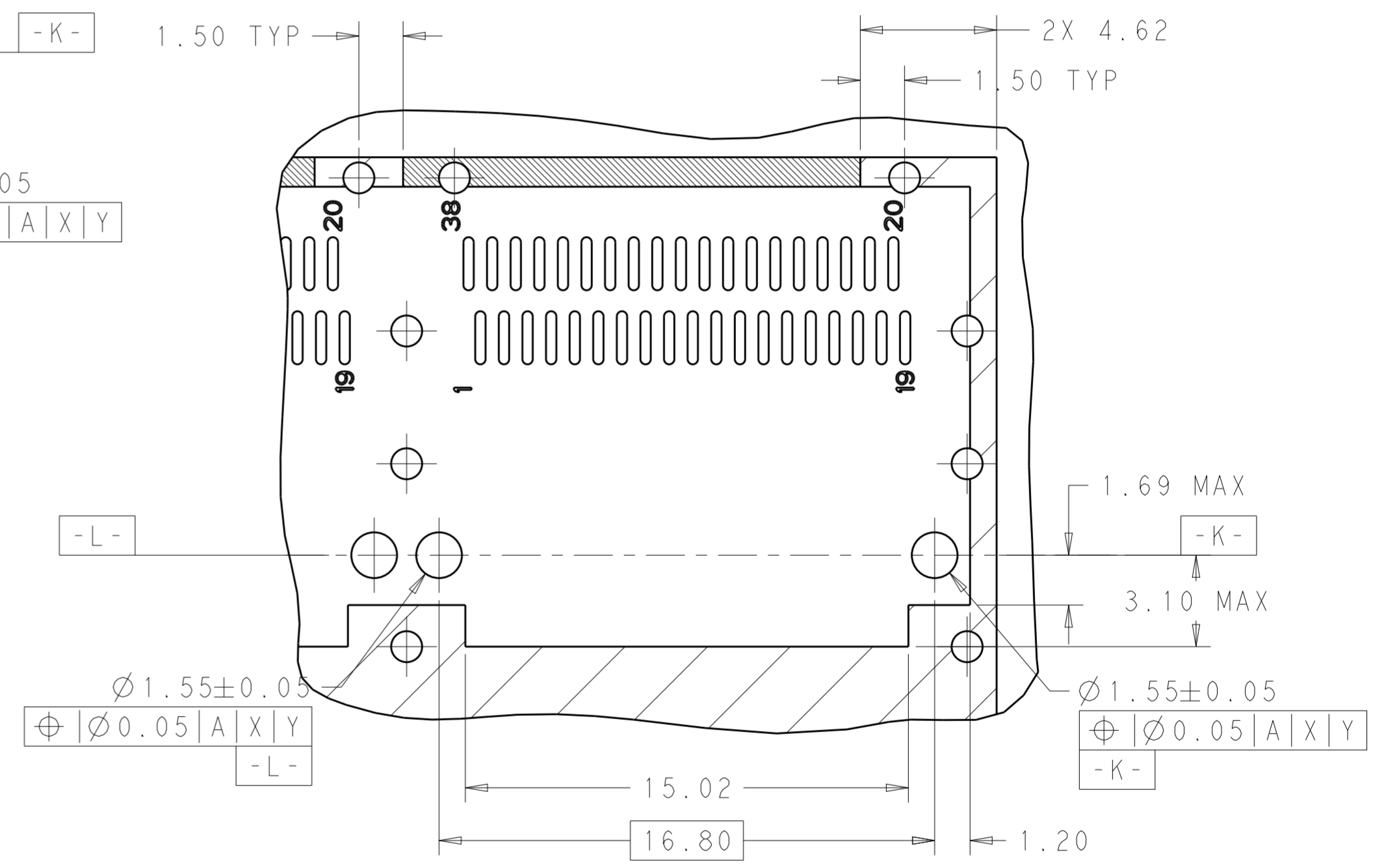

DETAIL B
SCALE 6:1

THIS DRAWING IS A CONTROLLED DOCUMENT.		DWN JASON YANG 08JUL2014	STE TE Connectivity	
		CHK SEAN HAN 02FEB2016		
DIMENSIONS: mm		TOLERANCES UNLESS OTHERWISE SPECIFIED:		NAME RECEPTACLE CAGE ASSEMBLY THRU BEZEL, 1X4, QSFP28, GASKET
0 PLC ±		1 PLC ±0.25		PRODUCT SPEC 108-19428
2 PLC ±0.2		3 PLC ±		APPLICATION SPEC 114-32023
4 PLC ±		ANGLES ±		SIZE A200779
MATERIAL SEE NOTES		FINISH SEE NOTES		CAGE CODE C-2170782
		WEIGHT -		DRAWING NO -
		CUSTOMER DRAWING		RESTRICTED TO -
		SCALE 1:1		SHEET 5 OF 5
				REV A

X-ON Electronics

Largest Supplier of Electrical and Electronic Components

Click to view similar products for [I/O Connectors](#) category:

Click to view products by [TE Connectivity](#) manufacturer:

Other Similar products are found below :

[571763P](#) [58098-0628](#) [72.250.1628.2](#) [72.250.2428.2](#) [74720-0505](#) [76.350.0729.0](#) [76871-1403](#) [FCN-244F080-G/1](#) [FCN-260A9920](#) [PCR-E36PM](#) [PCS-XE26MA+](#) [G38A71314B](#) [DX40-50P\(55\)](#) [1571250010](#) [157-22500-3](#) [MS3471L14-19P L/C](#) [91-569786-35H](#) [172501-4002](#) [172501-6002](#) [FCN-260C008-A/L0](#) [FCN-260C024-AL0](#) [FCN-261Z008](#) [2000314-1](#) [200331-1](#) [PCR-E36FC+](#) [PCS-E28FS+](#) [PCS-XE26SLFD+](#) [PCS-XE26SLFDT+](#) [G730VID08BDC24](#) [U90B2054081210](#) [UE86K842720321](#) [38113800006](#) [DP3AR020WQ1R200](#) [Z4.102.0680.0](#) [500-1040](#) [500-1052](#) [500-1054](#) [ZP-4008-66L](#) [0709821002](#) [10-565995-597N](#) [DX40-20P\(55\)](#) [5554841-1](#) [MS3474W18-8P-LC*](#) [U90B3054061110](#) [U65-E04-4020](#) [ZPF000000000097891](#) [557-262M2-06C](#) [747360449](#) [10099439-003C-TRLF](#) [10137239-0021LF](#)