

LOC	DIST	REVISIONS					
GP	00	P	LTN	DESCRIPTION	DATE	DWN	APVD
		B		REVISED PER ECR-18-002882	27FEB2018	IT	SH

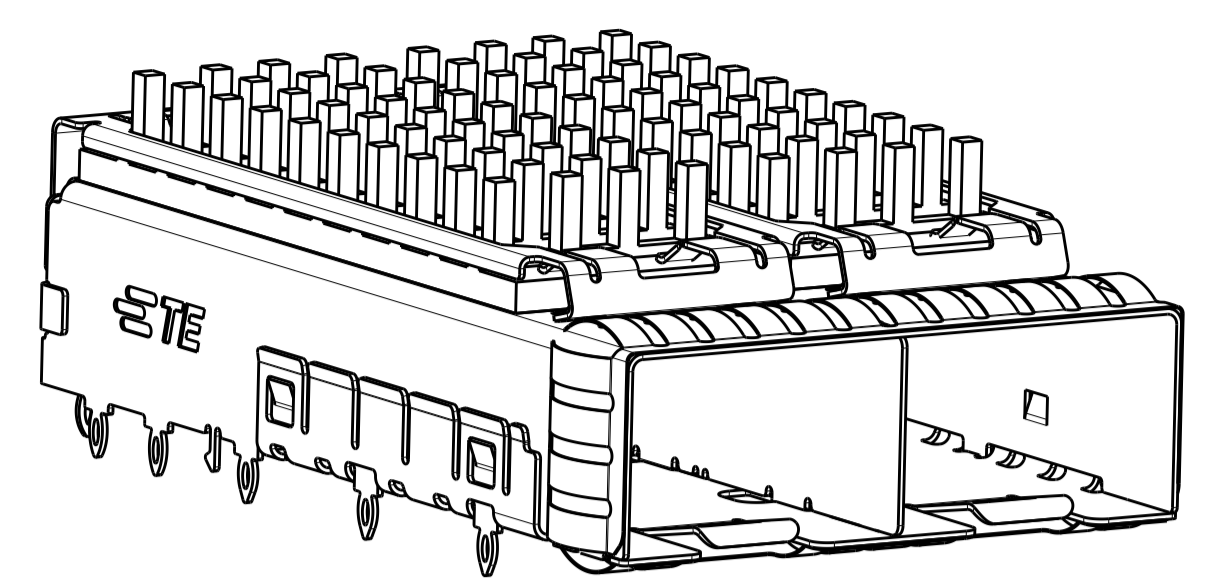

2198230-1, 2, 3, 4  
 FINISHED ASSEMBLY WITH  
 PIN TYPE HEAT SINK

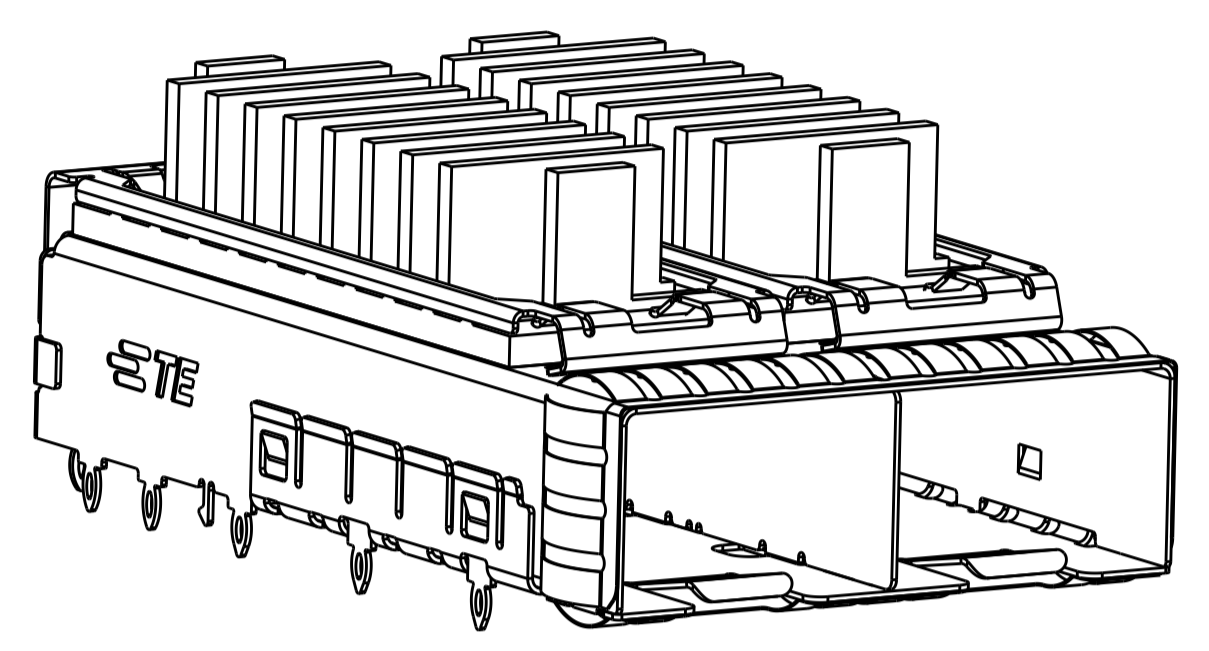

2198230-5, 6, 7, 8  
 FINISHED ASSEMBLY WITH  
 FIN TYPE HEAT SINK

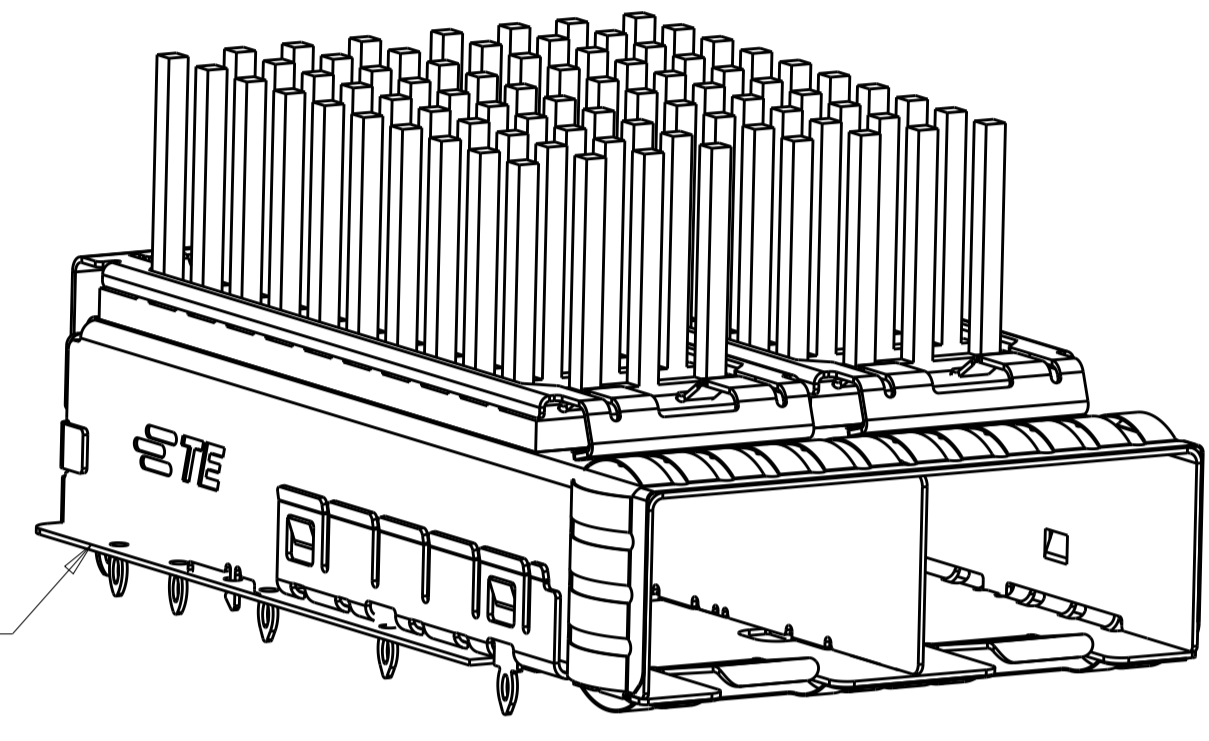

PCB GASKET

1-2198230-4  
 FINISHED ASSEMBLY WITH  
 PIN TYPE HEAT SINK, WITH BELLY GASKET

△ MATERIAL:  
 CAGE ASSEMBLY:  
 0.25mm THICK NICKEL SILVER ALLOY  
 EMI SPRINGS: COPPER ALLOY  
 HEAT SINK: ALUMINUM  
 HEAT SINK CLIP: STAINLESS STEEL.

△ FINISH:  
 HEAT SINK: ELECTROLESS NICKEL  
 HEAT SINK CLIP: PASSIVATE.  
 EMI SPRINGS: 0.8µm MIN MATTE TIN OVER  
 0.8µm MIN NICKEL, NON-PLATED EDGES PERMISSIBLE.

△ DATUM AND BASIC DIMENSIONS ESTABLISHED BY CUSTOMER.

△ PADS AND VIAS CHASSIS GROUND.

5. MATES WITH SFP MSA COMPLIANT RECIEVERS.

6. INTERPRETATION OF DATUM REFERENCE FRAME IN ACCORDANCE WITH SECT 4.4.1.1 OR ASME Y14.5M-1994.

△ MINIMUM PC BOARD THICKNESS:  
 SINGLE SIDED: 1.5mm  
 DOUBLE SIDED: 2.25mm

△ HOLE PATTERN REPEATS FOR EACH PORT, SPACING BETWEEN PORTS IS 14.25mm.

△ REFERENCE APPLICATION SPEC. 114-13120, HOLE A, FOR RECOMMENDED DRILL HOLE DIAMETER AND PLATING THICKNESS.

△ REFERENCE APPLICATION SPEC. 114-13120, HOLE B, FOR RECOMMENDED DRILL HOLE DIAMETER AND PLATING THICKNESS.

11. CERTAIN MATING TRANCEIVERS MAY REQUIRE ADDITIONAL PCB THICKNESS THAT WOULD NEED TO BE DETERMINED BY THE CUSTOMER.

12. PRODUCT COMPLIES WITH SPECIFICATION SFF-8433 IMPROVED PLUGGABLE FORM FACTOR FOR SFP+ GANGED CAGES.

△ DIMENSION APPLIES PRIOR TO INSERTION OF SFP MODULE.

△ WITH BELLY GASKET: RF ABSORBER

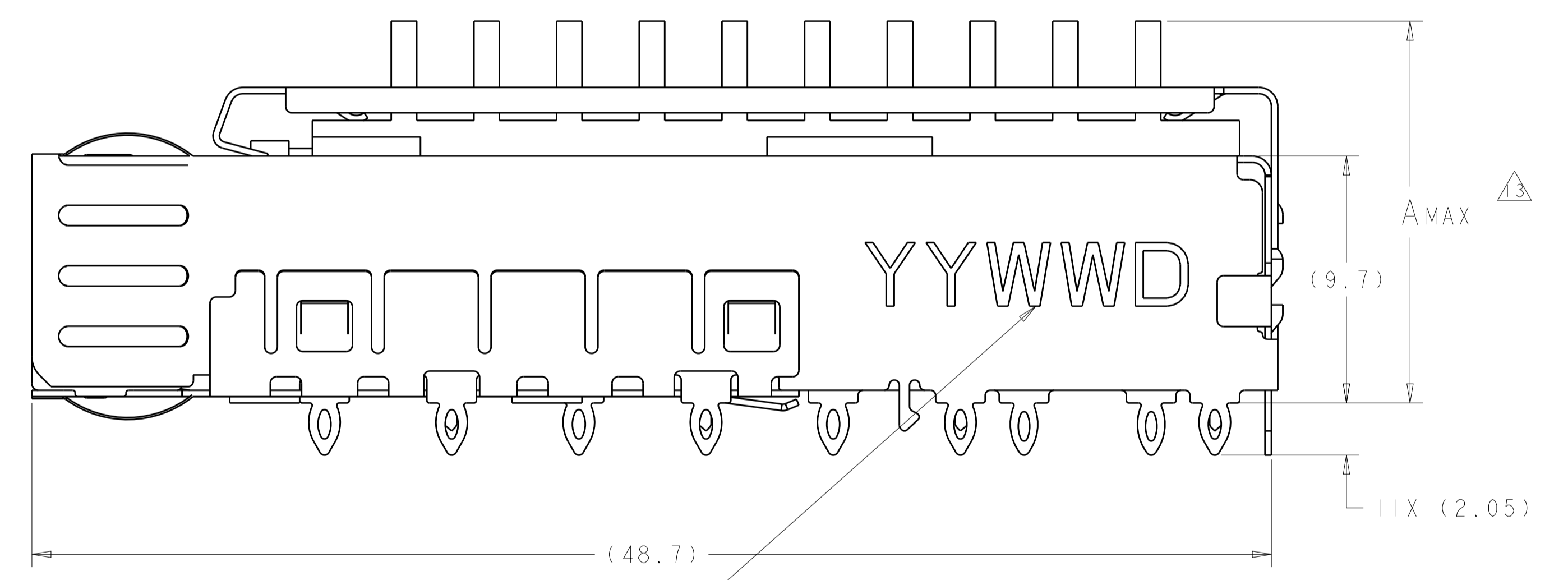
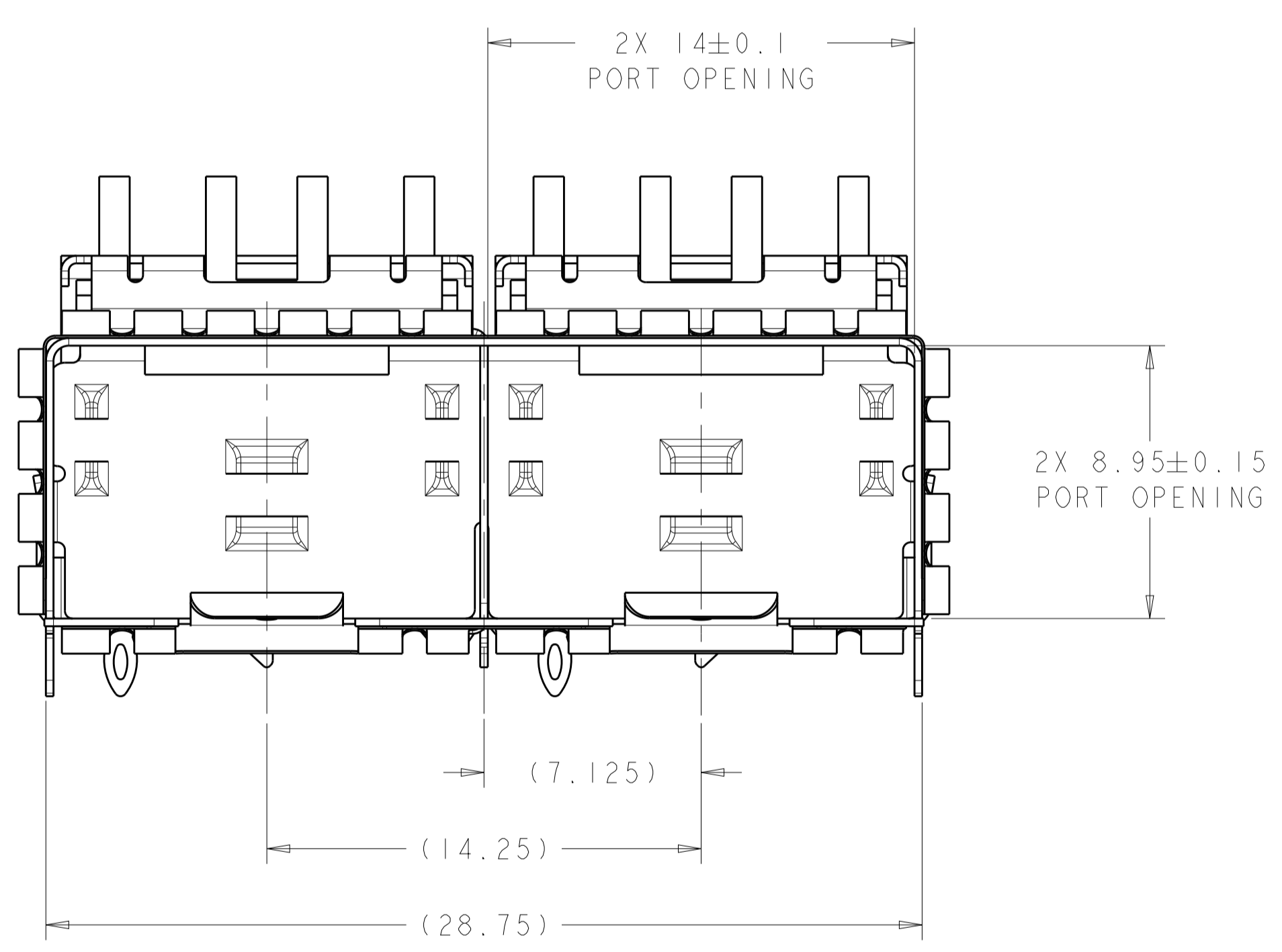

APPROXIMATE LOCATION OF DATE CODE

FIN TYPE	22.5	NETWORKING, TALL	2198230-8
FIN TYPE	18.1	NETWORKING, SHORT	2198230-7
FIN TYPE	15.5	SAN	2198230-6
FIN TYPE	13.2	PCI	2198230-5
PIN TYPE	22.5	NETWORKING, TALL	1-2198230-4
PIN TYPE	22.5	NETWORKING, TALL	2198230-4
PIN TYPE	18.1	NETWORKING, SHORT	2198230-3
PIN TYPE	15.5	SAN	2198230-2
PIN TYPE	13.2	PCI	2198230-1
HEAT SINK	A	DESCRIPTION	PART NUMBER

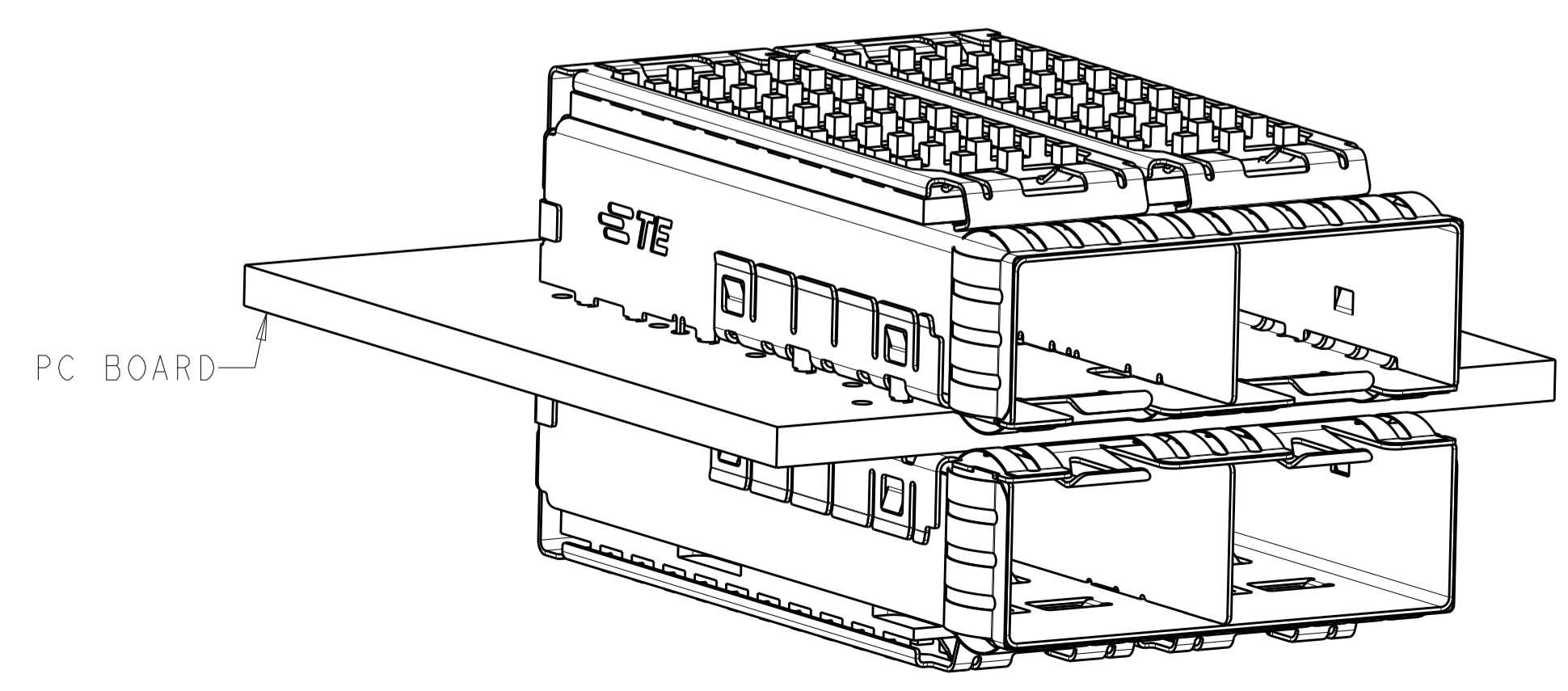

PC BOARD

2198230-1  
 MOUNTED BELLY TO BELLY  
 SCALE 3:1

THIS DRAWING IS A CONTROLLED DOCUMENT. DWN: C. VALENTINE 06OCT2011  
 CHK: M. SCHMITT 06OCT2011  
 APVD: M. SCHMITT 06OCT2011

**STE** TE Connectivity

NAME: SFP+ ENHANCED 1X2 CAGE ASSEMBLY, PRESS-FIT, EMI SPRINGS, HEAT SINK

PRODUCT SPEC: 108-2364  
 APPLICATION SPEC: 114-13120

SIZE: A1  
 CAGE CODE: 00779  
 DRAWING NO: C=2198230

RESTRICTED TO: -

Customer Drawing SCALE: 2:1 SHEET: 1 OF 4 REV: B

LOC		DIST		REVISIONS			
GP	00	P	LTN	DESCRIPTION	DATE	DMN	APVD
		-		SEE SHEET 1	-	-	-

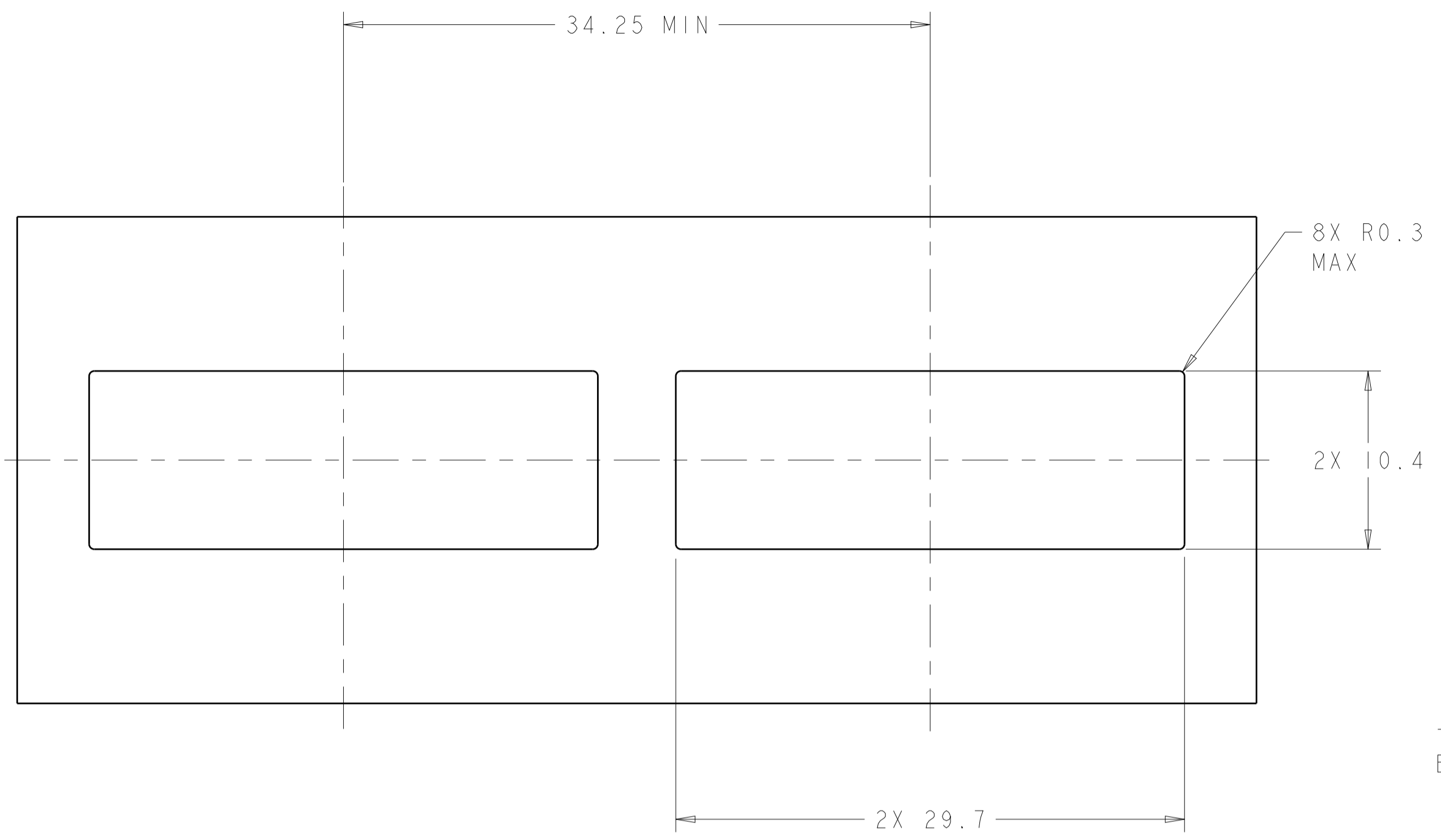

RECOMMENDED BEZEL CUT-OUT  
 SINGLE SIDED APPLICATIONS  
 SCALE 4:1

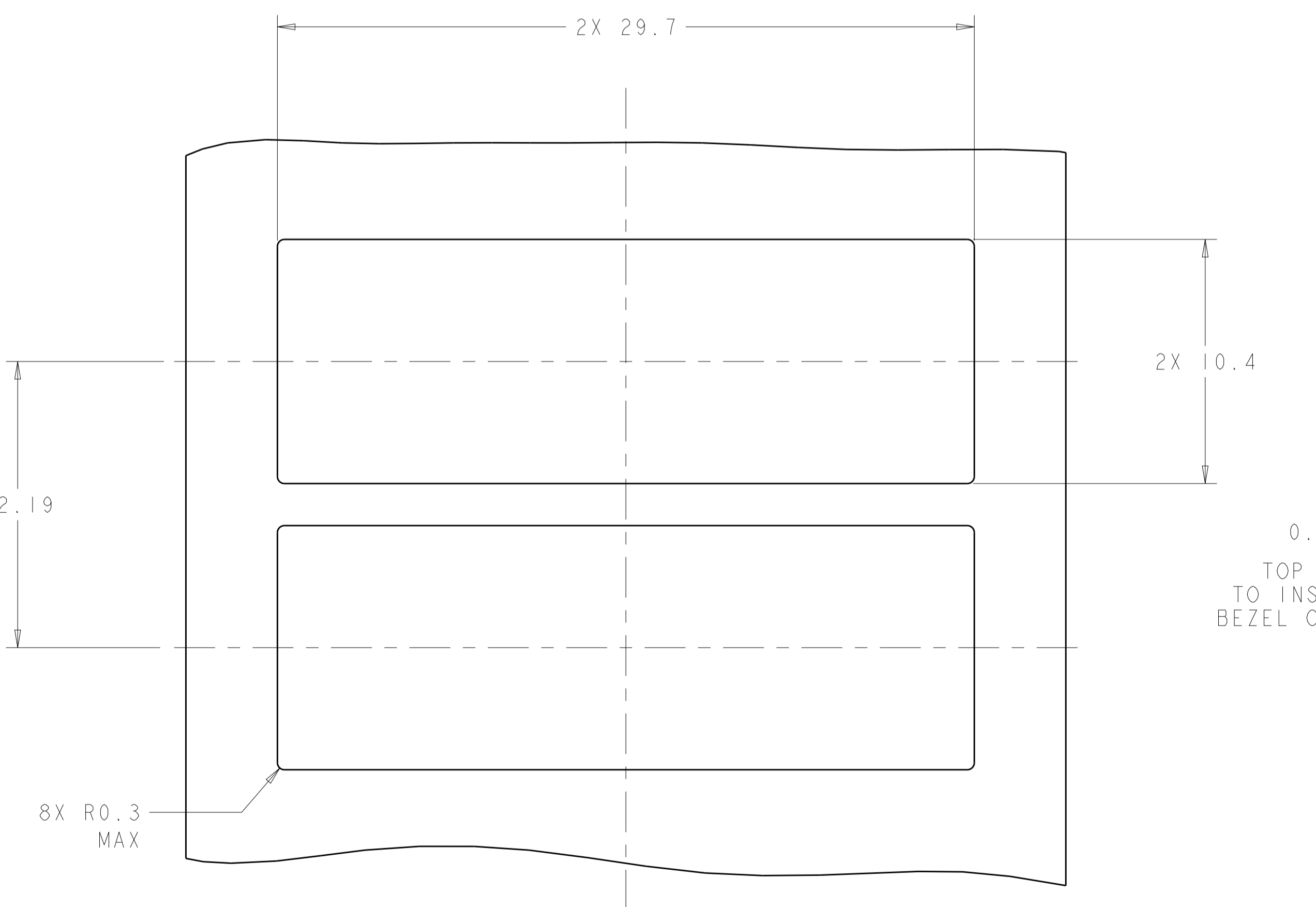

RECOMMENDED BEZEL CUT-OUT  
 BELLY TO BELLY APPLICATIONS

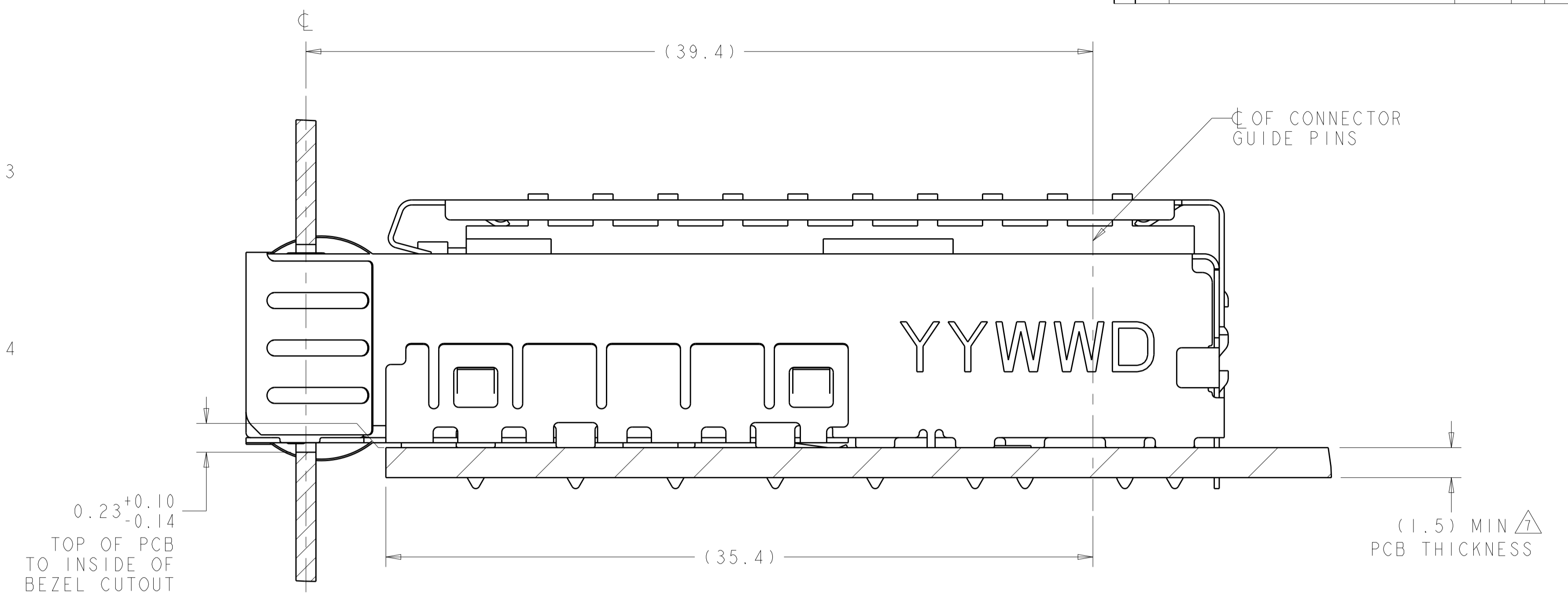

2198230-1  
 MOUNTED ON PC BOARD  
 SHOWN THRU RECOMMENDED BEZEL

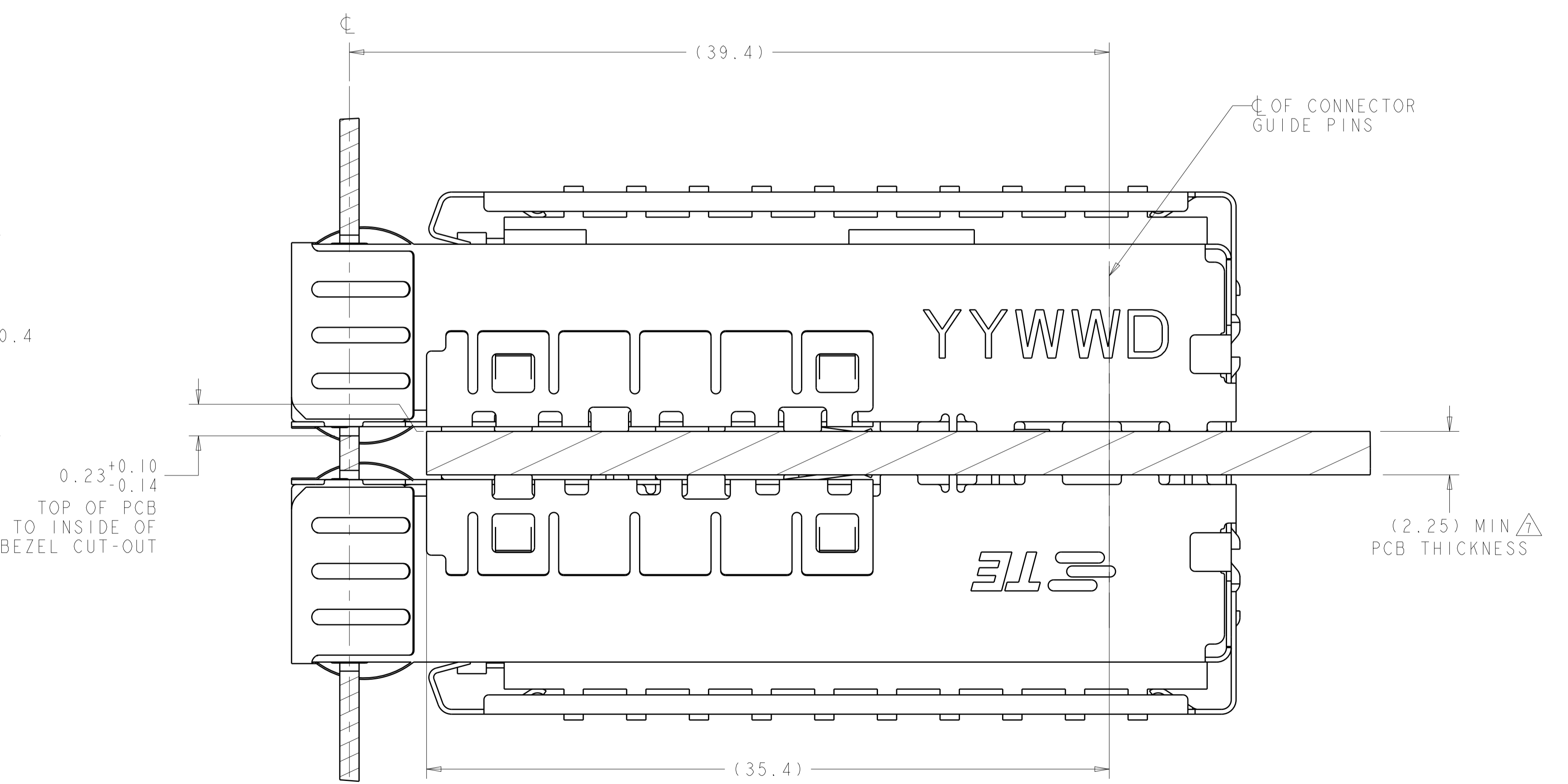

2198230-1  
 MOUNTED BELLY TO BELLY ON PC BOARD  
 SHOWN THRU RECOMMENDED BEZEL

THIS DRAWING IS A CONTROLLED DOCUMENT.		DMN C. VALENTINE 06OCT2011	TE Connectivity NAME SFP+ ENHANCED 1X2 CAGE ASSEMBLY, PRESS-FIT, EMI SPRINGS, HEAT SINK
DIMENSIONS:		CHK M. SCHMITT 06OCT2011	
TOLERANCES UNLESS OTHERWISE SPECIFIED:		APVD M. SCHMITT 06OCT2011	SIZE CAGE CODE DRAWING NO
mm	0 PLC ±0.13	PRODUCT SPEC	RESTRICTED TO
	1 PLC ±0.1	108-2364	A100779
	2 PLC ±0.08	APPLICATION SPEC	SCALE 6:1 SHEET 2 OF 4 REV B
	3 PLC ±0.05	114-13120	
	4 PLC ±0.05	WEIGHT	
	ANGLES		
	FINISH		
MATERIAL		Customer Drawing	

LOC	DIST	REVISIONS			
GP	00	REV	DATE	BY	APPV
		1	SEE SHEET 1		

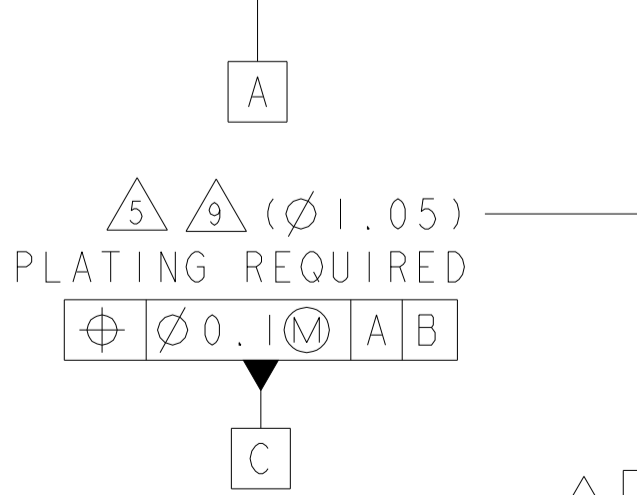
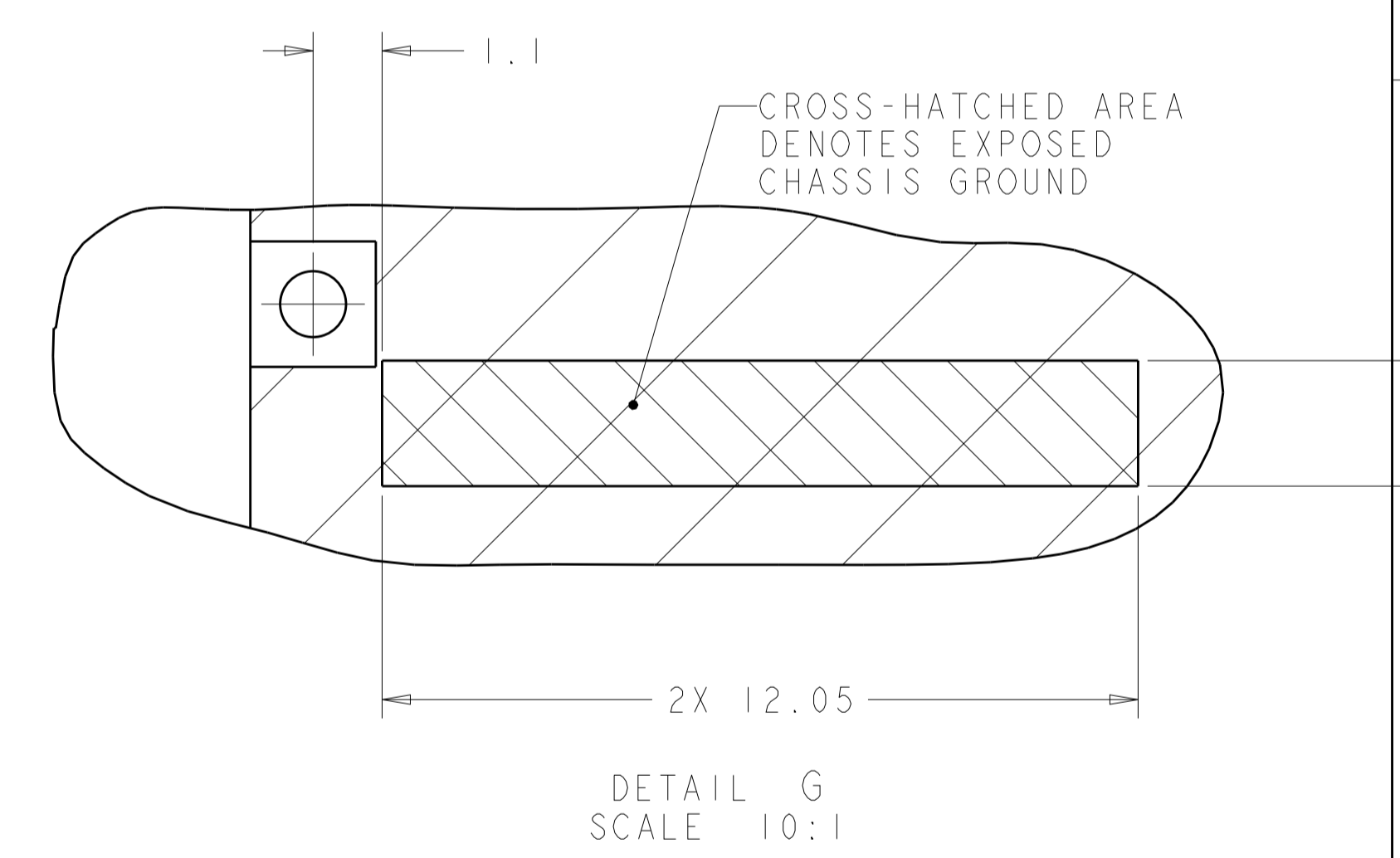
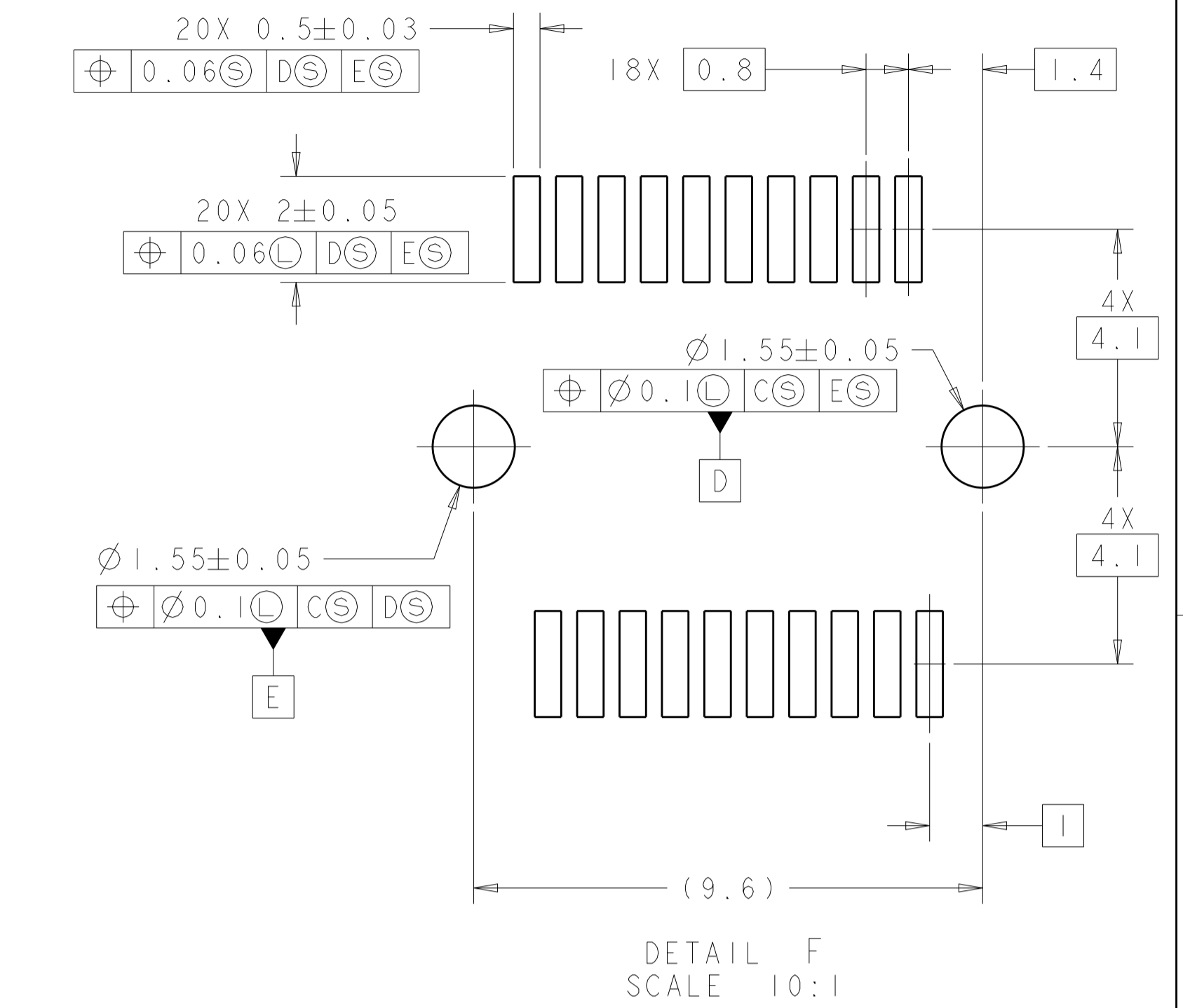
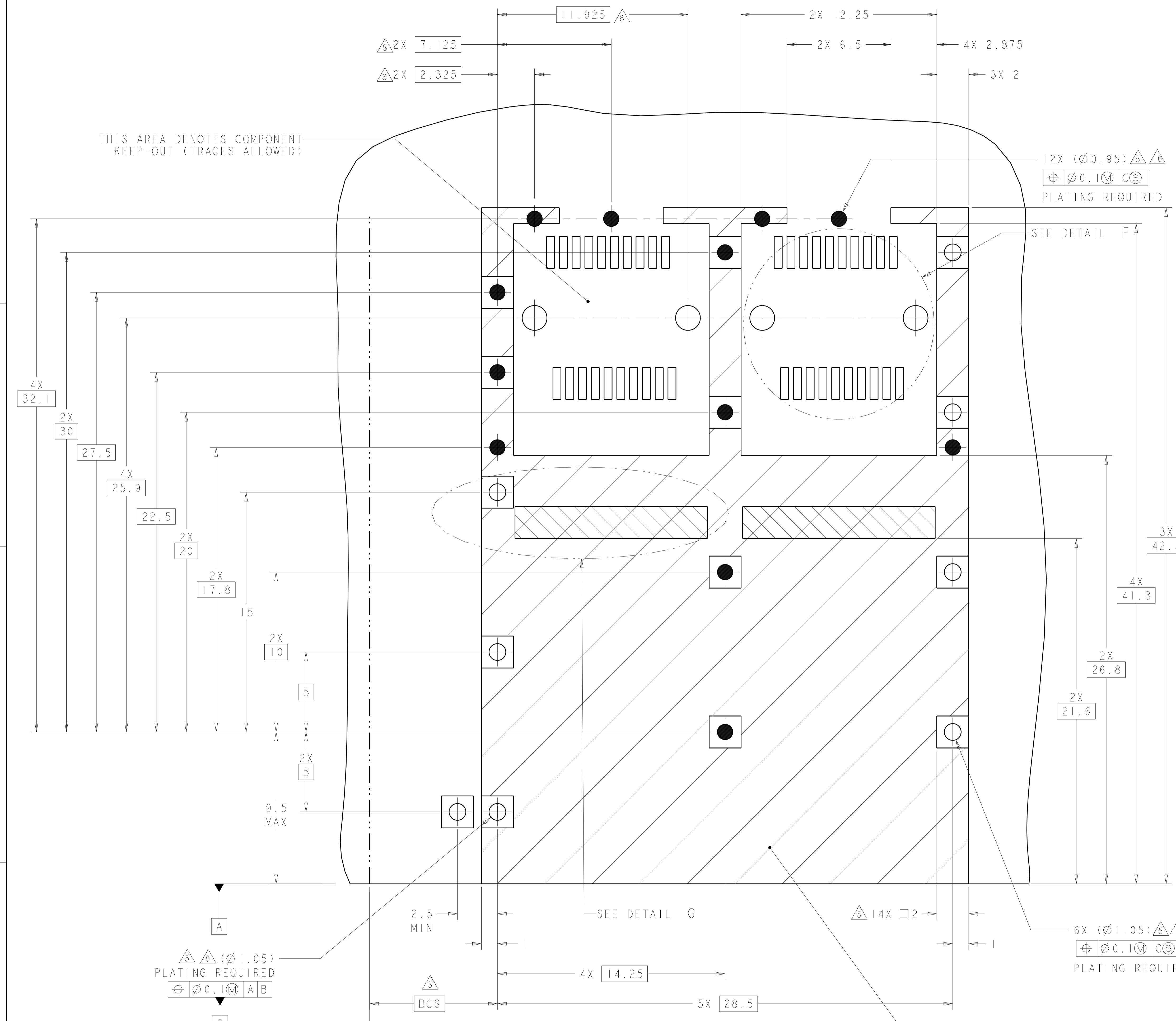

RECOMMENDED PCB CONFIGURATION WITH KEEP-OUT AREAS SINGLE SIDED APPLICATIONS SCALE 8:1

CROSS-HATCHED AREA DENOTES COMPONENT AND TRACE KEEP-OUT (EXCEPT CHASSIS GROUND)

THIS DRAWING IS A CONTROLLED DOCUMENT.		OWN: C. VALENTINE 06OCT2011	TE Connectivity
DIMENSIONS: mm		CHK: M. SCHMITT 06OCT2011	
TOLERANCES UNLESS OTHERWISE SPECIFIED:		APVD: M. SCHMITT 06OCT2011	NAME: SFP+ ENHANCED 1X2 CAGE ASSEMBLY, PRESS-FIT, EMI SPRINGS, HEAT SINK PRODUCT SPEC: 108-2364 APPLICATION SPEC: 114-13120
0 PLC ±0.13 1 PLC ±0.1 2 PLC ±0.08 3 PLC ±0.05 4 PLC ±0.05 ANGLES ±0.5		SIZE: CAGE CODE DRAWING NO: A100779C=2198230 WEIGHT: - Customer Drawing	
MATERIAL: FINISH: #1		RESTRICTED TO: -	SCALE: 6:1 SHEET 3 OF 4 REV B

LOC	DIST	REV	DATE	APPV
GP	00			

REVISIONS				
REV	DATE	APPV	DESCRIPTION	DATE
-	-	-	SEE SHEET 1	-

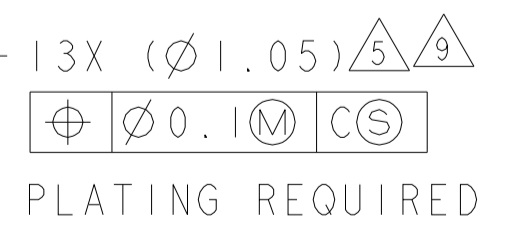
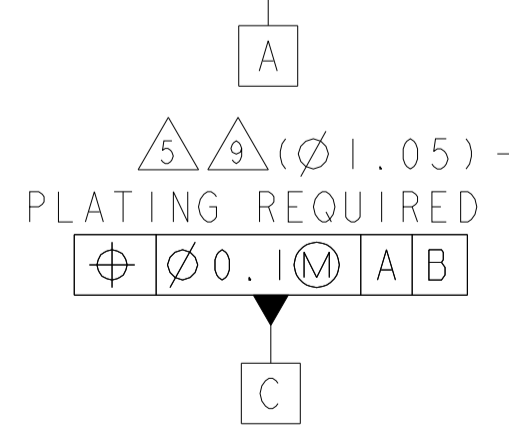
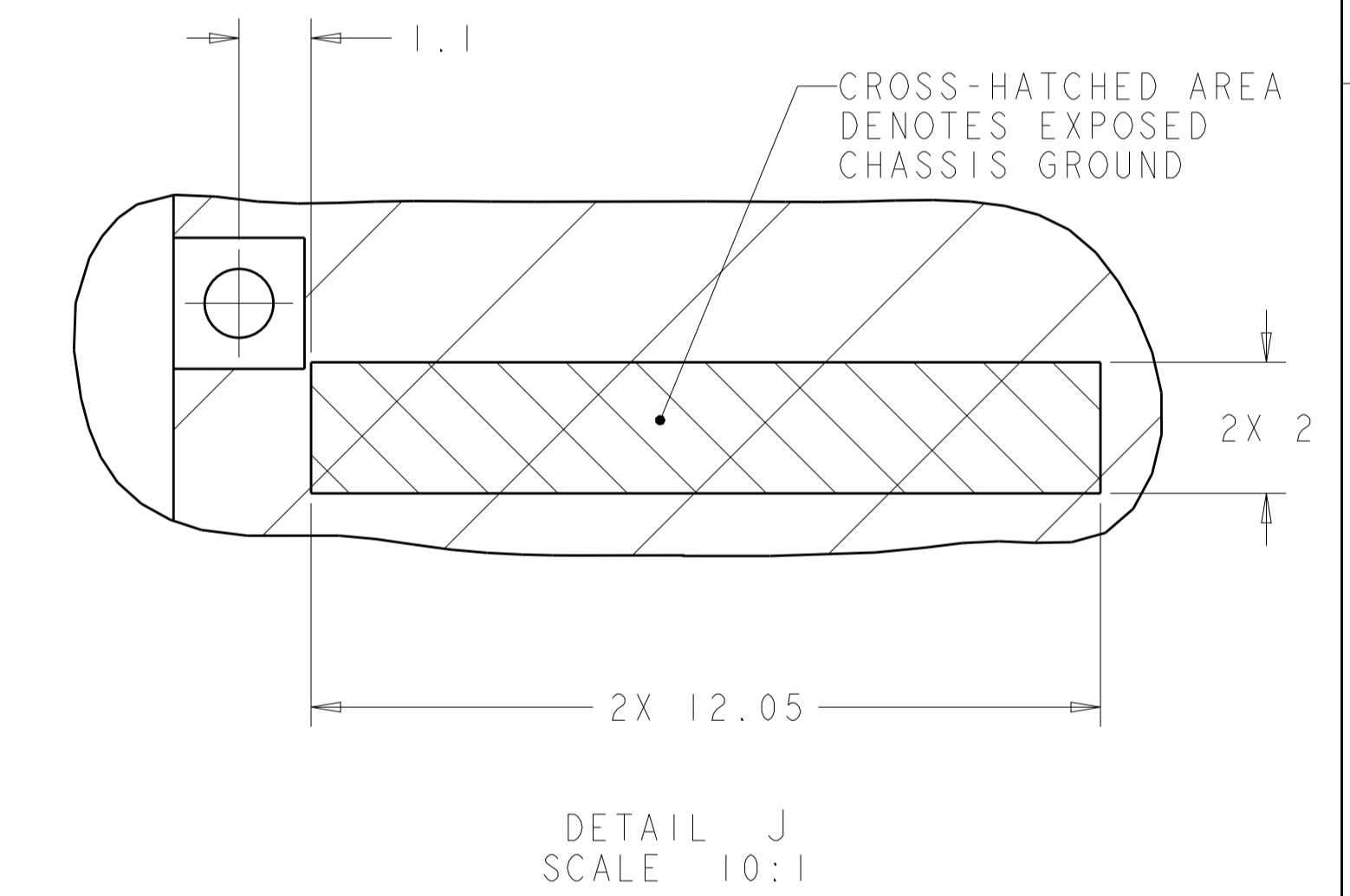
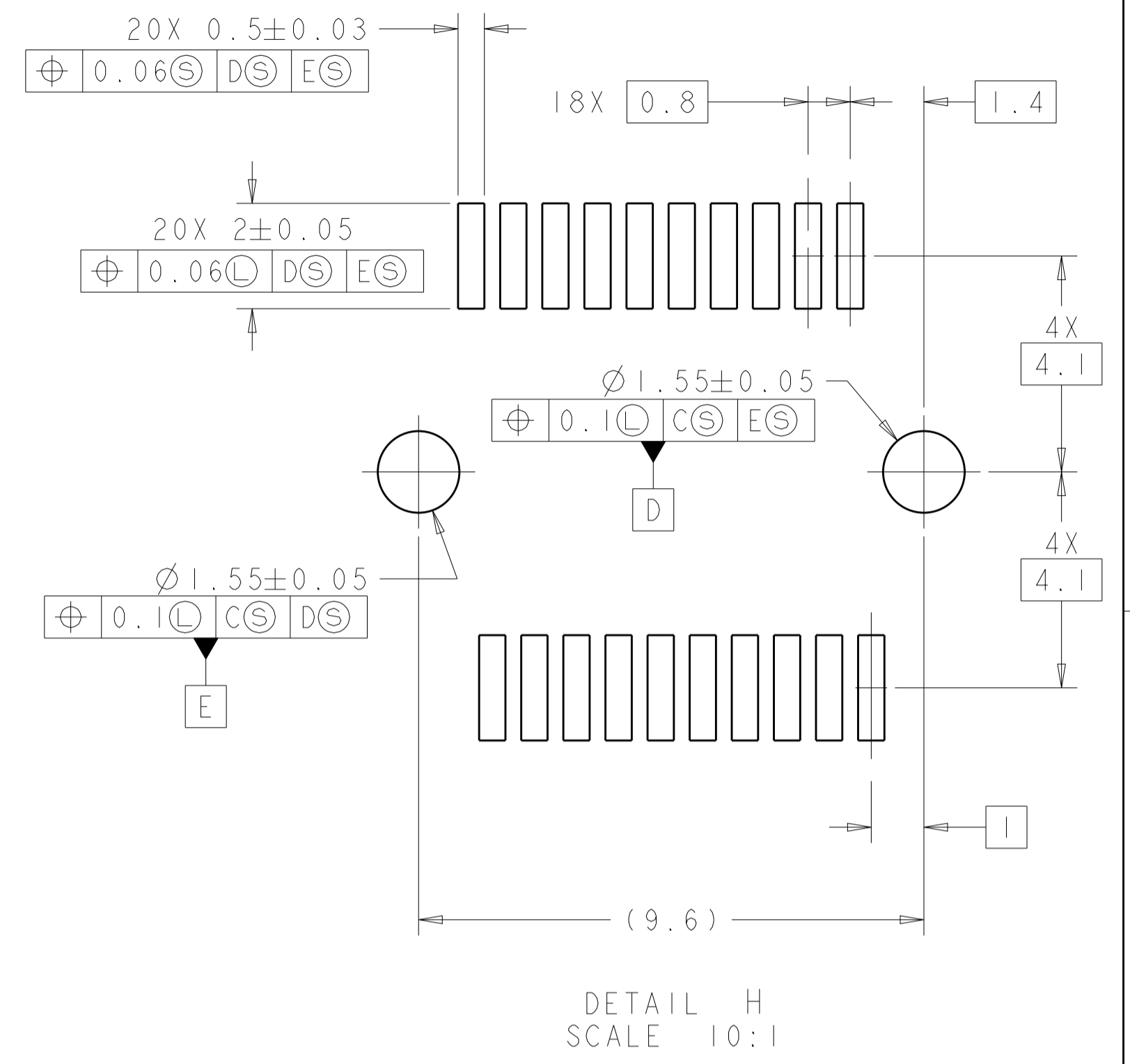
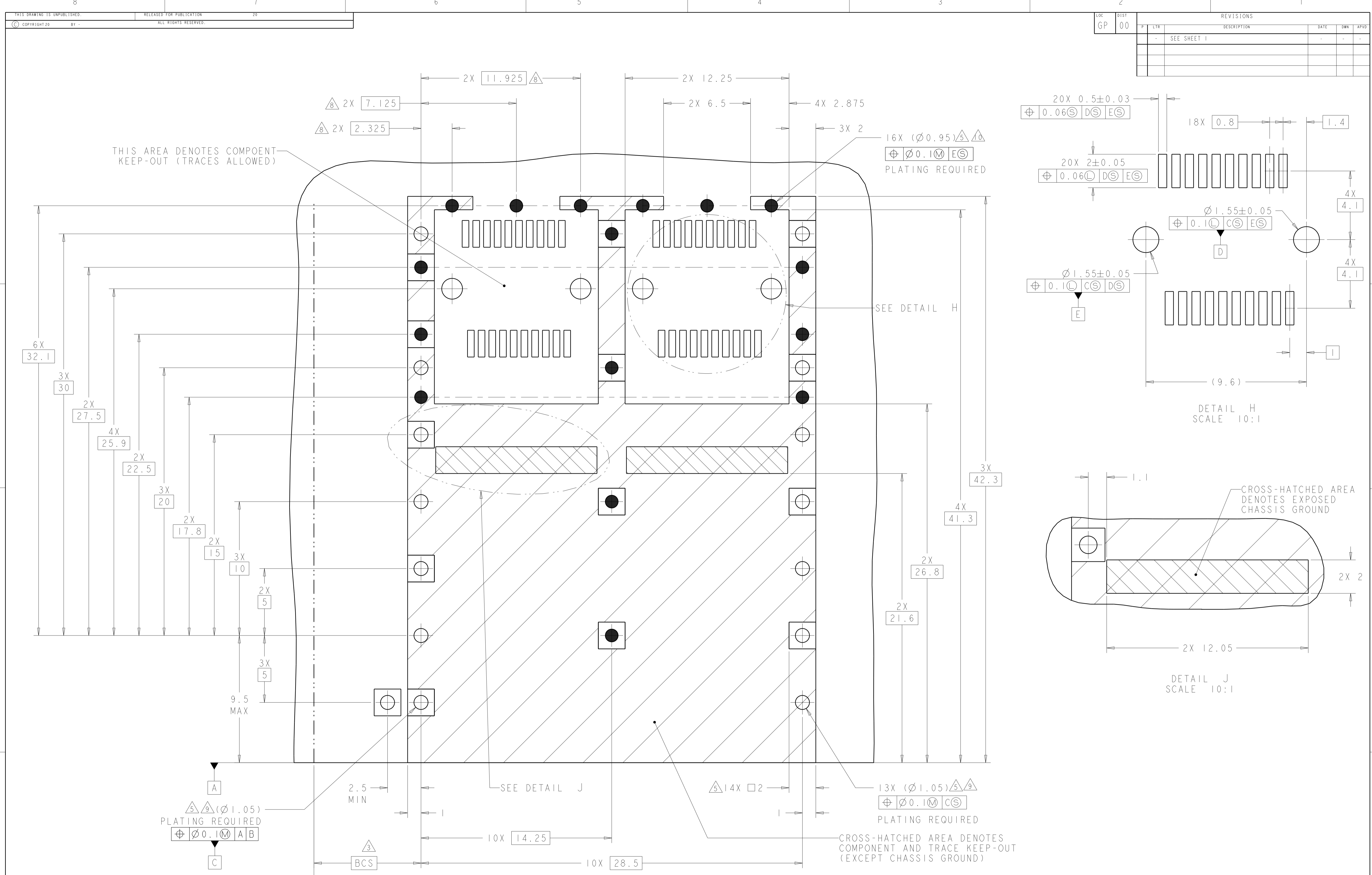

RECOMMENDED PCB CONFIGURATION WITH KEEP-OUT AREAS BELLY TO BELLY APPLICATIONS SCALE 8:1

THIS DRAWING IS A CONTROLLED DOCUMENT.		OWN: C. VALENTINE 06OCT2011	TE Connectivity
DIMENSIONS: mm		CHK: M. SCHMITT 06OCT2011	
TOLERANCES UNLESS OTHERWISE SPECIFIED:		APVD: M. SCHMITT 06OCT2011	NAME: SFP+ ENHANCED 1X2 CAGE ASSEMBLY, PRESS-FIT, EMI SPRINGS, HEAT SINK PRODUCT SPEC: 108-2364 APPLICATION SPEC: 114-13120 WEIGHT: - SIZE: CAGE CODE DRAWING NO: A100779 RESTRICTED TO: -
0 PLC ±0.13		PRODUCT SPEC: 108-2364	
1 PLC ±0.1		APPLICATION SPEC: 114-13120	
2 PLC ±0.08		WEIGHT: -	
3 PLC ±0.05		SIZE: CAGE CODE DRAWING NO: A100779	SCALE: 6:1
4 PLC ±0.05		RESTRICTED TO: -	SHEET: 4 OF 4
ANGLES ±0.1		Customer Drawing	REV: B

## X-ON Electronics

Largest Supplier of Electrical and Electronic Components

*Click to view similar products for [I/O Connectors](#) category:*

*Click to view products by [TE Connectivity](#) manufacturer:*

Other Similar products are found below :

[571763P](#) [58098-0628](#) [D20419-211](#) [D38999/20FJ24PA L/C](#) [D38999/20FJ29SB L/C](#) [D38999/24FG11SN L/C](#) [72.250.1628.2](#) [72.250.2428.2](#)  
[74720-0505](#) [76.350.0729.0](#) [76871-1403](#) [FCN-244F080-G/1](#) [FCN-260A9920](#) [FCN-268D024-G/2F#10X-R10](#) [PCS-E50FA](#) [PCS-XE26LKA](#)  
[PCS-XE26MA+](#) [PCS-XES68MS+](#) [G38A71314B](#) [DX40-50P\(55\)](#) [1571250010](#) [157-22500-3](#) [MS3471L14-19P L/C](#) [1888020-8](#) [91-569786-](#)  
[35H](#) [91-569786-35M](#) [91-644626-35P](#) [SM3100F14S-58S](#) [172501-4002](#) [172501-6002](#) [FCN-260C008-A/L0](#) [FCN-260C024-AL0](#) [FCN-](#)  
[261Z008](#) [FCN-268D008-G/1K](#) [2000314-1](#) [200331-1](#) [2007498-2](#) [PCR-E28LMDAG1+](#) [PCR-E36FC+](#) [PCS-E28FS+](#) [PCS-XE26SLFD+](#) [PCS-](#)  
[XE26SLFDT+](#) [G38A71214B](#) [HDRA-E68W1LFDTC-SL+](#) [HDR-E14MSG1+](#) [R88A-CNK81S](#) [CRT1-ATT02](#) [54182-0605](#) [U90B2054081210](#)  
[UE86K842720321](#)