

THIS DRAWING IS UNPUBLISHED. RELEASED FOR PUBLICATION SEP ,2007.
 © COPYRIGHT 2007 By - ALL RIGHTS RESERVED.

LOC	DIST	REVISIONS			
P	LTR	DESCRIPTION	DATE	DWN	APVD
J	/				
	C	REVISED PER ECR-12-004002	01MAR2012	W.W	C.W

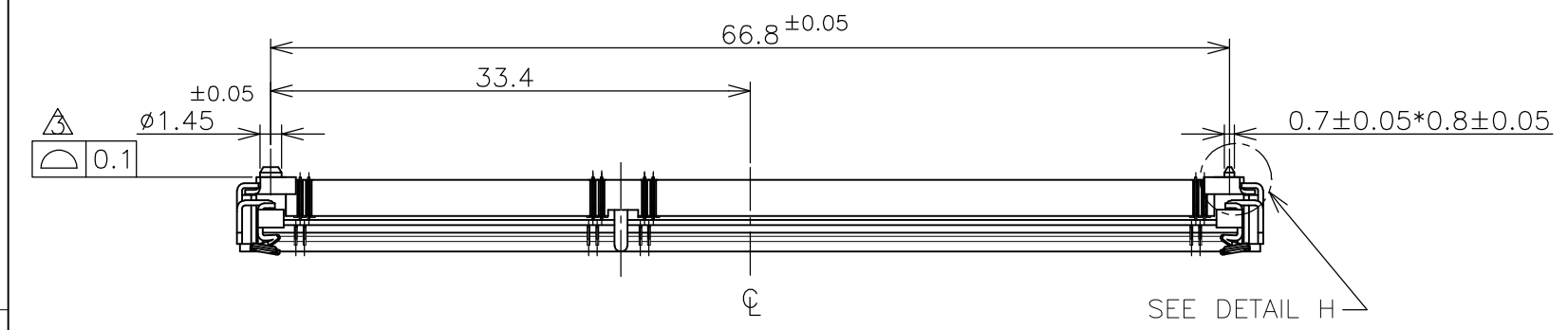

HOW TO MATE AND UNMATE

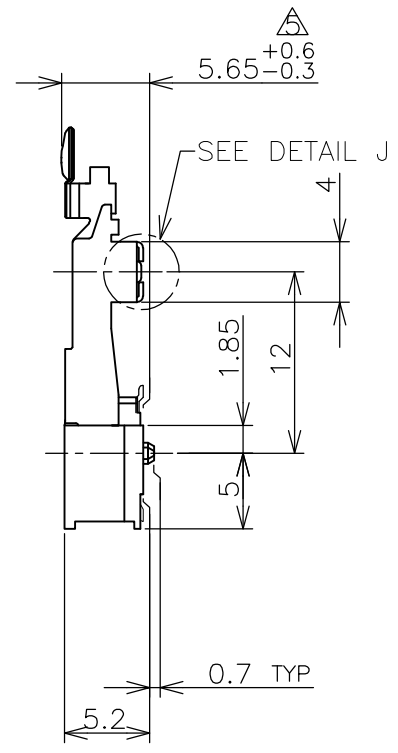
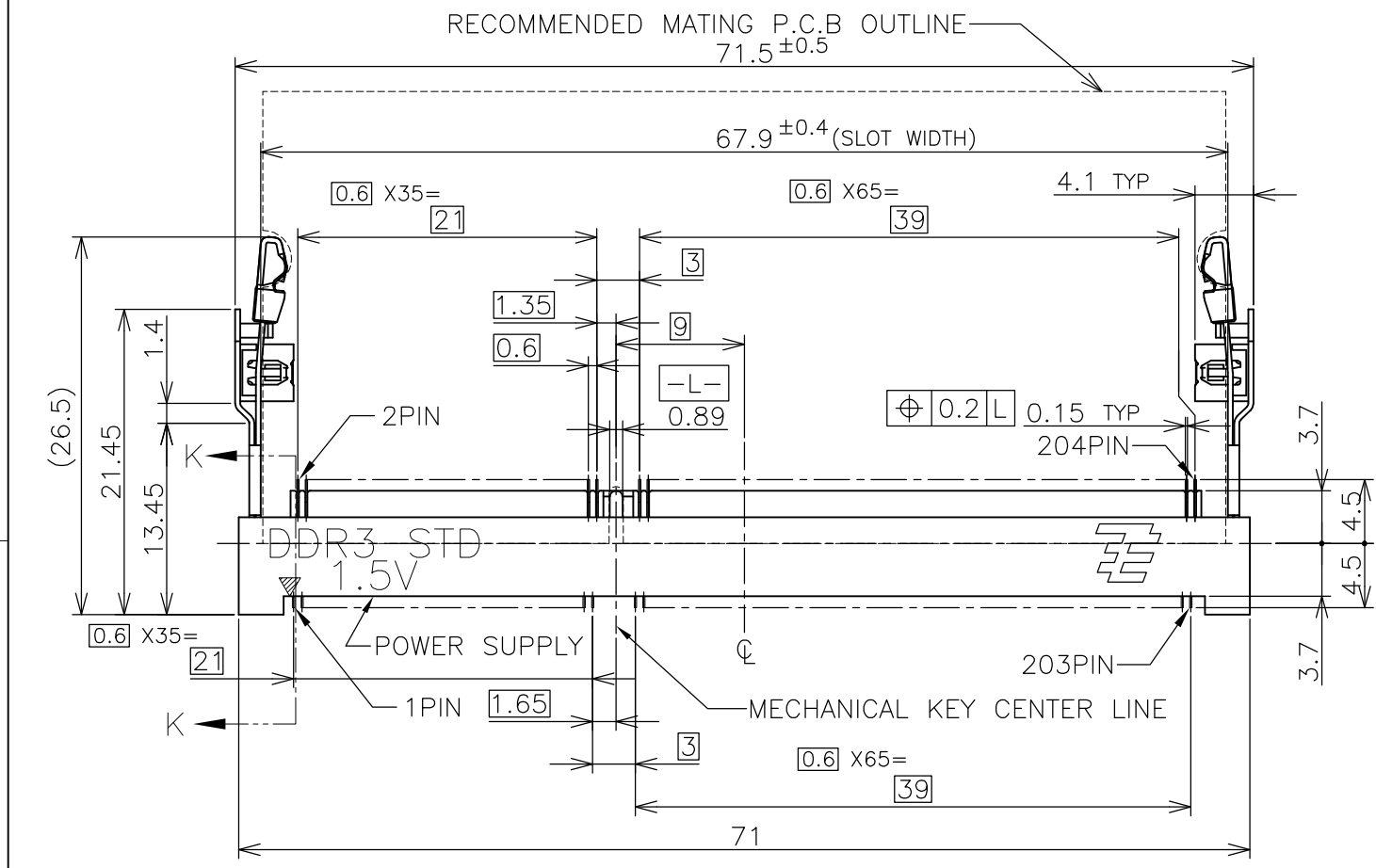
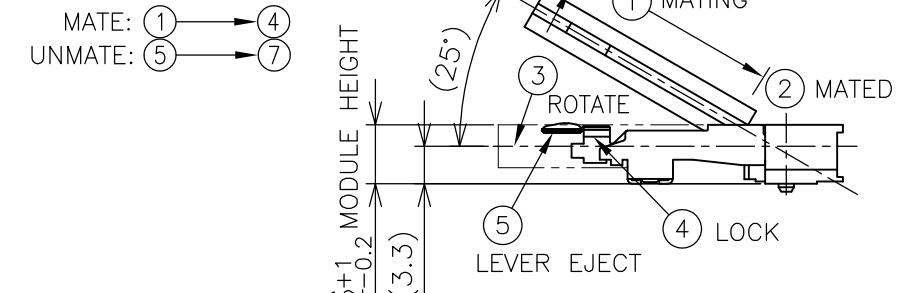

- (APPLIED TO SHEET 1-3)
- MATERIAL ; HOUSING: HIGH TEMPERATURE THERMO PLASTIC UL94V-0
 COLOR: BLACK
 CONTACT: COPPER ARROY
 LOCK LEVER: STAINLESS STEEL
 PEG: COPPER ARROY
 - 2-1. FINISH ; CONTACT AREA: GOLD FLASH ALL OVER NICKEL.
 SOLDERING AREA: GOLD FLASH PLATING
 PEG: TIN PLATING
 - 2-2. FINISH ; CONTACT AREA: 0.000254MIN GOLD ALL OVER NICKEL.
 SOLDERING AREA: GOLD FLASH PLATING
 PEG: TIN PLATING
 - 2-3. FINISH ; CONTACT AREA: 0.00076MIN GOLD ALL OVER NICKEL.
 SOLDERING AREA: GOLD FLASH PLATING
 PEG: TIN PLATING
- △ COPLANARITY: 0.1 MAX. (BEFORE SOLDERING)
 △ THE FLOATING VALUE BY SOLDERING IS NOT INCLUDED.
 △ NOT MATING CONDITION.
6. IF THE MODULE DOESN'T INSERT AND LOCK IN THE LATCH SMOOTHLY, OPEN WIDE BOTH LATCHES BY MANUAL. AND THE MODULE MUST BE INSERTED AND LOCKED IN THE LATCH.

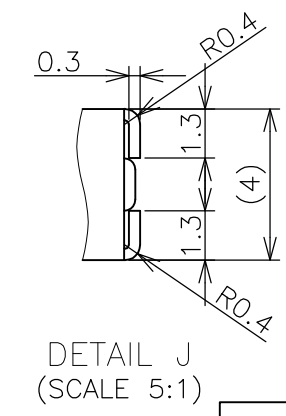
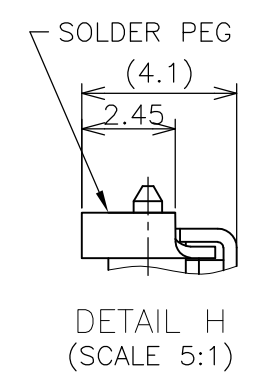
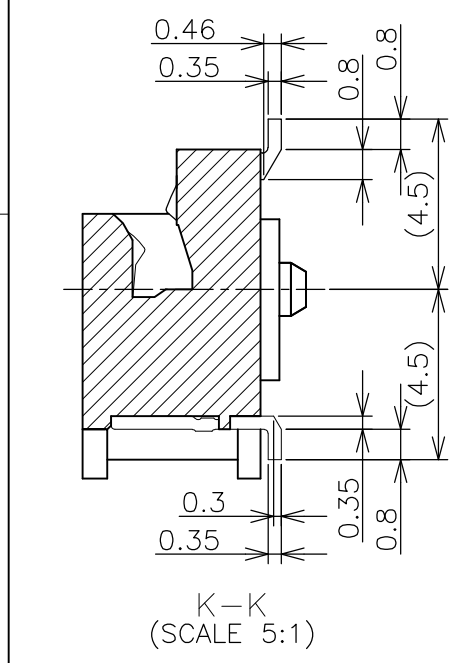

GENERAL TOLERANCE
 10 ≥ : ±0.2
 30 ≥ > 10 : ±0.25
 100 ≥ > 30 : ±0.3
 ANGLES : ±3°

THIS DRAWING IS A CONTROLLED DOCUMENT.		DWN T.FUMIKURA 18SEP2007	TE Connectivity		
DIMENSIONS: MM		CHK K.IKEGAMI 18SEP2007			
TOLERANCES UNLESS OTHERWISE SPECIFIED:		APVD K.IKEGAMI 18SEP2007	NAME		
0 PLC ±		108-78493			
1 PLC ±		APPLICATION SPEC			
2 PLC ±		SIZE CAGE CODE DRAWING NO RESTRICTED TO			
3 PLC ±		A3 00779 C-2013289			
4 PLC ±		WEIGHT 4.4g			
ANGLES ±		SCALE 2:1 SHEET 1 OF 6 REV C			
FINISH		CUSTOMER DRAWING			

THIS DRAWING IS UNPUBLISHED. RELEASED FOR PUBLICATION SEP ,2007.
 © COPYRIGHT 2007 By - ALL RIGHTS RESERVED.

LOC		DIST		REVISIONS				
P	LTR	DESCRIPTION			DATE	DWN	APVD	
	-	SEE SHEET 1			-	-	-	

TOOLING STATUS	PACKAGING TYPE	BOSS TYPE	HOUSING COLOR	FINISH	POWER SUPPLY	POS	PART NO.
AVAILABLE	ENBOSS (SEE SHEET 6)	WITH BOSS	BLACK	NOTE 2-3	1.5V	204	2-2013289-3
AVAILABLE	ENBOSS (SEE SHEET 6)	WITH BOSS	BLACK	NOTE 2-2	1.5V	204	2-2013289-2
AVAILABLE	ENBOSS (SEE SHEET 6)	WITH BOSS	BLACK	NOTE 2-1	1.5V	204	2-2013289-1
AVAILABLE	SEMI-HARD TRAY (SEE SHEET 5)	WITH BOSS	BLACK	NOTE 2-3	1.5V	204	2013289-3
AVAILABLE	SEMI-HARD TRAY (SEE SHEET 5)	WITH BOSS	BLACK	NOTE 2-2	1.5V	204	2013289-2
AVAILABLE	SEMI-HARD TRAY (SEE SHEET 5)	WITH BOSS	BLACK	NOTE 2-1	1.5V	204	2013289-1

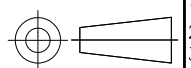
THIS DRAWING IS A CONTROLLED DOCUMENT.		DWN		 TE Connectivity					
DIMENSIONS: MM		CHK							
		TOLERANCES UNLESS OTHERWISE SPECIFIED:		NAME					
		0 PLC ± 1 PLC ± 2 PLC ± 3 PLC ± 4 PLC ± ANGLES ±		APVD		DDR3 SODIMM SOCKET 0.6mm PITCH 204POS 5.2mm HEIGHT STANDARD TYPE			
MATERIAL		FINISH		PRODUCT SPEC		DRAWING NO		RESTRICTED TO	
				APPLICATION SPEC		A300779		C-2013289	
				WEIGHT		SCALE 2:1		SHEET 2 of 6	
				CUSTOMER DRAWING		REV C			

THIS DRAWING IS UNPUBLISHED.

RELEASED FOR PUBLICATION SEP .2007.

© COPYRIGHT 2007 By -

ALL RIGHTS RESERVED.

LOC J DIST

REVISIONS

P	LTR	DESCRIPTION	DATE	DWN	APVD
-	-	SEE SHEET 1	-	-	-

REFERENCE P.C.BOARD PATTERN LAYOUT (CONNECTOR MOUNTING SIDE)

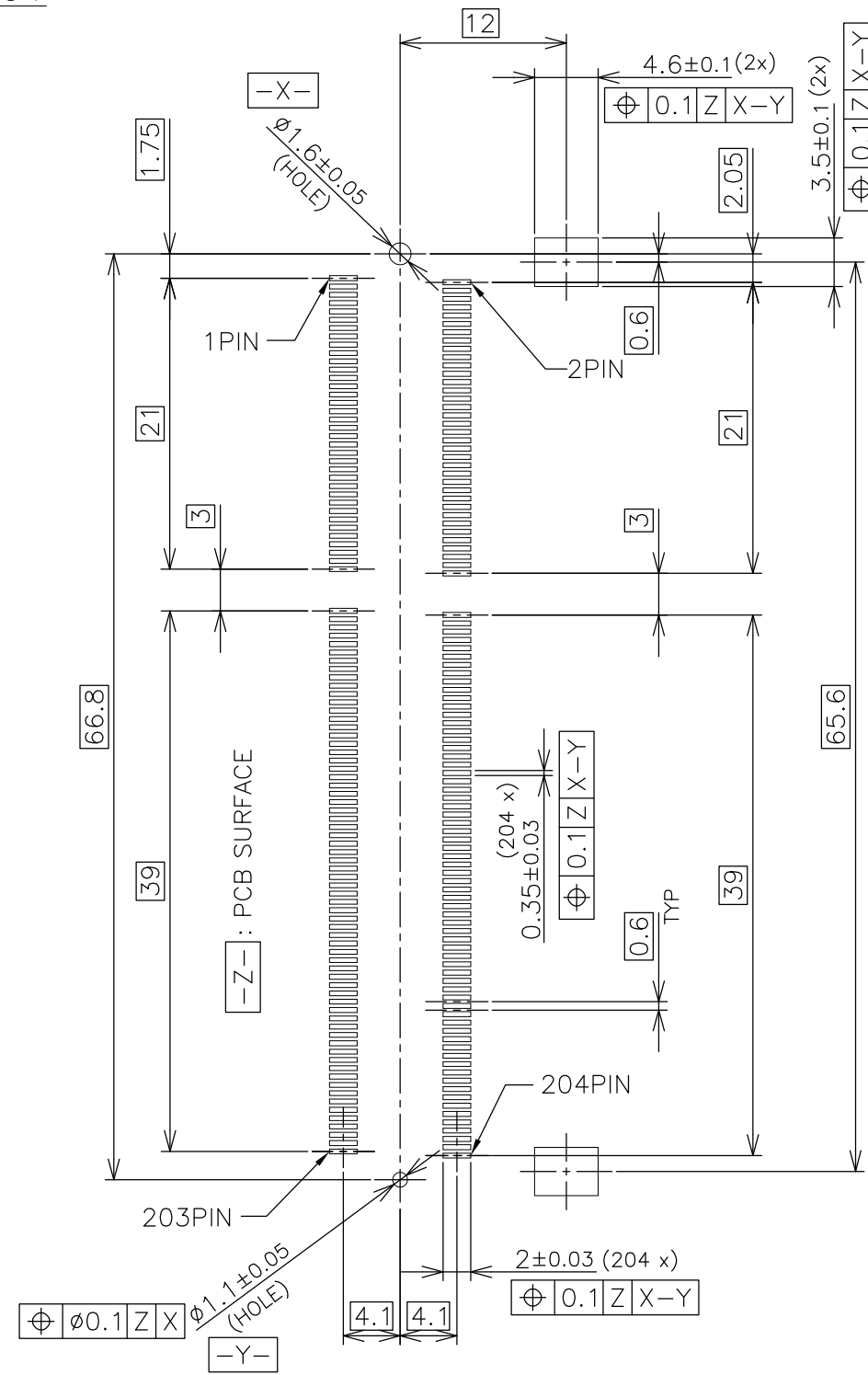

STD TYPE

THIS DRAWING IS A CONTROLLED DOCUMENT.		DWN		TE Connectivity	
DIMENSIONS: MM		CHK			
		TOLERANCES UNLESS OTHERWISE SPECIFIED:		NAME	
MATERIAL		FINISH		DDR3 SODIMM SOCKET 0.6mm PITCH 204POS 5.2mm HEIGHT STANDARD TYPE	
APVD		PRODUCT SPEC		SIZE	CAGE CODE
APVD		APPLICATION SPEC		DRAWING NO	RESTRICTED TO
WEIGHT		CUSTOMER DRAWING		A300779	C-2013289
SCALE 2:1		SHEET 3 of 6		REV C	

LOC	DIST	REVISIONS					
		P	LTR	DESCRIPTION	DATE	DWN	APVD
J	/	-	-	SEE SHEET 1	-	-	-

REFERENCE MATING P.C.B CONFIGURATION

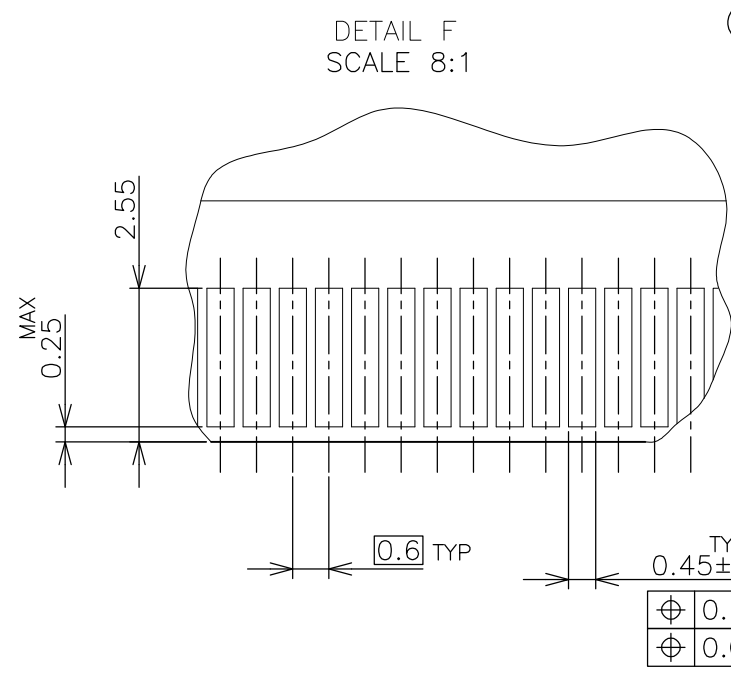
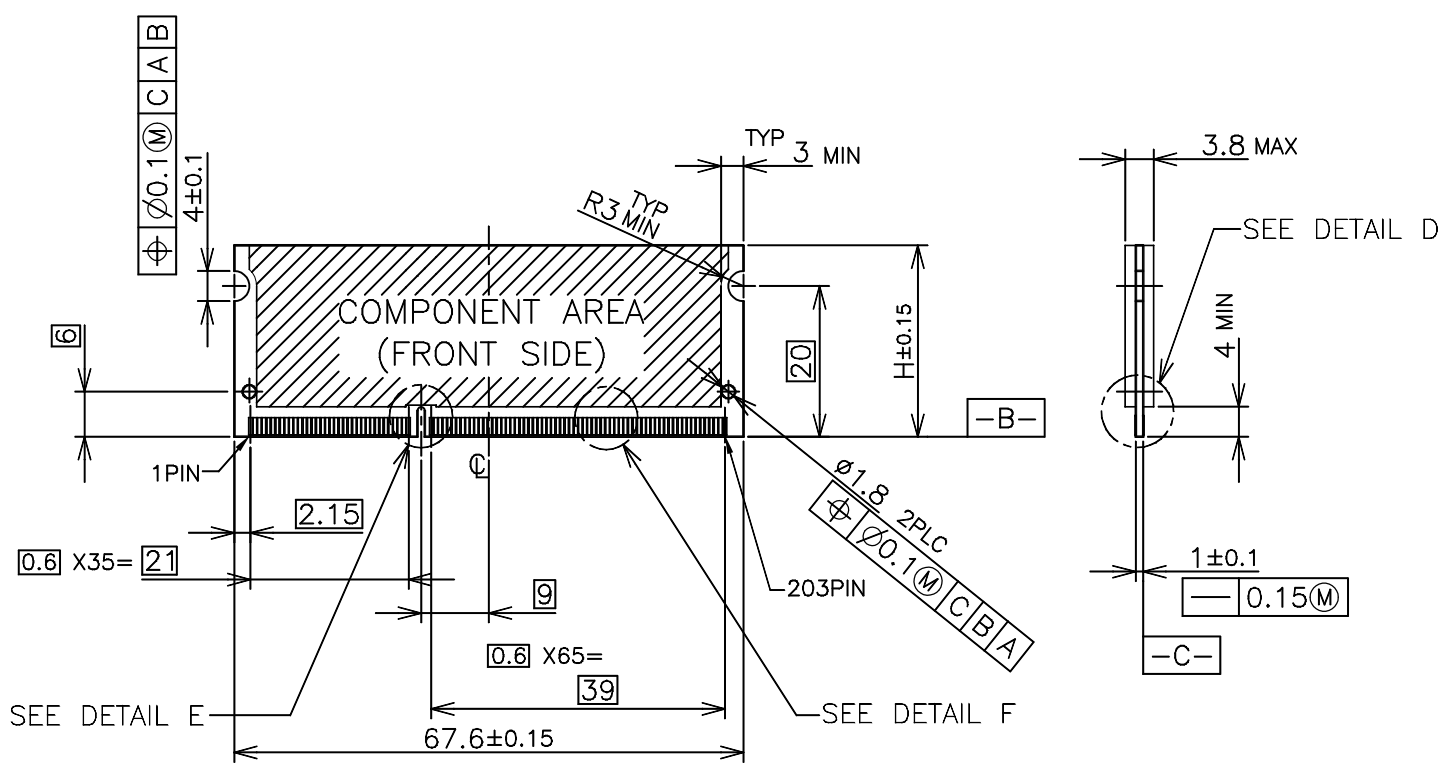

- (APPLIED TO SHEET 4)
1. TOLERANCES ON ALL DIMENSIONS ±0.15 UNLESS OTHERWISE SPECIFIED.
 2. P.C. BOARD THICKNESS APPLIES ACROSS TABS AND INCLUDES PLATING AND/OR METALIZATION.
 3. FINISH OF PAD : GOLD PLATING 0.00076 MIN. OVER Ni PLATING 0.002MIN.
- NO BURR
CHAMFER 0.25 MAX x 45° IF EXIST.

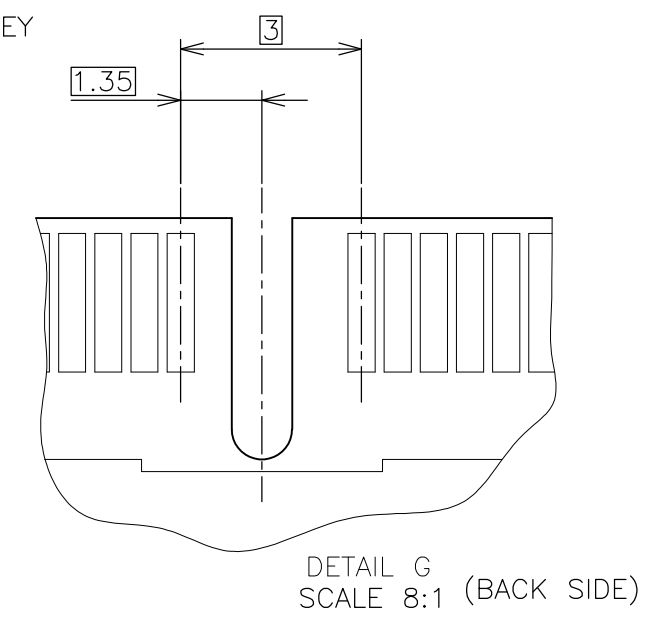
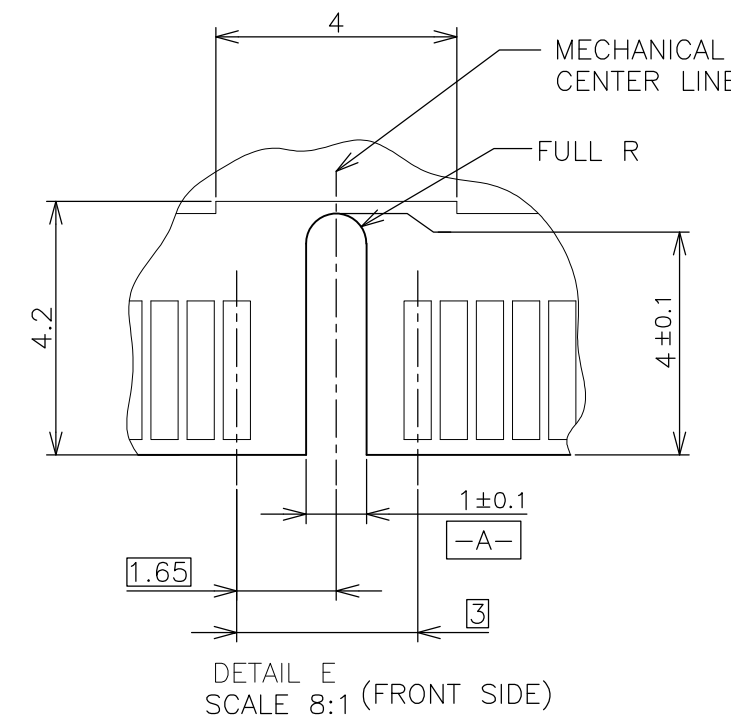
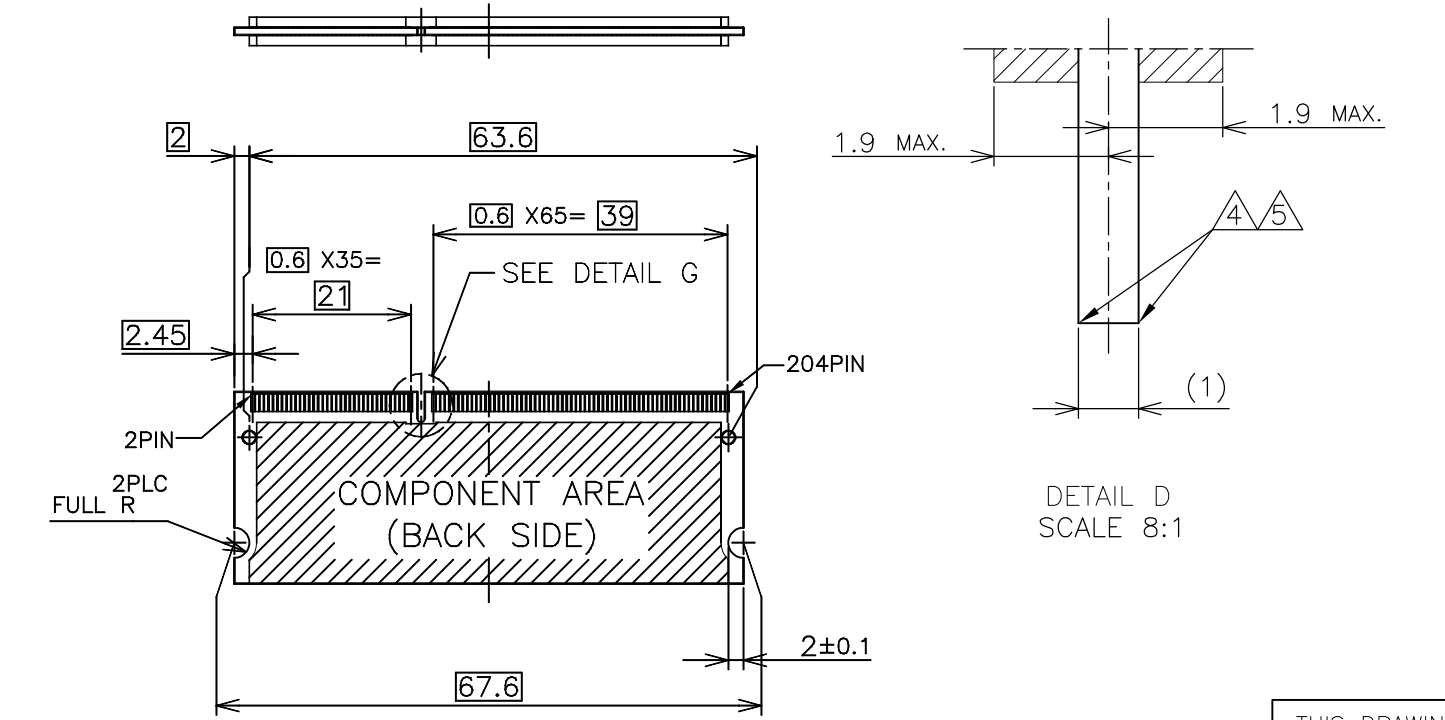

30	CA
31.75	BA
25.4	AA
H	SDRAM VARIATIONS

THIS DRAWING IS A CONTROLLED DOCUMENT.		DWN	TE Connectivity NAME DDR3 SODIMM SOCKET 0.6mm PITCH 204POS 5.2mm HEIGHT STANDARD TYPE				
DIMENSIONS: MM		CHK					
TOLERANCES UNLESS OTHERWISE SPECIFIED:		APVD					
0 PLC ± 1 PLC ± 2 PLC ± 3 PLC ± 4 PLC ± ANGLES ± MATERIAL FINISH ±		PRODUCT SPEC					
MATERIAL		APVD	APPLICATION SPEC	SIZE	CAGE CODE	DRAWING NO	RESTRICTED TO
		WEIGHT	CUSTOMER DRAWING	A3	00779	C-2013289	-
		SCALE	SHEET	REV			
		2:1	4 OF 6	C			

THIS DRAWING IS UNPUBLISHED.

RELEASED FOR PUBLICATION SEP, 2007.

© COPYRIGHT 2007 By -

ALL RIGHTS RESERVED.

LOC	DIST	REVISIONS					
		P	LTR	DESCRIPTION	DATE	DWN	APVD
J	/	-	-	SEE SHEET 1	-	-	-

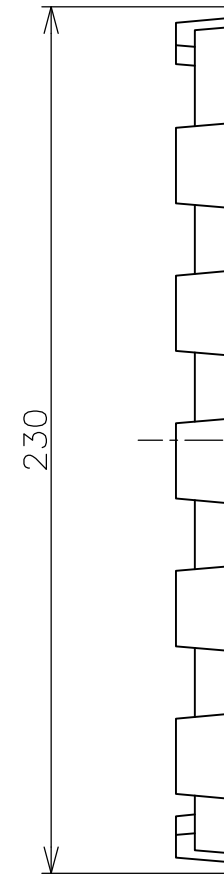
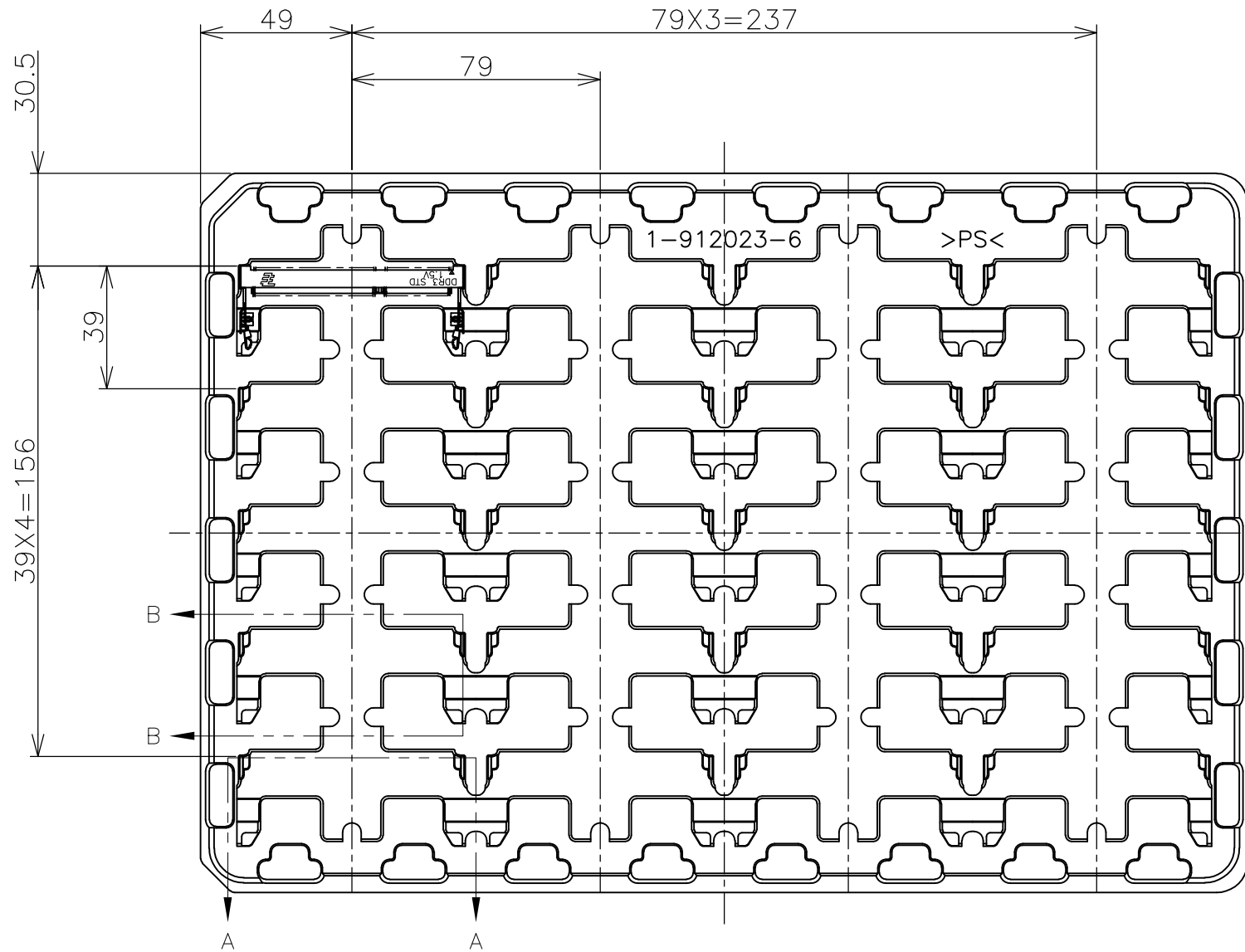

- (APPLIED TO SHEET 5)
 1. THE DIRECTION OF EACH CONNECTOR ON A TRAY IS REFERRED TO THIS DRAWING.
 2. GENERAL TOLERANCE: ±0.5, ±3°

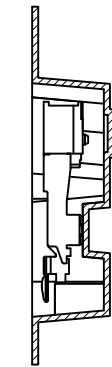

B-B SCALE 1:1

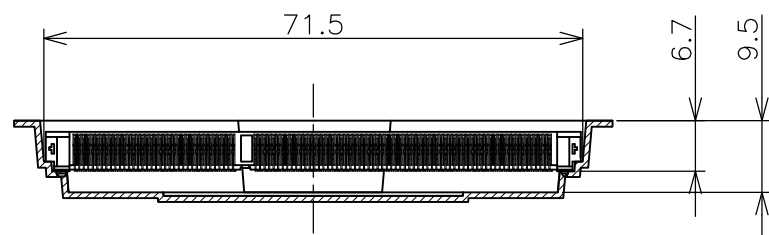
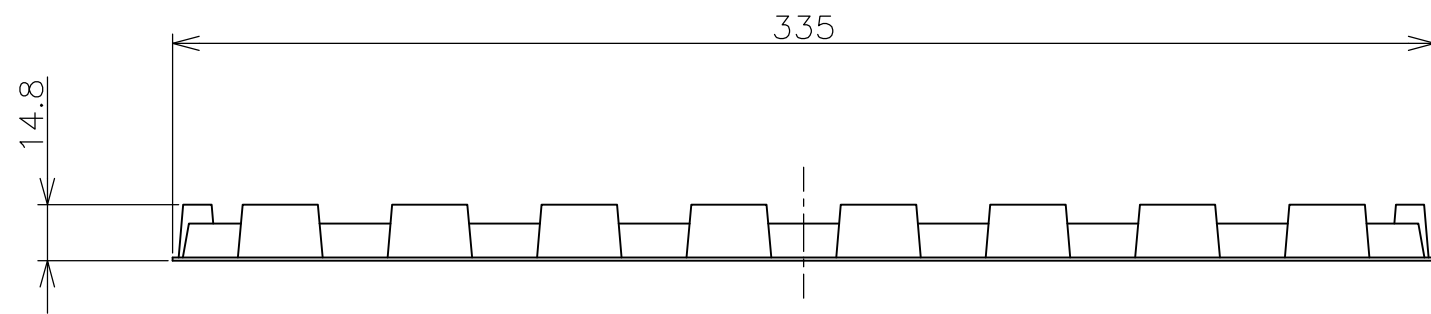

A-A SCALE 1:1 (180DEG. ROTATE)

240EA	20EA	*-2013289-*
QTY/BOX	QTY/TRAY	PART NO.

THIS DRAWING IS A CONTROLLED DOCUMENT.		DWN		TE Connectivity NAME DDR3 SODIMM SOCKET 0.6mm PITCH 204POS 5.2mm HEIGHT STANDARD TYPE	
DIMENSIONS: MM		CHK			
TOLERANCES UNLESS OTHERWISE SPECIFIED:		APVD			
0 PLC ± 0.5 1 PLC ± 0.5 2 PLC ± 0.5 3 PLC ± 0.5 4 PLC ± 0.5 ANGLES ± 3°		PRODUCT SPEC			
MATERIAL		FINISH		APPLICATION SPEC	
		WEIGHT		SIZE	RESTRICTED TO
		CUSTOMER DRAWING		A300779	C-2013289
		SCALE 1:2		SHEET 5 of 6	REV C

THIS DRAWING IS UNPUBLISHED. RELEASED FOR PUBLICATION SEP, 2007.
 © COPYRIGHT 2007 By - ALL RIGHTS RESERVED.

LOC		DIST		REVISIONS				
P	LTR	DESCRIPTION			DATE	DWN	APVD	
	-	SEE SHEET 1			-	-	-	

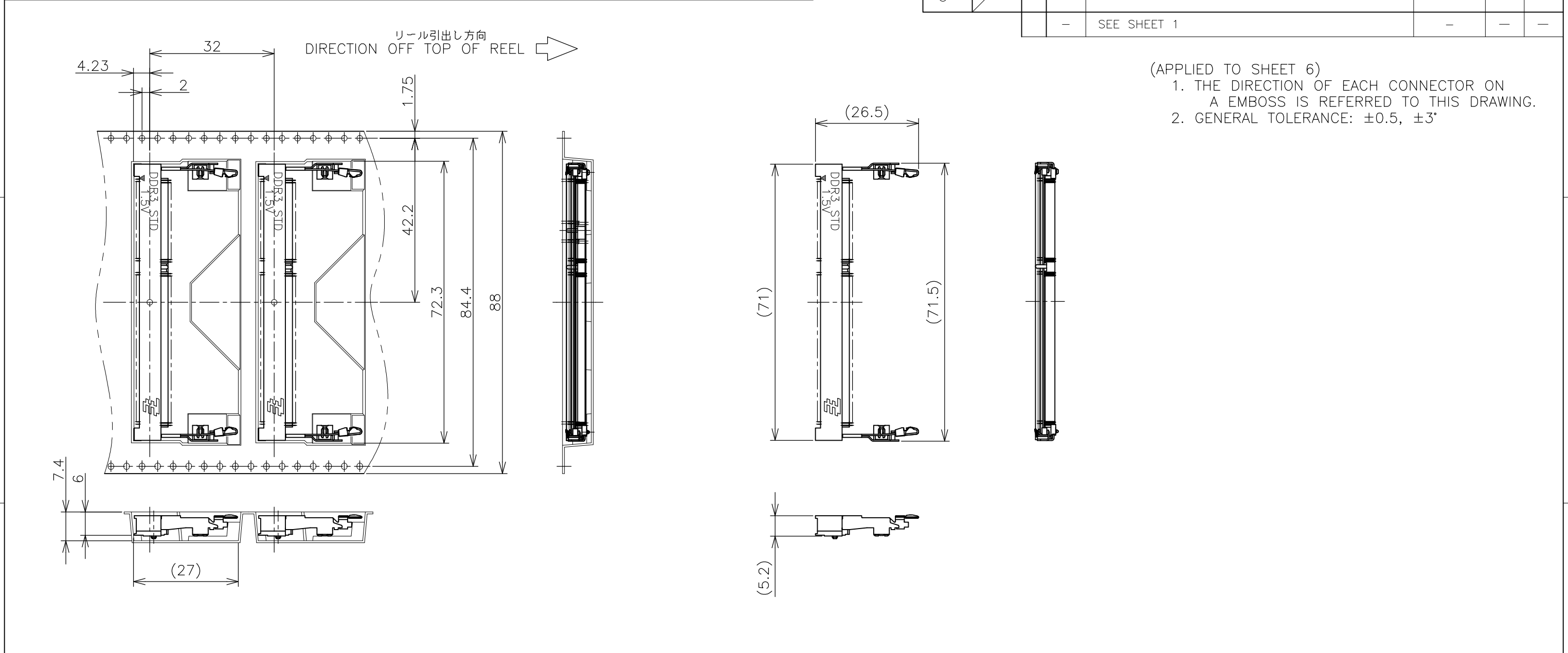

(APPLIED TO SHEET 6)
 1. THE DIRECTION OF EACH CONNECTOR ON A EMBOSS IS REFERRED TO THIS DRAWING.
 2. GENERAL TOLERANCE: ± 0.5 , $\pm 3^\circ$

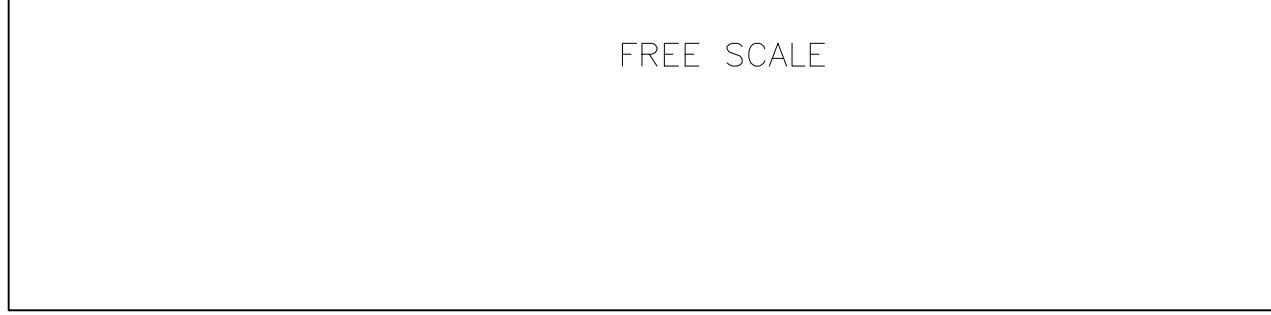
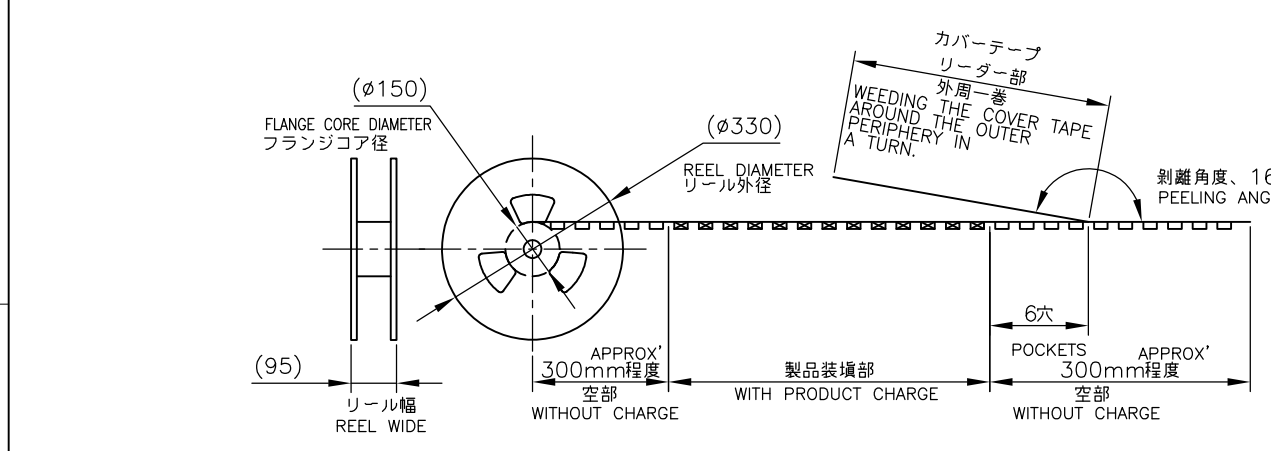

THIS DRAWING IS A CONTROLLED DOCUMENT.

DIMENSIONS: MM	TOLERANCES UNLESS OTHERWISE SPECIFIED:
	0 PLC ± 0.5
	1 PLC ± 0.5
	2 PLC ± 0.5
	3 PLC ± 0.5
	4 PLC ± 0.5
	ANGLES $\pm 3^\circ$
MATERIAL	FINISH

DWN	200EA			*-2013289-*		
CHK	QTY/REEL			PART NO.		
APVD	STE TE Connectivity					
PRODUCT SPEC	NAME DDR3 SODIMM SOCKET 0.6mm PITCH 204POS 5.2mm HEIGHT STANDARD TYPE					
APPLICATION SPEC	SIZE	CAGE CODE	DRAWING NO	RESTRICTED TO		
WEIGHT	A3	00779	C-2013289	-		
CUSTOMER DRAWING			SCALE	SHEET	REV	
			1:2	6 OF 6	C	

X-ON Electronics

Largest Supplier of Electrical and Electronic Components

Click to view similar products for [DIMM Connectors](#) category:

Click to view products by [TE Connectivity](#) manufacturer:

Other Similar products are found below :

[1-1932649-2](#) [1-1761024-0](#) [2309411-5](#) [10116658-252ASLF](#) [5390471-1](#) [2309413-3](#) [78507-0061](#) [KIT-SODIMM-1X16GB/01](#) [10129206-0010013LF](#) [10086891-052TSLF](#) [10079192-11102LF](#) [10116658-152FSLF](#) [10129206-0011113LF](#) [1-2308107-0](#) [2013310-1](#) [2013289-1](#) [390111-1](#) [390112-1](#) [2309413-1](#) [2309407-1](#) [2309414-1](#) [10081530-12208LF](#) [151080-0001](#) [78726-1004](#) [10005639-11107LF](#) [10005639-11109LF](#) [10005639-12207LF](#) [10023061-10207LF](#) [10033853-252FSLF](#) [10033853-052ASLF](#) [10033853-052FSLF](#) [10033853-152FSLF](#) [10033854-052FSLF](#) [10034542-10002LF](#) [10037402-12207LF](#) [10081530-11107LF](#) [10081530-12207LF](#) [10081530-12218LF](#) [10081530-12228LF](#) [10124632-0030001LF](#) [10124806-01006LF](#) [10145226-0241N13LF](#) [59354-052FSLF](#) [59355-052FSLF](#) [DDR4288S0211TF](#) [DDR4288S0511H](#) [DDR4288S0511TF](#) [DDR4288V0123TF](#) [DDR4288V0213TF](#) [DDR502112001K](#)