

THIS DRAWING IS UNPUBLISHED. RELEASED FOR PUBLICATION SEP ,2007.
 © COPYRIGHT 2007 By - ALL RIGHTS RESERVED.

LOC	DIST	REVISIONS			
P	LTR	DESCRIPTION	DATE	DWN	APVD
	C	REVISED PER ECR-12-004002	01MAR2012	W.W	C.W

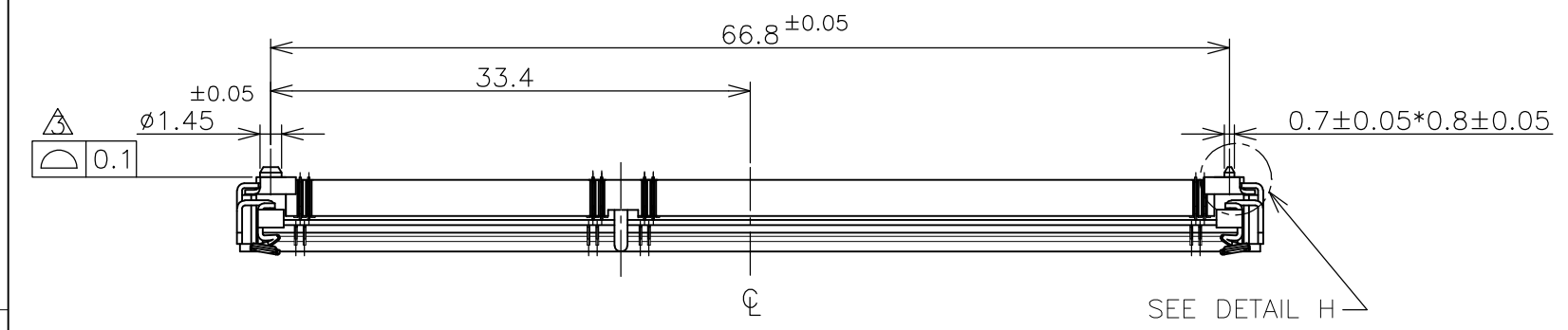

HOW TO MATE AND UNMATE

- MATE: ① → ④
 UNMATE: ⑤ → ⑦

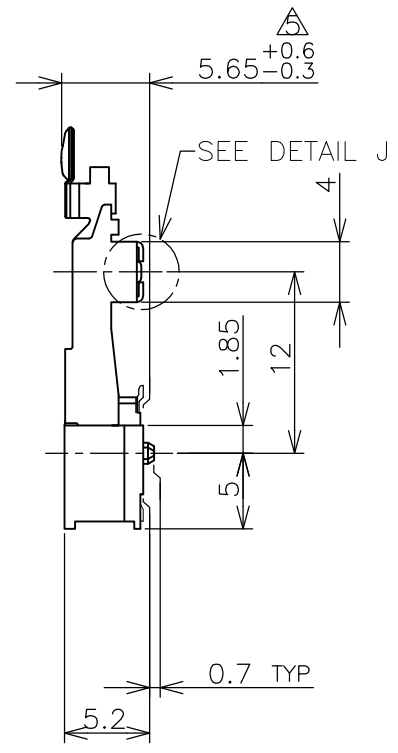
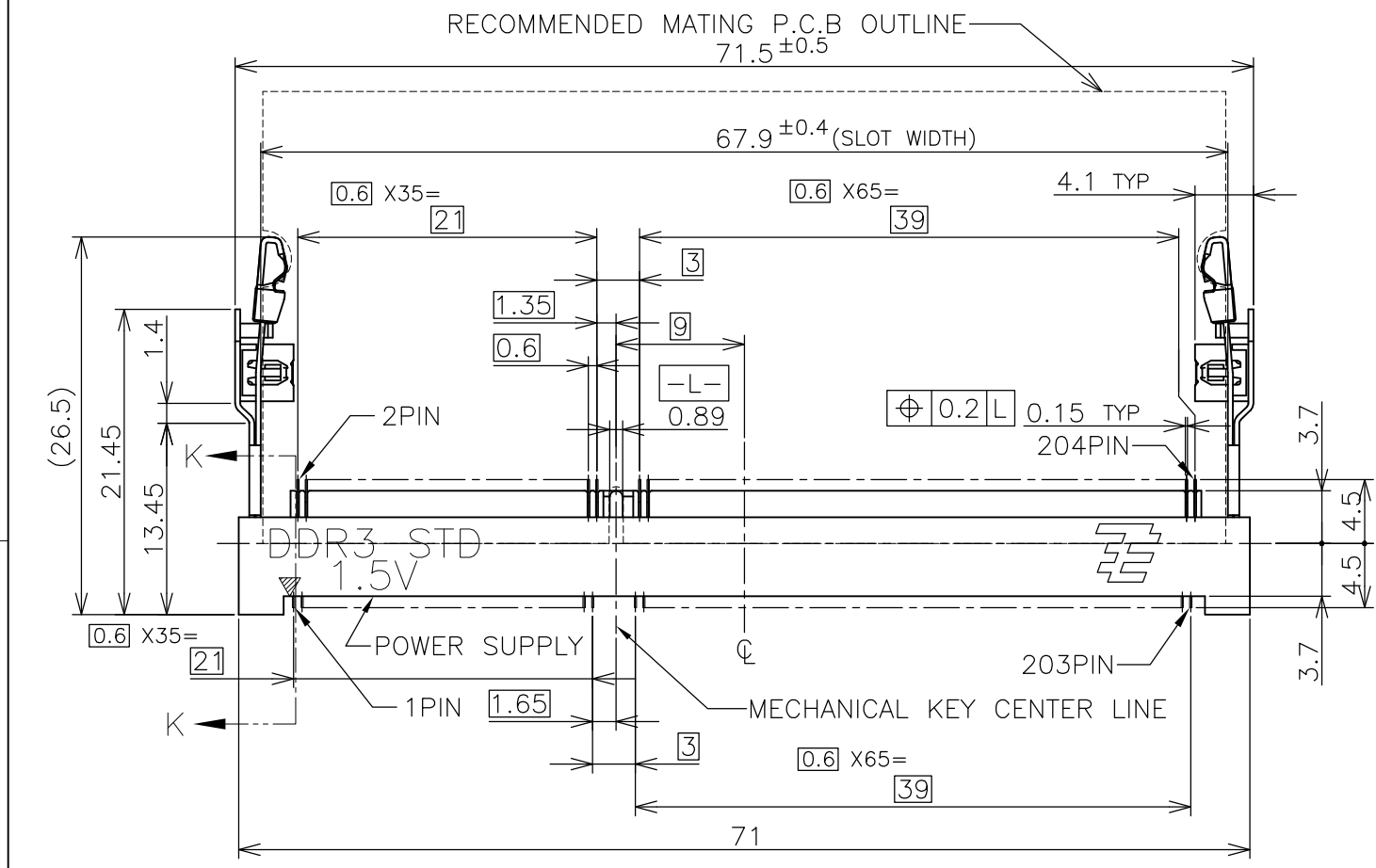
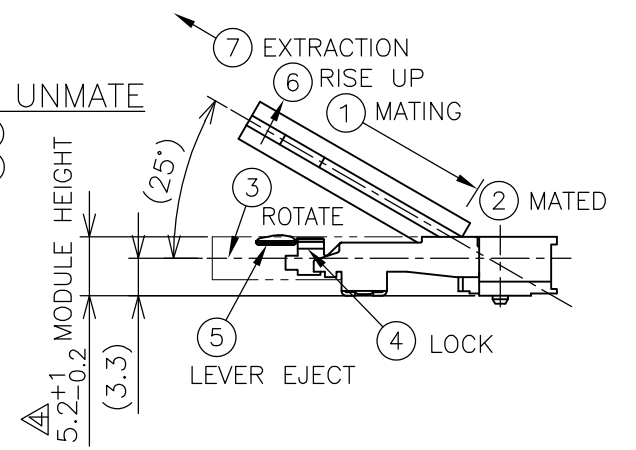

(APPLIED TO SHEET 1-3)

- MATERIAL ; HOUSING: HIGH TEMPERATURE THERMO PLASTIC UL94V-0
 COLOR: BLACK
 CONTACT: COPPER ARROY
 LOCK LEVER: STAINLESS STEEL
 PEG: COPPER ARROY
 - 2-1. FINISH ; CONTACT AREA: GOLD FLASH ALL OVER NICKEL.
 SOLDERING AREA: GOLD FLASH PLATING
 PEG: TIN PLATING
 - 2-2. FINISH ; CONTACT AREA: 0.000254MIN GOLD ALL OVER NICKEL.
 SOLDERING AREA: GOLD FLASH PLATING
 PEG: TIN PLATING
 - 2-3. FINISH ; CONTACT AREA: 0.00076MIN GOLD ALL OVER NICKEL.
 SOLDERING AREA: GOLD FLASH PLATING
 PEG: TIN PLATING
- △ COPLANARITY: 0.1 MAX. (BEFORE SOLDERING)
 △ THE FLOATING VALUE BY SOLDERING IS NOT INCLUDED.
 △ NOT MATING CONDITION.
6. IF THE MODULE DOESN'T INSERT AND LOCK IN THE LATCH SMOOTHLY, OPEN WIDE BOTH LATCHES BY MANUAL. AND THE MODULE MUST BE INSERTED AND LOCKED IN THE LATCH.

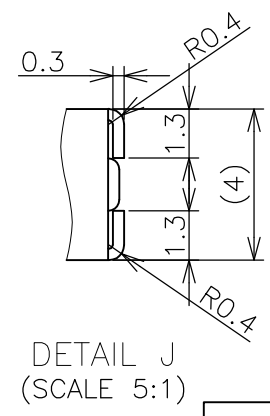
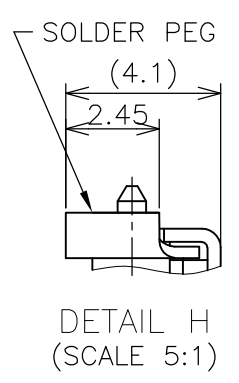
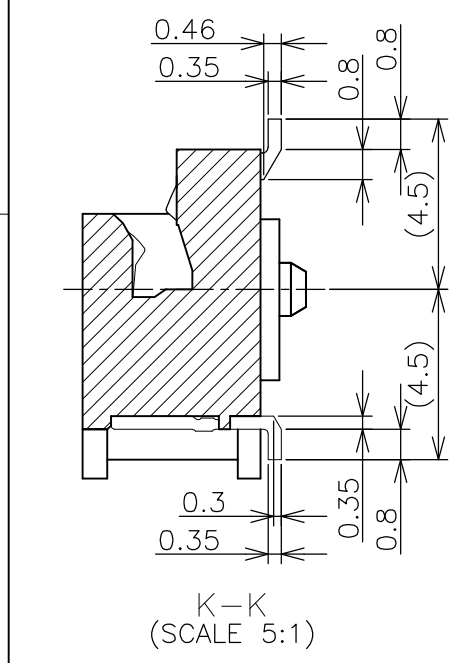

GENERAL TOLERANCE
 10 ≥ : ±0.2
 30 ≥ > 10 : ±0.25
 100 ≥ > 30 : ±0.3
 ANGLES : ±3°

THIS DRAWING IS A CONTROLLED DOCUMENT.		DWN T.FUMIKURA 18SEP2007	TE Connectivity		
DIMENSIONS: MM		CHK K.IKEGAMI 18SEP2007			
TOLERANCES UNLESS OTHERWISE SPECIFIED:		APVD K.IKEGAMI 18SEP2007	NAME		
0 PLC ±		108-78493			
1 PLC ±		APPLICATION SPEC			
2 PLC ±		SIZE CAGE CODE DRAWING NO RESTRICTED TO			
3 PLC ±		A3 00779 C-2013289			
4 PLC ±		WEIGHT 4.4g			
ANGLES ±		CUSTOMER DRAWING SCALE 2:1 SHEET 1 OF 6 REV C			
FINISH ±					

THIS DRAWING IS UNPUBLISHED. RELEASED FOR PUBLICATION SEP ,2007.
 © COPYRIGHT 2007 By - ALL RIGHTS RESERVED.

LOC		DIST		REVISIONS				
P	LTR	DESCRIPTION			DATE	DWN	APVD	
	-	SEE SHEET 1			-	-	-	

TOOLING STATUS	PACKAGING TYPE	BOSS TYPE	HOUSING COLOR	FINISH	POWER SUPPLY	POS	PART NO.
AVAILABLE	ENBOSS (SEE SHEET 6)	WITH BOSS	BLACK	NOTE 2-3	1.5V	204	2-2013289-3
AVAILABLE	ENBOSS (SEE SHEET 6)	WITH BOSS	BLACK	NOTE 2-2	1.5V	204	2-2013289-2
AVAILABLE	ENBOSS (SEE SHEET 6)	WITH BOSS	BLACK	NOTE 2-1	1.5V	204	2-2013289-1
AVAILABLE	SEMI-HARD TRAY (SEE SHEET 5)	WITH BOSS	BLACK	NOTE 2-3	1.5V	204	2013289-3
AVAILABLE	SEMI-HARD TRAY (SEE SHEET 5)	WITH BOSS	BLACK	NOTE 2-2	1.5V	204	2013289-2
AVAILABLE	SEMI-HARD TRAY (SEE SHEET 5)	WITH BOSS	BLACK	NOTE 2-1	1.5V	204	2013289-1

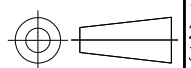
THIS DRAWING IS A CONTROLLED DOCUMENT.		DWN		 TE Connectivity			
DIMENSIONS: MM		CHK					
		TOLERANCES UNLESS OTHERWISE SPECIFIED: 0 PLC ± 1 PLC ± 2 PLC ± 3 PLC ± 4 PLC ± ANGLES ±		NAME DDR3 SODIMM SOCKET 0.6mm PITCH 204POS 5.2mm HEIGHT STANDARD TYPE			
MATERIAL		FINISH		PRODUCT SPEC		RESTRICTED TO	
				APPLICATION SPEC		SIZE CAGE CODE DRAWING NO	
				WEIGHT		A3 00779 C-2013289	
CUSTOMER DRAWING				SCALE 2:1		SHEET 2 OF 6 REV C	

THIS DRAWING IS UNPUBLISHED. RELEASED FOR PUBLICATION SEP. 2007.
 © COPYRIGHT 2007 By - ALL RIGHTS RESERVED.

LOC	DIST	REVISIONS			
P	LTR	DESCRIPTION	DATE	DWN	APVD
J		SEE SHEET 1	-	-	-

REFERENCE P.C.BOARD PATTERN LAYOUT
 (CONNECTOR MOUNTING SIDE)

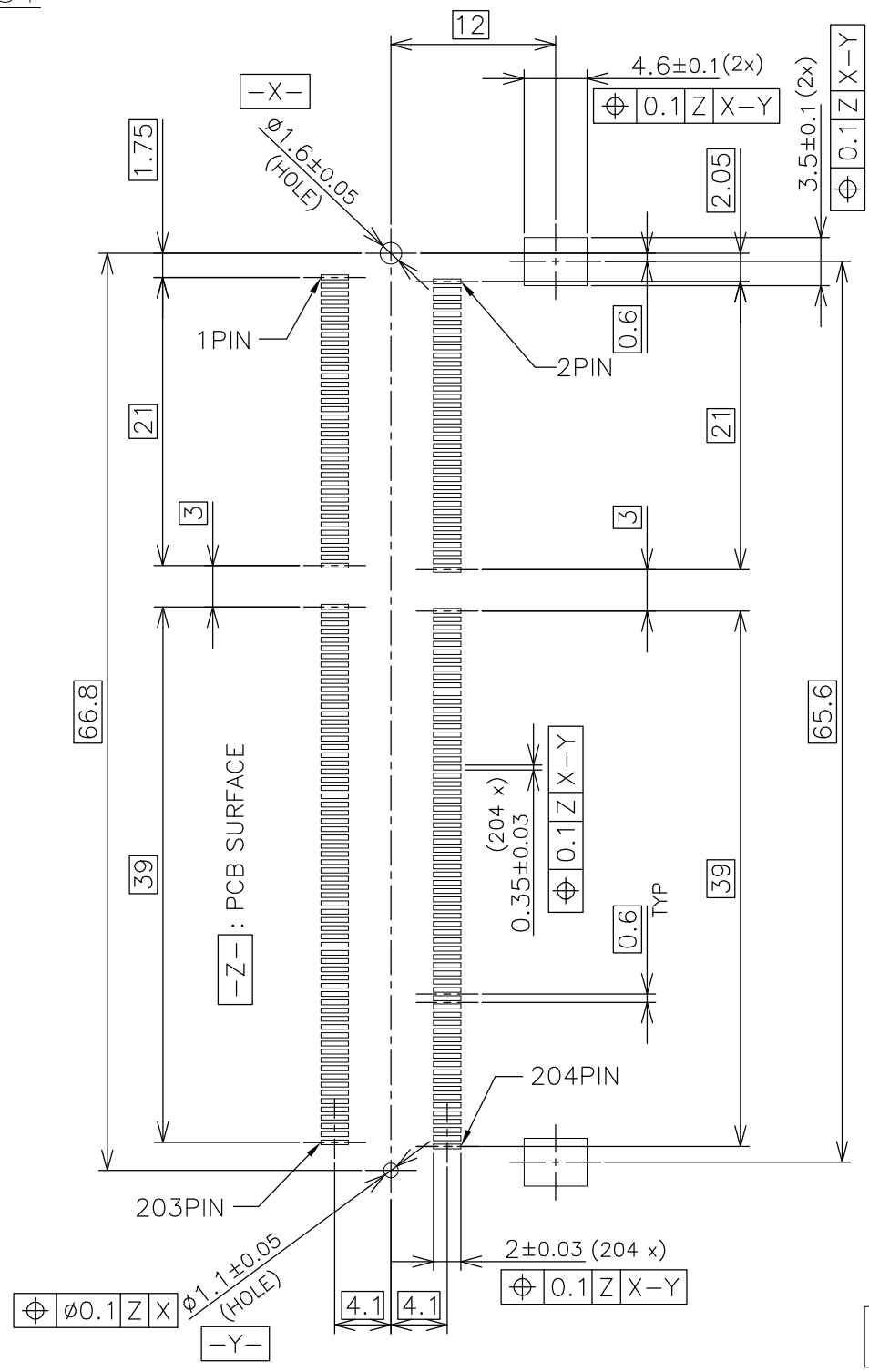

STD TYPE

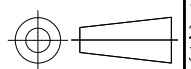
THIS DRAWING IS A CONTROLLED DOCUMENT.		DWN		 TE Connectivity	
DIMENSIONS: MM		CHK			
		APVD		NAME	
		PRODUCT SPEC		DDR3 SODIMM SOCKET 0.6mm PITCH 204POS 5.2mm HEIGHT STANDARD TYPE	
MATERIAL		FINISH		SIZE	RESTRICTED TO
				A3	
				CAGE CODE	
				DRAWING NO	
				C-2013289	
				WEIGHT	
				CUSTOMER DRAWING	
				SCALE	
				2:1	
				SHEET	
				3 of 6	
				REV	
				C	

LOC	DIST	REVISIONS					
		P	LTR	DESCRIPTION	DATE	DWN	APVD
J	/	-	-	SEE SHEET 1	-	-	-

REFERENCE MATING P.C.B CONFIGURATION

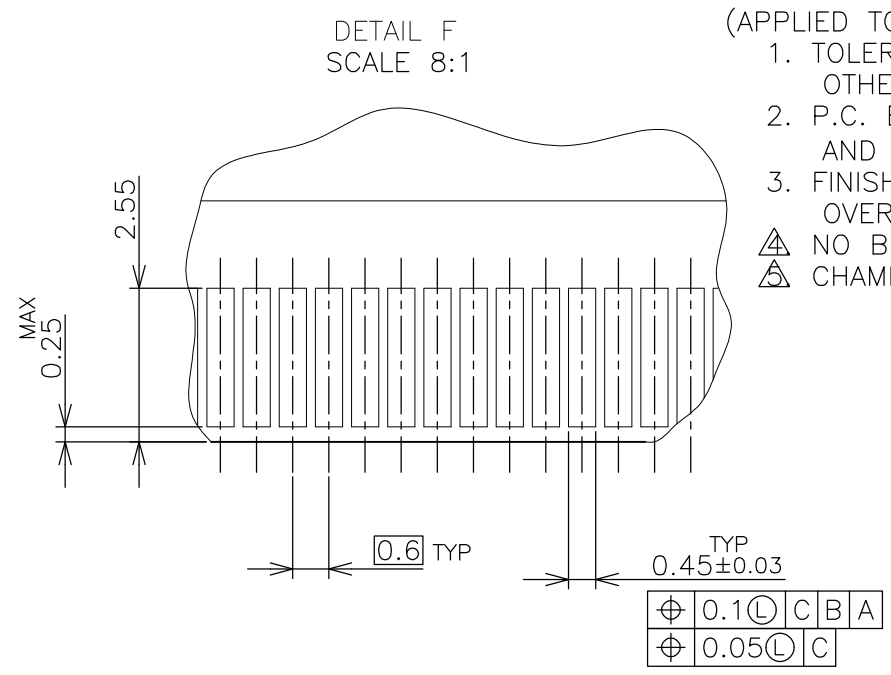
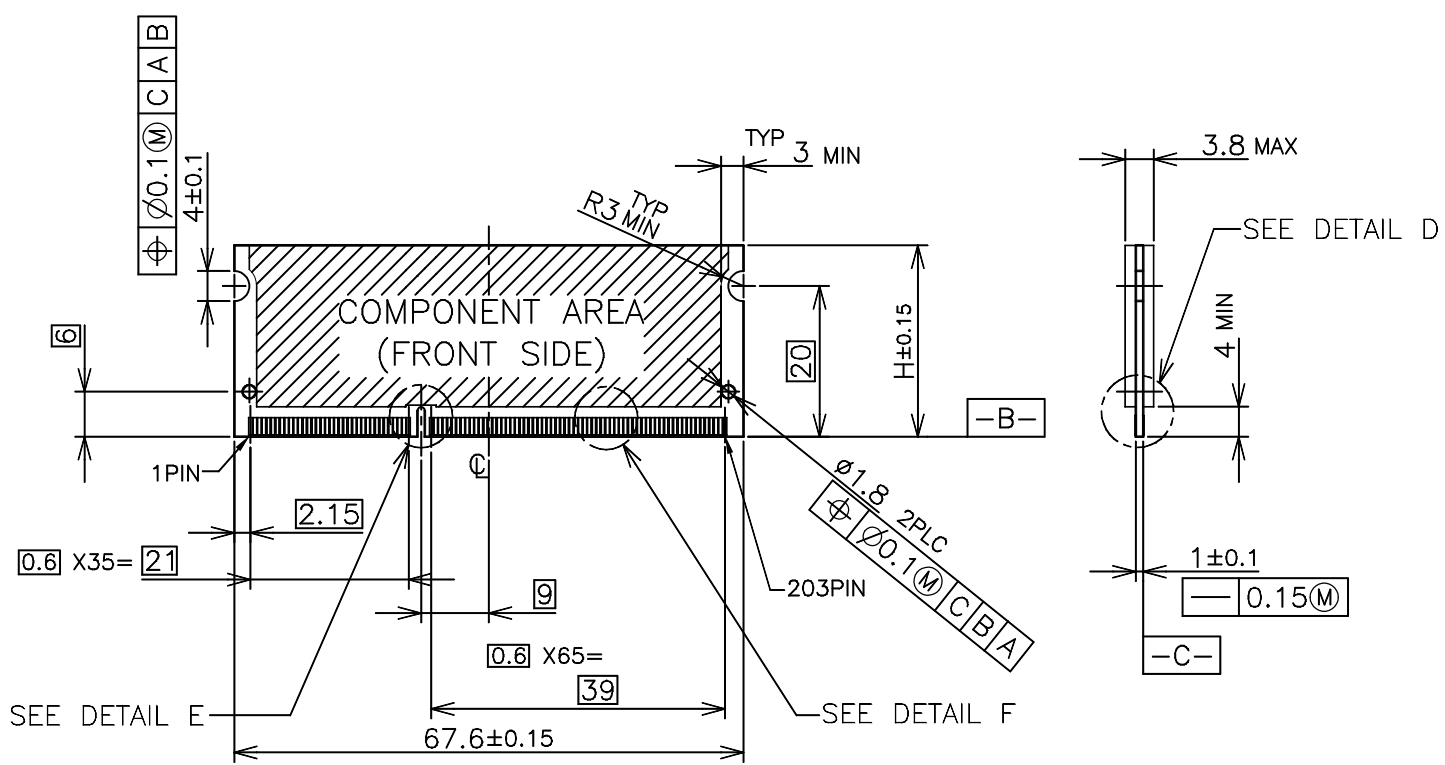

- (APPLIED TO SHEET 4)
1. TOLERANCES ON ALL DIMENSIONS ±0.15 UNLESS OTHERWISE SPECIFIED.
 2. P.C. BOARD THICKNESS APPLIES ACROSS TABS AND INCLUDES PLATING AND/OR METALIZATION.
 3. FINISH OF PAD : GOLD PLATING 0.00076 MIN. OVER Ni PLATING 0.002MIN.
- NO BURR
CHAMFER 0.25 MAX x 45° IF EXIST.

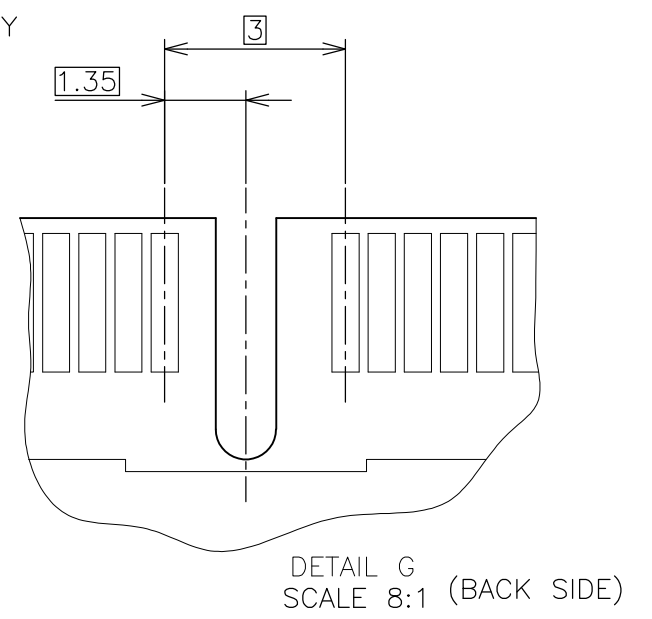
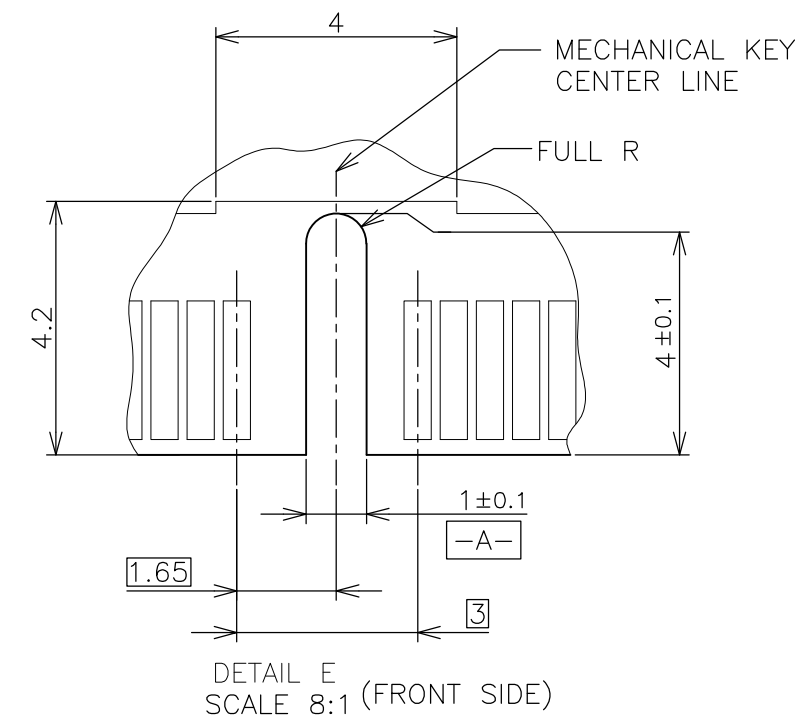
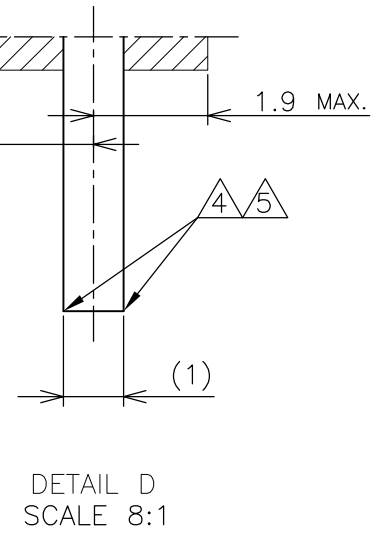
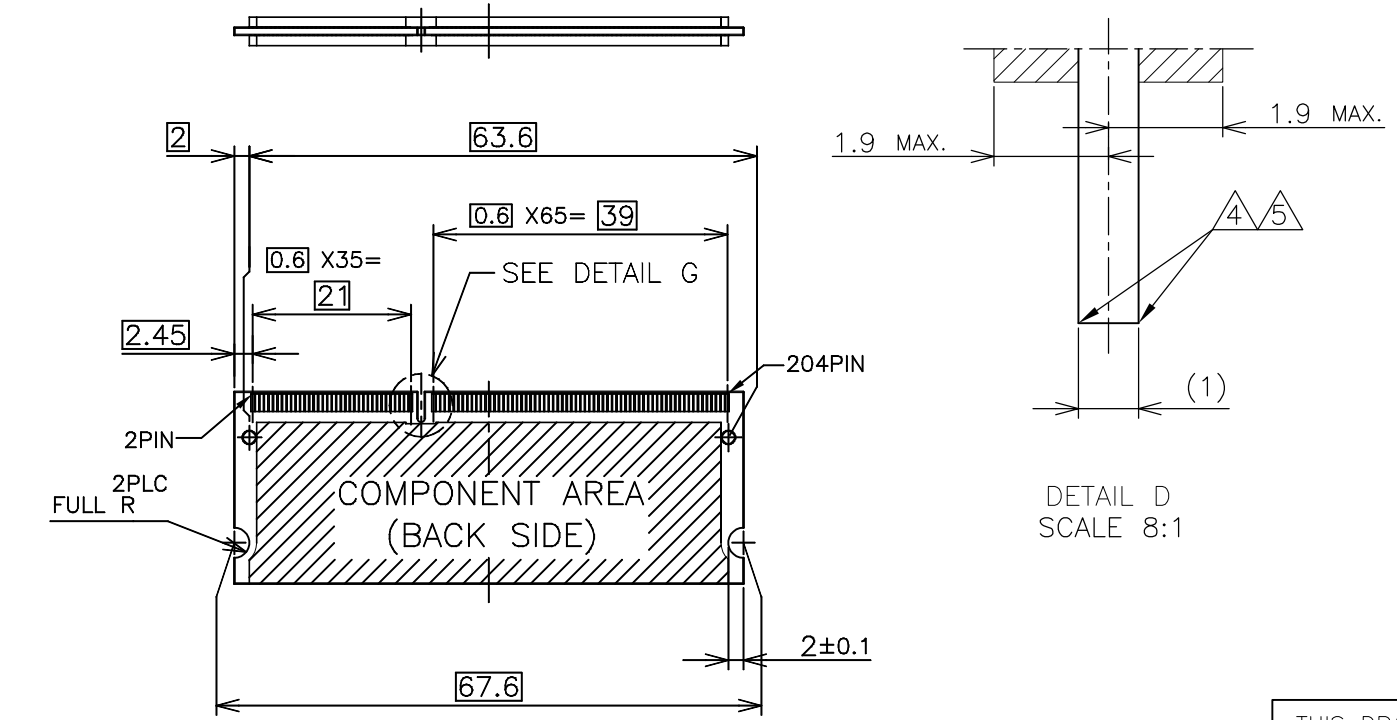

30	CA
31.75	BA
25.4	AA
H	SDRAM VARIATIONS

THIS DRAWING IS A CONTROLLED DOCUMENT.		DWN	TE Connectivity NAME DDR3 SODIMM SOCKET 0.6mm PITCH 204POS 5.2mm HEIGHT STANDARD TYPE		
DIMENSIONS: MM		CHK			
TOLERANCES UNLESS OTHERWISE SPECIFIED:		APVD			
0 PLC ± 1 PLC ± 2 PLC ± 3 PLC ± 4 PLC ± ANGLES ± MATERIAL FINISH ±		PRODUCT SPEC			
MATERIAL		APVD	APPLICATION SPEC	SIZE	RESTRICTED TO
		WEIGHT	SIZE	CAGE CODE	DRAWING NO
		CUSTOMER DRAWING	A3	00779	C-2013289
		SCALE	2:1	SHEET	4 OF 6
		REV	C		

THIS DRAWING IS UNPUBLISHED.

RELEASED FOR PUBLICATION SEP ,2007.

© COPYRIGHT 2007 By -

ALL RIGHTS RESERVED.

LOC	DIST	REVISIONS					
		P	LTR	DESCRIPTION	DATE	DWN	APVD
J	/	-	-	SEE SHEET 1	-	-	-

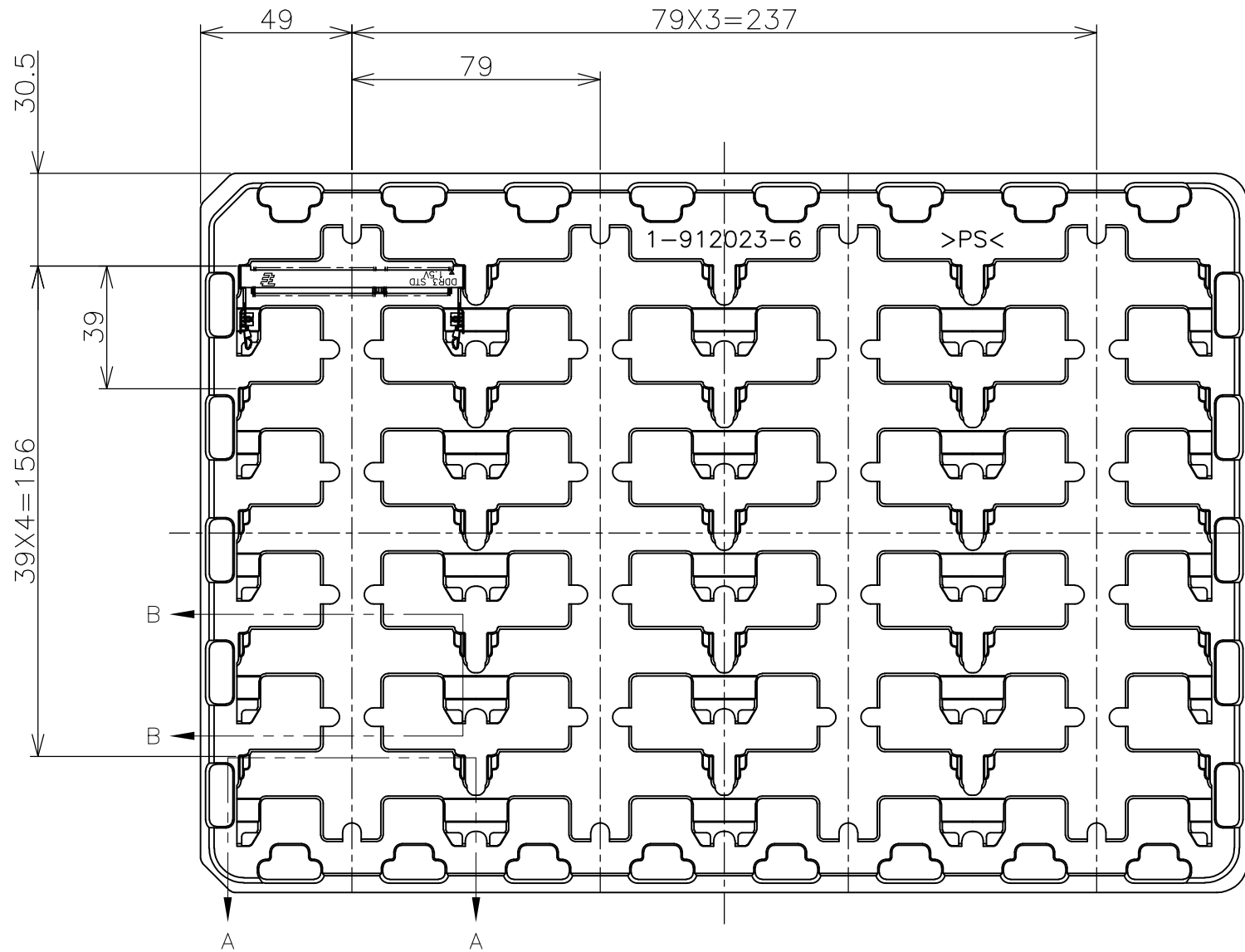

- (APPLIED TO SHEET 5)
1. THE DIRECTION OF EACH CONNECTOR ON A TRAY IS REFERRED TO THIS DRAWING.
 2. GENERAL TOLERANCE: ± 0.5 , $\pm 3^\circ$

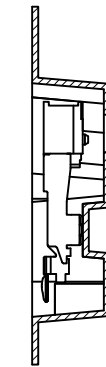
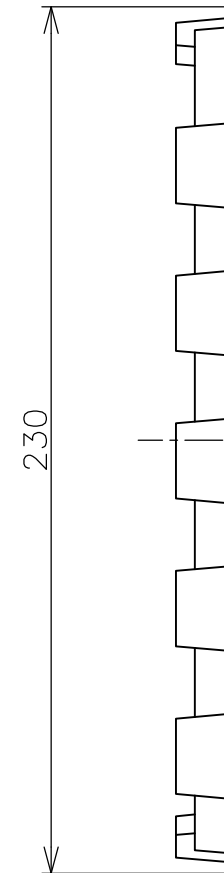

B-B SCALE 1:1

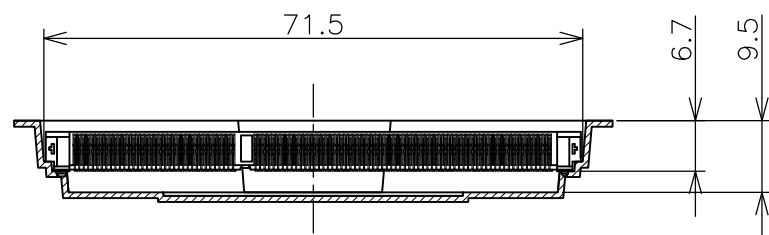
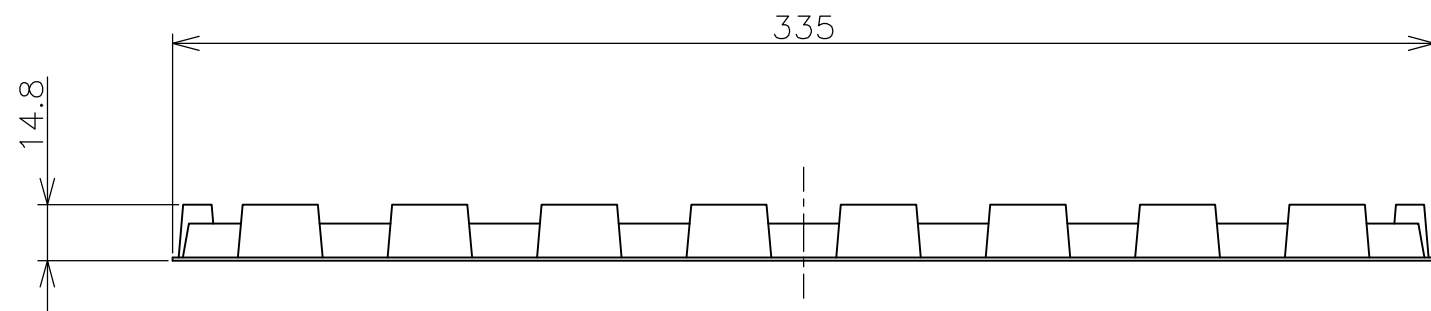

A-A SCALE 1:1 (180DEG. ROTATE)

240EA	20EA	*-2013289-*
QTY/BOX	QTY/TRAY	PART NO.

THIS DRAWING IS A CONTROLLED DOCUMENT.		DWN	STE TE Connectivity		
DIMENSIONS: MM		CHK			
TOLERANCES UNLESS OTHERWISE SPECIFIED:		APVD	NAME		
0 PLC ± 0.5		PRODUCT SPEC	DDR3 SODIMM SOCKET		
1 PLC ± 0.5		APPLICATION SPEC	0.6mm PITCH 204POS		
2 PLC ± 0.5		WEIGHT	SIZE	CAGE CODE	DRAWING NO
3 PLC ± 0.5		CUSTOMER DRAWING	A3	00779	C-2013289
4 PLC ± 0.5			SCALE	SHEET	REV
ANGLES $\pm 3^\circ$			1:2	5 of 6	C
MATERIAL		FINISH	RESTRICTED TO		

THIS DRAWING IS UNPUBLISHED. RELEASED FOR PUBLICATION SEP ,2007.
 © COPYRIGHT 2007 By - ALL RIGHTS RESERVED.

LOC		DIST		REVISIONS				
P	LTR	DESCRIPTION			DATE	DWN	APVD	
	-	SEE SHEET 1			-	-	-	

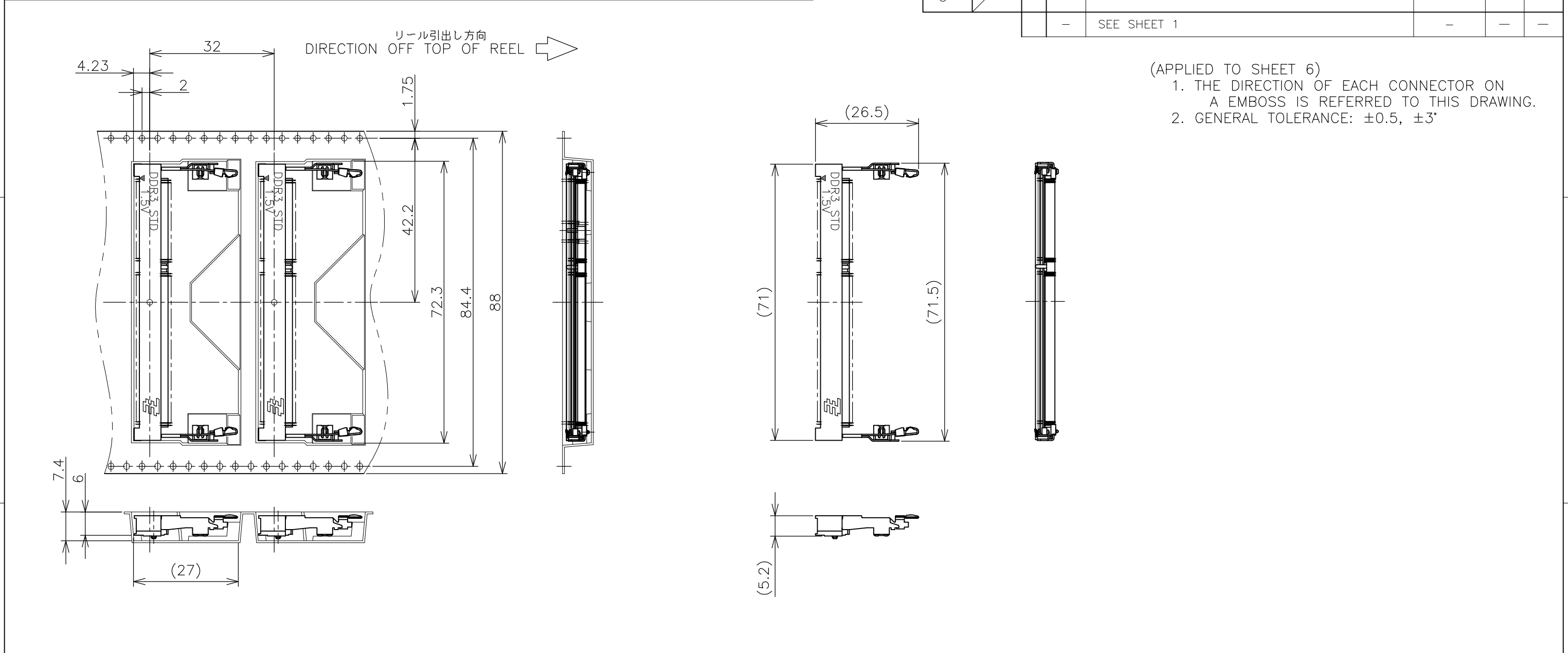

(APPLIED TO SHEET 6)
 1. THE DIRECTION OF EACH CONNECTOR ON A EMBOSS IS REFERRED TO THIS DRAWING.
 2. GENERAL TOLERANCE: ±0.5, ±3°

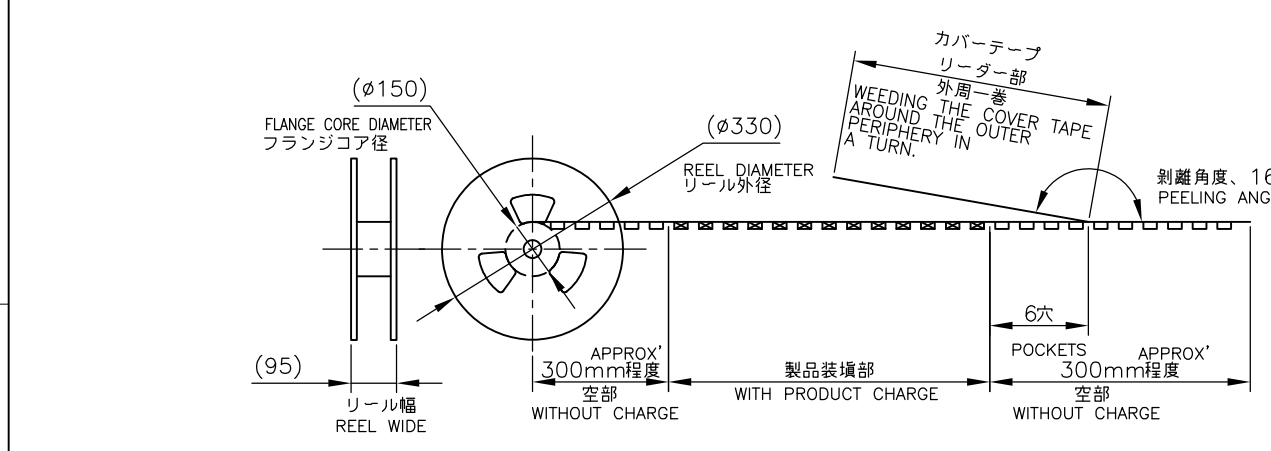

FREE SCALE

THIS DRAWING IS A CONTROLLED DOCUMENT.		DWN		TE Connectivity NAME DDR3 SODIMM SOCKET 0.6mm PITCH 204POS 5.2mm HEIGHT STANDARD TYPE	
DIMENSIONS: MM		CHK			
TOLERANCES UNLESS OTHERWISE SPECIFIED:		APVD			
MATERIAL		PRODUCT SPEC			
FINISH		APPLICATION SPEC		SIZE	
		WEIGHT		CAGE CODE	
		CUSTOMER DRAWING		DRAWING NO	
				RESTRICTED TO	
				A3 00779 C-2013289	
				SCALE 1:2	
				SHEET 6 OF 6	
				REV C	

X-ON Electronics

Largest Supplier of Electrical and Electronic Components

Click to view similar products for [DIMM Connectors](#) category:

Click to view products by [TE Connectivity](#) manufacturer:

Other Similar products are found below :

[1-1932649-2](#) [1-1761024-0](#) [2309411-5](#) [10116658-252ASLF](#) [5390471-1](#) [2309413-3](#) [78507-0061](#) [KIT-SODIMM-1X16GB/01](#) [10129206-0010013LF](#) [10086891-052TSLF](#) [10079192-11102LF](#) [10116658-152FSLF](#) [10129206-0011113LF](#) [1-2308107-0](#) [2013310-1](#) [2013289-1](#) [390111-1](#) [390112-1](#) [2309413-1](#) [2309407-1](#) [2309414-1](#) [10081530-12208LF](#) [151080-0001](#) [78726-1004](#) [10005639-11107LF](#) [10005639-11109LF](#) [10005639-12207LF](#) [10023061-10207LF](#) [10033853-252FSLF](#) [10033853-052ASLF](#) [10033853-052FSLF](#) [10033853-152FSLF](#) [10033854-052FSLF](#) [10034542-10002LF](#) [10037402-12207LF](#) [10081530-11107LF](#) [10081530-12207LF](#) [10081530-12218LF](#) [10081530-12228LF](#) [10124632-0030001LF](#) [10124806-01006LF](#) [10145226-0241N13LF](#) [59354-052FSLF](#) [59355-052FSLF](#) [DDR4288S0211TF](#) [DDR4288S0511H](#) [DDR4288S0511TF](#) [DDR4288V0123TF](#) [DDR4288V0213TF](#) [DDR502112001K](#)