

REVISIONS				
P.	LTN.	DESCRIPTION	DATE	APPROV.
A		RELEASED PER ECO-15-012149	21AUG2015	DLD MDB
B		REVISED PER ECO-16-010785	10NOV2016	DLD JLT
C		REVISED PER ECO-17-003504	14MAR2017	DLD JLT

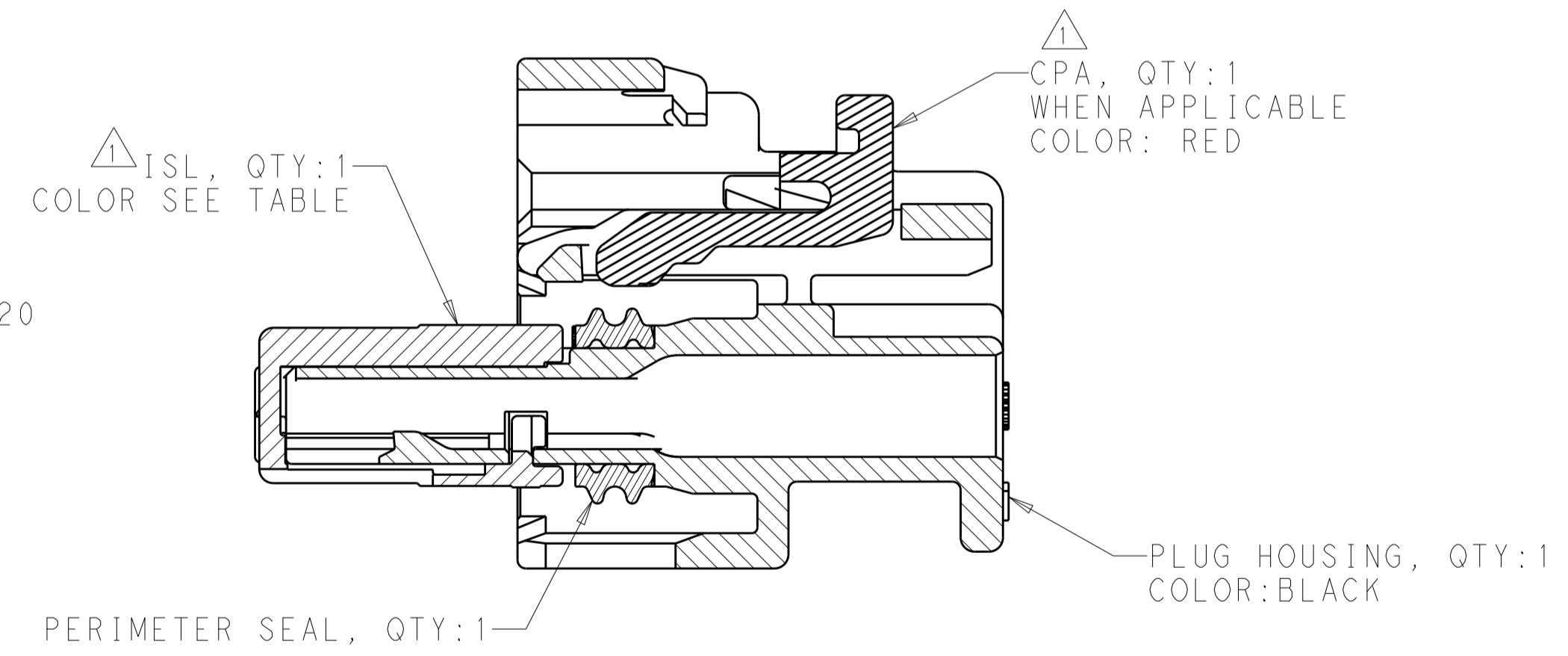
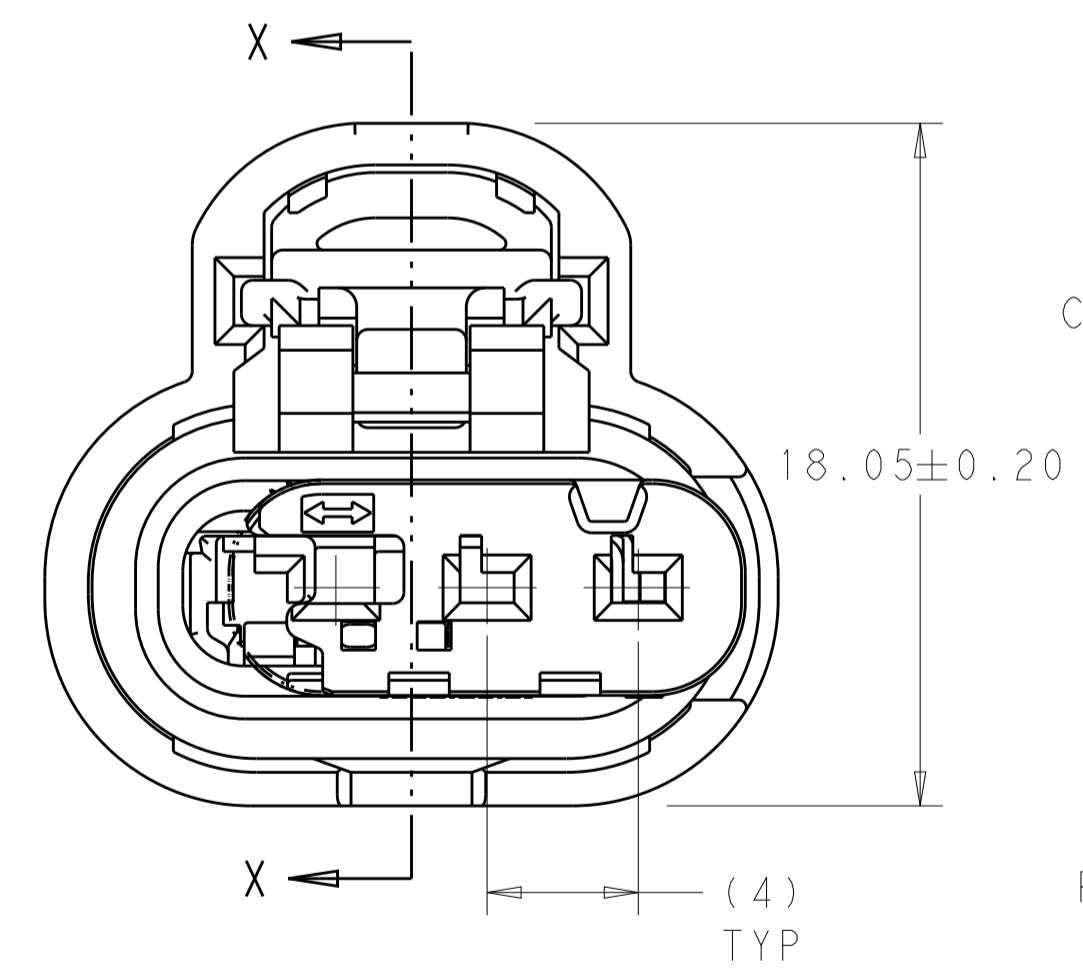
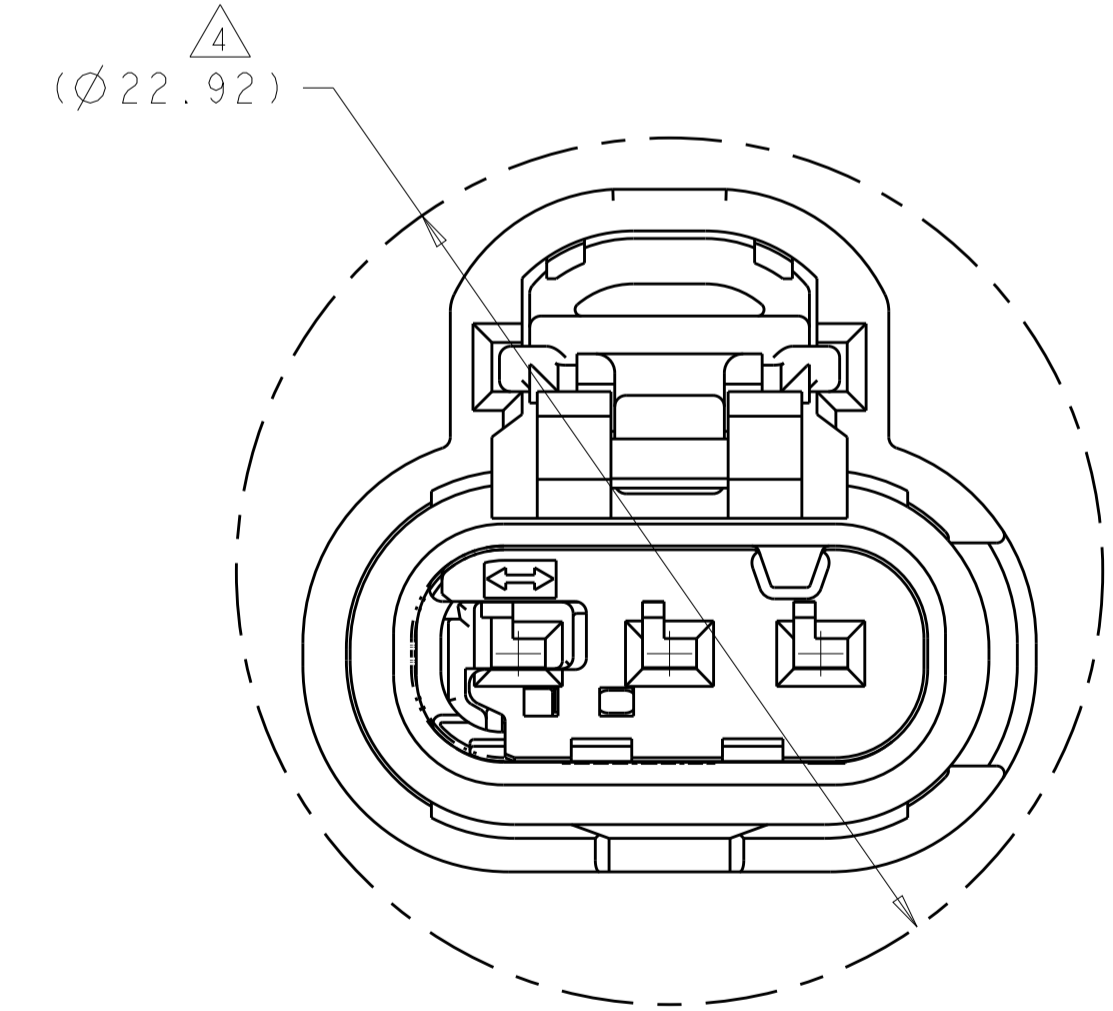
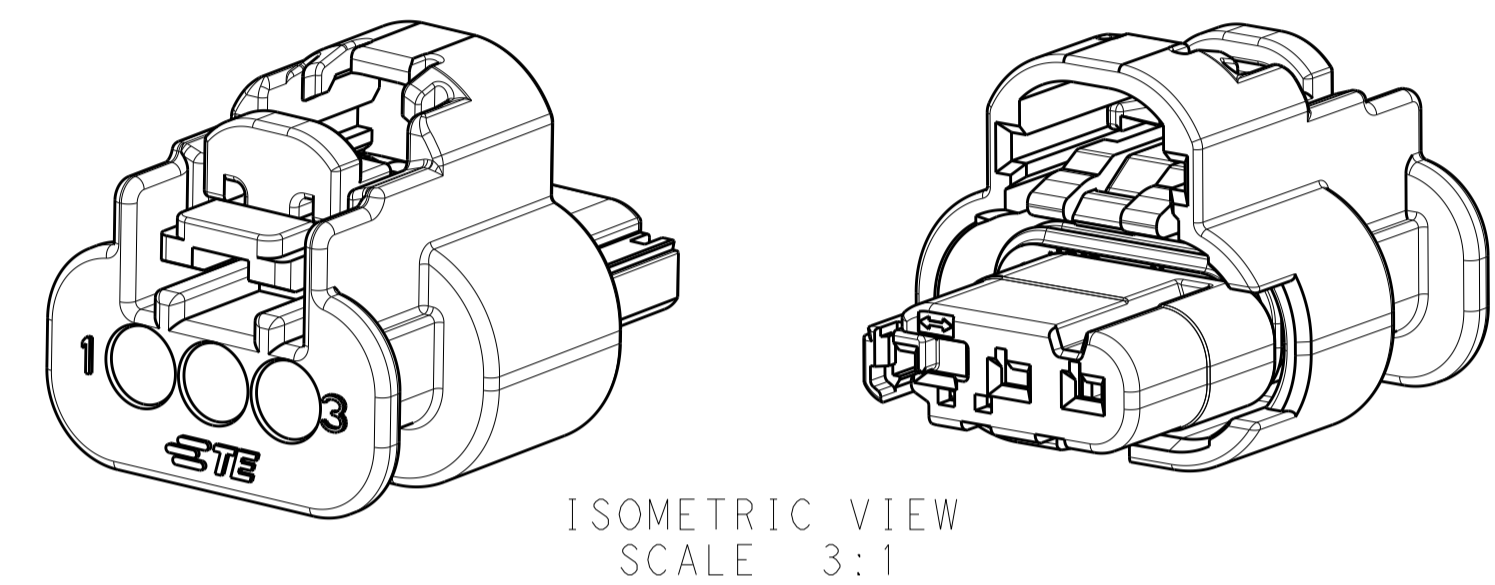
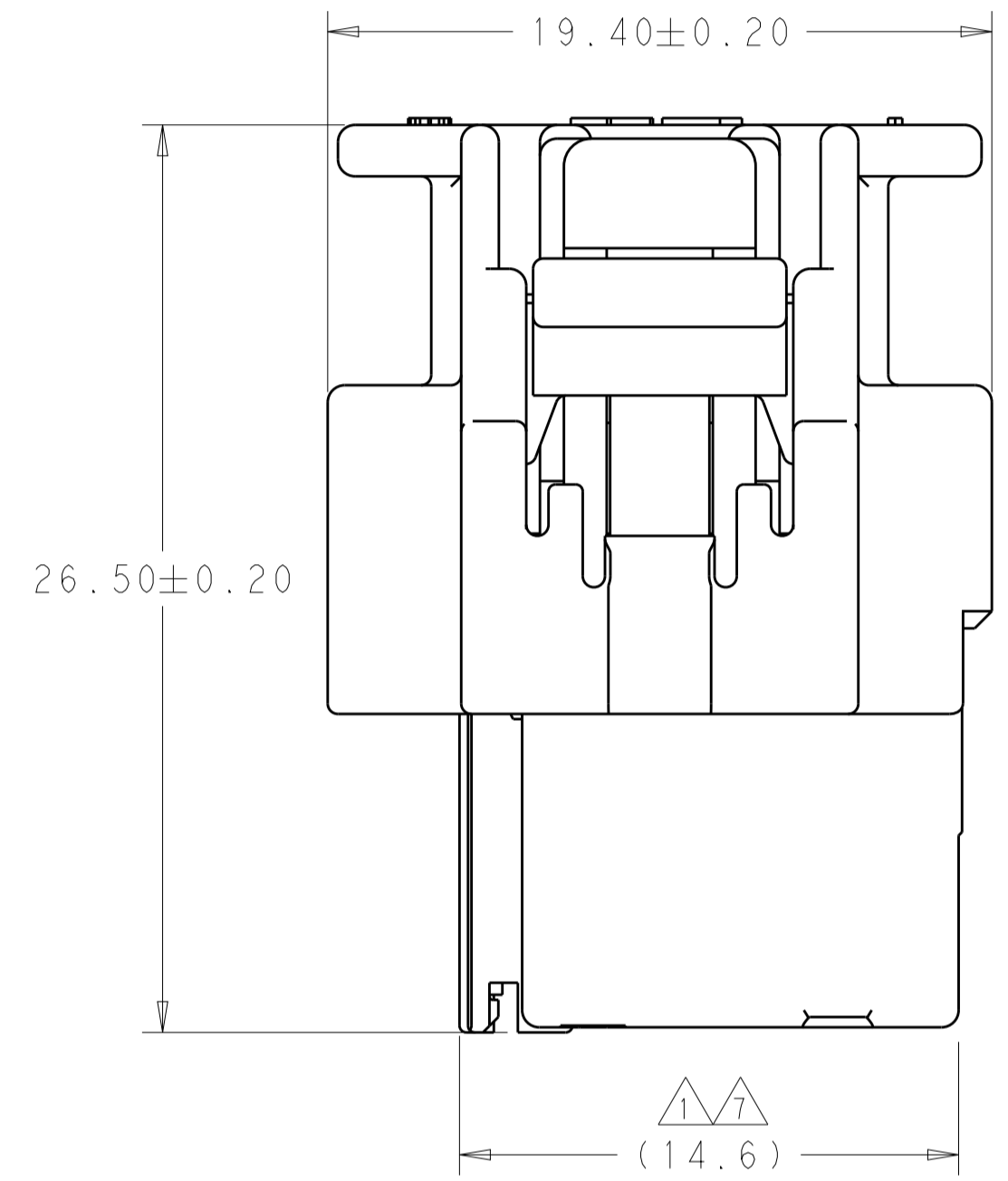
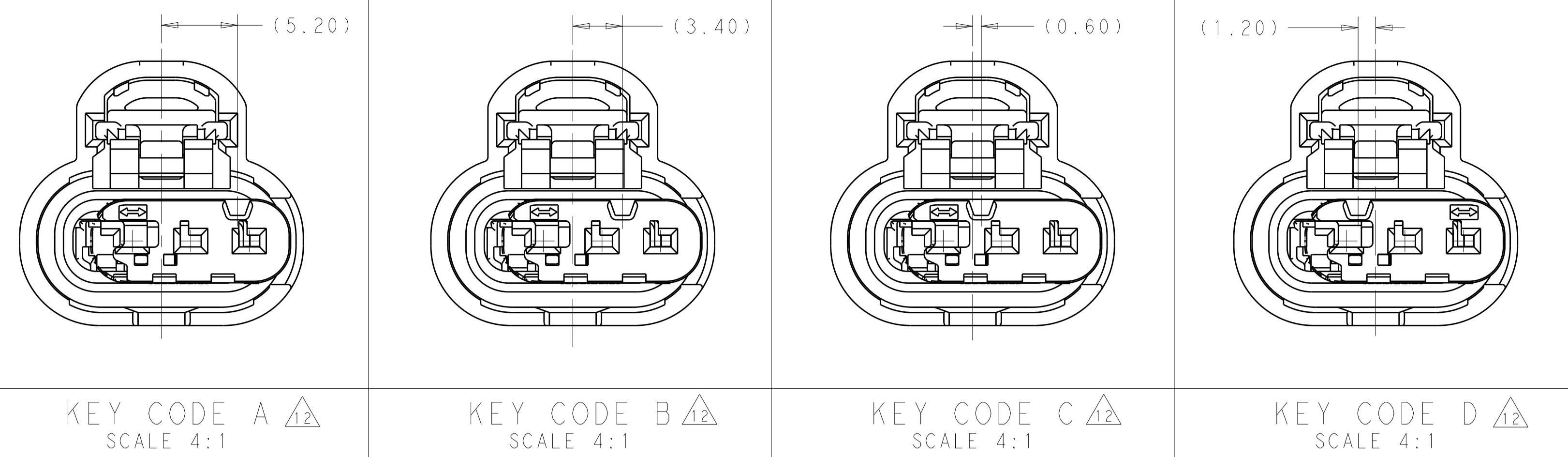

ISL SHOWN IN FINAL (LOCKED) POSITION - REF ONLY SCALE 5:1

ISL SHOWN IN PRE-LATCHED (AS-SHIPED) POSITION

SECTION X-X SHOWN WITH CPA AND ISL IN PRE-LATCHED POSITION

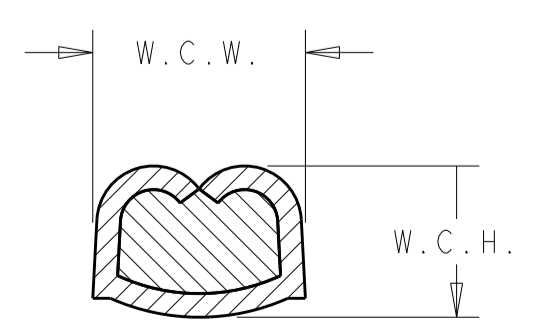

WIRE CRIMP DIMENSIONS

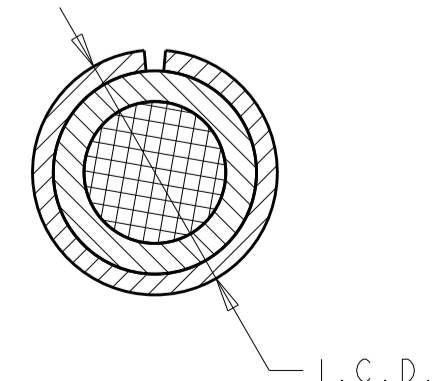

INSULATION CRIMP DIMENSIONS

- 1. ISL AND CPA (WHEN APPLICABLE) ARE SHIPPED IN THEIR PRE-LATCHED POSITIONS.
- 2. TERMINALS SOLD SEPARATELY. FOR USE WITH TE MCON 1.2mm CLEAN BODY CONTACT WITH WIRE SEAL. SEE TABLE.
- 3. APPLICABLE INTERFACE DRAWINGS: EWCAP 120-S-003-1-Z01 AND 120-S-003-1-Z02.
- 4. MINIMUM FEED THROUGH CONDITION WITH 1.0mm CLEARANCE ALL AROUND.
- 5. TRACEABILITY CODE (YY = TWO DIGIT YEAR, JJJ = 3 DIGIT JULIAN DAY, S = 1 DIGIT SHIFT).
- 6. FOR OPTIONAL TERMINAL CAVITY BLOCKING, CONTACT TE SALES REPRESENTATIVE OR CUSTOMER SERVICE.
- 7. SEE INSTRUCTION SHEET 408-32103 FOR CONNECTOR SERVICE AND ISL OPERATION. ISL ACTUATION DISTANCE IS 2.0mm.
- 8. CONTACT PLATING AND APPLICABLE INDIVIDUAL WIRE SEAL ARE APPLICATION DEPENDENT. CONTACT TE SALES REPRESENTATIVE OR CUSTOMER SERVICE FOR DETAILS.
- 9. FOR WIRE CRIMP DETAILS, SEE TE APPLICATION SPECIFICATION 114-18464.
- 10. DOCUMENTED I.C.D. IS SPECIFIED TO MEET MOST WIRE SEAL APPLICATIONS. HOWEVER, I.C.D. IS HIGHLY DEPENDENT ON INSULATION TYPE AND OD. SUFFICIENT GRIP OF THE WIRE SEAL MUST BE OBTAINED SUCH THAT WIRE SEAL DOES NOT DISPLACE FROM INSULATION GRIP DURING CONTACT INSERTION INTO CONNECTOR HOUSING. THE WIRE SEAL SHALL NOT BE CRIMPED TOO TIGHTLY THAT THE WIRE SEAL TEARS DURING THE CRIMPING OPERATION.
- 11. CONNECTOR VALIDATION PER USCAR-2 (REV6) T4,V4,S3 WITH THE FOLLOWING EXCEPTIONS:  
PRIMARY TERMINAL RETENTION FORCE > 25 NEWTONS.
- 12. KEY CODE DIMENSIONS ARE SHOWN WITH ISL IN PRE-LATCHED POSITION. FOR DIMENSION OF KEY WITH ISL IN FINAL POSITION, ADJUST SHOWN DIMENSIONS BY 2.0mm.
- 13. NOTE REMOVED
- 14. NOTE REMOVED

ISL	ISL COLOR	KEY CONFIGURATION	PART NUMBER
YES	BLUE	KEY CODE D	1-2203771-4
	DK GRAY	KEY CODE C	1-2203771-3
	LT GRAY	KEY CODE B	1-2203771-2
NO	BLUE	KEY CODE A	1-2203771-1
	DK GRAY	KEY CODE C	2203771-3
	LT GRAY	KEY CODE B	2203771-2
CPA (YES/NO)	ISL COLOR	KEY CONFIGURATION	PART NUMBER

MAX TEMP	FEMALE TERMINAL P/N	W.C.H	W.C.W	I.C.D	WIRE SEAL PART NUMBER
150°C	1418844				
	1670146				
	1418850				

THIS DRAWING IS A CONTROLLED DOCUMENT. DWG: VISHGNUM.P 30MAY2013  
 CHK: MD BROWN 30MAY2013  
 APVD: MD BROWN 30MAY2013

**STE** TE Connectivity

NAME: PLUG ASSEMBLY, SEALED, 3 POSITION, MCON

SIZE: A1 CAGE CODE: 2203771 DRAWING NO: 2203771-1 SHEET 1 OF 1 REV C

RESTRICTED TO CUSTOMER DRAWING

## X-ON Electronics

Largest Supplier of Electrical and Electronic Components

*Click to view similar products for [Automotive Connectors](#) category:*

*Click to view products by [TE Connectivity](#) manufacturer:*

Other Similar products are found below :

[003-018-000](#) [60993906-B](#) [M902-2131](#) [M902-2161](#) [M902-2344](#) [72.330.1035.1](#) [73.353.4028.0](#) [F166900](#) [F358300-B](#) [F407400](#) [776880-1](#)  
[827153-1](#) [8N1515-32-24P](#) [9-1326729-8](#) [925474-1](#) [928905-1](#) [964562-4](#) [968782-1](#) [98891-1012](#) [12004475-L](#) [12020308](#) [12041318-B](#)  
[12052466](#) [12064869](#) [12015909](#) [1-21030-1](#) [12041254](#) [12041318](#) [12047946-B](#) [12047957](#) [12110546-B](#) [12131792](#) [12092346](#) [HD34-18-14PT](#)  
[HD46-24-23SN-059](#) [HDB36-24-16PN-059](#) [HDP26-24-9SE-L015](#) [12185550](#) [12336-12](#) [12147304](#) [12191172-B](#) [12S](#) [13545280](#) [13577943](#)  
[13681974](#) [13737722-B](#) [13755420](#) [13783086](#) [13830674](#) [13832576](#)