

LOC	DIST	REVISIONS			
P	LTN	DESCRIPTION	DATE	DWN	APVD
GP	00	A	RELEASED FOR PRODUCTION	29FEB2016	TX SH

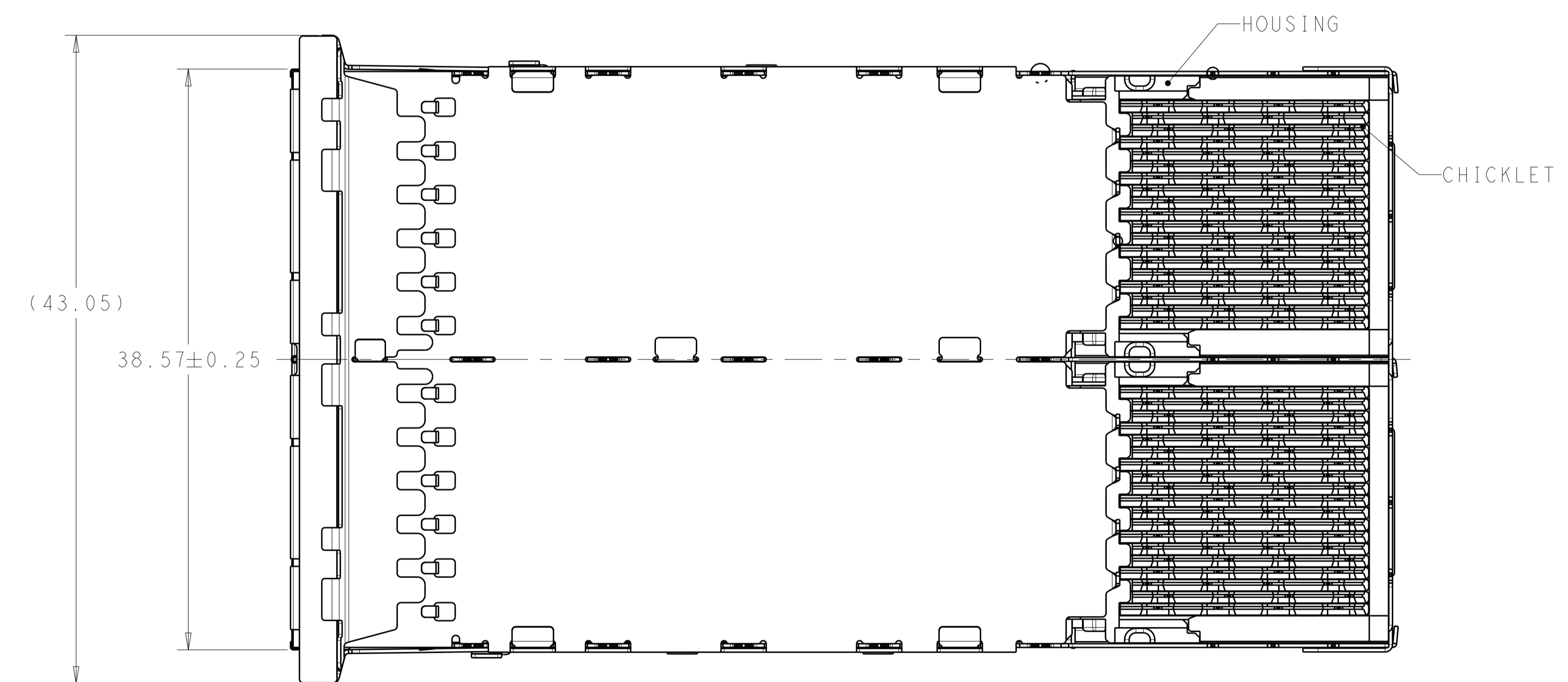
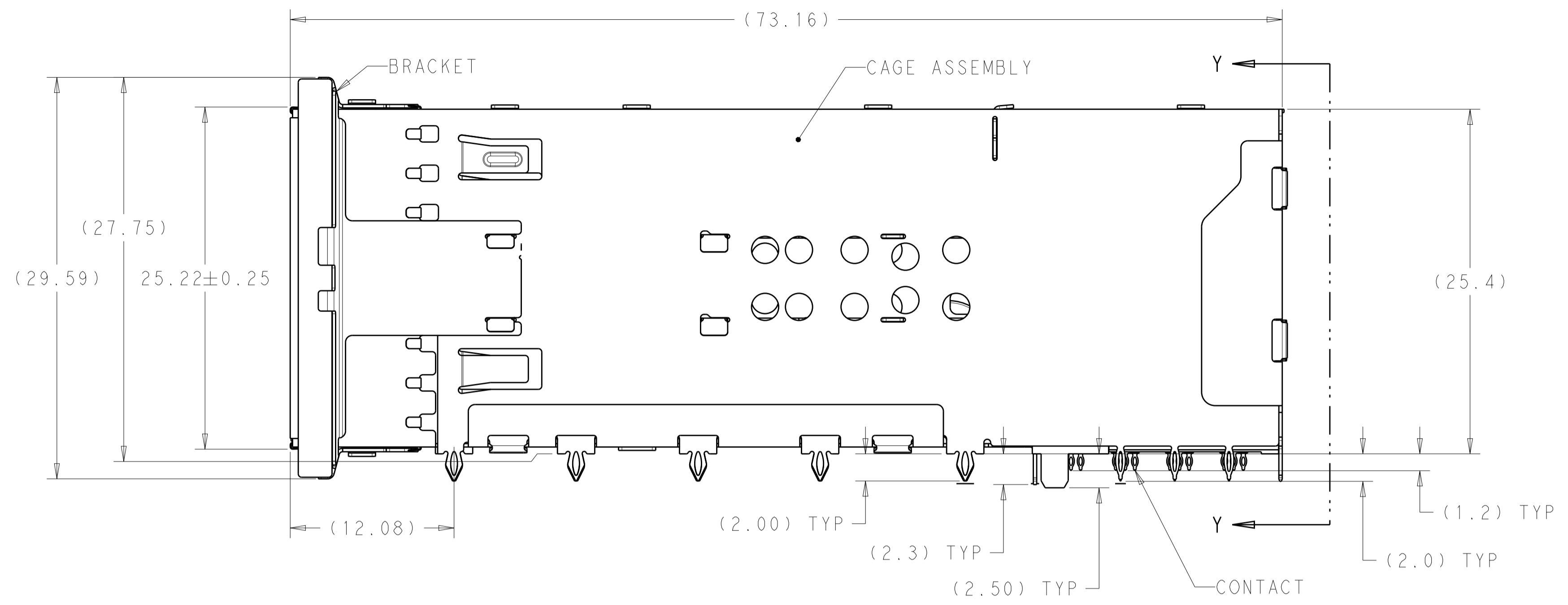
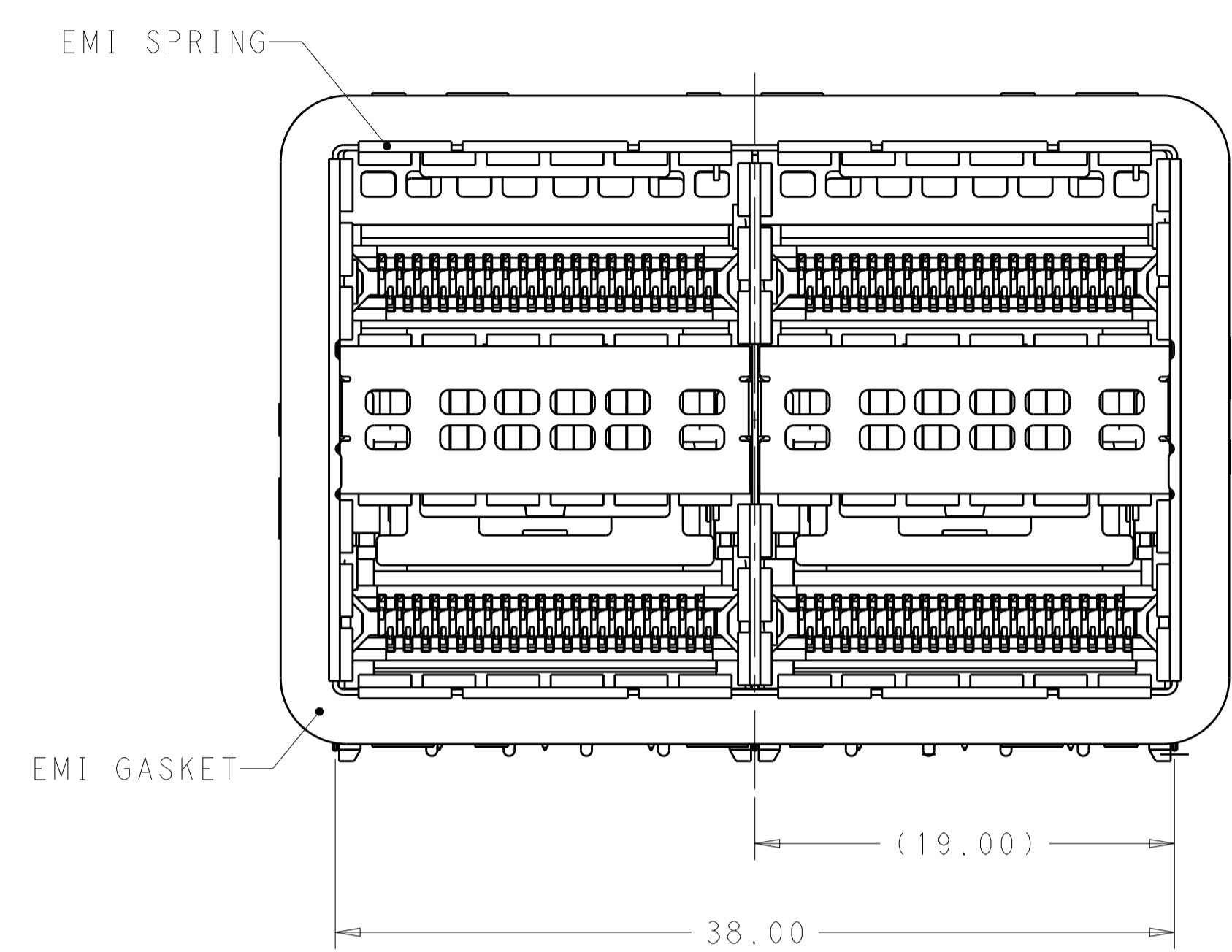

- MATERIALS:
 CAGE ASSEMBLY- NICKEL SILVER ALLOY PER ASTM B 122.
 BRACKET- NICKEL SILVER ALLOY PER ASTM B 122.
 EMI SPRING- COPPER ALLOY, NICKEL PLATED.
 EMI GASKET- PLATED FILLED SILICONE WITH 94V-0.
 HOUSING- POLYESTER LCP WITH 94V-0.
 CHICKLET- POLYESTER LCP WITH 94V-0.
 CONTACT- COPPER ALLOY.
 LIGHTPIPE- POLYCARBONATE WITH 94V-0.

- CONTACT FINISH: 0.76µm GOLD ON MATING END, 1.25µm MATT TIN ON SOLDER TAIL, ALL OVER 1.27µm NICKEL.
- DATUM AND BASIC DIMENSION ESTABLISHED BY CUSTOMER.
- MINIMUM PCB THICKNESS OF 1.57.
- THE ENTIRE AREA OF THE CONNECTOR FOOTPRINT, INDICATED BY THE DASHED LINE, TO BE CONSIDERED THE KEEPOUT AREA FOR COMPONENTS.
- CROSS-HATCHED AREAS REPRESENT ZONES ON THE PCB THAT COME IN CONTACT WITH OR BE IN CLOSE PROXIMITY TO THE PLASTIC HOUSING OR THE CONNECTOR CAGE. INDICATED AREAS TO BE CONSIDERED TRACE FREE.
- PART NUMBER AND DATE CODE MADE IN APPROXIMATE AREA SHOWN.
- HATCHED AREA IS PLACEMENT ZONE FOR LED. LED SHOULD BE CENTERED WITHIN ZONE. RECOMMEND 0805 PACKAGE.
- CONTACT FINISH: 0.08µm MINIMUM GOLD OVER 0.68µm PALLADIUM-NICKEL ON MATING END, 1.25µm MATT TIN ON SOLDER TAIL, ALL OVER 1.27µm NICKEL.

CONTACT FINISH	DESCRIPTION	PART NUMBER
9	LEFT INDICATOR DOWN	2214593-6
9	LEFT INDICATOR UP	2214593-5
9	NO LIGHTPIPE	2214593-4
2	LEFT INDICATOR DOWN	2214593-3
2	LEFT INDICATOR UP	2214593-2
2	NO LIGHTPIPE	2214593-1

THIS DRAWING IS A CONTROLLED DOCUMENT. DIMENSIONING AND TOLERANCING PER ASME Y14.5M-2009. TOLERANCES UNLESS OTHERWISE SPECIFIED:

DIMENSIONS:	mm	0 PLC ±0.25	1 PLC ±0.15	2 PLC ±0.10	3 PLC ±0.05	4 PLC ±0.02	ANGLES ±0.1	FINISH ±0.05
-------------	----	-------------	-------------	-------------	-------------	-------------	-------------	--------------

MATERIAL: SEE NOTE 1
 FINISH: SEE NOTE 2

DWN: M. SHIRK 24FEB2012	CHK: D. SZCZESNY 24FEB2012	APVD: -
PRODUCT SPEC: 108-60102	APPLICATION SPEC: 114-60015	WEIGHT: -
NAME: CAGE AND CONNECTOR ASSEMBLY, WITH EMI GASKET, 2X2, ZQSFP+ STACKED		RESTRICTED TO: -
SIZE: A1	CAGE CODE: 100779	DRAWING NO: 2214593
CUSTOMER DRAWING	SCALE: 4:1	SHEET 1 OF 4 REV A

LOC		DIST		REVISIONS			
P	LTN	DESCRIPTION	DATE	DWN	APVD		
-	-	SEE SHEET 1	-	-	-		

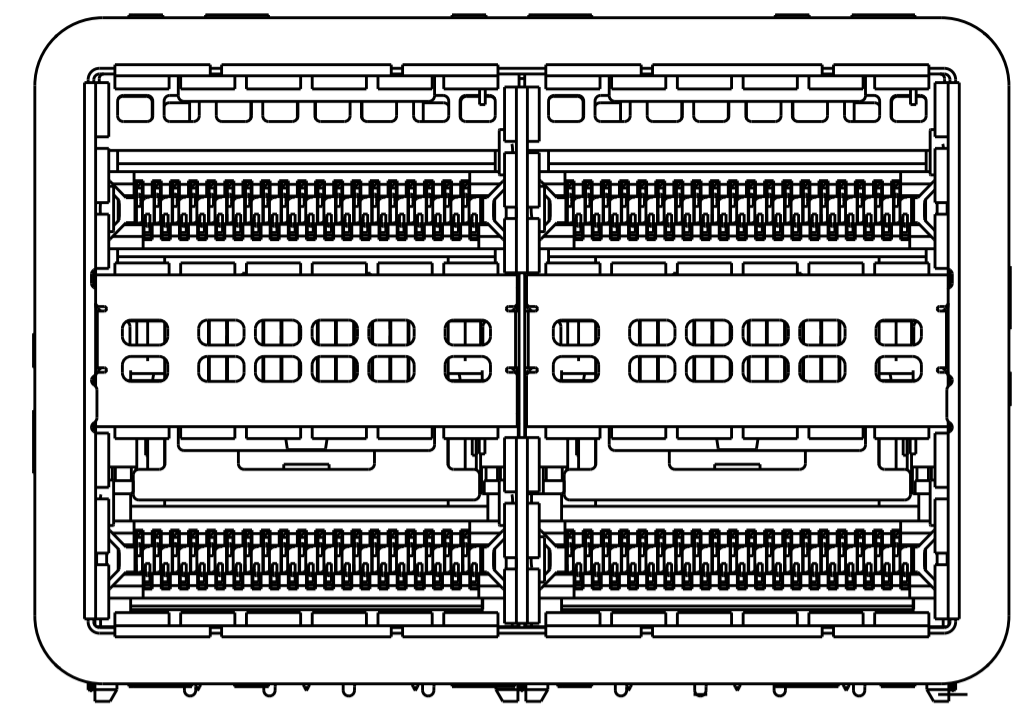

2214593-1 / 2214593-4
 NO LIGHTPIPE IN ASSEMBLY
 SCALE 3:1

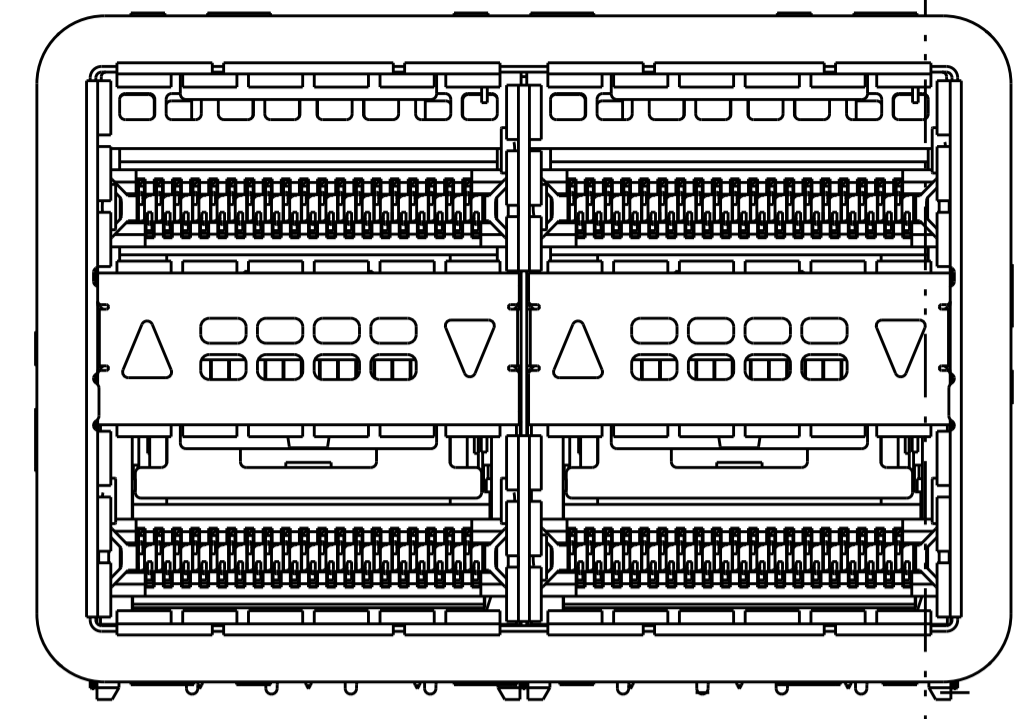

2214593-2 / 2214593-5
 LEFT LIGHTPIPE INDICATOR
 POINTING TO UPPER PORT
 SCALE 3:1

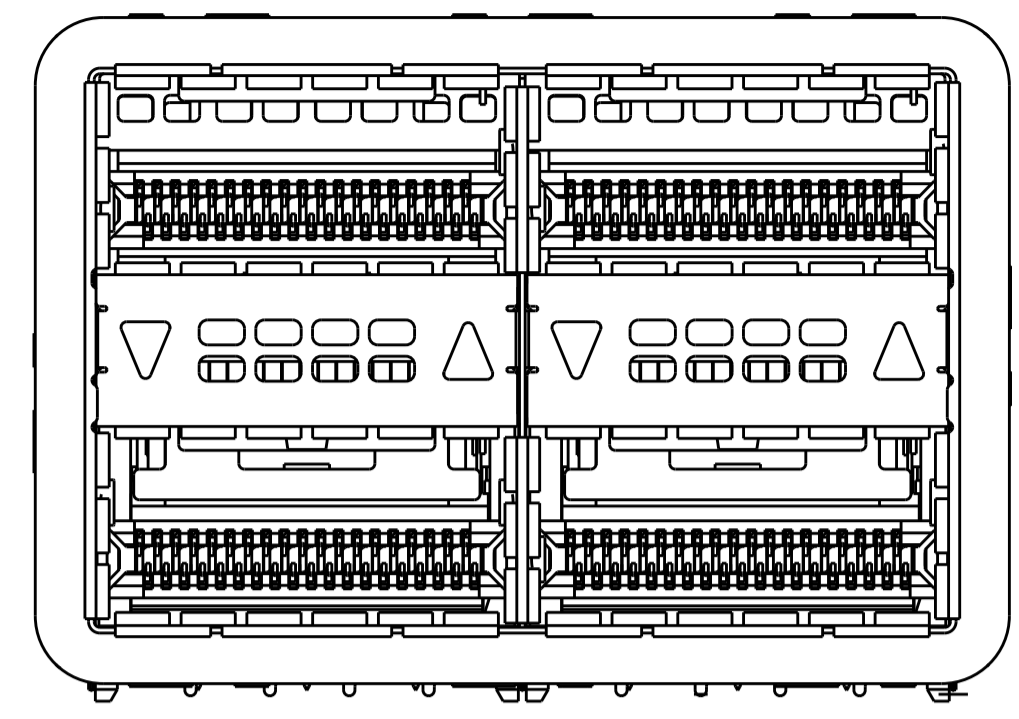

2214593-3 / 2214593-6
 LEFT LIGHTPIPE INDICATOR
 POINTING TO LOWER PORT
 SCALE 3:1

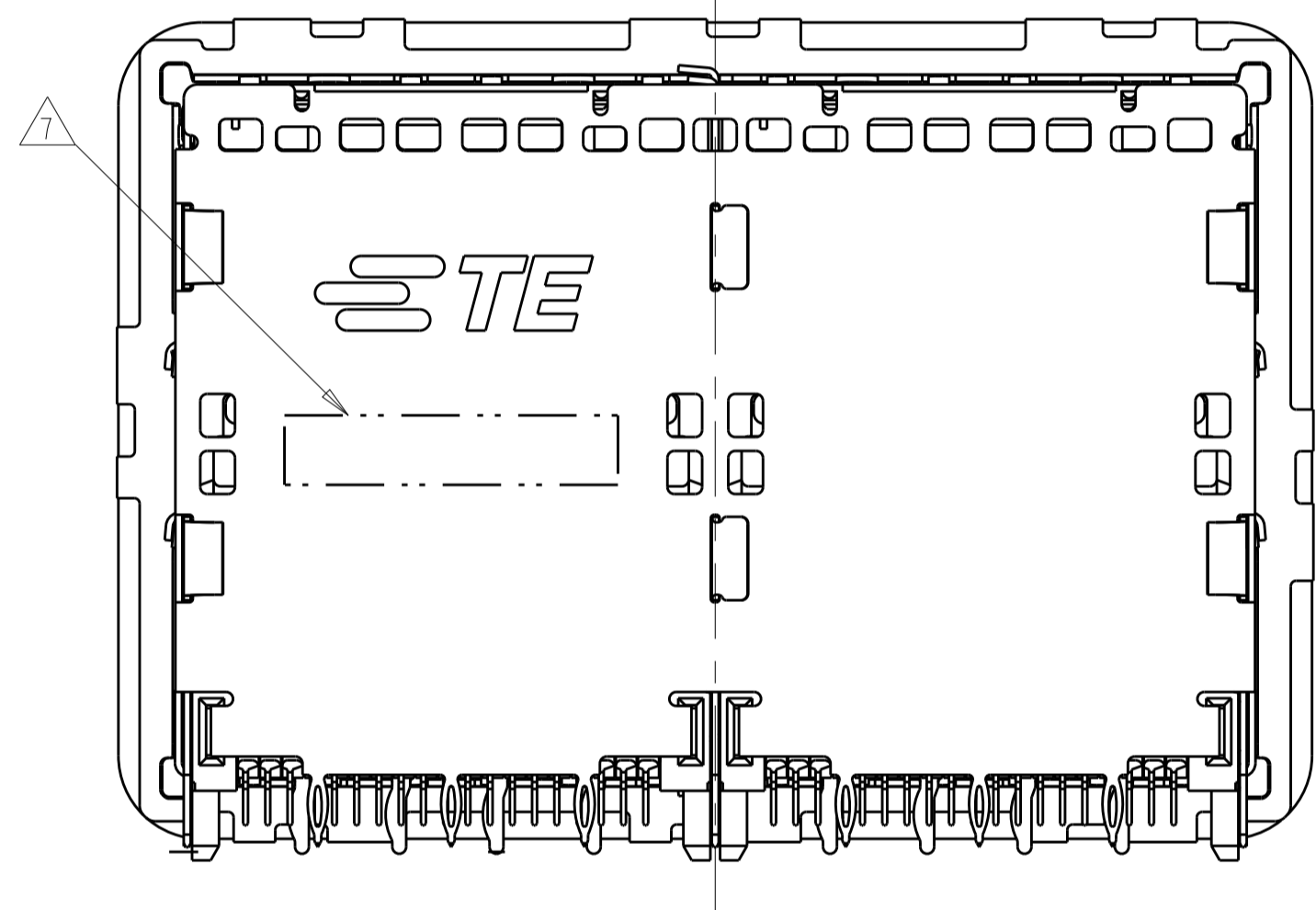

VIEW Y-Y

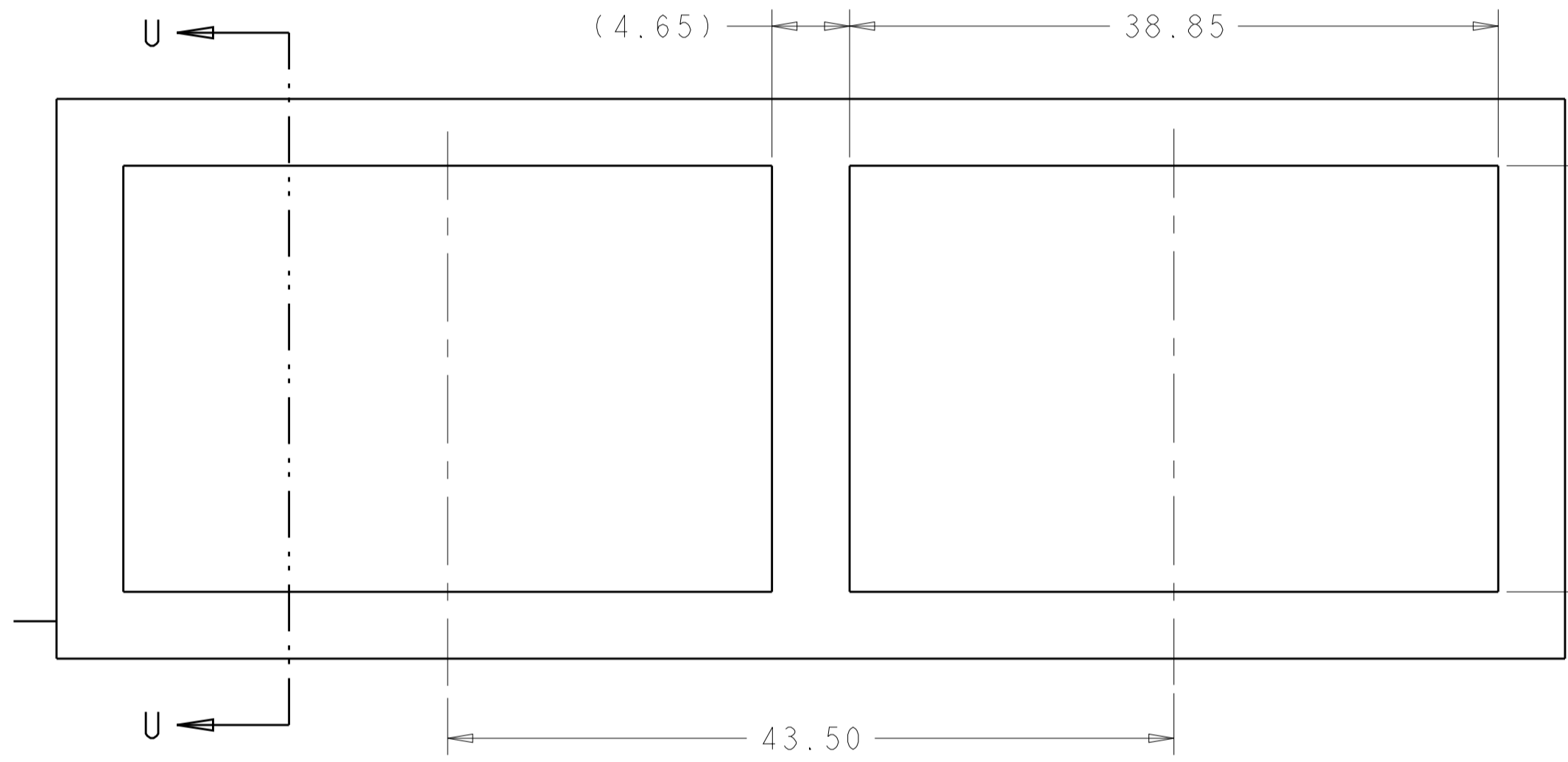

RECOMMENDED PANEL CUTOUT
 AND PC BOARD, PANEL POSITION
 SCALE 3:1

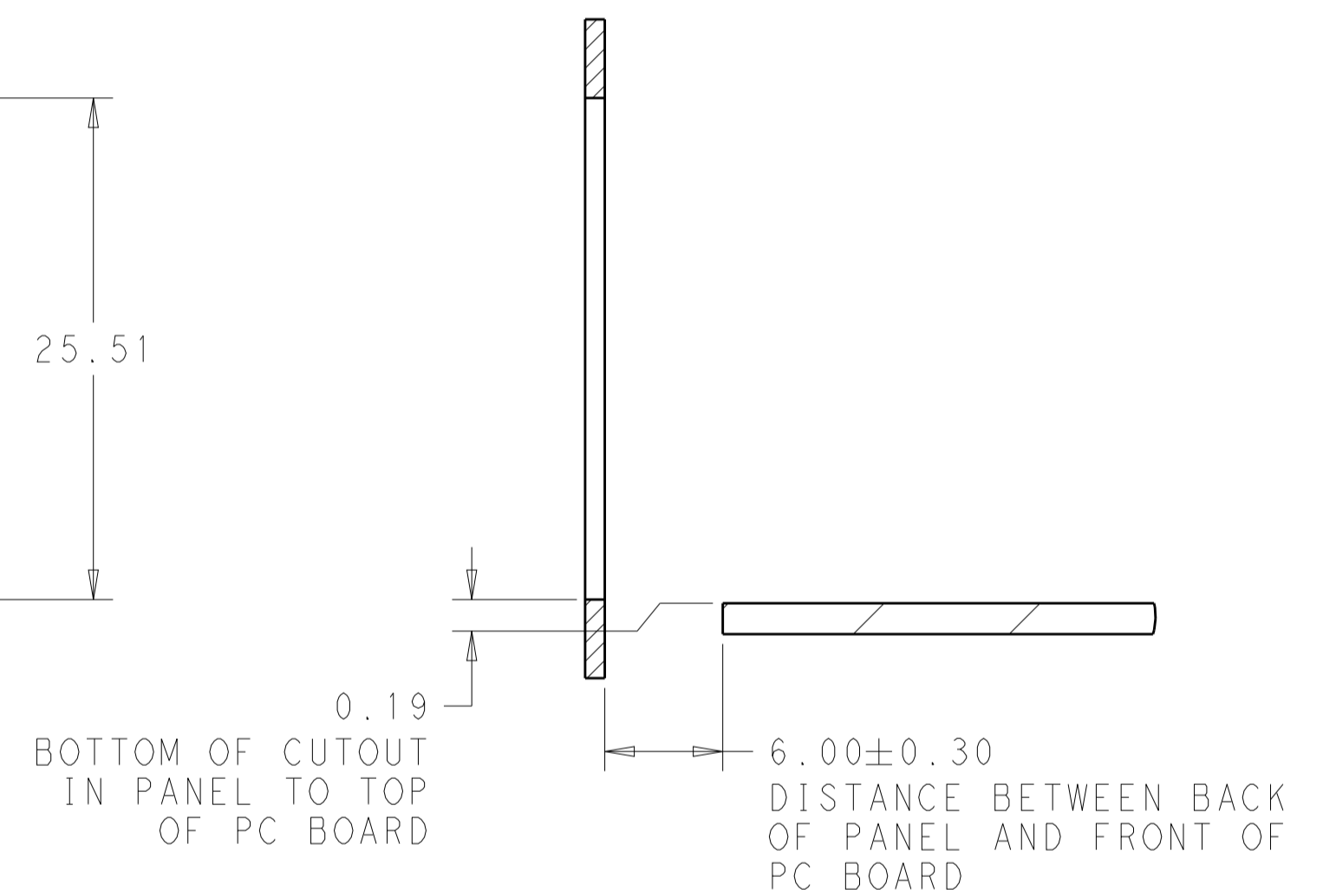

SECTION U-U

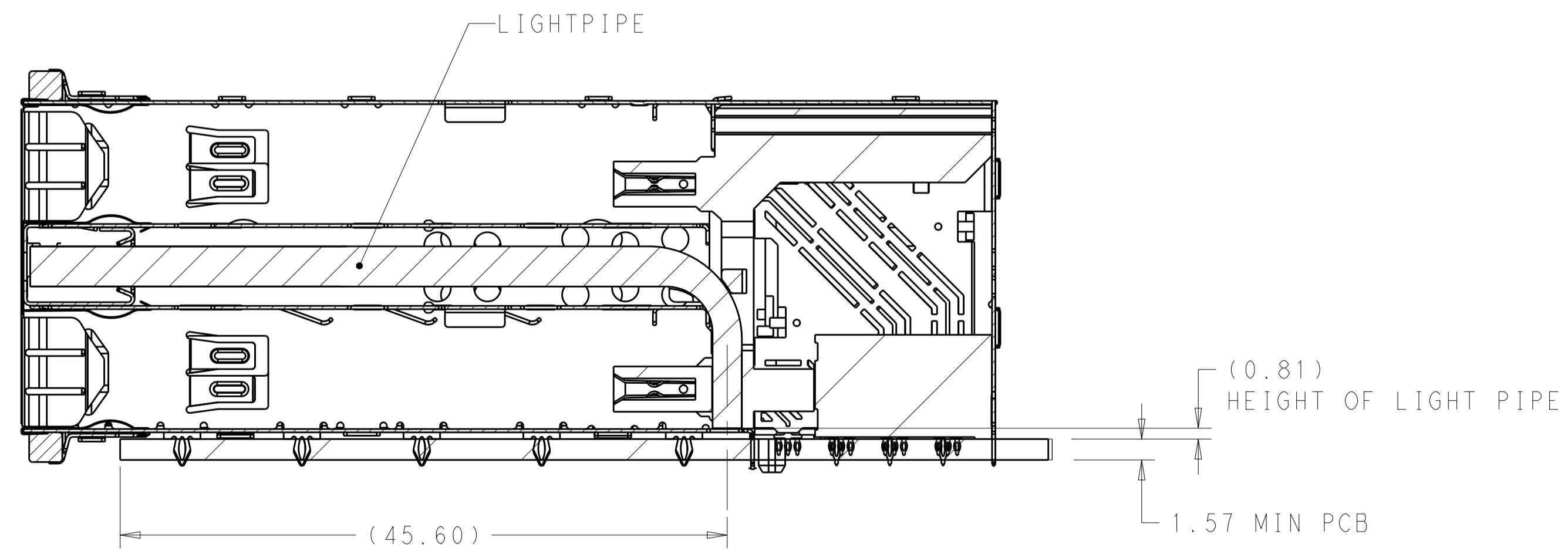

SECTION V-V
 SCALE 3:1

THIS DRAWING IS A CONTROLLED DOCUMENT. DIMENSIONING AND TOLERANCING PER ASME Y14.5M-2009		DWN: M. SHIRK 24FEB2012 CHK: D. SZCZESNY 24FEB2012	TE Connectivity NAME: CAGE AND CONNECTOR ASSEMBLY, WITH EMI GASKET, 2X2, ZQSFP+ STACKED
DIMENSIONS: mm		APVD: -	
TOLERANCES UNLESS OTHERWISE SPECIFIED: 0 PLC ± 1 PLC ±0.25 2 PLC ±0.15 3 PLC ± 4 PLC ± ANGLES ±		PRODUCT SPEC: 108-60102 APPLICATION SPEC: 114-60015	RESTRICTED TO: -
MATERIAL: SEE NOTE 1	FINISH: SEE NOTE 2	WEIGHT: -	SIZE: A1 CAGE CODE: 00779 DRAWING NO: C=2214593
CUSTOMER DRAWING		SCALE: 4:1	SHEET: 2 OF 4 REV: A

LOC		DIST		REVISIONS			
P	LTN	DESCRIPTION	DATE	DMN	APVD		
-	-	SEE SHEET 1	-	-	-	-	-

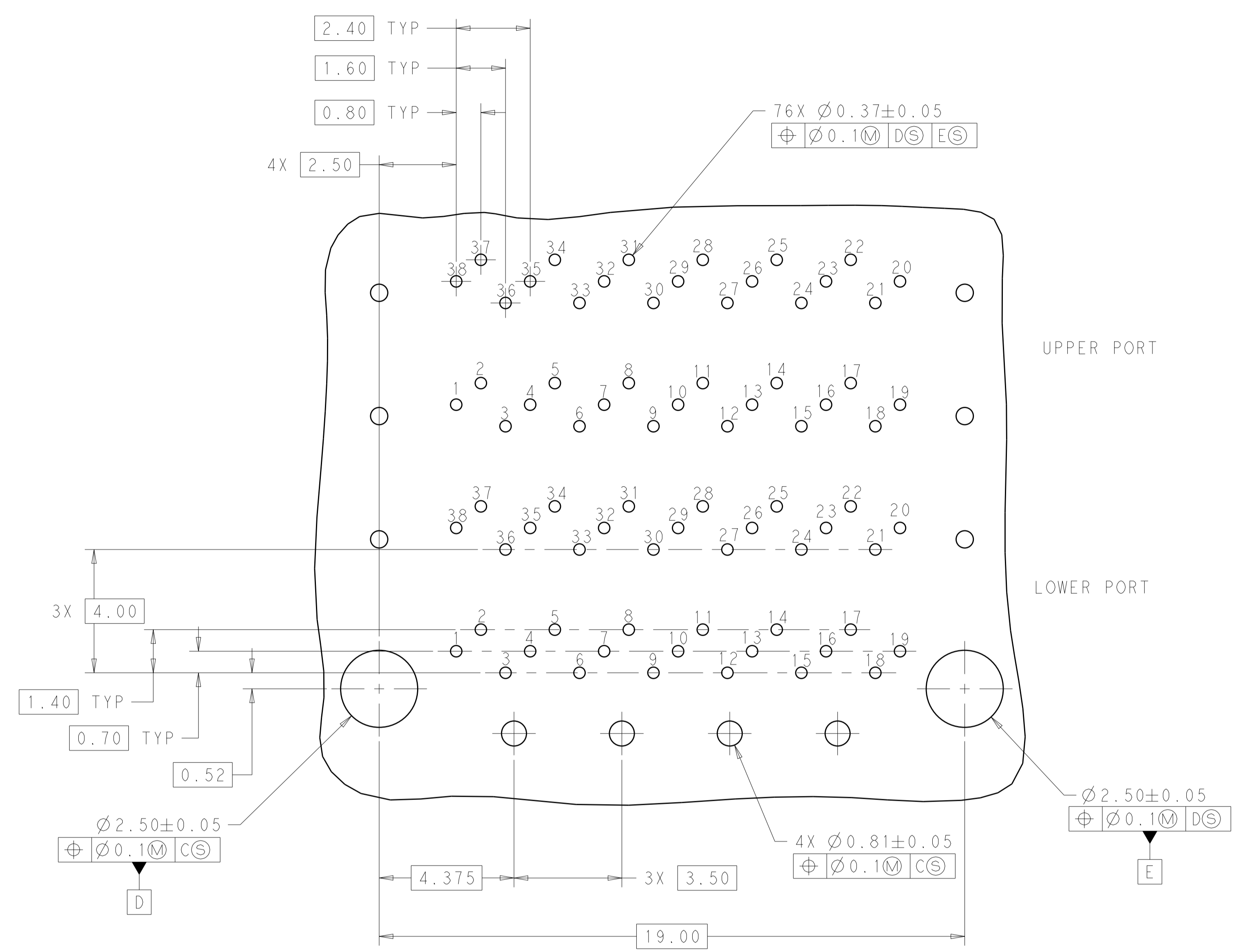
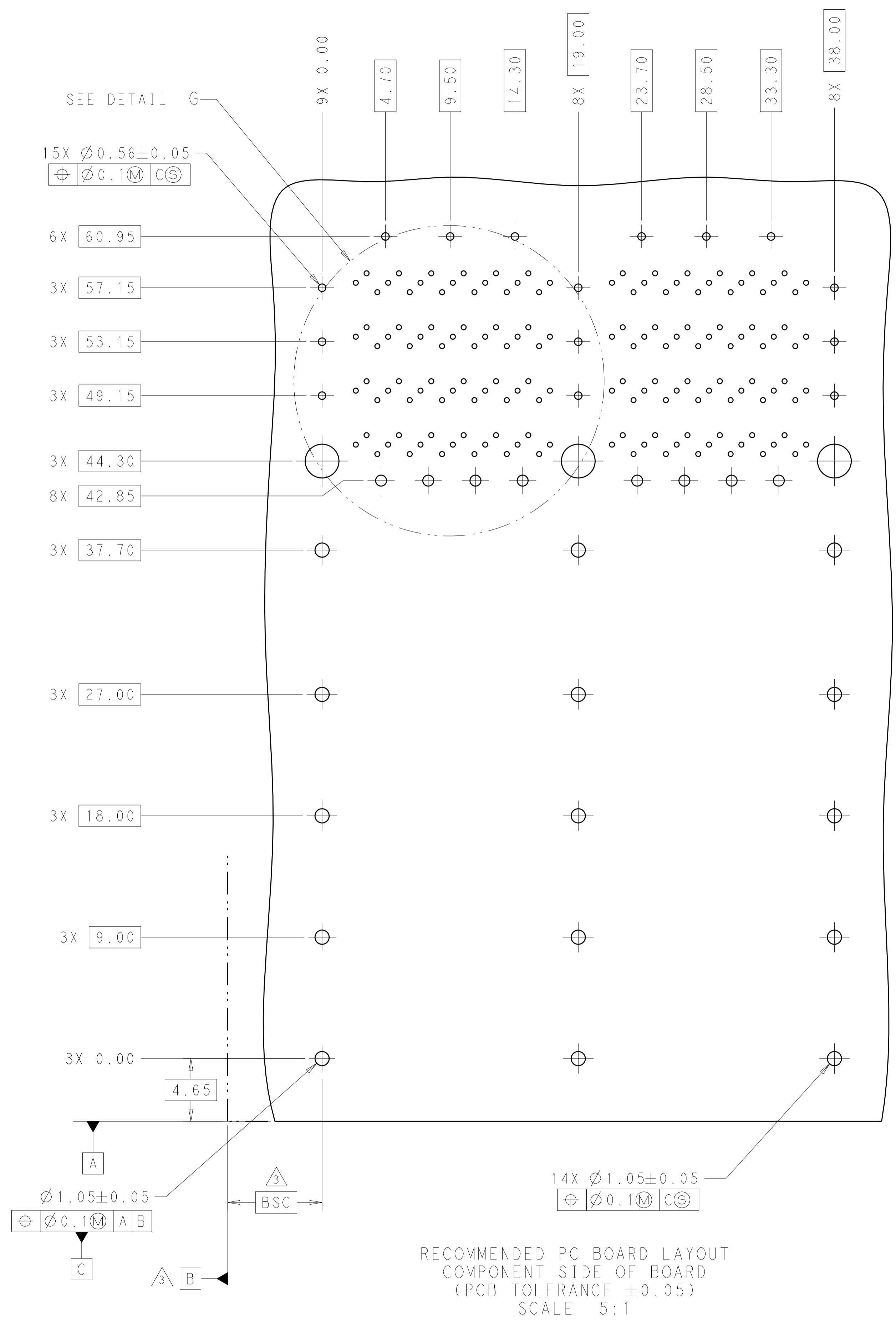

THIS DRAWING IS A CONTROLLED DOCUMENT. DIMENSIONING AND TOLERANCING PER ASME Y14.5M-2009		DMN: M. SHIRK 24FEB2012 CHK: D. SZCZESNY 24FEB2012	TE Connectivity	
DIMENSIONS: mm	TOLERANCES UNLESS OTHERWISE SPECIFIED:	APVD: -	NAME: CAGE AND CONNECTOR ASSEMBLY, WITH EMI GASKET, 2X2, ZQSFP+ STACKED	
0 PLC \pm	1 PLC ± 0.25	PRODUCT SPEC: 108-60102	SIZE: 114-60015	
2 PLC ± 0.15	3 PLC \pm	APPLICATION SPEC: 114-60015	RESTRICTED TO: -	
4 PLC \pm	ANGLES \pm	WEIGHT: -	A100779C=2214593	
MATERIAL: -	FINISH: -	CUSTOMER DRAWING	SCALE: 4:1	SHEET 3 OF 4 REV A

LOC		DIST		REVISIONS			
P.	LTN.	DESCRIPTION	DATE	DWN.	APVD.		
-	-	SEE SHEET 1	-	-	-		

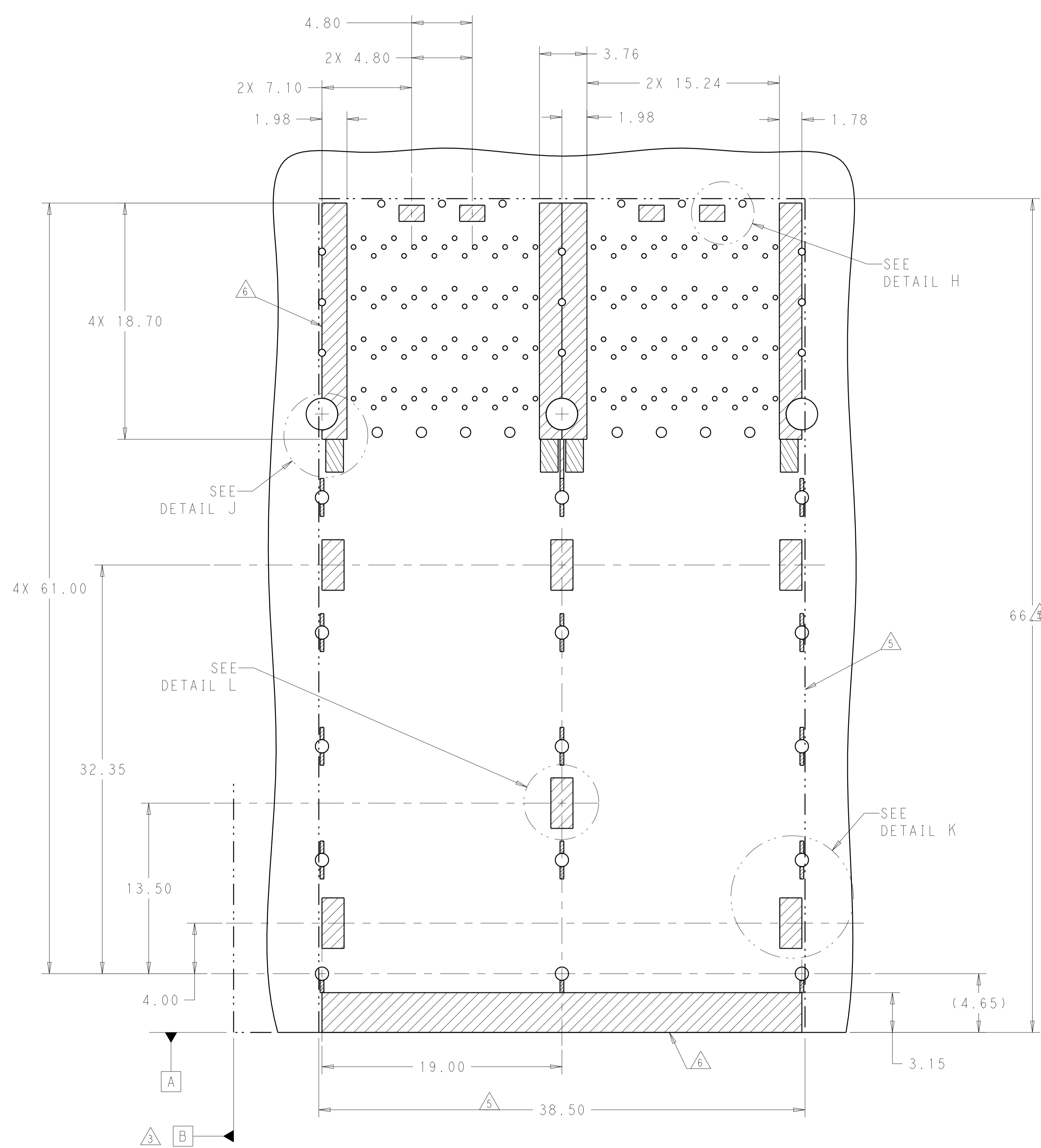

KEEPOUT AREAS
 COMPONENT SIDE OF BOARD
 SCALE 5:1

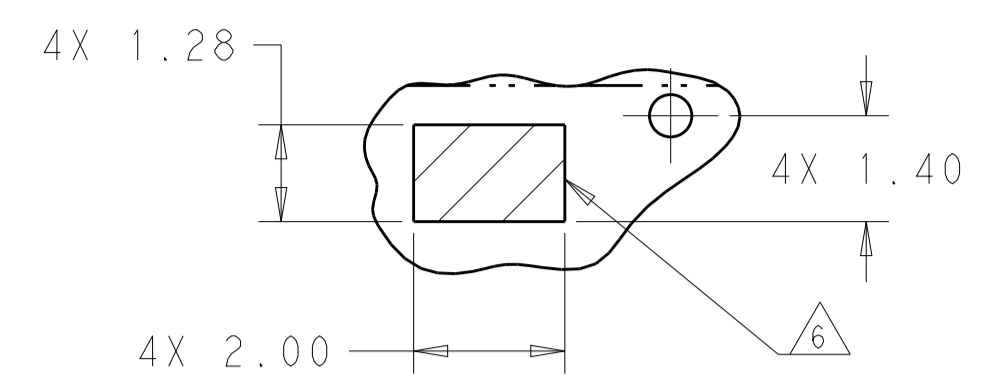

DETAIL H
 SCALE 10:1

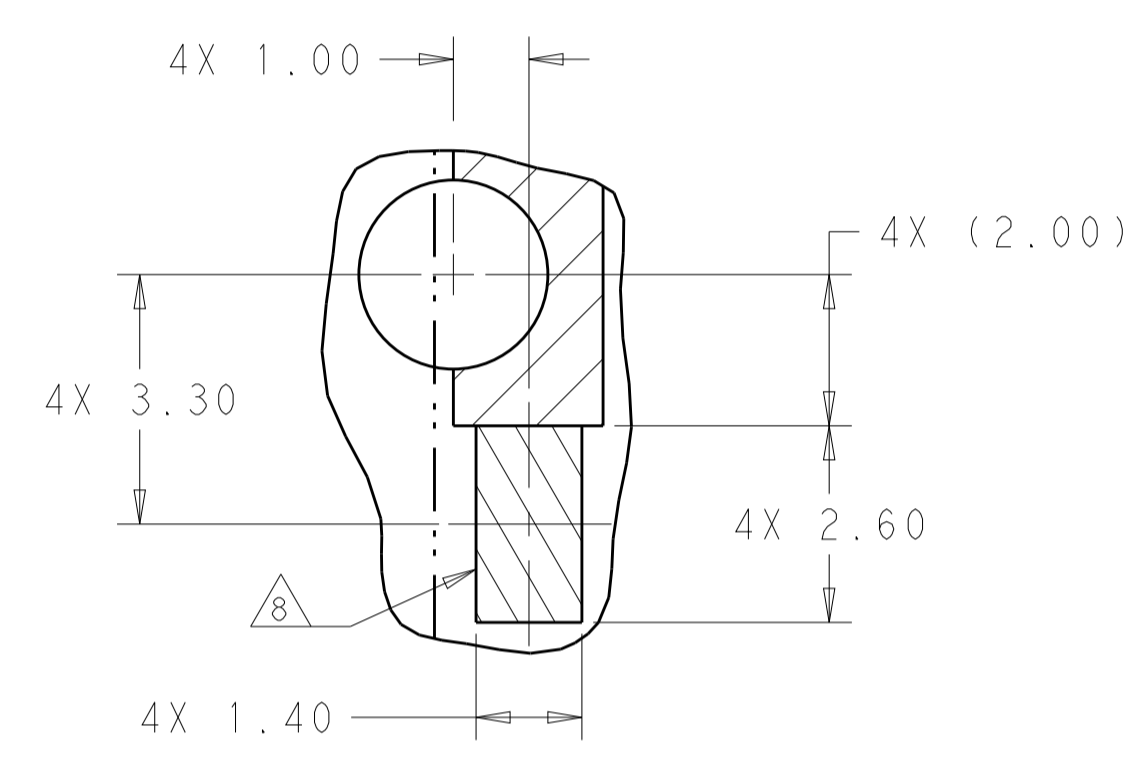

DETAIL J
 LED PADS
 SCALE 10:1

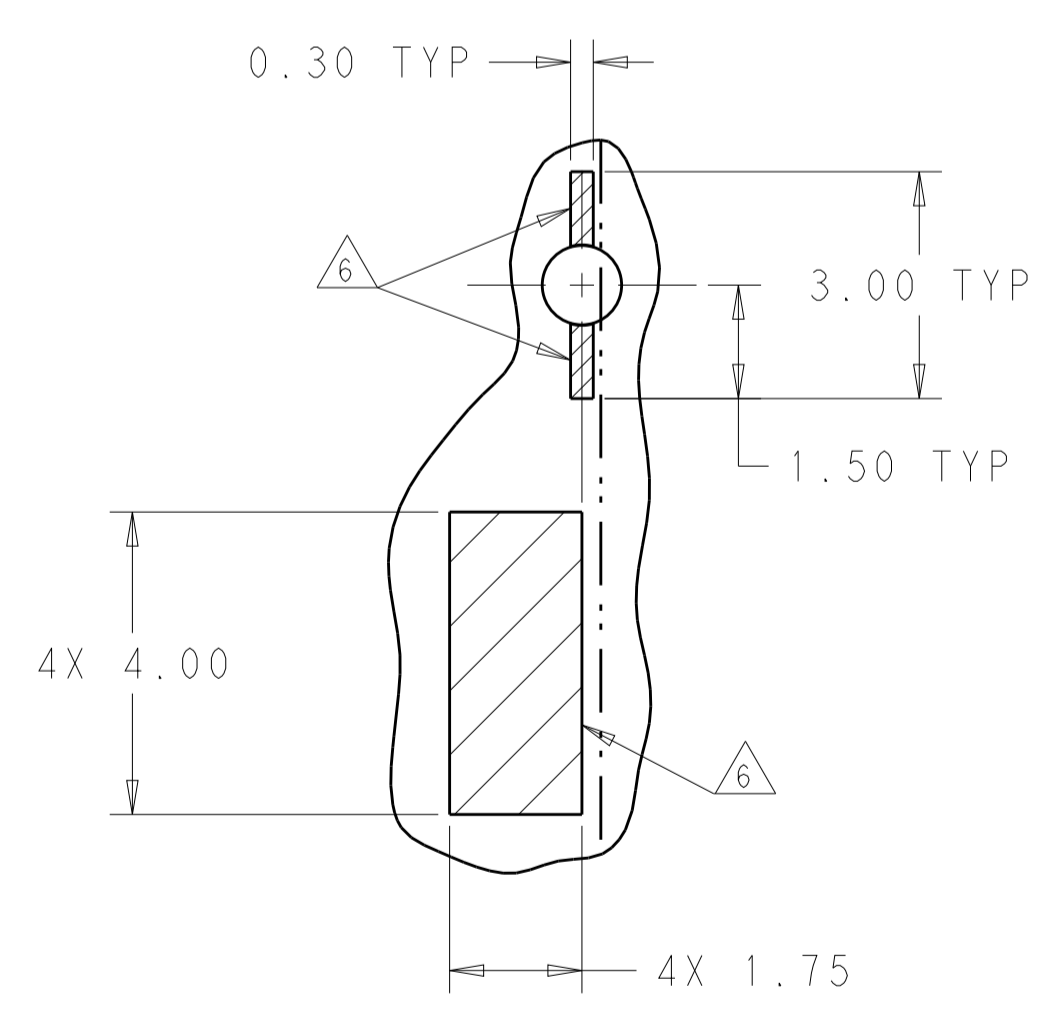

DETAIL K
 SCALE 10:1

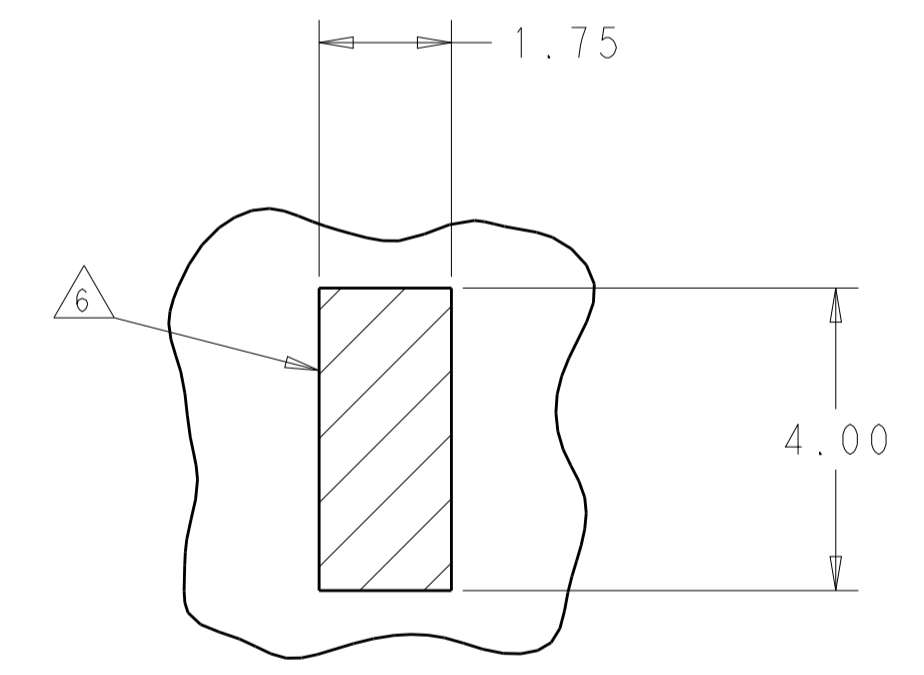

DETAIL L
 SCALE 10:1

THIS DRAWING IS A CONTROLLED DOCUMENT. DIMENSIONING AND TOLERANCING PER ASME Y14.5M-2009.		DWN: M. SHIRK 24FEB2012 CHK: D. SZCZESNY 24FEB2012	TE Connectivity	
DIMENSIONS: mm	TOLERANCES UNLESS OTHERWISE SPECIFIED:	APVD: -	NAME: CAGE AND CONNECTOR ASSEMBLY, WITH EMI GASKET, 2X2, ZQSFP+ STACKED	RESTRICTED TO: -
0 PLC ±0.25	1 PLC ±0.15	PRODUCT SPEC: 108-60102	SIZE: 114-60015	SCALE: 4:1
2 PLC ±0.15	3 PLC ±0.15	APPLICATION SPEC: -	WEIGHT: -	SHEET: 4 OF 4
4 PLC ±0.15	ANGLES ±0.15	FINISH: -	CUSTOMER DRAWING	REV: A
MATERIAL: -	FINISH: -	SEE NOTE 1	SEE NOTE 2	

X-ON Electronics

Largest Supplier of Electrical and Electronic Components

Click to view similar products for [I/O Connectors](#) category:

Click to view products by [TE Connectivity](#) manufacturer:

Other Similar products are found below :

[571763P](#) [58098-0628](#) [72.250.1628.2](#) [72.250.2428.2](#) [74720-0505](#) [76.350.0729.0](#) [76871-1403](#) [FCN-244F080-G/1](#) [FCN-260A9920](#) [PCR-E36PM](#) [PCS-XE26MA+](#) [G38A71314B](#) [1571250010](#) [157-22500-3](#) [MS3471L14-19P L/C](#) [172501-4002](#) [172501-6002](#) [FCN-260C008-A/L0](#) [FCN-260C024-AL0](#) [FCN-261Z008](#) [2000314-1](#) [200331-1](#) [PCR-E36FC+](#) [PCS-E28FS+](#) [PCS-XE26SLFD+](#) [PCS-XE26SLFDT+](#) [G730VID08BDC24](#) [U90B2054081210](#) [38113800006](#) [DP3AR020WQ1R200](#) [Z4.102.0680.0](#) [500-1040](#) [500-1052](#) [500-1054](#) [ZP-4008-66L](#) [0709821002](#) [DX40-20P\(55\)](#) [5554841-1](#) [MS3474W18-8P-LC*](#) [U90B3054061110](#) [U65-E04-4020](#) [ZPF000000000097891](#) [747360449](#) [10099439-003C-TRLF](#) [10137239-0021LF](#) [E9320-001-01](#) [10137239-0011LF](#) [70289-001LF](#) [70.060.1028.0](#) [109029-ZZ](#)