

222A142-3/42-0 ✓ ACTIVE

Raychem

TE Internal #: 814717N003

Heat Shrink Boots, 90 °, Molded Part Shape Code 222, 3, 10,
Adhesive Pre-Coat, Operating Temperature Range -55 – 135 °C
[-67 – 275 °F]

[View on TE.com >](#)



Wire Protection & Management > Heat Shrink Molded Shapes > Heat Shrink Boots > Heat Shrink Boots: Non Lipped, Right Angle



Molded Part Angle: 90 °

Molded Part Shape Code: 222

Lipped: No

Material Code: 3

Heat Shrink Boot Material Systems Code: 10

[All Heat Shrink Boots: Non Lipped, Right Angle \(136\)](#)

Features

Product Type Features

Molded Part Angle	90 °
-------------------	------

Configuration Features

Lipped	No
--------	----

Body Features

Material Code	3
Heat Shrink Boot Material Systems Code	10
Adhesive Pre-Coat	Yes
Material	Semi-Rigid Modified Polyolefin

Usage Conditions

Operating Temperature Range	-55 – 135 °C[-67 – 275 °F]
Flammability	Flame-Retardant

Other

Molded Part Shape Code	222
Fluid & Chemical Resistance	Occasional exposure to fluids

Product Compliance

[For compliance documentation, visit the product page on TE.com>](#)

EU RoHS Directive 2011/65/EU	Compliant
EU ELV Directive 2000/53/EC	Compliant
China RoHS 2 Directive MIIT Order No 32, 2016	No Restricted Materials Above Threshold
EU REACH Regulation (EC) No. 1907/2006	Current ECHA Candidate List: JAN 2021 (211) Candidate List Declared Against: JAN 2021 (211) Does not contain REACH SVHC
Halogen Content	Not Low Halogen - contains Br or Cl > 900 ppm.
Solder Process Capability	Not applicable for solder process capability

Product Compliance Disclaimer

This information is provided based on reasonable inquiry of our suppliers and represents our current actual knowledge based on the information they provided. This information is subject to change. The part numbers that TE has identified as EU RoHS compliant have a maximum concentration of 0.1% by weight in homogenous materials for lead, hexavalent chromium, mercury, PBB, PBDE, DBP, BBP, DEHP, DIBP, and 0.01% for cadmium, or qualify for an exemption to these limits as defined in the Annexes of Directive 2011/65/EU (RoHS2). Finished electrical and electronic equipment products will be CE marked as required by Directive 2011/65/EU. Components may not be CE marked. Additionally, the part numbers that TE has identified as EU ELV compliant have a maximum concentration of 0.1% by weight in homogenous materials for lead, hexavalent chromium, and mercury, and 0.01% for cadmium, or qualify for an exemption to these limits as defined in the Annexes of Directive 2000/53/EC (ELV). Regarding the REACH Regulation, the information TE provides on SVHC in articles for this part number is based on the latest European Chemicals Agency (ECHA) 'Guidance on requirements for substances in articles' posted at this URL: <https://echa.europa.eu/guidance-documents/guidance-on-reach>

Compatible Parts



TE Part # CJ2087-000
[HL2010E-KIT-120V](#)

Customers Also Bought

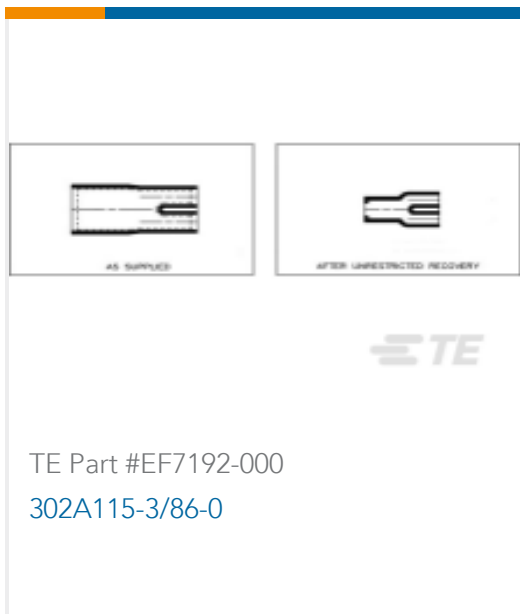
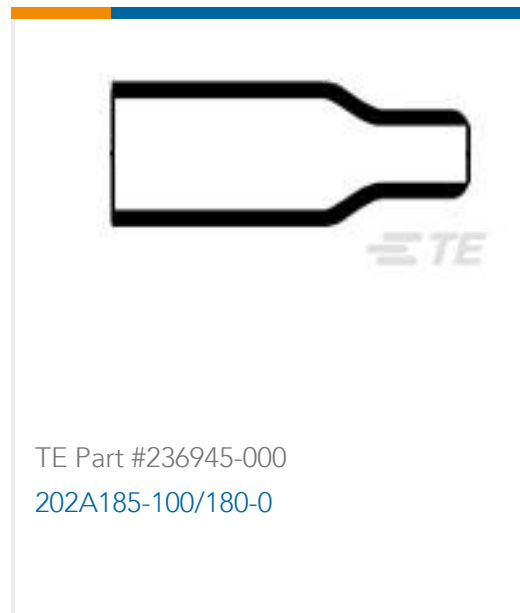
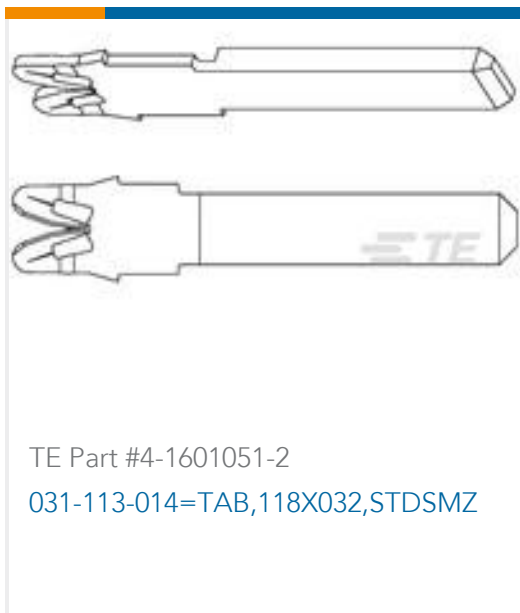

Documents

Datasheets & Catalog Pages

[1654025_Sec4_-3](#)

English

Raychem Molded Parts Visual Guide

English

Product Specifications

[Product Specification](#)

English

X-ON Electronics

Largest Supplier of Electrical and Electronic Components

Click to view similar products for [Heat Shrink Cable Boots & End Caps](#) category:

Click to view products by [TE Connectivity](#) manufacturer:

Other Similar products are found below :

[577159N001](#) [645494-000](#) [CX4132-000](#) [687025-000](#) [705331-000](#) [718446-000](#) [725666N001](#) [729257-000](#) [F27131-000](#) [F85868-000](#) [770-003S106W2](#) [806542N001](#) [807507-000](#) [808059-000](#) [808362-000](#) [808618-000](#) [809125-000](#) [809130-000](#) [809218-000](#) [812014-000](#) [812047-000](#) [813166-000](#) [813767N002](#) [814741-000](#) [819117N001](#) [823026-000](#) [823070-000](#) [825002-000](#) [841189N001](#) [861471-000](#) [866647-000](#) [879515-000](#) [937577-000](#) [957073-000](#) [982033-2](#) [A77813-000](#) [R280576000](#) [D96192-000](#) [163549-000](#) [MTPSRBCL-C](#) [1954015-1](#) [200W531-3-0](#) [202A163-4-0-CS5067](#) [202A343-3-00-0](#) [202B221-13-0](#) [202B231-13-0](#) [202B563-25-07-0](#) [202C241-13-0](#) [202D121-4-01/86-0](#) [202D132-4-07/42-0](#)