

PART NUMBER	REVISION	DESCRIPTION	FEED TYPE
2266956-1	F	FINE CRIMP HEIGHT ADJUST	MECHANICAL
2266956-2	F	FINE CRIMP HEIGHT ADJUST	PNEUMATIC
7-2266956-1	F	MECHANICAL AND CRIMP TOOLING KIT	MECHANICAL
7-2266956-2	F	PNEUMATIC AND CRIMP TOOLING KIT	PNEUMATIC
7-2266956-7	A	CRIMP TOOLING KIT	-

ATLANTIC VERSION TERMINATOR INTERFACE ADAPTER

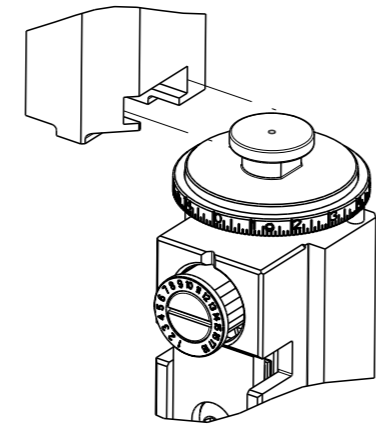

APPLICATOR DATA		
CRIMP	SIZE	TYPE
WIRE	1.40 mm [0.055]	F
INSUL	-	-

APPLICATOR INSTRUCTIONS
408-35042

TERMINAL DATA: ROSENBERGER TERMINAL ROSENBERGER CRIMP SPECIFICATION			
TERMINAL NAME: ROSENBERGER TERMINAL			
WIRE STRIP LENGTH		INSULATION DIAMETER RANGE	
TERMINAL APPLICATION SPECIFICATION	MA-59V059 Rev i00	-	-
TERMINALS APPLIED			
TE TERMINAL	ROSENBERGER TERMINAL	TE TERMINAL	ROSENBERGER TERMINAL
2113073-1	59K13D-1E4/20	2113073-2	59K13D-1E4/20E
2113074-1	59S10L-1E4/20	2113074-2	59S10L-1E4/20E

WIRE SIZE	CRIMP HEIGHT mm [INCH]	CRIMP HEIGHT REFERENCE SETTING
Commscope AMC-58 LL	1.10+/-0.03 [0.043+/-0.001]	10.1

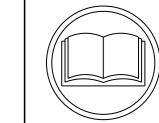

- 1 RECOMMENDED SPARE PARTS
 - 2 REFER TO SUPPLIED INSTRUCTION SHEET FOR CLEANING, LUBRICATION AND STORAGE OF APPLICATOR.
 - 3 CRIMP HEIGHT REFERENCE SETTING WAS THE SETTING USED WHEN THE APPLICATOR WAS QUALIFIED AT THE FACTORY. ADJUSTMENT MAY BE NECESSARY WHEN RUNNING APPLICATOR IN THE FIELD.
 - 4 SEE TERMINAL APPLICATOR SPEC 114-13157 FOR WIRE STRIP LENGTHS.
 - 5 THIS TERMINAL CANNOT BE RUN ON AUTOMATED EQUIPMENT.
 - 6 TERMINAL LUBRICANT IS RECOMMENDED.
7. UNLESS SPECIFIED OTHERWISE TORQUE VALUES SHALL BE USED PER DOCUMENT, 101-35000.

***WARNING**
ON INSTALLATION, SET WIRE DISC TO CRIMP HEIGHT REFERENCE SETTING FOR LARGEST WIRE SIZE. CRIMP HEIGHT REFERENCE SETTINGS GREATER THAN THE VALUE SHOWN MAY CAUSE DAMAGE TO THE CRIMP TOOLING. REFER TO THE INSTRUCTION SHEET FOR PROPER SETUP AND ADJUSTMENTS.

LOC	DIST	REVISIONS			
A	66	REV	DATE	BY	APPV
		C	21 JUN 2016	MEH	GB
		D	06 JUL 2016	MEH	TE
		E	18 MAY 2018	YY	JDG
		F	11 JUN 2018	AW	GB

-	1	1	1	1	455888-1	SPACER, CRIMPER	261
-	1	-	1	-	2119640-1	PUSH ROD, AIR FEED	250
-	1	-	1	-	1803259-1	BUSHING, FLANGED	249
-	1	-	1	-	2119641-1	FEED CAM, AIR FEED	248
-	-	1	-	1	2119580-1	MECHANICAL FEED ASSEMBLY	239
-	1	-	1	-	2063440-1	AIR FEED MODULE	238
-	2	-	2	-	21045-3	RING, RETAIN, EXTERN, 3/16 CRESCENT	172
-	REF	REF	REF	REF	994970-2	COUNTER, MAGNETIC	164
-	1	-	1	-	240638-1	SPRING, FEED FINGER	163
-	1	-	1	-	3-23627-7	PIN, RETAIN, GRVD, 3/16 X .854	137
-	1	-	1	-	2119799-1	HOLDER, FEED FINGER, AF	136
-	1	1	1	1	2119955-1	ASSY, LUBRICATOR, SIDE FEED	113
-	1	1	1	1	2844908-1	SCREW, LOCKING	99
-	1	1	1	1	2844907-1	POST, LOCKING	98
-	1	1	1	1	455888-5	SPACER, CRIMPER	82
-	1	1	1	1	1803607-1	DOCUMENTATION PACKAGE	71
-	1	1	1	1	2119740-1	TAG, IDENTIFICATION	67
-	2	2	2	2	2168078-1	SCREW, DRIVE, RH, RoHS, 2 x .188	66
-	1	1	1	1	2168083-2	SCR, SKT HD CAP, RoHS, M4 X 8.0	60
-	1	1	1	1	5-18022-5	SCR, HEX HD CAP, M4 X 6.0	59
-	1	1	1	1	1338685-1	PAWL, FEED	56
-	4	4	4	4	2168083-3	SCR, SKT HD CAP, RoHS, M4 X 12.0	54
-	2	2	2	2	1-2168083-0	SCR, SKT HD CAP, RoHS, M4 X 10	53
-	1	1	1	1	5018030-1	NUT, HEX, REG, RoHS, M3	52
-	1	1	1	1	811242-5	BUMPER, HOLD DOWN	51
-	1	1	1	1	690753-2	SPACER, TONKER	50
-	1	2	1	2	18023-9	SCR, SKT HD CAP M4 X 6.0	49
-	-	1	-	1	2119652-1	FEED CAM, PRE FEED	48
-	-	1	-	1	2119653-1	FEED CAM, POST FEED	47
-	1	1	1	1	1803583-9	APPLICATOR BASIC ASSEMBLY, SF	46
-	1	1	1	1	1803515-1	RAM ASSEMBLY, SF ATLANTIC	44
-	1	1	1	1	1803602-1	SCR, BHSC, RoHS (M8 X 25)	41
-	1	1	1	1	2-1752356-3	SUPPORT, TERMINAL	34
-	2	2	2	2	2079383-5	SCR, BHSC, RoHS (M4 X 20)	33
-	2	2	2	2	2-2844962-3	SPACER, CYLINDRICAL, STRIP GUIDE	30
-	1	1	1	1	2844992-1	ASSEMBLY, STRIP GUIDE	29
-	1	1	1	1	455888-3	SPACER, CRIMPER	28
-	1	1	1	1	1320928-2	STRIP GUIDE	24
-	1	1	1	1	1-18028-2	WASHER, FLAT, REG M4	20
-	1	1	1	1	3-22280-3	SPRING, COMPRESSION	12
-	1	1	1	1	356885-5	STOP, SHEAR	11
-	1	1	1	1	1803216-1	HOLDER, SHEAR	10
-	1	1	1	1	1-1338293-2	SHEAR, FLOATING	9
-	1	2	2	1	1803190-4	ANVIL, WIRE	8
-	-	-	-	-	-	-	7
-	-	-	-	-	-	-	6
-	1	1	1	1	1803419-3	DEPRESSOR, SHEAR	5
-	-	-	-	-	-	-	4
-	-	-	-	-	-	-	3
-	-	-	-	-	-	-	2
-	1	2	2	1	1-1633609-5	CRIMPER, WIRE	1

ATLANTIC VERSION
Shown on sheets 1 of 4 & 2 of 4
(Pacific version shown on sheets 3 of 4 & 4 of 4)

DIMENSIONS:		TOLERANCES UNLESS OTHERWISE SPECIFIED:		APPLICATOR DATA	
mm	0 PLC ±	1 PLC ±	2 PLC ±	3 PLC ±	4 PLC ±
	ANGLES	FINISH	-		
MATERIAL		WEIGHT	-		

OWN	J. HOU	20AUG2015	TE Connectivity Harrisburg, PA 17105-3608
CHK	L. ZHANG	20AUG2015	
APVD	J. GUO	20AUG2015	
NAME	Ocean Side Feed Applicator		
SIZE	CAGE CODE	DRAWING NO	RESTRICTED TO
A1	00779	2266956	-
Customer Accessible Production Drawing			SCALE 1:2 SHEET 1 OF 4 REV F

LOC	DIST	REVISIONS				
A	66	REV	DESCRIPTION	DATE	OWN	APVD
-	-	1	SEE SHEET 1	-	-	-

FEED TYPE MECHANICAL

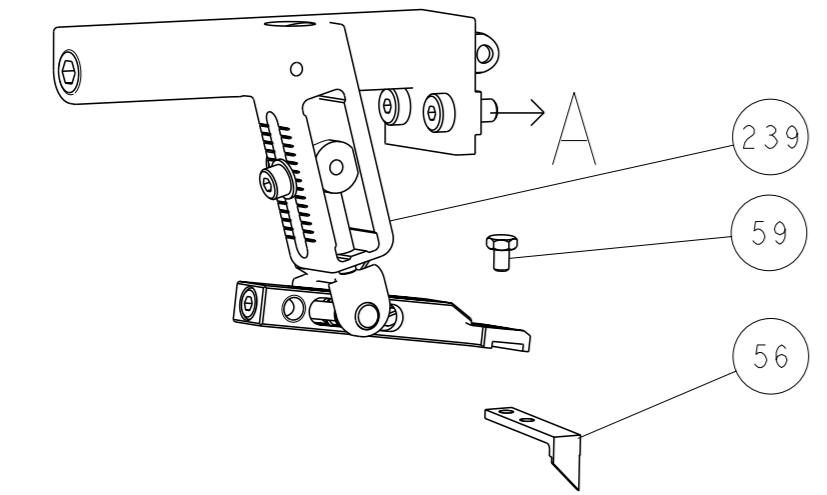

PNEUMATIC

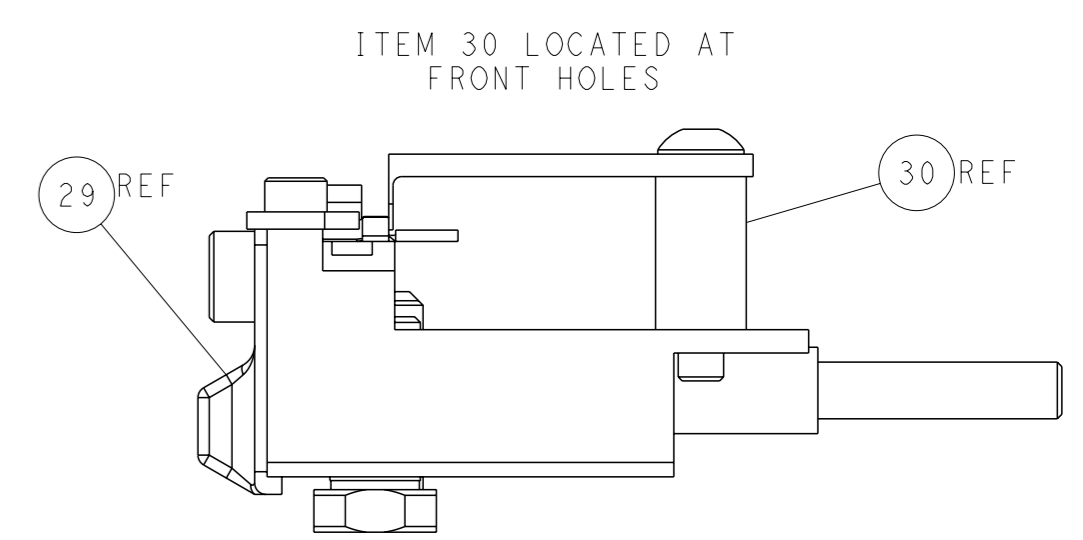
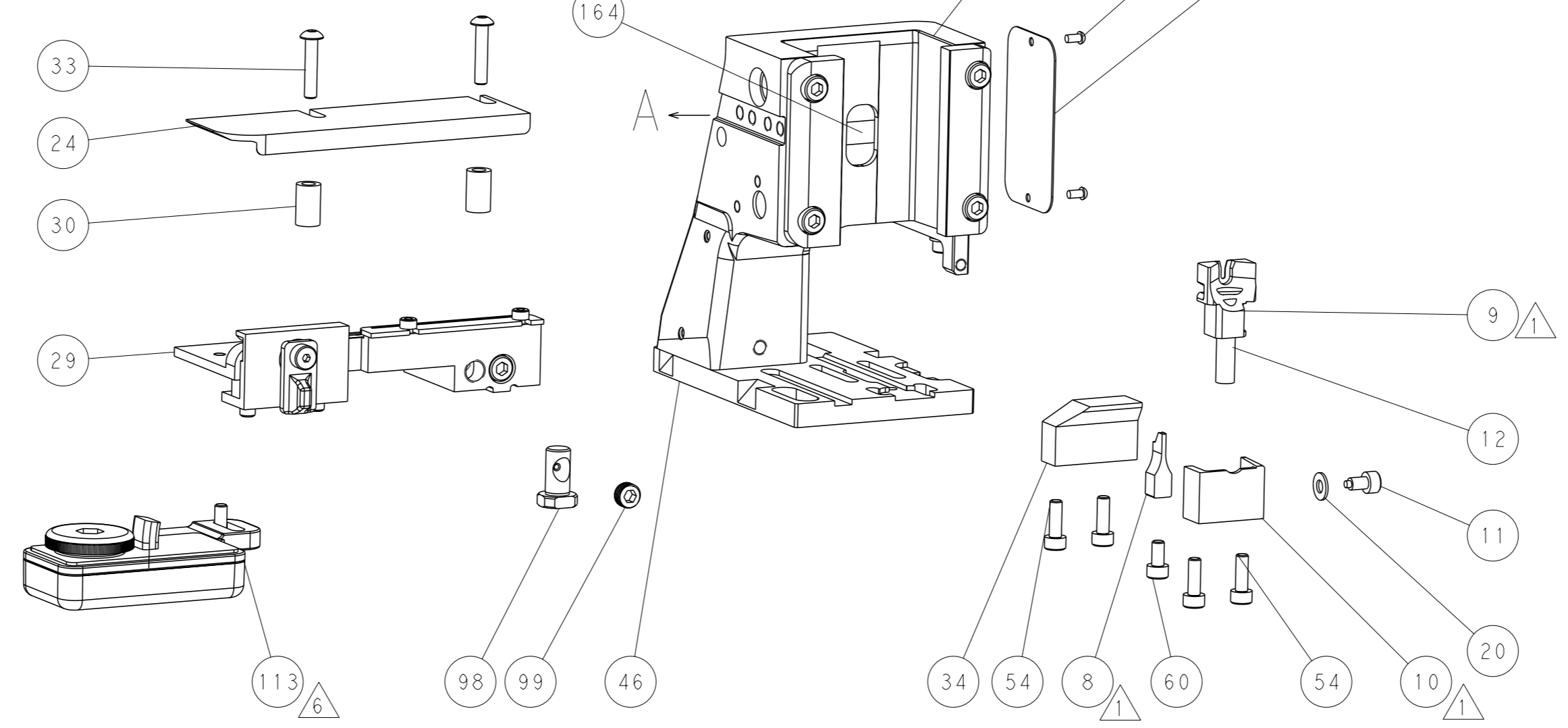
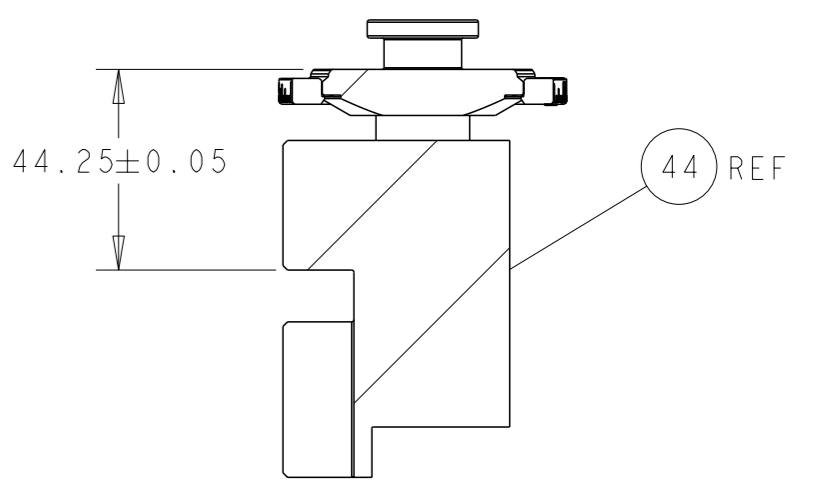
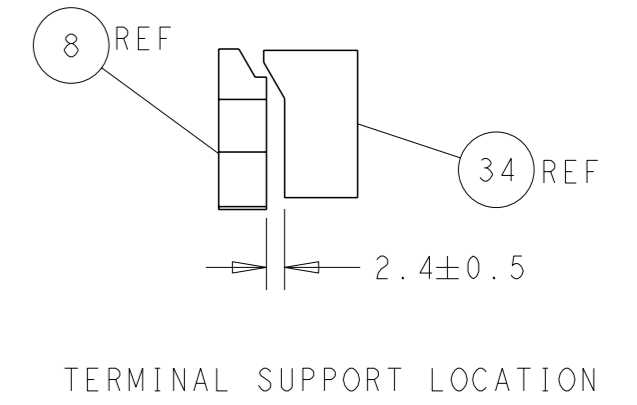
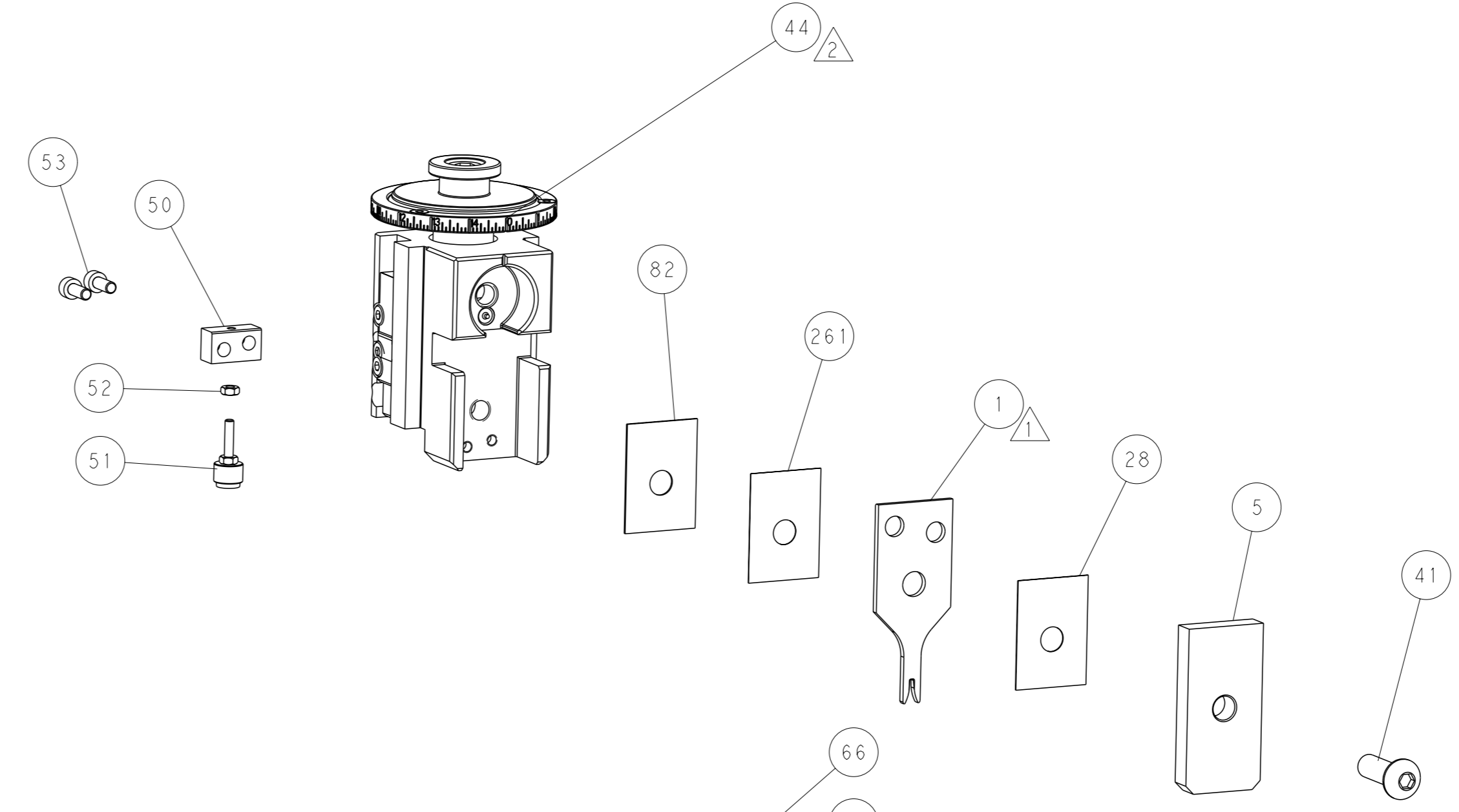
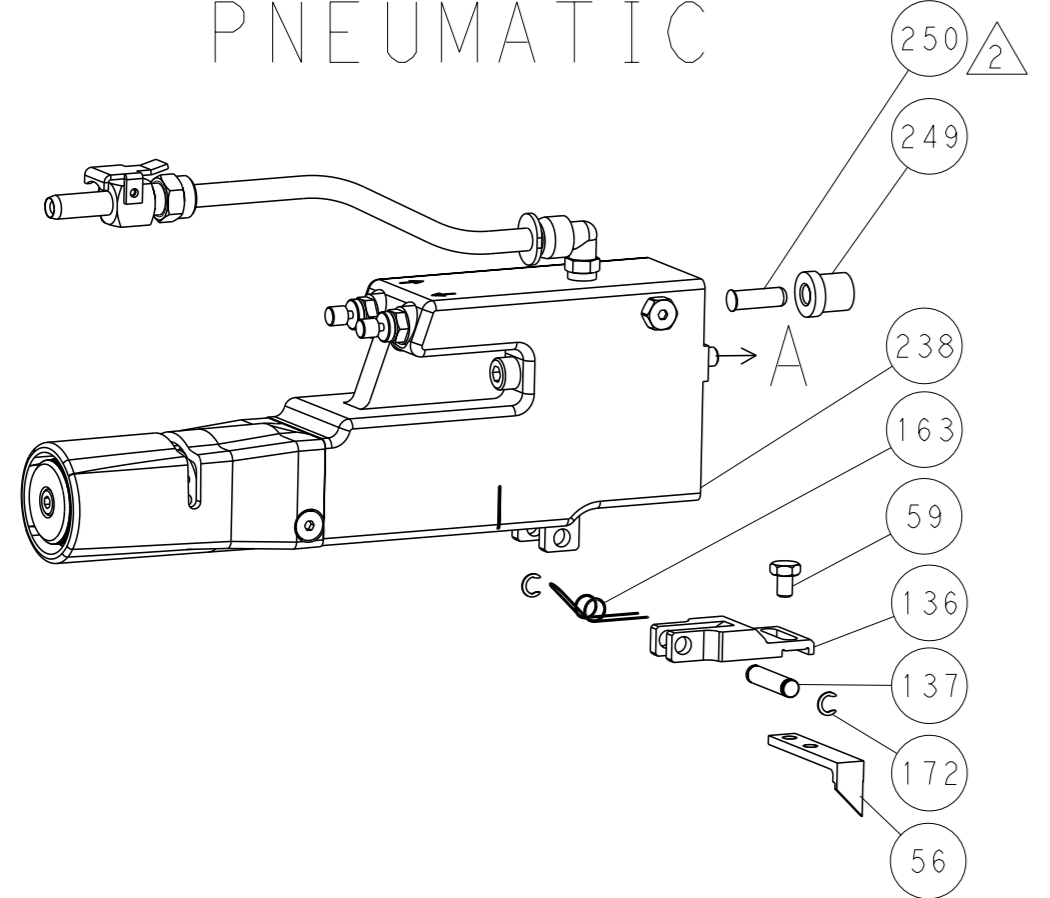

CAM POSITIONS

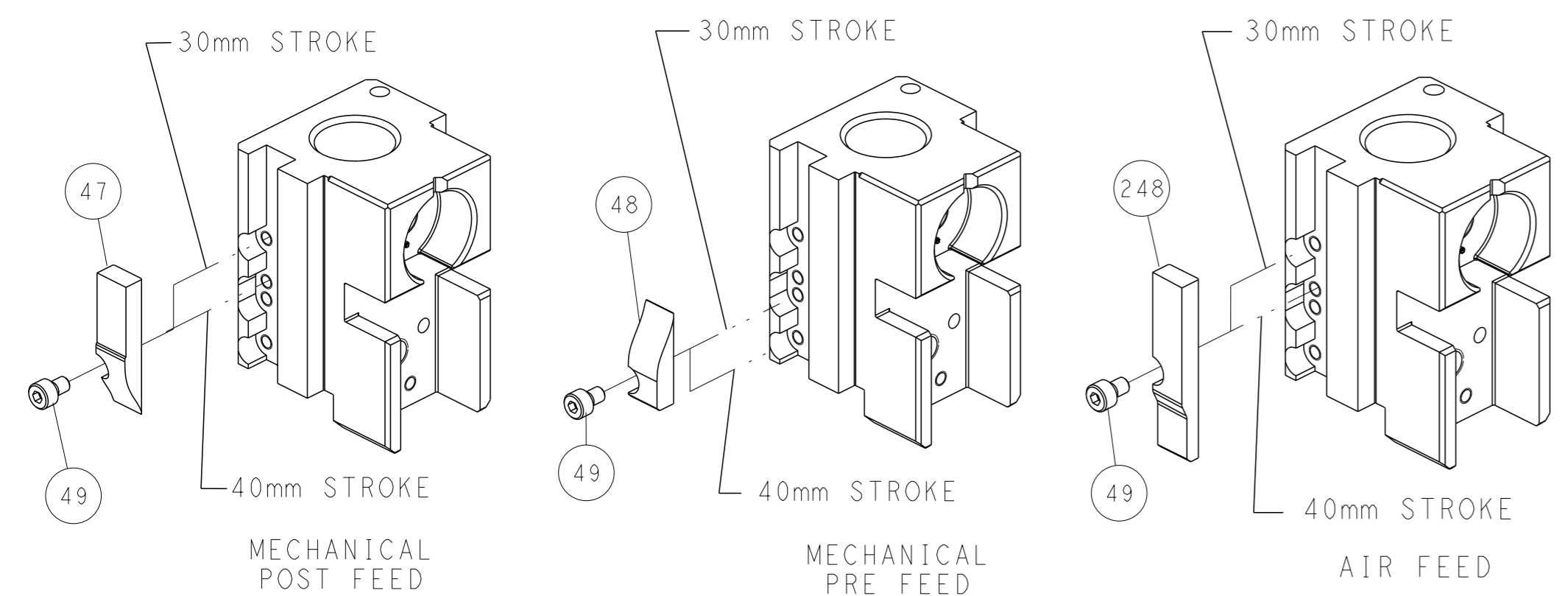

ATLANTIC VERSION
 Shown on sheets 1 of 4 & 2 of 4
 (Pacific version shown on sheets 3 of 4 & 4 of 4)

<small>THIS DRAWING IS A CONTROLLED DOCUMENT FOR TYCO ELECTRONICS CORPORATION. IT IS SUBJECT TO CHANGE AND THE CONTROL AND RESTRICTION DESIGNATION SHOULD BE CONTACTED FOR THE LATEST REVISION.</small>		OWN: J. HOU 20AUG2015 CHK: L. ZHANG 20AUG2015 APVD: H. GUO 20AUG2015	NAME: Ocean Side Feed Applicator SIZE: A1 CAGE CODE: 00779 DRAWING NO: 2266956	TE Connectivity Harrisburg, PA 17105-3608
DIMENSIONS: mm TOLERANCES UNLESS OTHERWISE SPECIFIED: 0 PLC ± 1 PLC ± 2 PLC ± 3 PLC ± 4 PLC ± ANGLES FINISH ±	WEIGHT: - SCALE: 1:2 SHEET: 2 of 4 REV: F	RESTRICTED TO: - Customer Accessible Production Drawing		

PART NUMBER	REVISION	DESCRIPTION	FEED TYPE
2-2266956-1	F	FINE CRIMP HEIGHT ADJUST	MECHANICAL
2-2266956-2	F	FINE CRIMP HEIGHT ADJUST	PNEUMATIC
7-2266956-7	A	CRIMP TOOLING KIT	-

PACIFIC VERSION TERMINATOR
INTERFACE ADAPTER

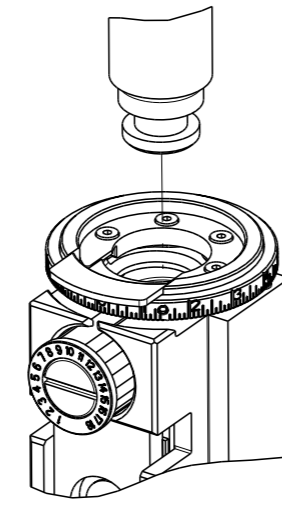

APPLICATOR DATA		
CRIMP	SIZE	TYPE
WIRE	1.40 mm [.055]	F
INSUL	-	-

APPLICATOR INSTRUCTIONS
408-35042

TERMINAL DATA: ROSENBERGER TERMINAL ROSENBERGER CRIMP SPECIFICATION			
TERMINAL NAME: ROSENBERGER TERMINAL			
WIRE STRIP LENGTH		INSULATION DIAMETER RANGE	
TERMINAL APPLICATION SPECIFICATION	MA-59V059 Rev 100	-	-
TERMINALS APPLIED			
TE TERMINAL	ROSENBERGER TERMINAL	TE TERMINAL	ROSENBERGER TERMINAL
2113073-1	59K13D-1E4/20	2113073-2	59K13D-1E4/20E
2113074-1	59S10L-1E4/20	2113074-2	59S10L-1E4/20E

WIRE SIZE	CRIMP HEIGHT mm [INCH]	CRIMP HEIGHT REFERENCE SETTING
Commscope AMC-58 LL	1.10 +/- 0.03 [.043 +/- .001]	10.1



- 1 RECOMMENDED SPARE PARTS
 - 2 REFER TO SUPPLIED INSTRUCTION SHEET FOR CLEANING, LUBRICATION AND STORAGE OF APPLICATOR.
 - 3 CRIMP HEIGHT REFERENCE SETTING WAS THE SETTING USED WHEN THE APPLICATOR WAS QUALIFIED AT THE FACTORY. ADJUSTMENT MAY BE NECESSARY WHEN RUNNING APPLICATOR IN THE FIELD.
 - 4 SEE TERMINAL APPLICATOR SPEC 114-13157 FOR WIRE STRIP LENGTHS.
 - 5 THIS TERMINAL CANNOT BE RUN ON AUTOMATED EQUIPMENT.
 - 6 TERMINAL LUBRICANT IS RECOMMENDED.
7. UNLESS SPECIFIED OTHERWISE TORQUE VALUES SHALL BE USED PER DOCUMENT, 101-35000.

***WARNING**
ON INSTALLATION, SET WIRE DISC TO CRIMP HEIGHT REFERENCE SETTING FOR LARGEST WIRE SIZE. CRIMP HEIGHT REFERENCE SETTINGS GREATER THAN THE VALUE SHOWN MAY CAUSE DAMAGE TO THE CRIMP TOOLING, REFER TO THE INSTRUCTION SHEET FOR PROPER SETUP AND ADJUSTMENTS.

LOC	DIST	REVISIONS					
A	66	P	LYR	DESCRIPTION	DATE	OWN	APVD
-	-	-	-	SEE SHEET 1	-	-	-

-	1	1	455888-1	SPACER, CRIMPER	26.1
-	1	-	2119640-1	PUSH ROD, AIR FEED	250
-	1	-	1803259-1	BUSHING, FLANGED	249
-	-	1	2119580-1	MECHANICAL FEED ASSEMBLY	239
-	1	-	2063440-1	AIR FEED MODULE	238
-	2	-	21045-3	RING, RETAIN, EXTERN, 3/16 CRESCENT	172
-	REF	REF	994970-2	COUNTER, MAGNETIC	164
-	1	-	240638-1	SPRING, FEED FINGER	163
-	1	-	2119641-2	FEED CAM, AIR FEED	151
-	4	4	2168083-9	SCR, SKT HD CAP, RoHS, M4 X 20	143
-	-	1	2119653-2	FEED CAM, POST FEED	142
-	1	1	1-1803583-0	APPLICATOR BASIC ASSEMBLY, SF	141
-	1	1	1803516-1	RAM ASSEMBLY, SF PACIFIC	140
-	1	-	3-23627-7	PIN, RETAIN, GRVD, 3/16 X .854	137
-	1	-	2119799-1	HOLDER, FEED FINGER, AF	136
-	1	1	2119955-1	ASSY, LUBRICATOR, SIDE FEED	113
-	1	1	2844908-1	SCREW, LOCKING	99
-	1	1	2844907-1	POST, LOCKING	98
-	1	1	455888-5	SPACER, CRIMPER	82
-	1	1	1803607-1	DOCUMENTATION PACKAGE	71
-	1	1	2119740-1	TAG, IDENTIFICATION	67
-	2	2	2168078-1	SCREW, DRIVE, RH, RoHS, 2 x .188	66
-	1	1	5-18022-5	SCR, HEX HD CAP, M4 X 6.0	59
-	1	1	1338685-1	PAWL, FEED	56
-	2	2	1-2168083-0	SCR, SKT HD CAP, RoHS, M4 X 10	53
-	1	1	5018030-1	NUT, HEX, REG, RoHS, M3	52
-	1	1	811242-5	BUMPER, HOLD DOWN	51
-	1	1	690753-2	SPACER, TONKER	50
-	1	2	18023-9	SCR, SKT HD CAP M4 X 6.0	49
-	-	1	2119652-1	FEED CAM, PRE FEED	48
-	1	1	1803602-1	SCR, BHSC, RoHS (M8 X 25)	41
-	1	1	2-1752356-3	SUPPORT, TERMINAL	34
-	2	2	2079383-5	SCR, BHSC, RoHS (M4 X 20)	33
-	2	2	2-2844962-3	SPACER, CYLINDRICAL, STRIP GUIDE	30
-	1	1	2844992-1	ASSEMBLY, STRIP GUIDE	29
-	1	1	455888-3	SPACER, CRIMPER	28
-	1	1	1320928-2	STRIP GUIDE	24
-	1	1	1-18028-2	WASHER, FLAT, REG M4	20
-	1	1	3-22280-3	SPRING, COMPRESSION	12
-	1	1	356885-5	STOP, SHEAR	11
-	1	1	1803216-1	HOLDER, SHEAR	10
-	1	1	1-1338293-2	SHEAR, FLOATING	9
-	1	1	1803190-4	ANVIL, WIRE	8
-	-	-	-	-	7
-	-	-	-	-	6
-	1	1	1803419-3	DEPRESSOR, SHEAR	5
-	-	-	-	-	4
-	-	-	-	-	3
-	-	-	-	-	2
-	1	1	1-1633609-5	CRIMPER, WIRE	1

PACIFIC VERSION
Shown on sheets 3 of 4 & 4 of 4
(Atlantic version shown on sheets 1 of 4 & 2 of 4)

<small>THE DRAWING IS UNPUBLISHED. IT IS SUBJECT TO CHANGE AND THE USER ASSUMES ALL RESPONSIBILITY FOR OBTAINING THE LATEST REVISION. SHOULD BE CONTACTED FOR THE LATEST REVISION.</small>		OWN J. HOU 20AUG2015 CHK L. ZHANG 20AUG2015 APVD U. GUO 20AUG2015	NAME STE TE Connectivity Harrisburg, PA 17105-3608
DIMENSIONS: mm 	TOLERANCES UNLESS OTHERWISE SPECIFIED: 0 PLC ± 1 PLC ± 2 PLC ± 3 PLC ± 4 PLC ± ANGLES FINISH ±	PRODUCT SPEC APPLICATION SPEC WEIGHT SCALE 1:2 SHEET 3 OF 4 REV F	SIZE CAGE CODE DRAWING NO A1 00779 C=2266956
MATERIAL FINISH		Customer Accessible Production Drawing	

LOC	DIST	REVISIONS			
A	66	REV	DATE	OWN	APVD
		-	SEE SHEET 1	-	-

FEED TYPE MECHANICAL

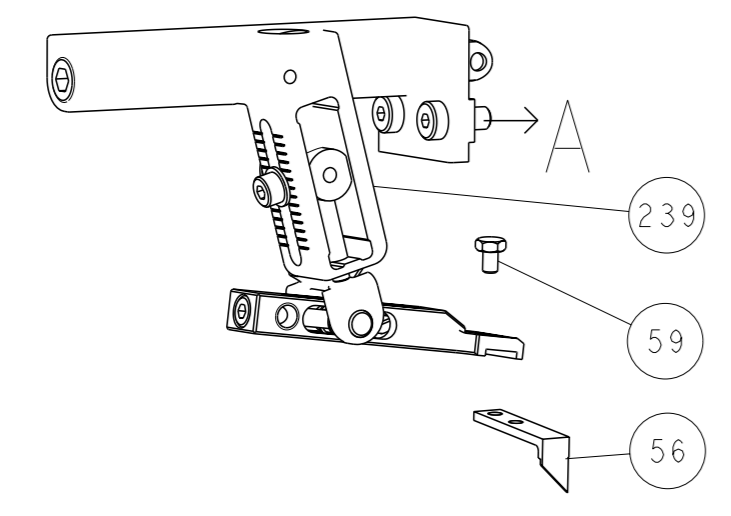

PNEUMATIC

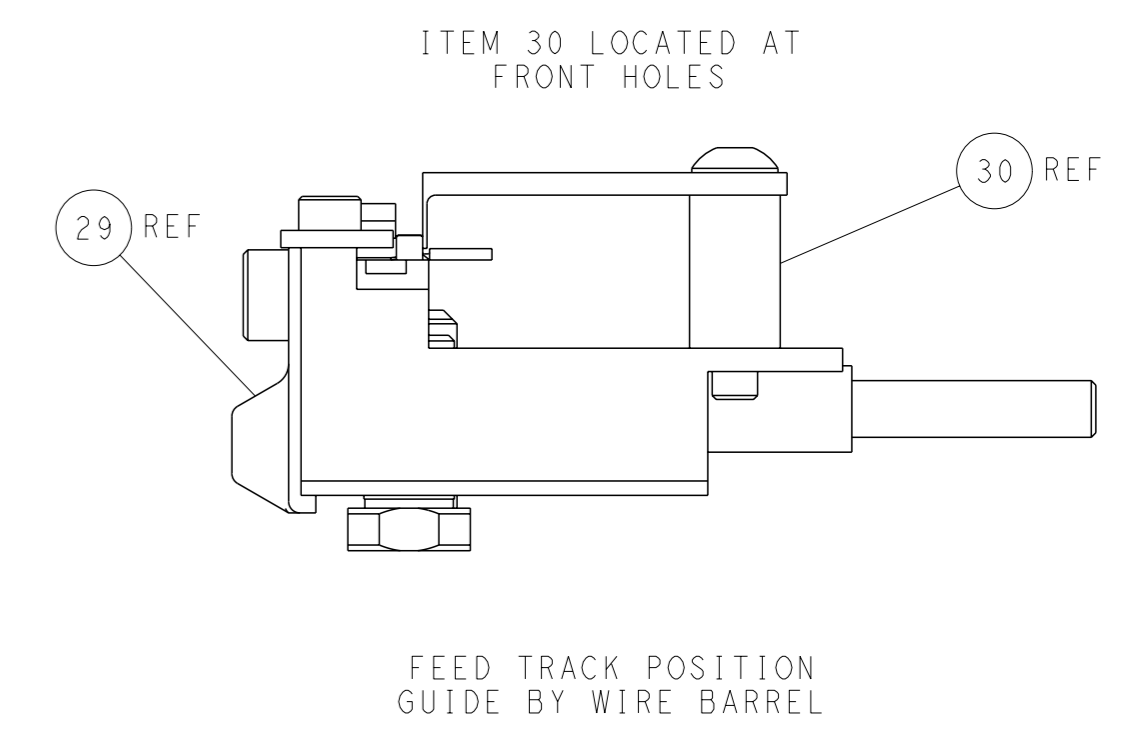
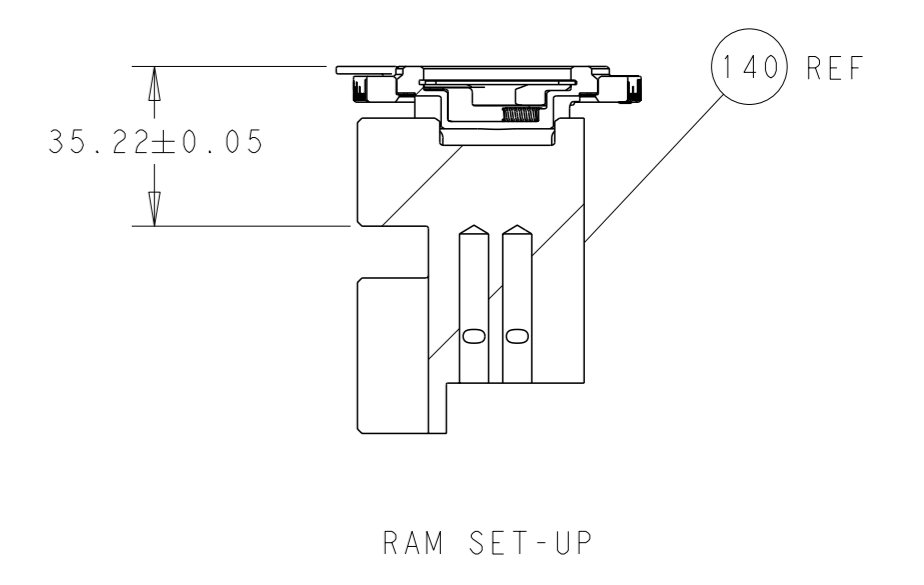
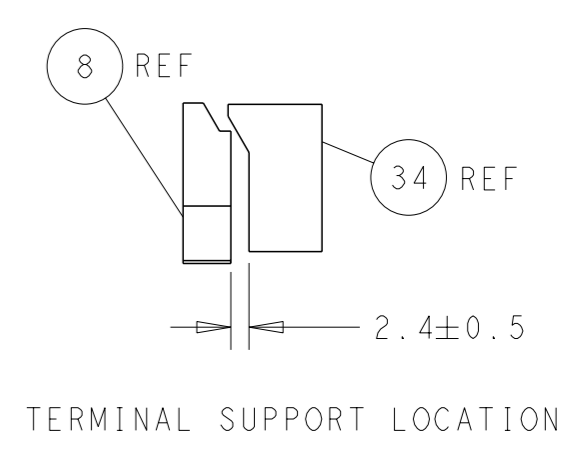
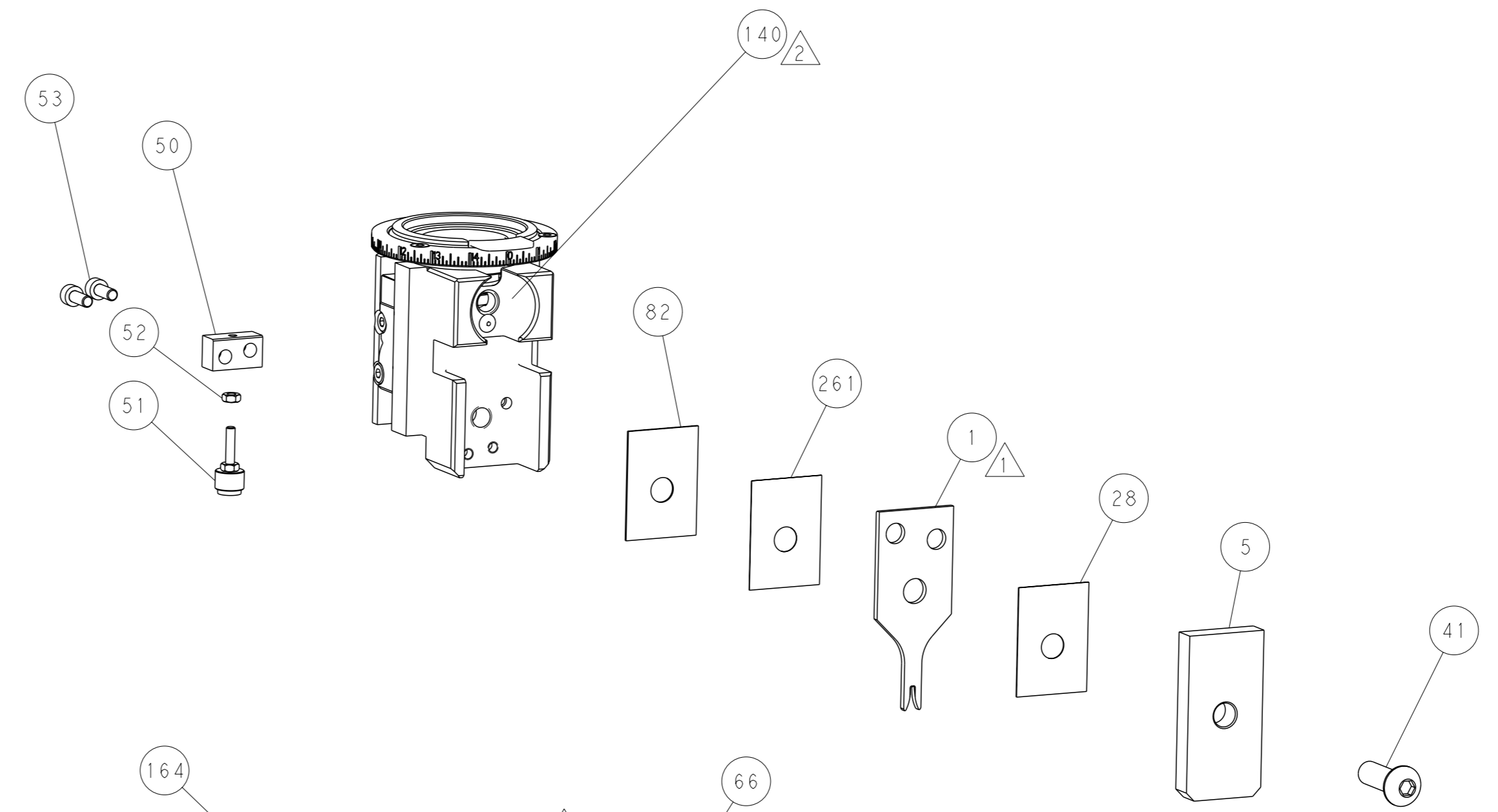
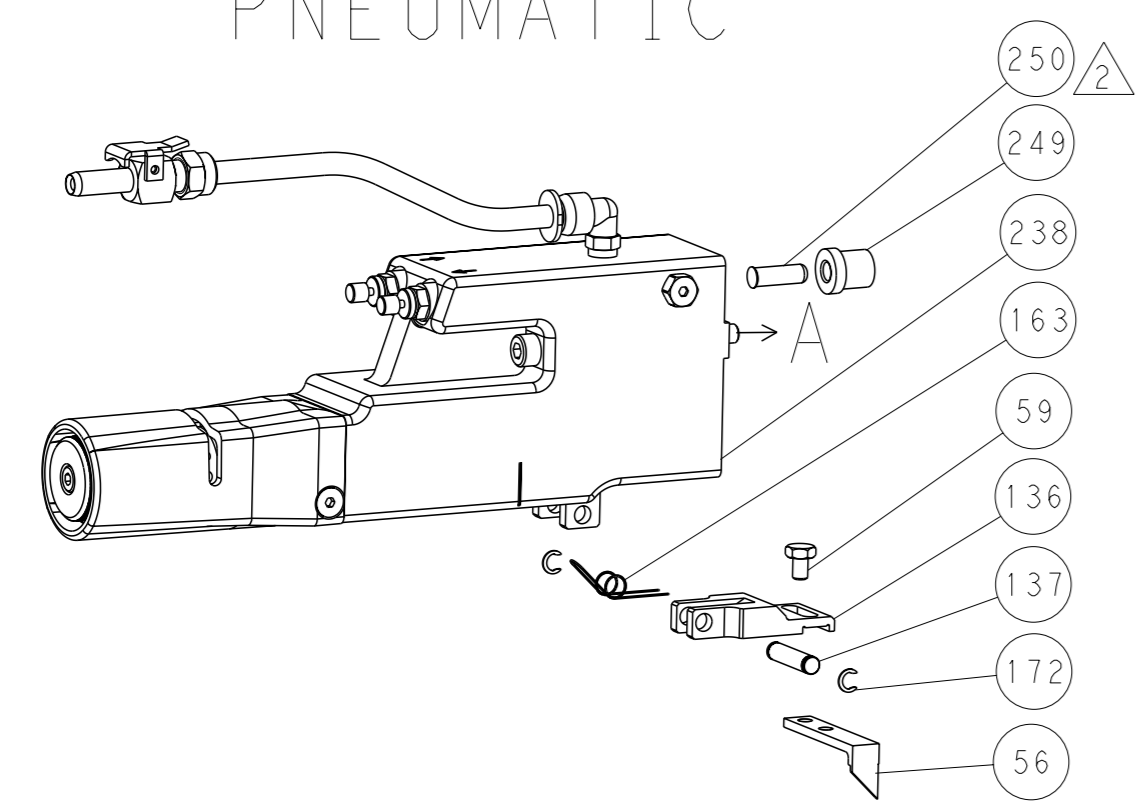

CAM POSITIONS

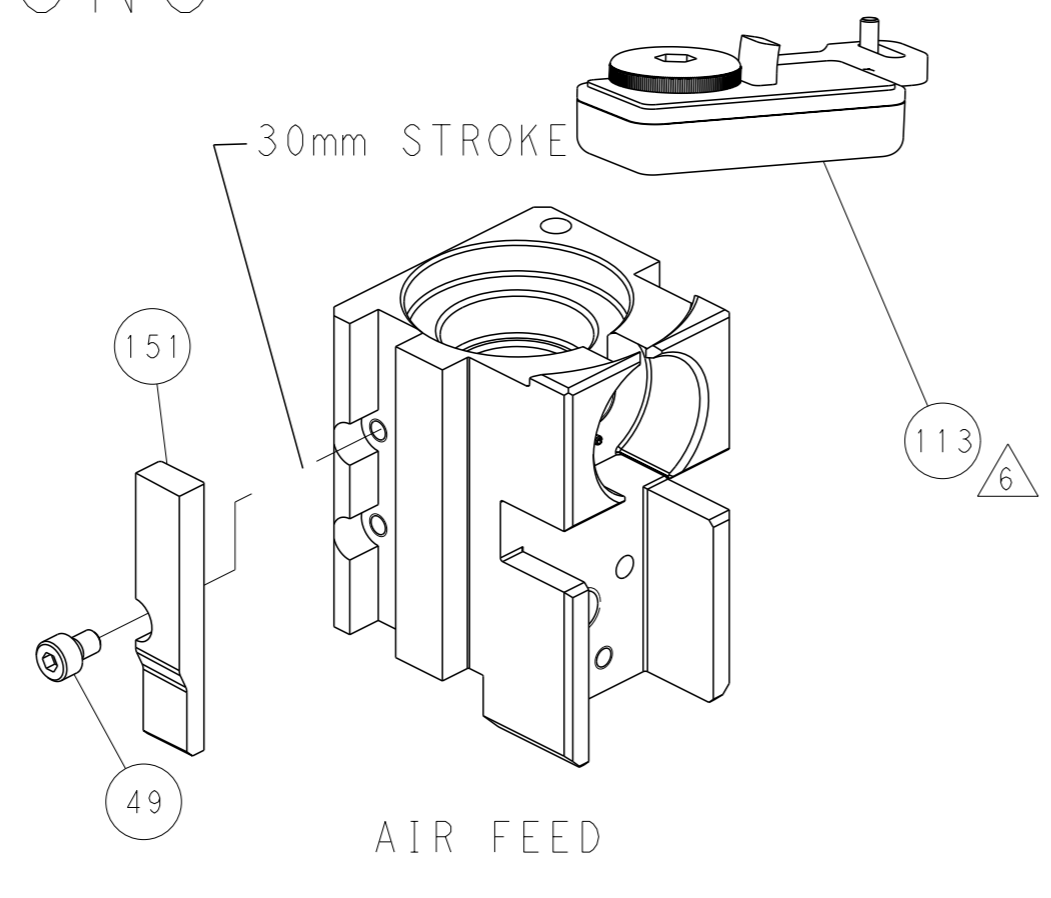
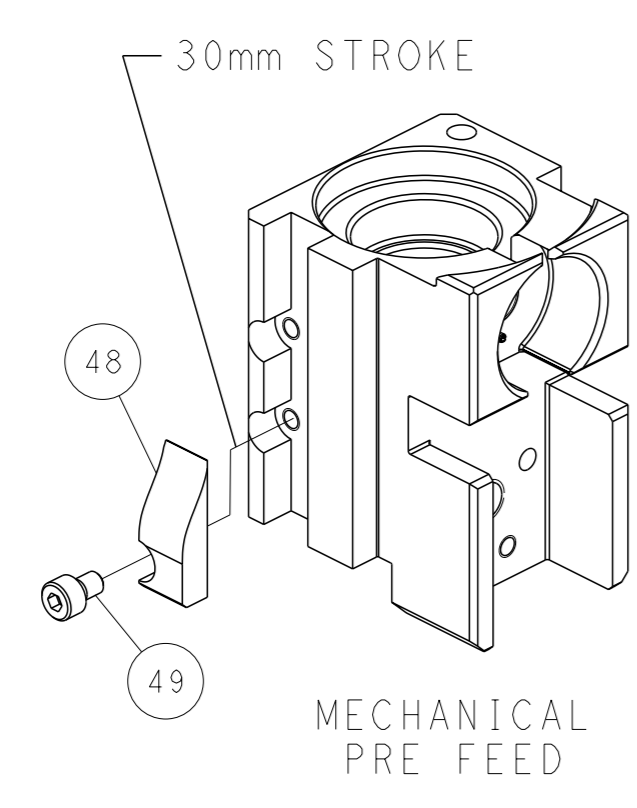
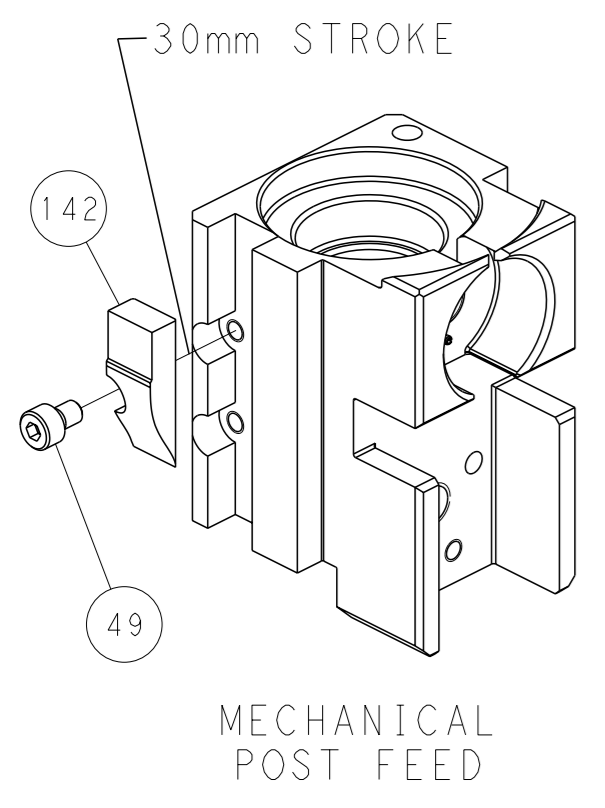

PACIFIC VERSION
 Shown on sheets 3 of 4 & 4 of 4
 (Atlantic version shown on sheets 1 of 4 & 2 of 4)

<small>THIS DRAWING IS A CONTROLLED DOCUMENT FOR TYCO ELECTRONICS CORPORATION. IT IS SUBJECT TO CHANGE AND THE CONTROLLING ORGANIZATION SHOULD BE CONTACTED FOR THE LATEST REVISION.</small>		OWN: J. HOU CHK: L. ZHANG APVD: H. GUO	DATE: 20AUG2015 DATE: 20AUG2015 DATE: 20AUG2015	TE Connectivity Harrisburg, PA 17105-3608
DIMENSIONS: mm TOLERANCES UNLESS OTHERWISE SPECIFIED: 0 PLC ± 1 PLC ± 2 PLC ± 3 PLC ± 4 PLC ± ANGLES FINISH ±		NAME: Ocean Side Feed Applicator SIZE: A1 CAGE CODE: 00779 DRAWING NO: C=2266956	RESTRICTED TO: F SCALE: 1:2 SHEET: 4 of 4 REV: F	

X-ON Electronics

Largest Supplier of Electrical and Electronic Components

Click to view similar products for [Bench Top Tools](#) category:

Click to view products by [TE Connectivity](#) manufacturer:

Other Similar products are found below :

[6-1372442-6](#) [63801-4462](#) [63801-4561](#) [63801-7269](#) [679527-1](#) [691667-1](#) [7-21000-9](#) [768539-1](#) [854130-1](#) [854946-2](#) [856203-1](#) [904449-1](#) [9-22280-9](#) [986096-2](#) [992438-3](#) [1-21000-3](#) [1-21000-1](#) [1-25022-4](#) [1302263353](#) [1302263355](#) [1302261057](#) [1302261101](#) [1302261206](#) [1302261560](#) [1302263123](#) [1302264036](#) [1424264-1](#) [1424267-1](#) [1428211-1](#) [1428287-1](#) [1-455755-6](#) [1752744-1](#) [18023-9](#) [189763-1](#) [1901726-1](#) [2079747-1](#) [21001-2](#) [2119083-1](#) [2119085-1](#) [2119371-1](#) [2161930-1](#) [2217088-2](#) [2217339-1](#) [2217347-1](#) [22281-9](#) [22374-7](#) [284565-000](#) [F1 Handle Spring](#) [19228-0213](#) [2030790-2](#)