

LOC	DIST	REVISIONS			
P	LTN	DESCRIPTION	DATE	DMN	APVD
GP	00	A	INITIAL RELEASE	28SEP2016	LL SH

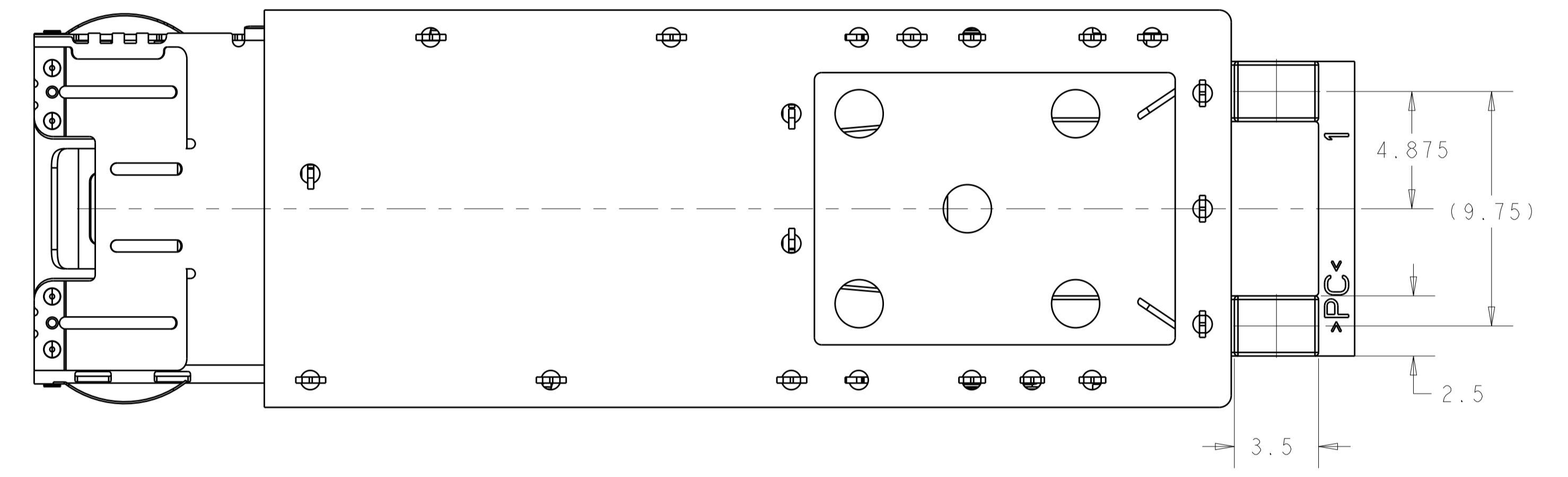

- 1 MATERIAL:  
 CAGE ASSEMBLY - 0.25mm THICK NICKEL SILVER ALLOY.  
 EMI SPRINGS - COPPER ALLOY.  
 PCB GASKET - RF ABSORBER.  
 LIGHT PIPE - POLYCARBONATE, CLEAR.  
 LIGHT PIPE BRACKET - STAINLESS STEEL.
- 2 FINISH  
 EMI SPRINGS - 0.8um MIN NICKEL, NON-PLATED EDGES PERMISSIBLE.
- 3. MATES WITH SFP MSA COMPLIANT TRANSCEIVERS.
- 4 PADS AND VIAS CHASSIS GROUND.
- 5 DATUM AND BASIC DIMENSION ESTABLISHED BY CUSTOMER.
- 6 REFERENCE APPLICATION SPEC. 114-13120, HOLE A, FOR RECOMMENDED DRILL HOLE DIAMETER AND PLATING THICKNESS.
- 7 REFERENCE APPLICATION SPEC. 114-13120, HOLE B, FOR RECOMMENDED DRILL HOLE DIAMETER AND PLATING THICKNESS.
- 8 REFERENCE APPLICATION SPEC. 114-13120, HOLE C, FOR RECOMMENDED DRILL HOLE DIAMETER AND PLATING THICKNESS.
- 9. MINIMUM PC BOARD THICKNESS:  
 SINGLE SIDED = 1.50mm
- 10 LIGHT PIPE ASSEMBLY SHIPPED UNASSEMBLED TO CAGE ASSEMBLY. CAGE ASSEMBLY TO BE PRESSED INTO PCB PRIOR TO ATTACHING THE LIGHT PIPE ASSEMBLY TO THE CAGE.
- 11 LIGHT PIPE AND LIGHT PIPE BRACKET SHIPPED ASSEMBLED.
- 12. CONTACT STANDOFF WILL PIERCE GASKET WHEN PROPERLY PRESSED INTO PCB.

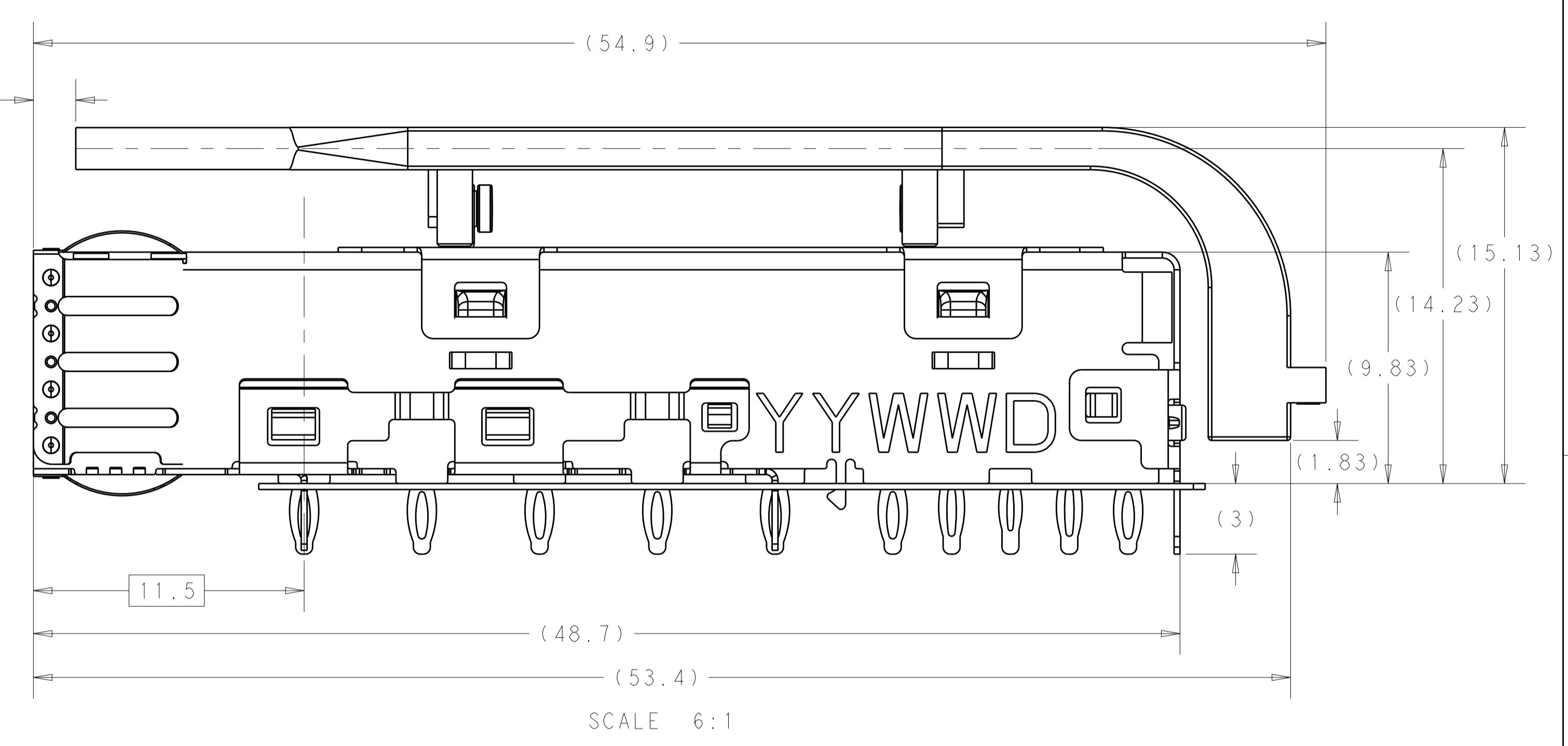
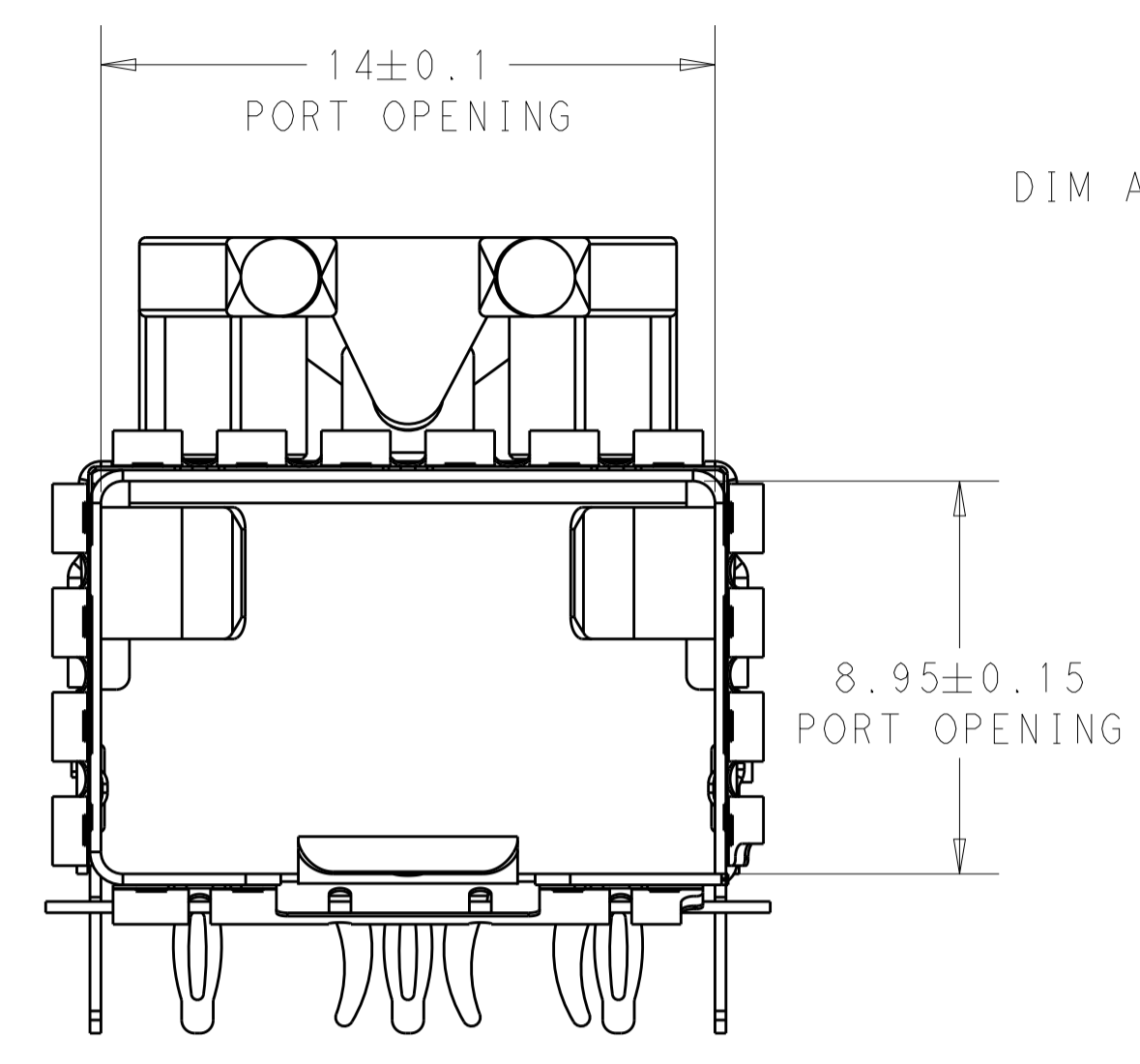
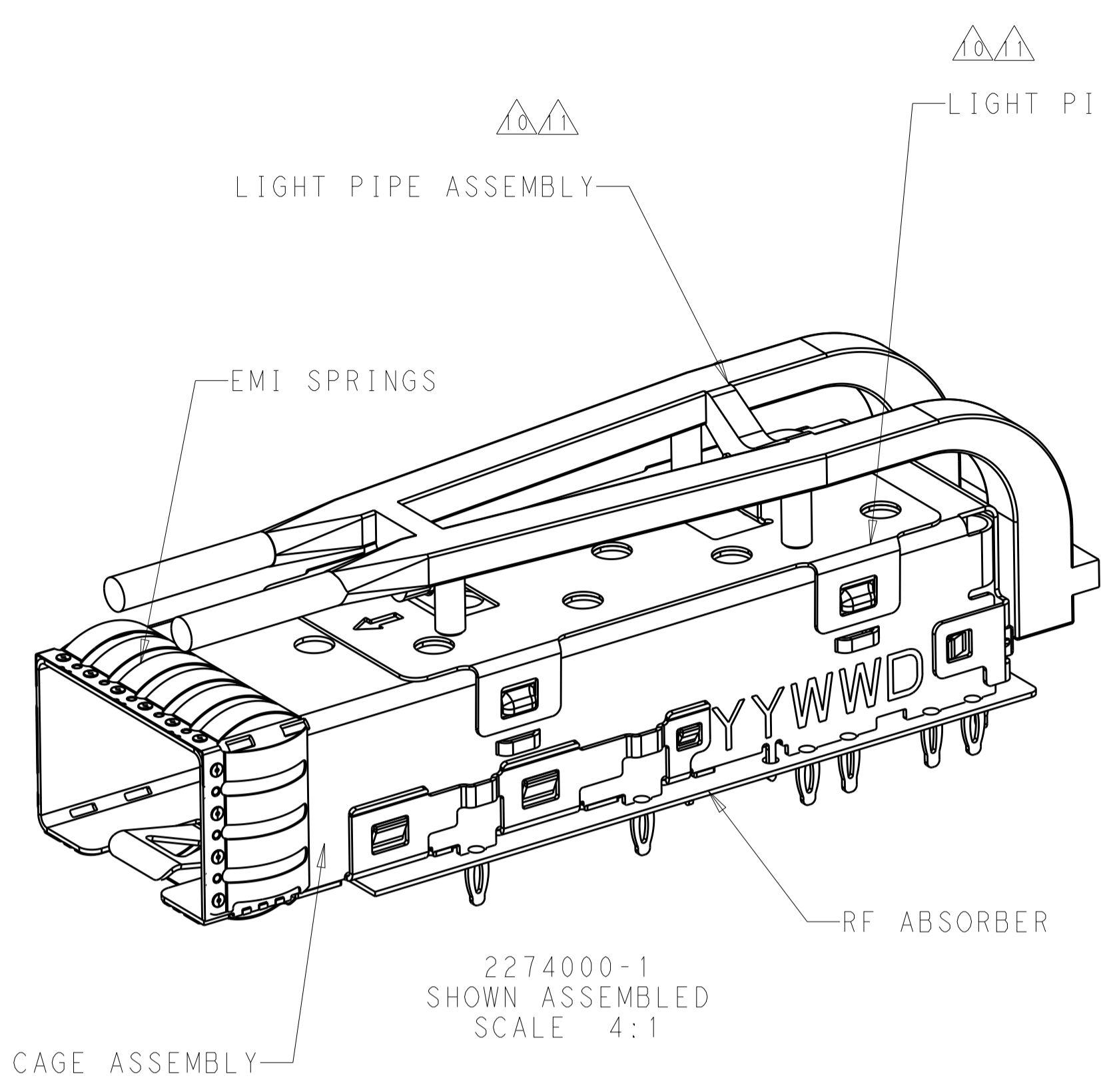
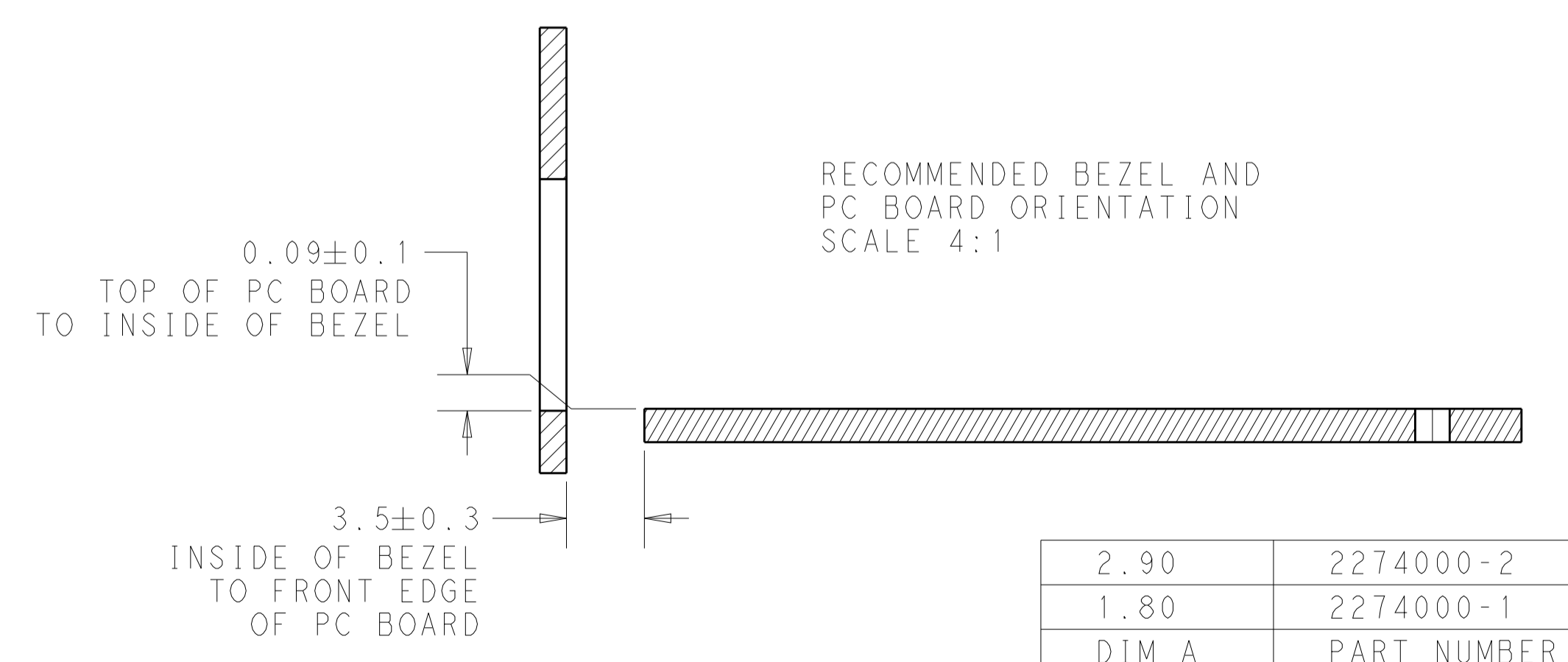
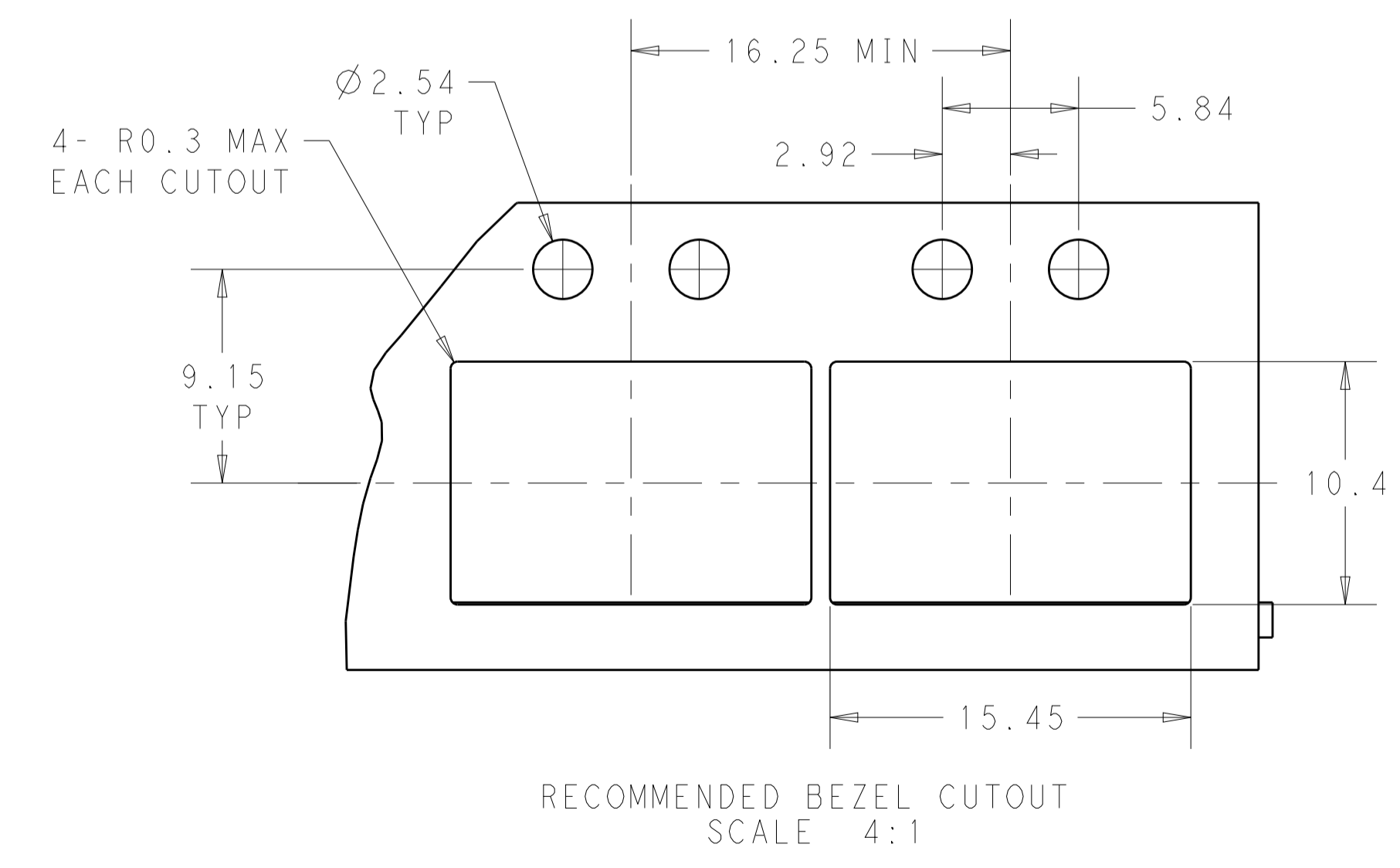

2.90	2274000-2
1.80	2274000-1
DIM A	PART NUMBER

THIS DRAWING IS A CONTROLLED DOCUMENT.

DIMENSIONS:	TOLERANCES UNLESS OTHERWISE SPECIFIED:	DMN: WINDY LIU 08APR2016	CHK: SEAN HAN 08APR2016	APVD: SEAN HAN 08APR2016	NAME: ZSFP+ 1X1 CAGE ASSEMBLY, PRESS-FIT STANDARD, EMI SPRINGS, LIGHTPIPE
mm	0 PLC ±0.1 1 PLC ±0.1 2 PLC ±0.1 3 PLC ±0.05 4 PLC ±0.05 ANGLES ±0.05	PRODUCT SPEC: 108-2364	APPLICATION SPEC: 114-13120	SIZE: CAGE CODE DRAWING NO: A100779C=2274000	RESTRICTED TO: -
MATERIAL:	FINISH:	WEIGHT:	CUSTOMER DRAWING	SCALE: 2:1	SHEET 1 OF 2 REV A

STE TE Connectivity

LOC	DIST	REV	DESCRIPTION	DATE	OWN	APVD
GP	00		SEE SHEET 1			

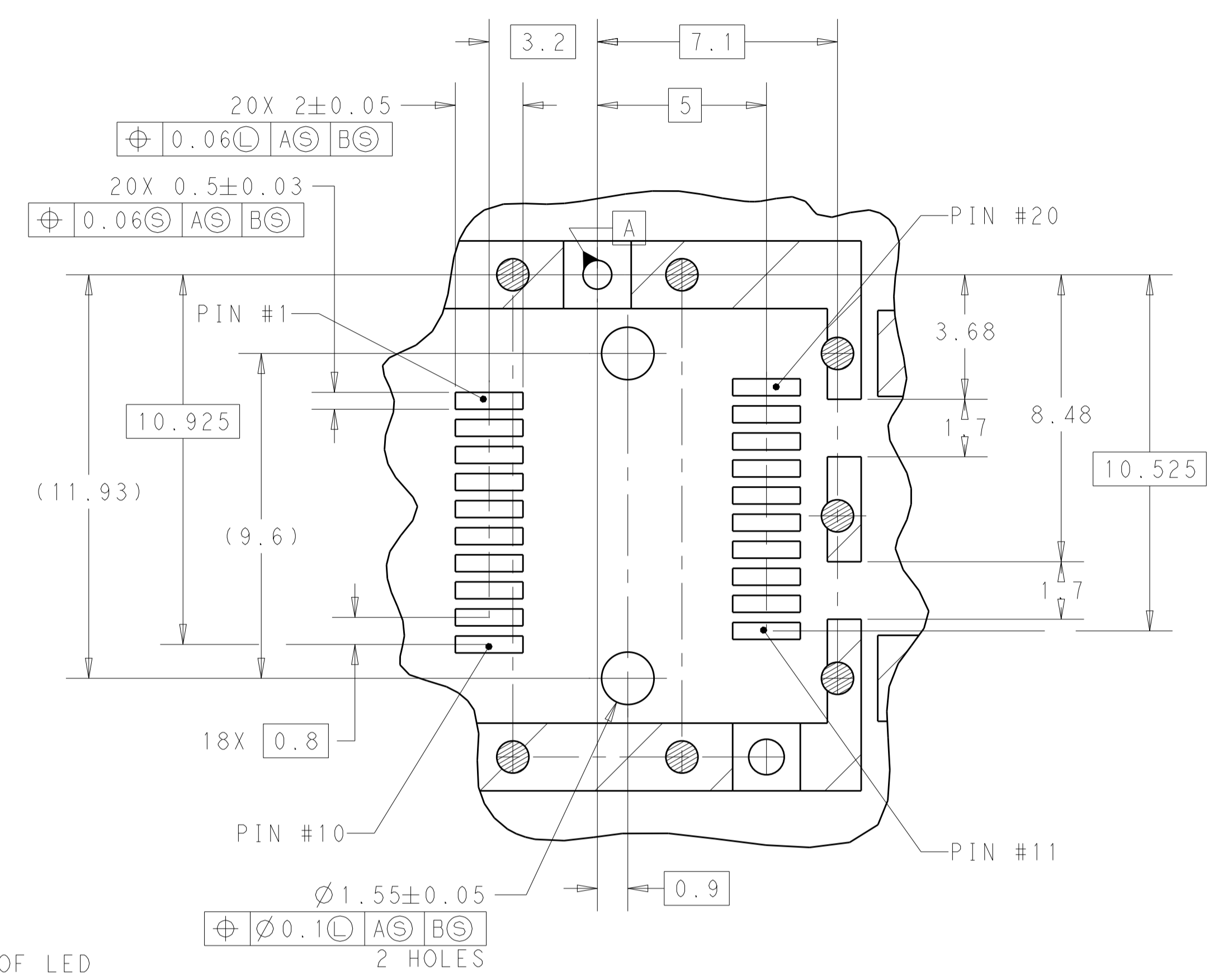
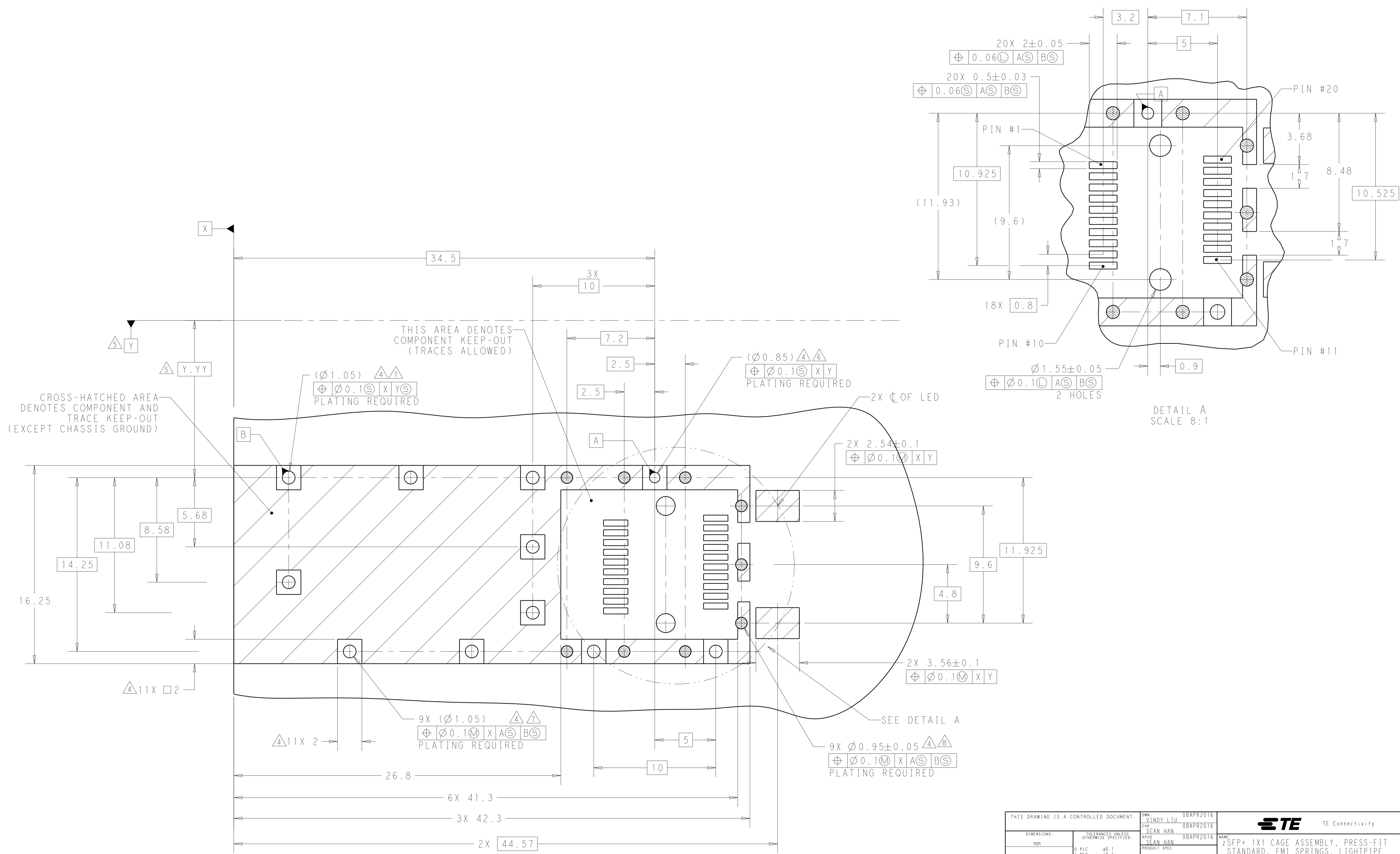

RECOMMENDED PCB LAYOUT  
SCALE 7:1

THIS DRAWING IS A CONTROLLED DOCUMENT.		OWN: VINDY LIU 08APR2016	TE Connectivity
DIMENSIONS: mm		CHK: SEAN HAN 08APR2016	
TOLERANCES UNLESS OTHERWISE SPECIFIED:		APVD: SEAN HAN 08APR2016	NAME: ZSFP+ 1X1 CAGE ASSEMBLY, PRESS-FIT STANDARD, EMI SPRINGS, LIGHTPIPE
0 PLC ±0.1	1 PLC ±0.1	PRODUCT SPEC: 108-2364	SIZE: 114-13120
2 PLC ±0.1	3 PLC ±0.05	APPLICATION SPEC: 114-13120	RESTRICTED TO: A100779C=2274000
4 PLC ±0.05	ANGLES ±0.05	WEIGHT: -	SCALE: 1:1
MATERIAL: FINISH: -	CUSTOMER DRAWING	SHEET 2 OF 2	REV A

## X-ON Electronics

Largest Supplier of Electrical and Electronic Components

*Click to view similar products for [I/O Connectors](#) category:*

*Click to view products by [TE Connectivity](#) manufacturer:*

Other Similar products are found below :

[571763P](#) [72.250.1628.2](#) [72.250.2428.2](#) [74720-0505](#) [76.350.0729.0](#) [76871-1403](#) [FCN-244F080-G/1](#) [FCN-260A9920](#) [MP-5T180MUNNA-005](#)  
[PCR-E36PM](#) [PCS-XE26MA+](#) [G38A71314B](#) [1571250010](#) [157-22500-3](#) [MS3471L14-19P L/C](#) [91-569786-35H](#) [172501-4002](#) [172501-6002](#)  
[FCN-260C008-A/L0](#) [FCN-260C024-AL0](#) [FCN-261Z008](#) [2000314-1](#) [200331-1](#) [PCR-E36FC+](#) [PCS-E28FS+](#) [PCS-XE26SLFD+](#) [PCS-](#)  
[XE26SLFDT+](#) [G730VID08BDC24](#) [U90B2054081210](#) [UE86K842720321](#) [38113800006](#) [DP3AR020WQ1R200](#) [Z4.102.0680.0](#) [500-1040](#)  
[500-1052](#) [500-1054](#) [ZP-4008-66L](#) [0709821002](#) [10-565995-597N](#) [DX40-20P\(55\)](#) [5554841-1](#) [MS3474W18-8P-LC\\*](#) [U90B3054061110](#) [U65-](#)  
[E04-4020](#) [ZPF000000000097891](#) [557-262M2-06C](#) [747360449](#) [10099439-003C-TRLF](#) [10137239-0021LF](#) [E9320-001-01](#)