

THIS DRAWING IS UNPUBLISHED. RELEASED FOR PUBLICATION 20
 © COPYRIGHT 20 BY - ALL RIGHTS RESERVED.

REVISIONS					
P	LTR	DESCRIPTION	DATE	DWN	APVD
A		RELEASED FOR MASS PRODUCTION	23APR2019	TX	SH
A1		REVISED PER ECO-20-001509	20DEC2019	JY/IT	SH
A2		ADDED NEW DASH -7	22DEC2020	AJ	SZ
B		REVISED COVER GASKET SHAPE	30APR2021	AJ	SZ

- 1. MATERIAL :CAGE :0.4MM THICK NICKEL SILVER ALLOY;
EMI SPRING: COPPER ALLOY;
HEAT SINK CLIP: STAINLESS STEEL;
HEAT SINK:ALUMINUM ALLOY;
RECEPTACLE COVER:ZINC ALLOY;
- 2. FINISH: EMI SPRING :1.27um NICKEL PALTING OVER ALL;
HEAT SINK:BLACK ANODIZED COATING;
RECEPTACLE COVER: 1.27um MIN NICKEL PLATING OVER COPPER PLATING;
HEAT SINK CLIP:PASSIVATE;
- 3.MATES WITH CFP MSA COMPLIANT TRANSCEIVERS.
- 4.DATUM AND BASIC DIMENSION ESTABLISHED BY CUSTOMER.
- 5.MINIMUM PC BOARD THICKNESS: SIGLE SIDE APPLICATIONS 2.0MM MIN.
BELLY TO BELLY APPLICATION:3.0MM MIN
- 6.PADS AND VIAS CHASSIS GROUND;
- 7:REFERENCE APPLICATION SOEC 114-32146 FOR
RECOMMENDED DRILL HOLE DIAMETER AND PLATING THICKNESS.
- 8)DATE CODE LOCATED AT APPROXIMATE AREA AS SHOWN.

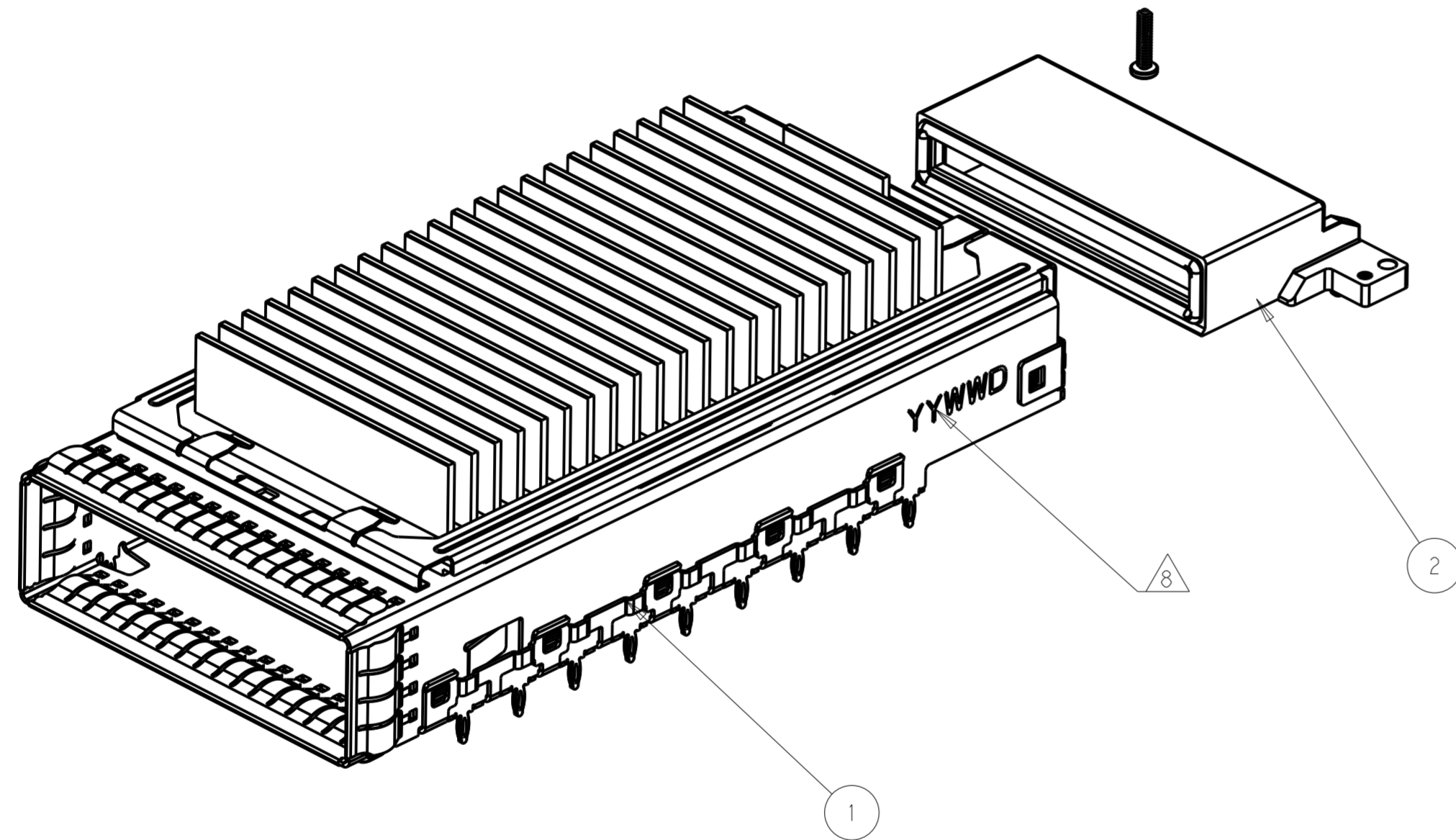

2	2	2	2	2	2	2	2292789-1	SCREW	3
1	1	1	1	1	1	1	2274846-1	RECEPTACLE COVER ASSEMBLY	2
1	-	-	-	-	-	-	1-2293277-0	CAGE ASSEMBLY WITH H/S,CFP2 1X1	1
-	1	-	-	-	-	-	2293277-9	CAGE ASSEMBLY WITH H/S,CFP2 1X1	
-	-	1	-	-	-	-	2293277-8	CAGE ASSEMBLY WITH H/S,CFP2 1X1	
-	-	-	1	-	-	-	2293277-7	CAGE ASSEMBLY WITH H/S,CFP2 1X1	
-	-	-	-	1	-	-	2293277-6	CAGE ASSEMBLY WITH H/S,CFP2 1X1	
-	-	-	-	-	1	-	2293277-2	CAGE ASSEMBLY WITH H/S,CFP2 1X1	
-	-	-	-	-	-	1	2293277-1	CAGE ASSEMBLY WITH H/S,CFP2 1X1	
-7	-6	-5	-4	-3	-2	-1	PAR NUMBER	DESCRIPTION	ITEM

THIS DRAWING IS A CONTROLLED DOCUMENT.		DWN ANDY.XIE 17JUN2015	STE TE Connectivity	
DIMENSIONS: mm		CHK -		
TOLERANCES UNLESS OTHERWISE SPECIFIED:		APVD SEAN.HAN 17JUN2015	NAME HARD WARE KIT FOR CFP2 1X1 PRESS FIT (CAGE,HS,HS CLIP,COVER,SCREW)	
0 PLC ±		PRODUCT SPEC 108-32103	SIZE A2	
1 PLC ±0.25		APPLICATION SPEC 114-32146	CAGE CODE -	
2 PLC ±0.20		WEIGHT -	DRAWING NO G-2274842	
3 PLC ±0.1		CUSTOMER DRAWING	RESTRICTED TO -	
4 PLC ±0.05			SCALE 1:1	
ANGLES ±1			SHEET 1 OF 9	
FINISH SEE NOTES			REV B	

THIS DRAWING IS UNPUBLISHED. RELEASED FOR PUBLICATION 20
 © COPYRIGHT 20 BY - ALL RIGHTS RESERVED.

REVISIONS				
P	LTR	DESCRIPTION	DATE	APVD
-		SEE SHEET 1	-	-

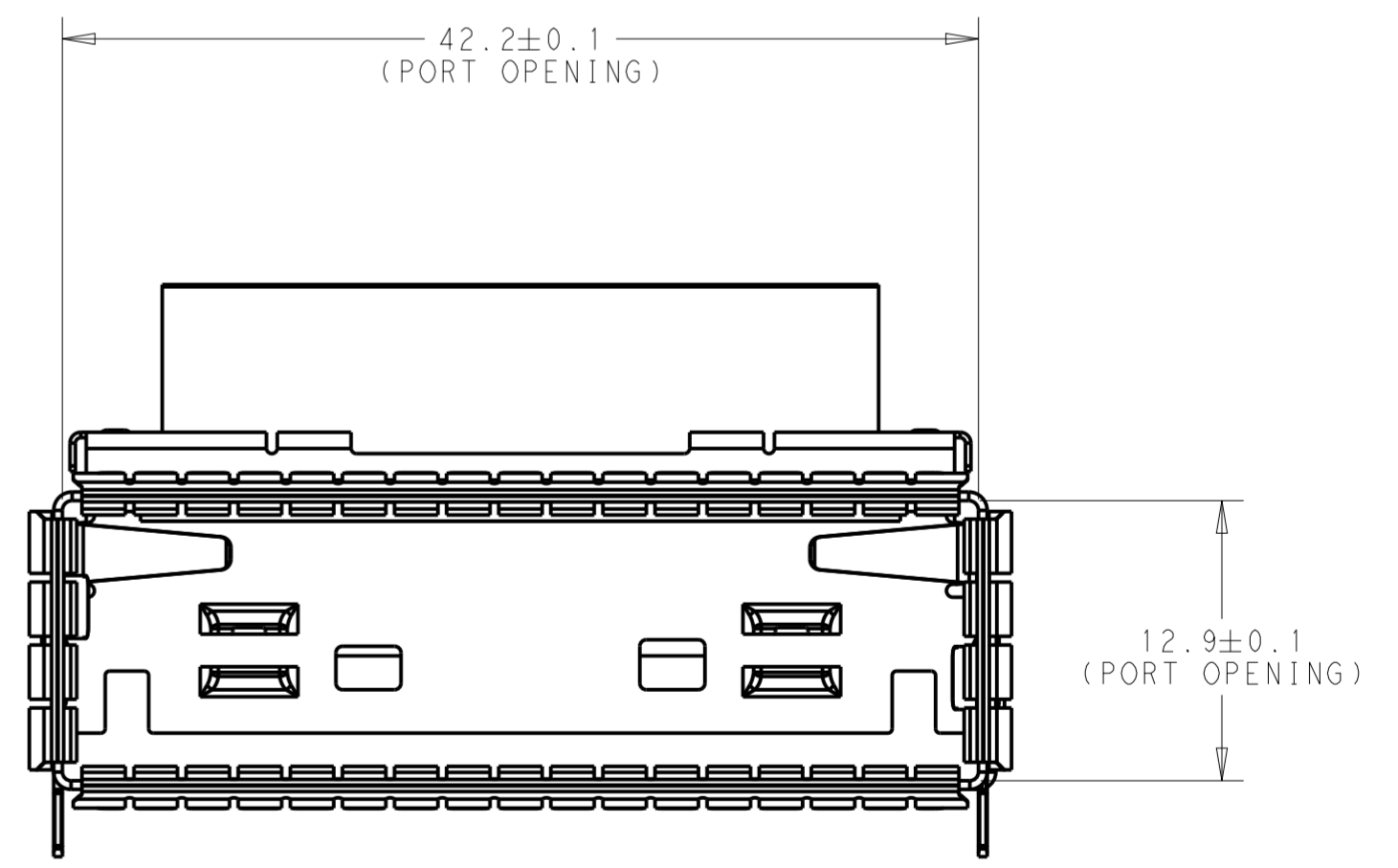
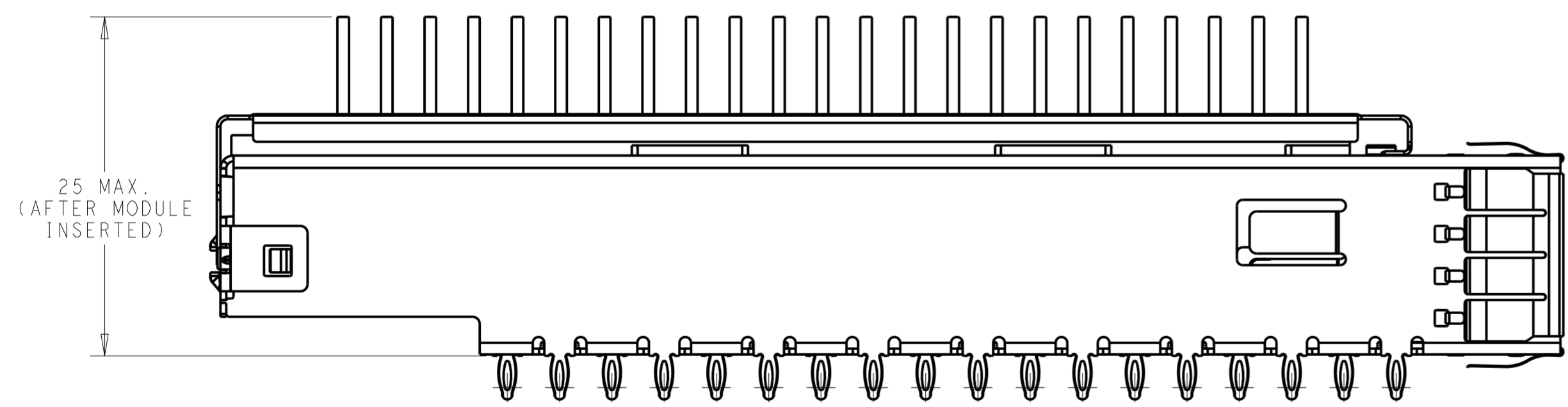
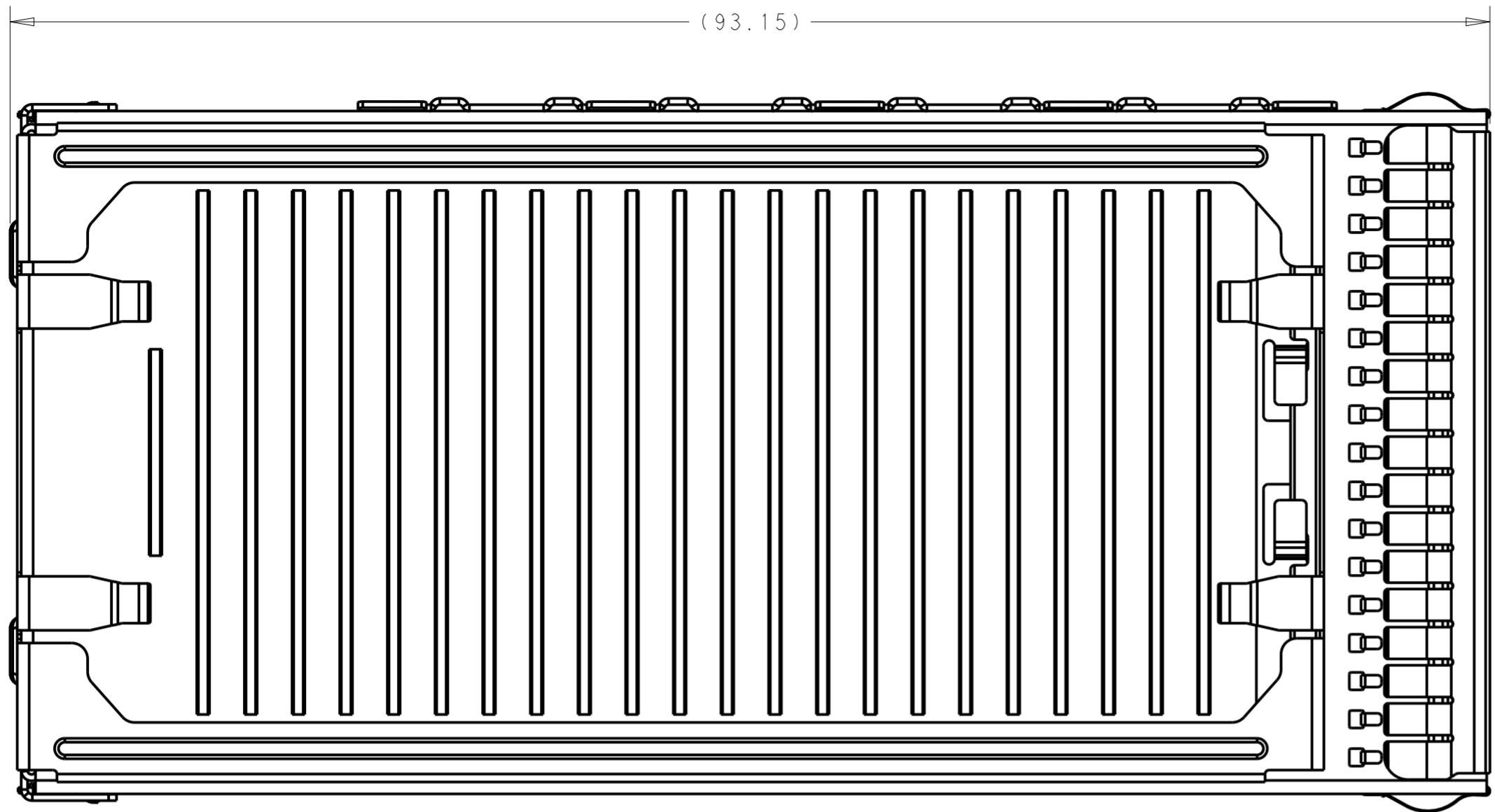

2293277-1 AS SHOWN

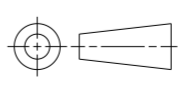
THIS DRAWING IS A CONTROLLED DOCUMENT.		DWN ANDY.XIE 17JUN2015	 TE Connectivity	
DIMENSIONS: mm		CHK -		
		TOLERANCES UNLESS OTHERWISE SPECIFIED: 0 PLC ±- 1 PLC ±0.25 2 PLC ±0.20 3 PLC ±0.1 4 PLC ±0.05 ANGLES ±1 FINISH		APVD SEAN.HAN 17JUN2015
MATERIAL SEE NOTES		PRODUCT SPEC 108-32103 APPLICATION SPEC 114-32146 WEIGHT -		NAME HARD WARE KIT FOR CFP2 1X1 PRESS FIT (CAGE, HS, HS CLIP, COVER, SCREW)
		SIZE A2		CAGE CODE - DRAWING NO. C-2274842
		CUSTOMER DRAWING		RESTRICTED TO - SCALE 1:1 SHEET 2 OF 9 REV B

THIS DRAWING IS UNPUBLISHED. RELEASED FOR PUBLICATION 20
 © COPYRIGHT 20 BY - ALL RIGHTS RESERVED.

REVISIONS				
P	LTR	DESCRIPTION	DATE	APVD
-	-	SEE SHEET 1	-	-

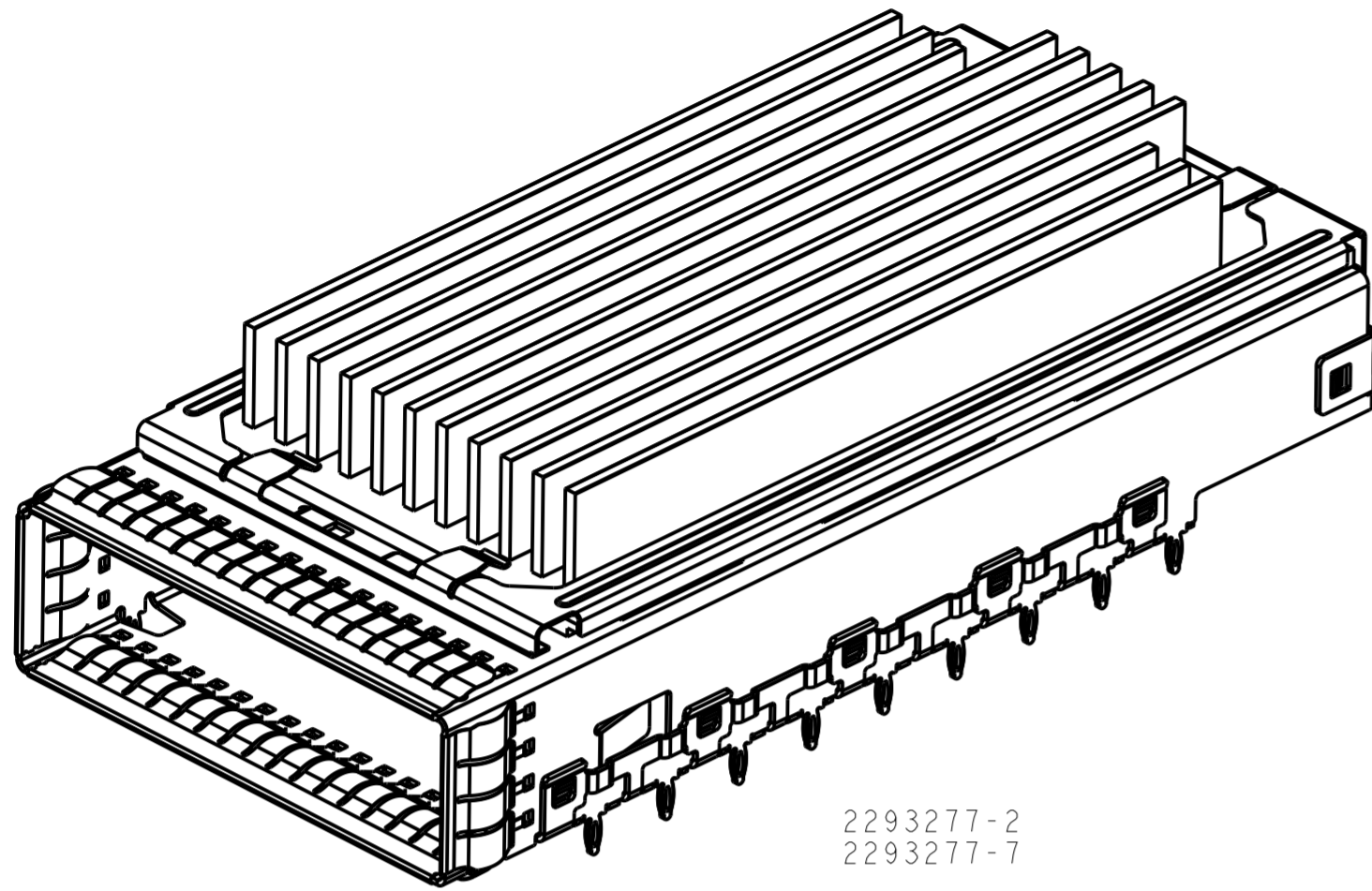

2293277-2
2293277-7

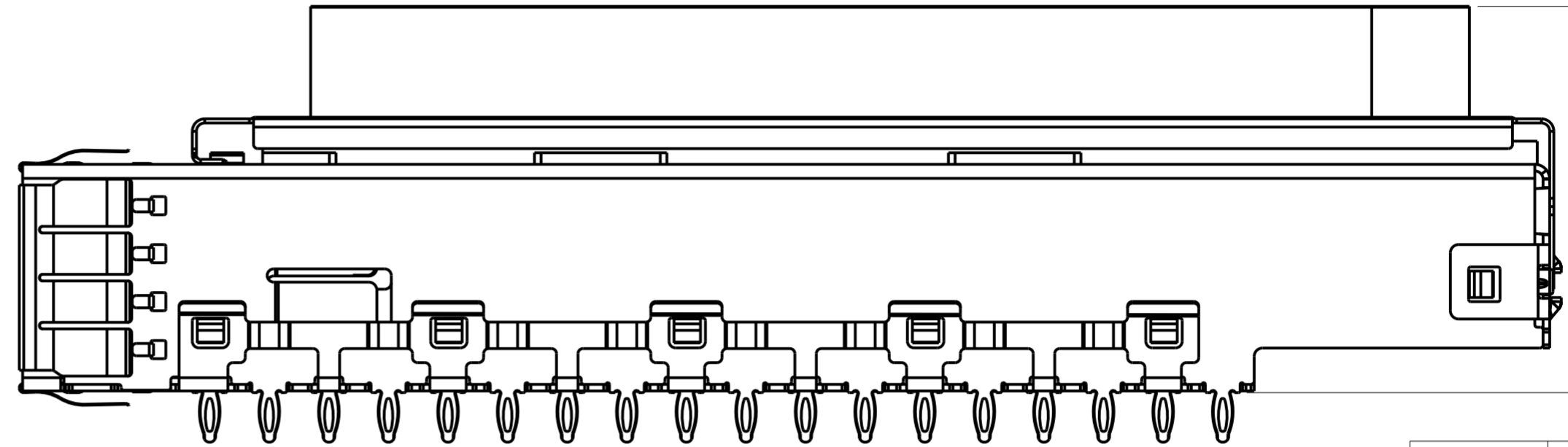

DIM. A MAX.
(AFTER MODULE
INSERTED)

2293277-2&2293277-7/1-2293277-0
OTHER DIMENSIONS
SAME AS 2293277-1
SCALE 3:1

31.85	2293277-7
25	2293277-2
27	1-2293277-0
DIM. A	PART NUMBER

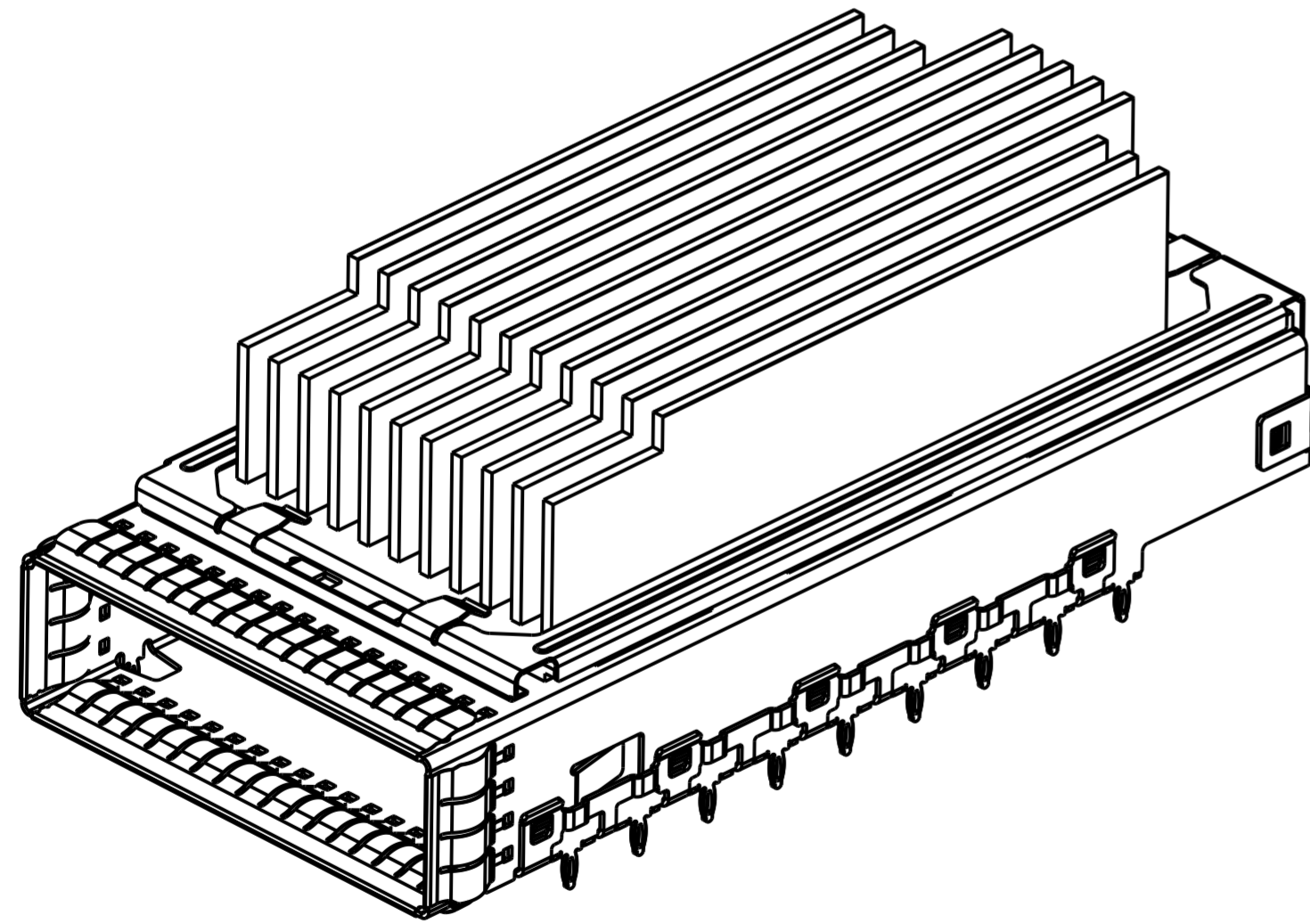

2293277-6

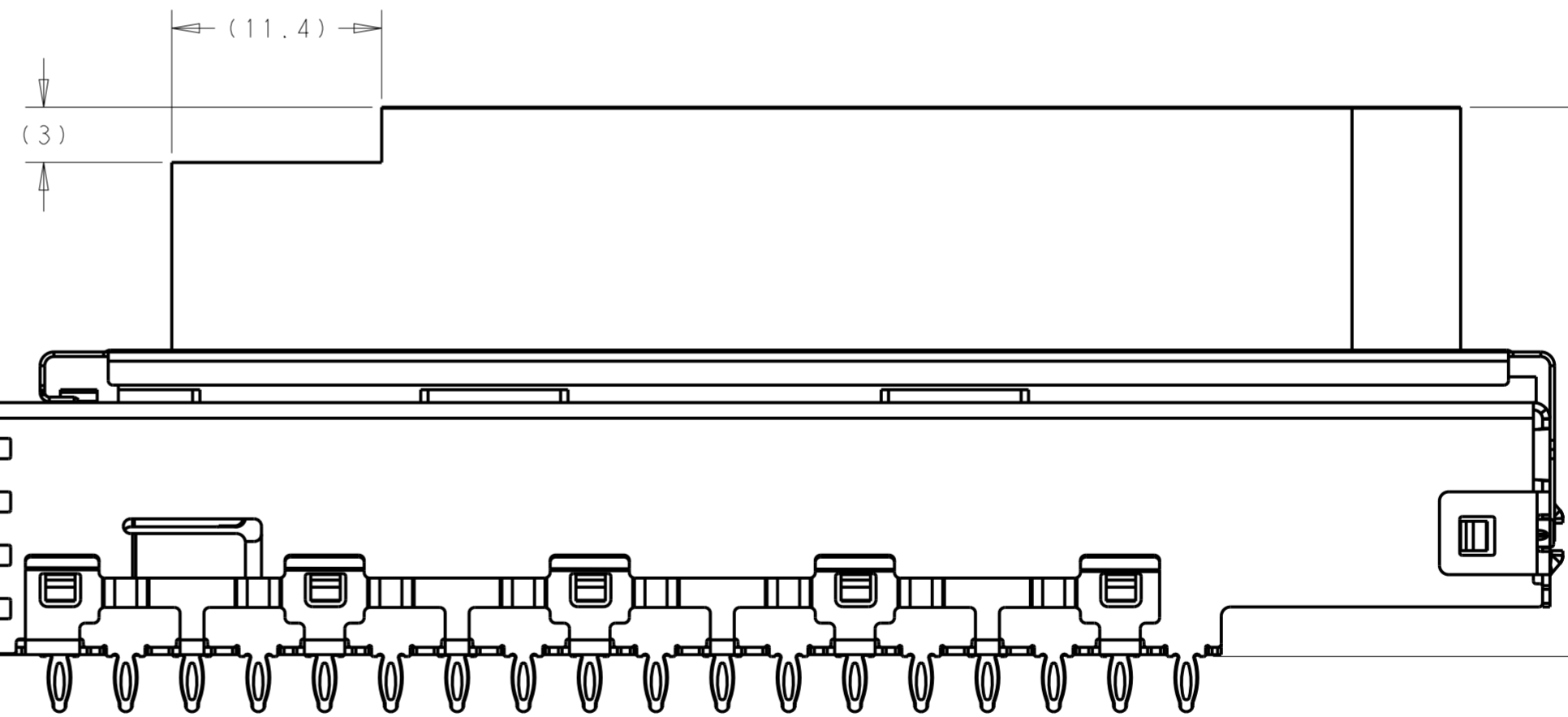

31.2MAX.
(AFTER MODULE
INSERTED)

2293277-6 AS SHOWN, UNSPECIFIED
DIMENSION SAME AS 2293277-1

THIS DRAWING IS A CONTROLLED DOCUMENT.		DWN ANDY.XIE 17JUN2015	TE Connectivity		
DIMENSIONS: mm		CHK -			
		APVD SEAN.HAN 17JUN2015	NAME HARD WARE KIT FOR CFP2 1X1 PRESS FIT (CAGE, HS, HS CLIP, COVER, SCREW)		
TOLERANCES UNLESS OTHERWISE SPECIFIED: 0 PLC ± 1 PLC ±0.25 2 PLC ±0.20 3 PLC ±0.1 4 PLC ±0.05 ANGLES ±1 FINISH		PRODUCT SPEC 108-32103	SIZE A2	CAGE CODE -	DRAWING NO. C-2274842
MATERIAL SEE NOTES		APPLICATION SPEC 114-32146	RESTRICTED TO -	SCALE 1:1	SHEET 3 OF 9
FINISH -		WEIGHT -	CUSTOMER DRAWING	REV B	

THIS DRAWING IS UNPUBLISHED. RELEASED FOR PUBLICATION 20
 © COPYRIGHT 20 BY - ALL RIGHTS RESERVED.

REVISIONS				
P	LTR	DESCRIPTION	DATE	APVD
-		SEE SHEET 1	-	-

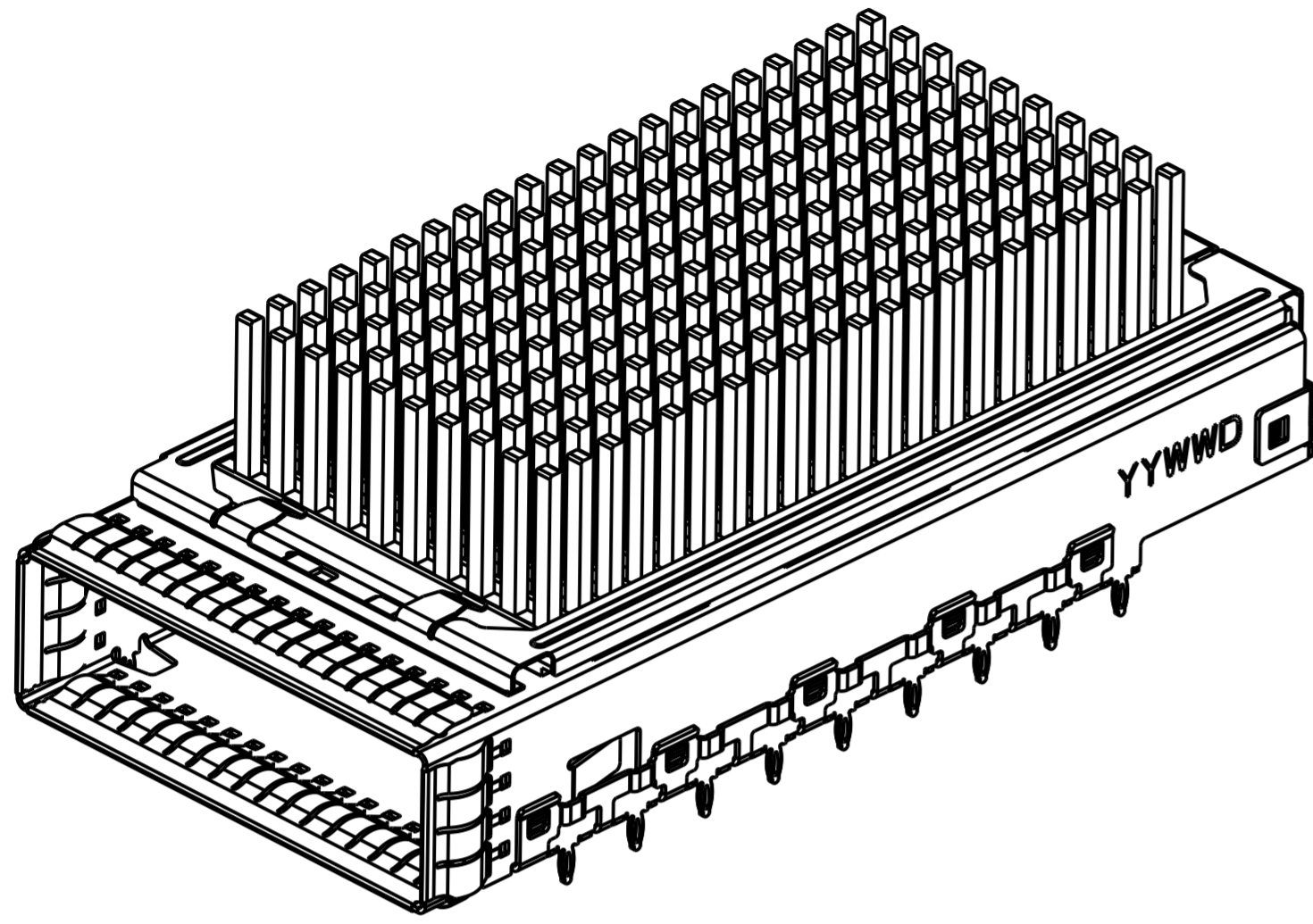

2293277-8 AS SHOWN

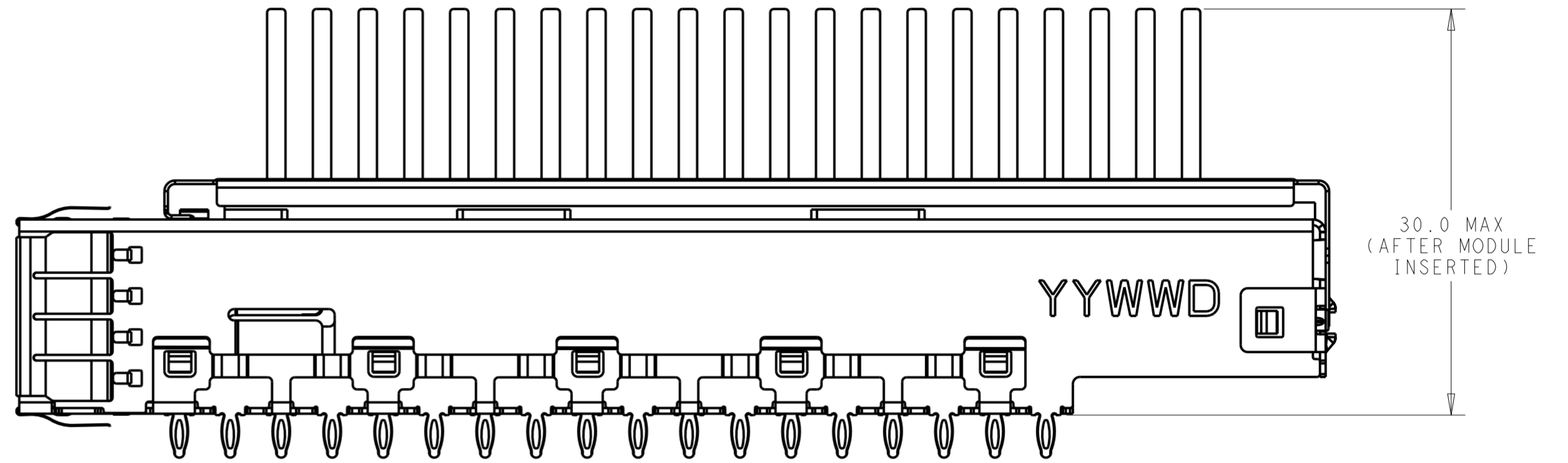

SCALE 3:1

THIS DRAWING IS A CONTROLLED DOCUMENT.		DWN ANDY.XIE 17JUN2015	 TE Connectivity	
DIMENSIONS: mm		CHK -		
TOLERANCES UNLESS OTHERWISE SPECIFIED:		APVD SEAN.HAN 17JUN2015	NAME HARD WARE KIT FOR CFP2 1X1 PRESS FIT (CAGE, HS, HS CLIP, COVER, SCREW)	
0 PLC ±		PRODUCT SPEC 108-32103	SIZE A2	CAGE CODE -
1 PLC ±0.25		APPLICATION SPEC 114-32146	DRAWING NO C-2274842	RESTRICTED TO -
2 PLC ±0.20		WEIGHT -	SCALE 1:1	SHEET 4 OF 9
3 PLC ±0.1		CUSTOMER DRAWING	REV B	
4 PLC ±0.05				
ANGLES ±1				
FINISH				
MATERIAL SEE NOTES	FINISH SEE NOTES			

THIS DRAWING IS UNPUBLISHED. RELEASED FOR PUBLICATION 20
 © COPYRIGHT 20 BY - ALL RIGHTS RESERVED.

REVISIONS					
P	LTR	DESCRIPTION	DATE	DWN	APVD
-	-	SEE SHEET 1	-	-	-

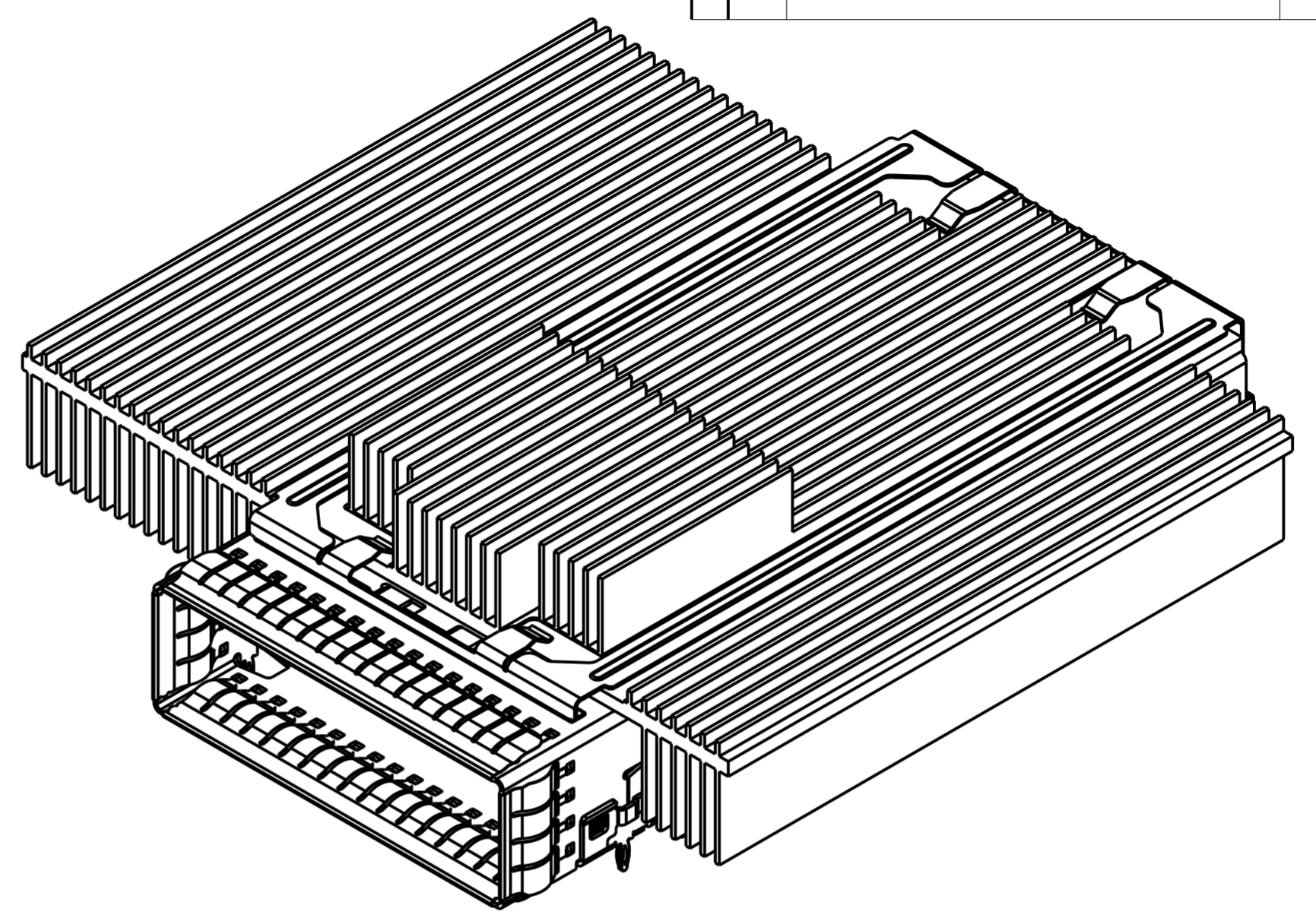
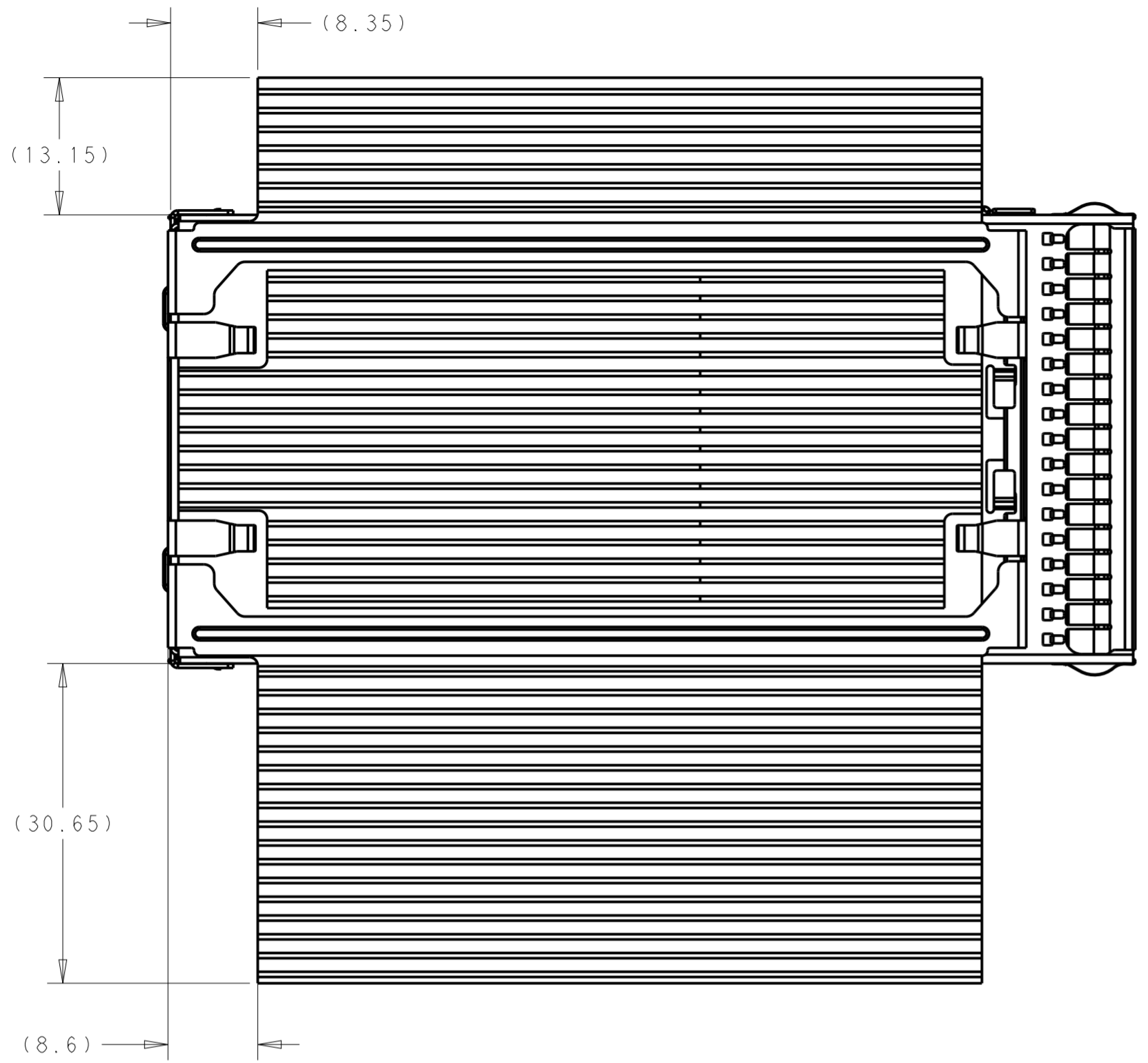

2293277-9 3D VIEW
SCALE 2:1

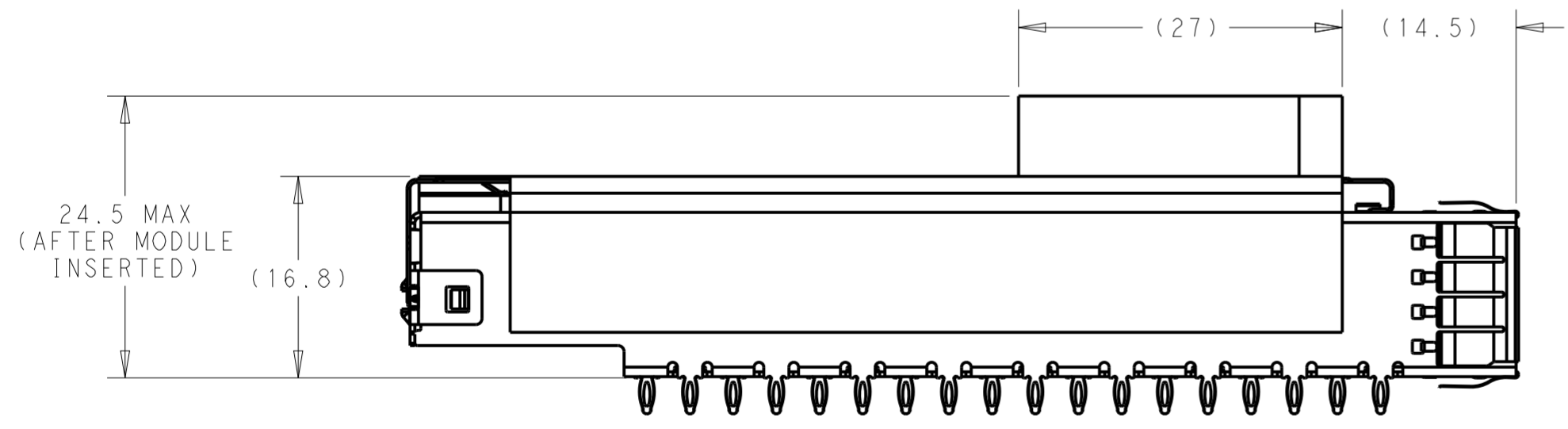

2293277-9 AS SHOWN

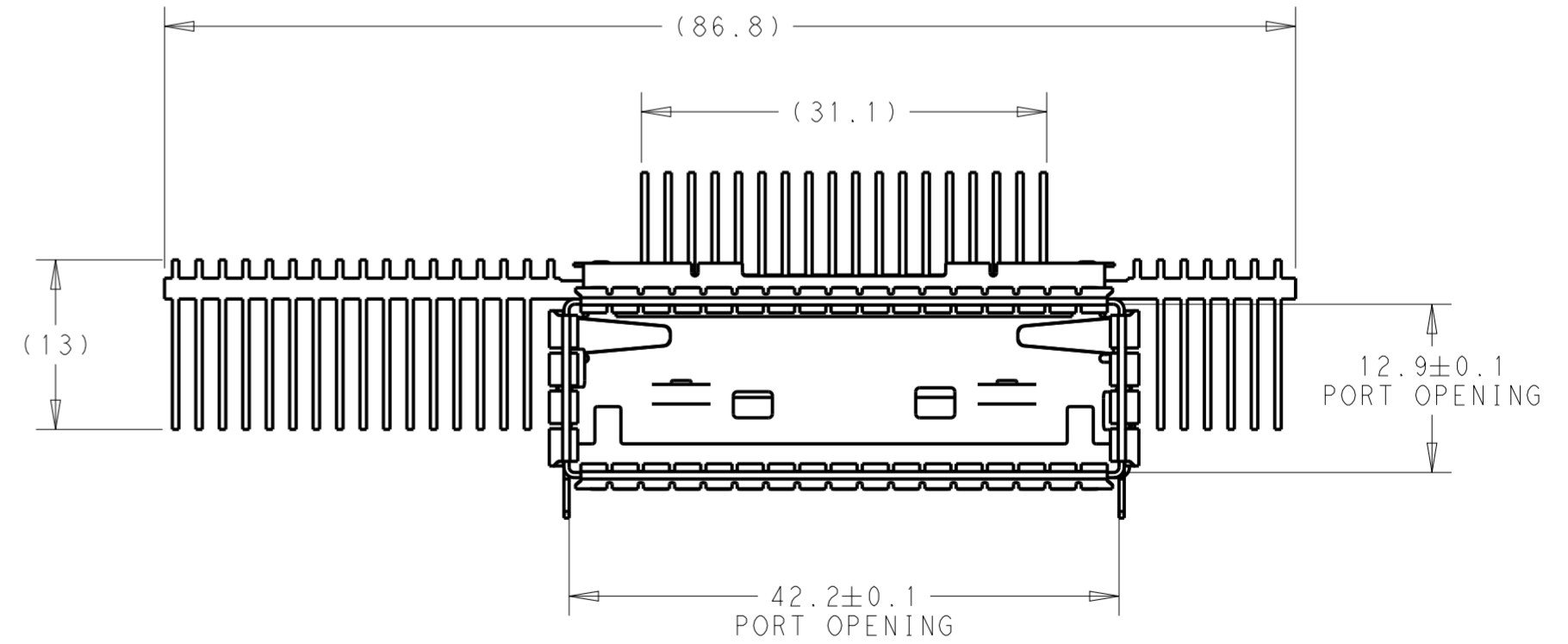

THIS DRAWING IS A CONTROLLED DOCUMENT.		DWN ANDY.XIE 17JUN2015	TE Connectivity	
DIMENSIONS: mm		CHK -		
TOLERANCES UNLESS OTHERWISE SPECIFIED:		APVD SEAN.HAN 17JUN2015	NAME HARD WARE KIT FOR CFP2 1X1 PRESS FIT (CAGE, HS, HS CLIP, COVER, SCREW)	
0 PLC ±		PRODUCT SPEC 108-32103	SIZE A2	CAGE CODE -
1 PLC ±0.25		APPLICATION SPEC 114-32146	DRAWING NO. C-2274842	RESTRICTED TO -
2 PLC ±0.20		WEIGHT -	SCALE 1:1	SHEET 5 OF 9
3 PLC ±0.1		CUSTOMER DRAWING	REV B	
4 PLC ±0.05				
ANGLES ±1				
FINISH SEE NOTES				

THIS DRAWING IS UNPUBLISHED. RELEASED FOR PUBLICATION 20
 © COPYRIGHT 20 BY - ALL RIGHTS RESERVED.

REVISIONS				
P	LTR	DESCRIPTION	DATE	APVD
-		SEE SHEET 1	-	-

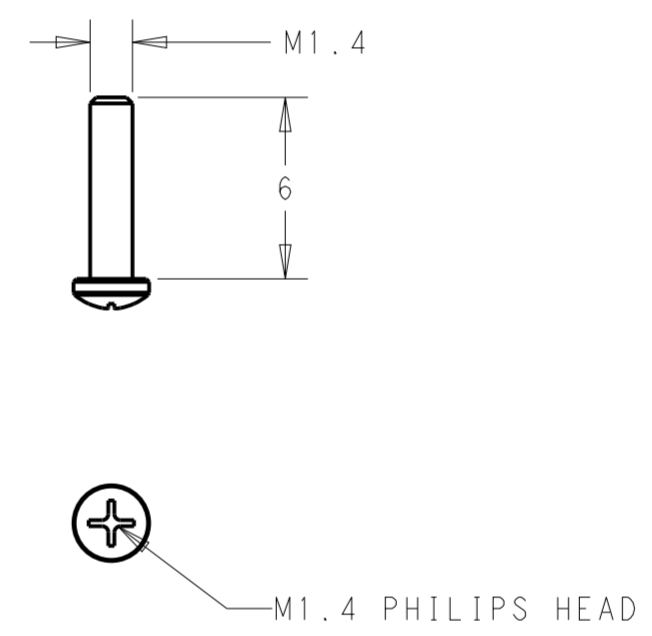
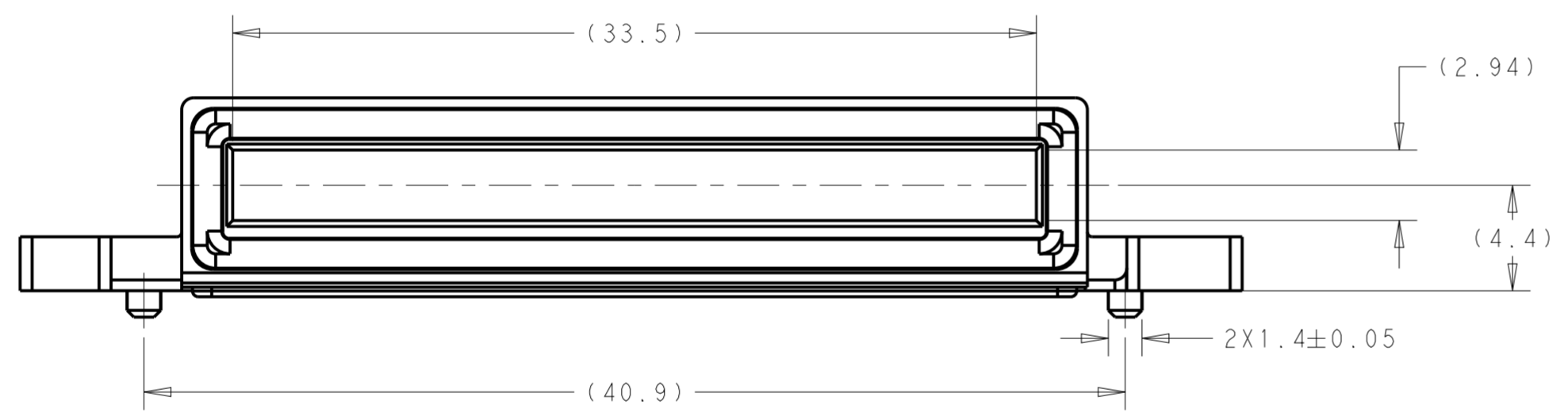
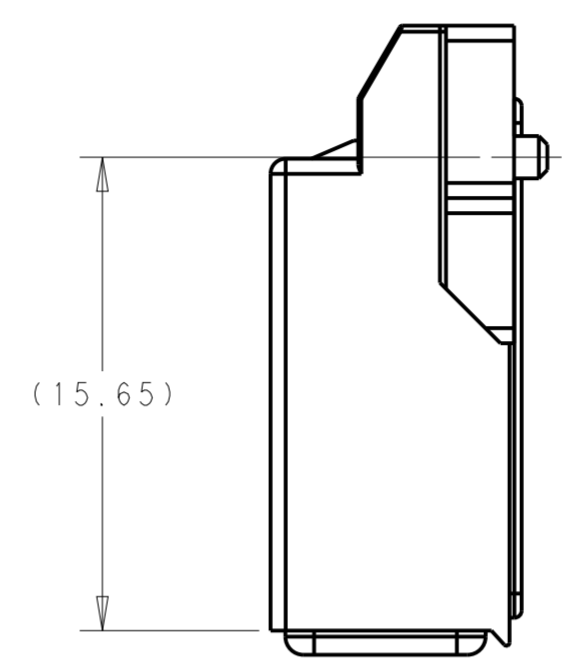
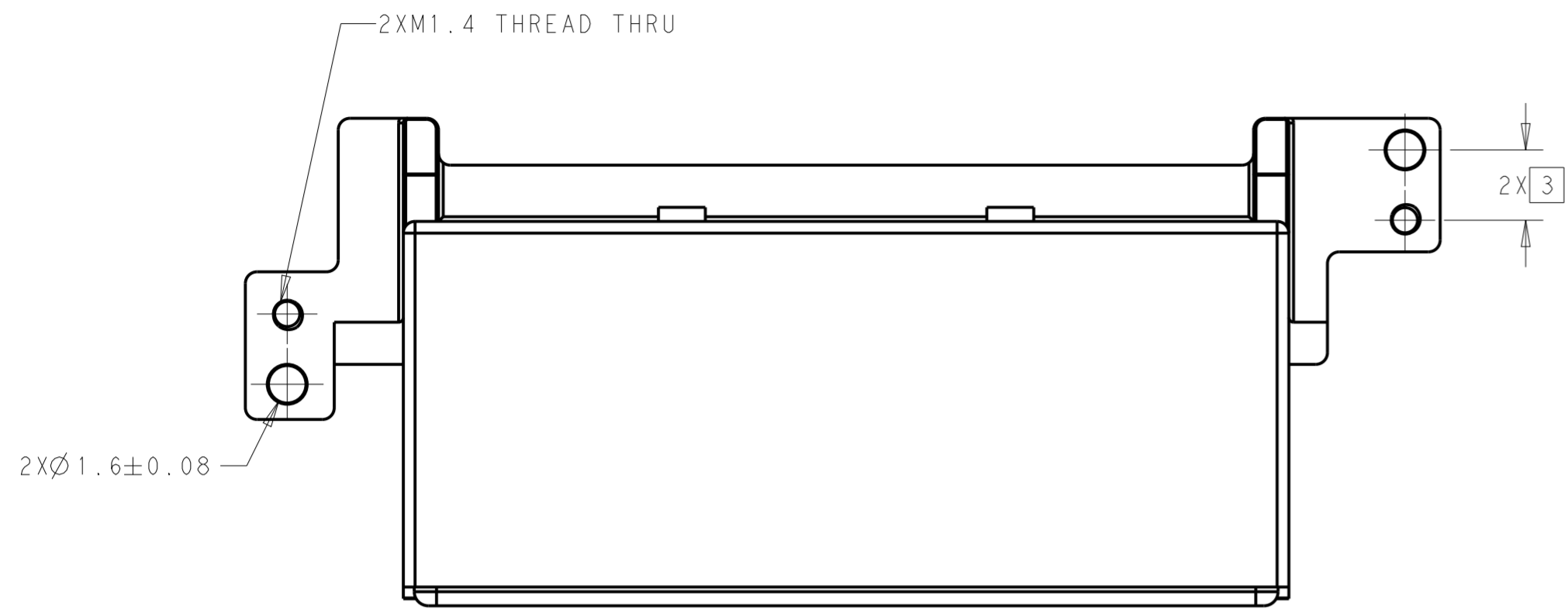

SCALE 4:1

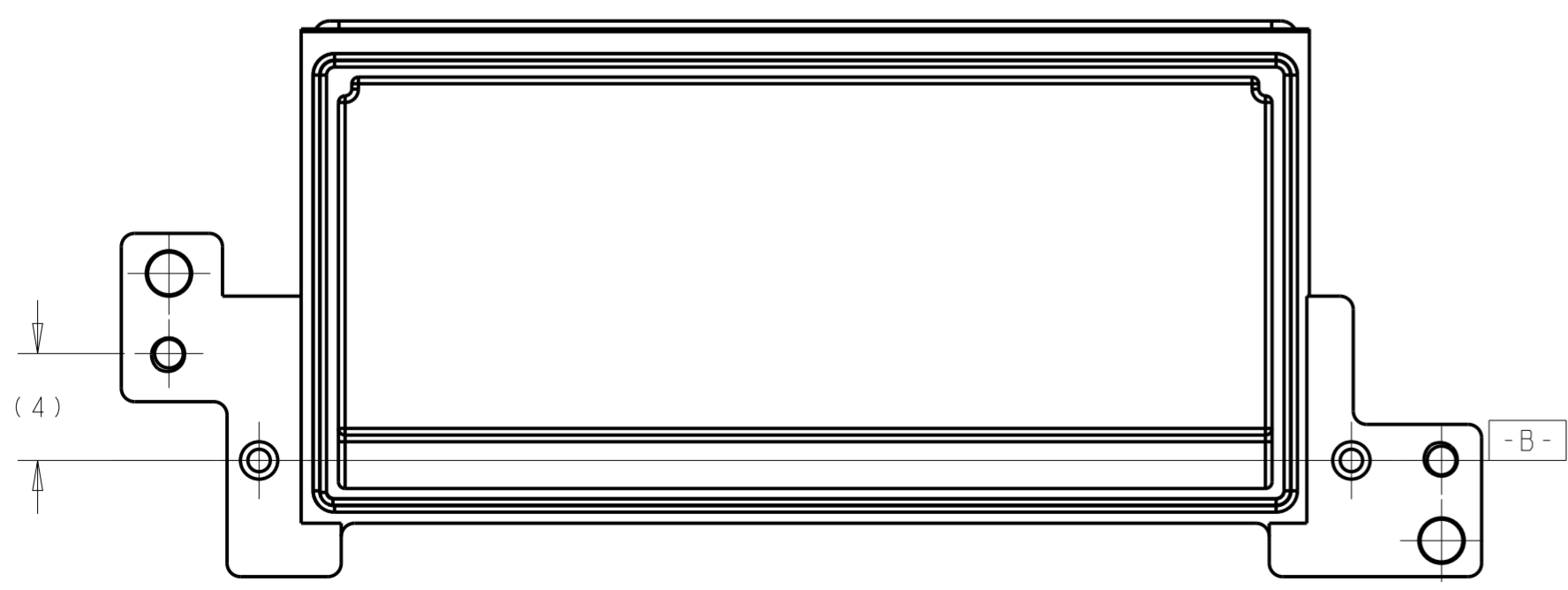

THIS DRAWING IS A CONTROLLED DOCUMENT.		DWN ANDY.XIE 17JUN2015	TE Connectivity	
DIMENSIONS: mm		CHK -		
TOLERANCES UNLESS OTHERWISE SPECIFIED:		APVD SEAN.HAN 17JUN2015	NAME HARD WARE KIT FOR CFP2 1X1	
0 PLC ±		PRODUCT SPEC 108-32103	PRESS FIT	
1 PLC ±0.25		APPLICATION SPEC 114-32146	(CAGE, HS, HS CLIP, COVER, SCREW)	
2 PLC ±0.20		WEIGHT -	SIZE A2	CAGE CODE -
3 PLC ±0.1		CUSTOMER DRAWING	DRAWING NO. C-2274842	RESTRICTED TO -
4 PLC ±0.05			SCALE 1:1	SHEET 6 OF 9
ANGLES ±1				REV B
FINISH				
MATERIAL SEE NOTES				
SEE NOTES				

THIS DRAWING IS UNPUBLISHED. RELEASED FOR PUBLICATION 20
 © COPYRIGHT 20 BY - ALL RIGHTS RESERVED.

REVISIONS					
P	LTR	DESCRIPTION	DATE	DWN	APVD
-	-	SEE SHEET 1	-	-	-

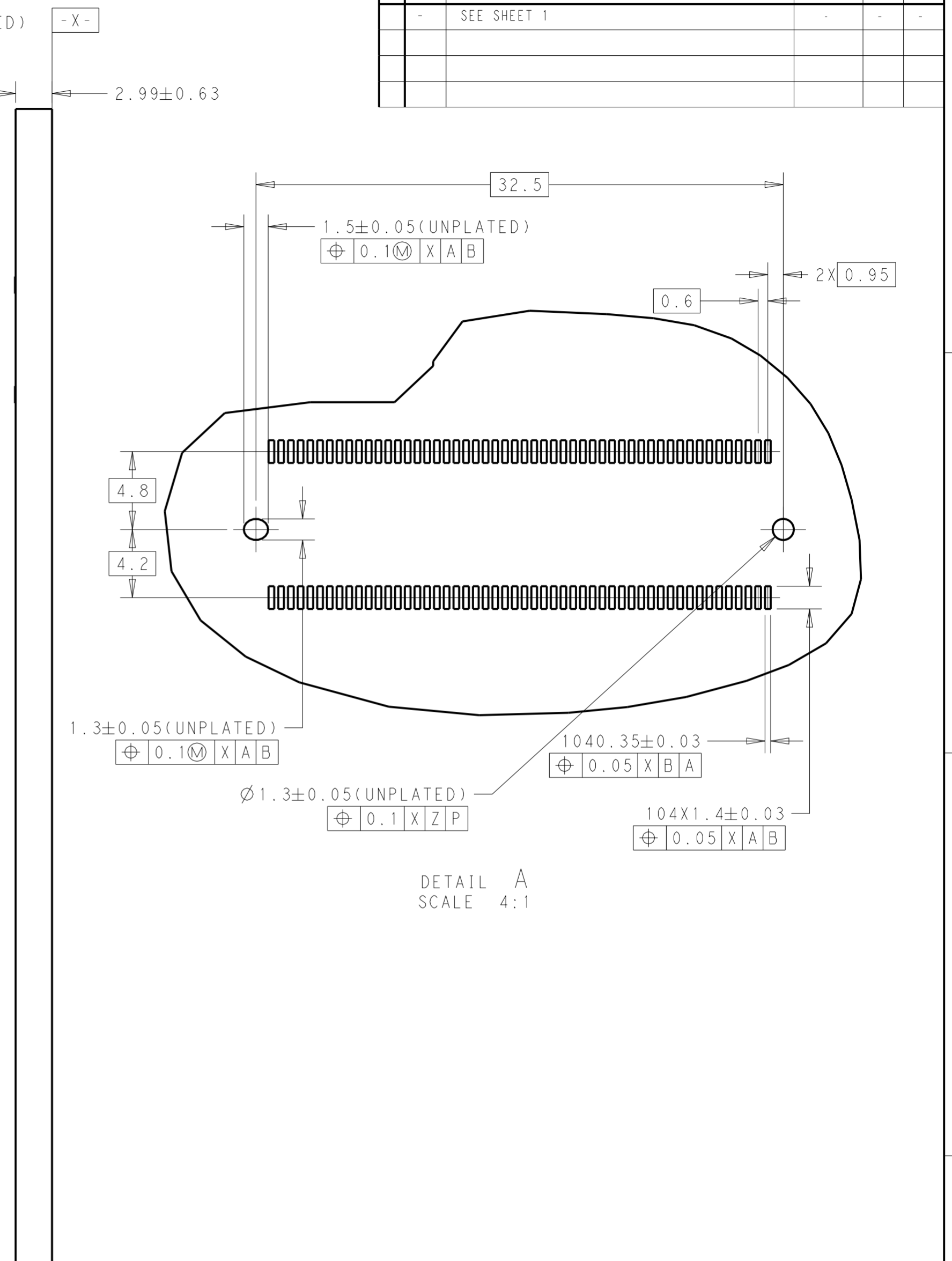
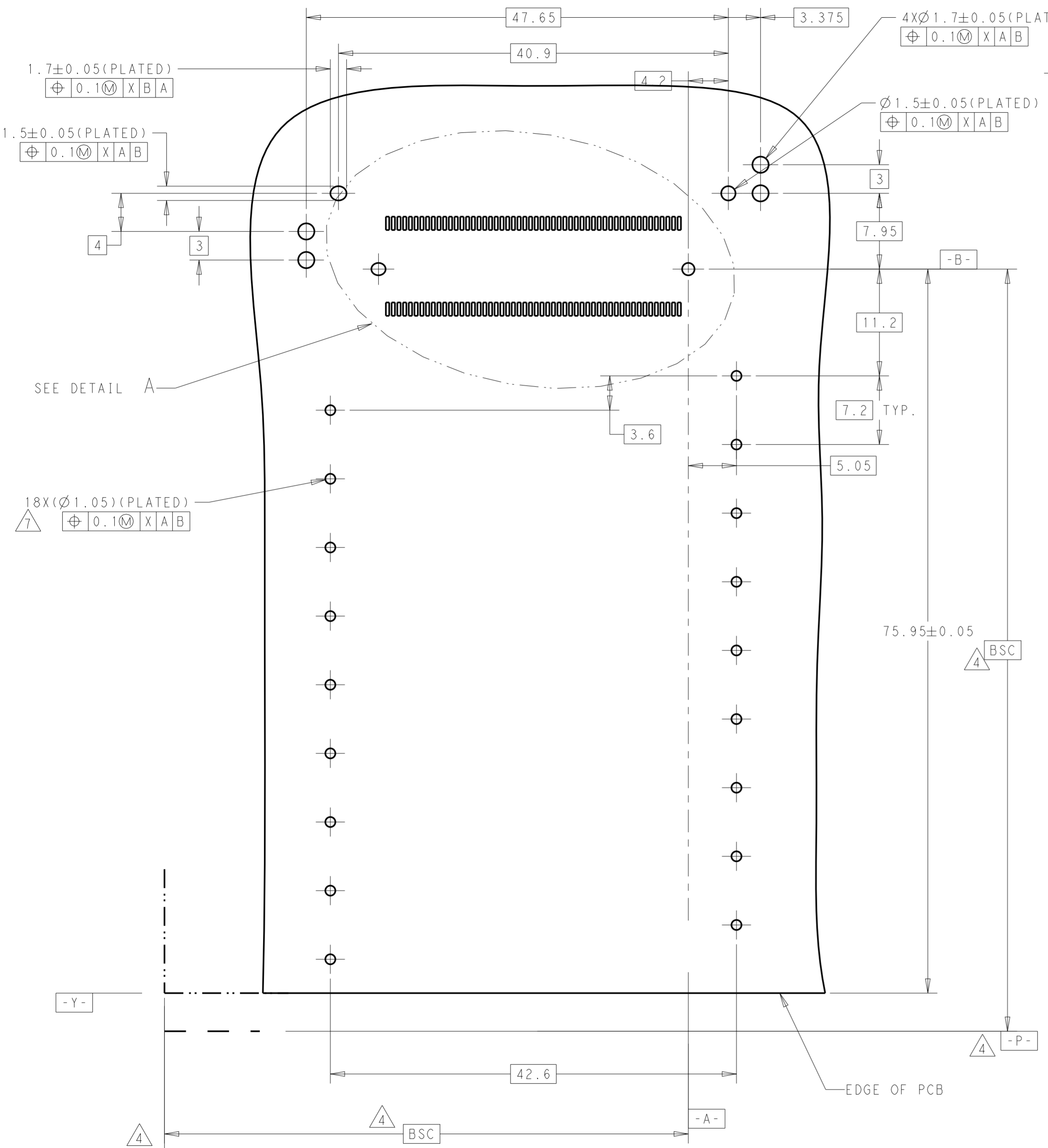

DETAIL A
SCALE 4:1

RECOMMEND PCB LAYOUT, TOLERANCE±0.05
(SINGLE SIDE APPLICATION)

THIS DRAWING IS A CONTROLLED DOCUMENT.		DWN ANDY.XIE 17JUN2015	TE Connectivity		
DIMENSIONS: mm		CHK SEAN.HAN 17JUN2015			
TOLERANCES UNLESS OTHERWISE SPECIFIED:		APVD	NAME HARD WARE KIT FOR CFP2 1X1 PRESS FIT (CAGE, HS, HS CLIP, COVER, SCREW)		
0 PLC ±		PRODUCT SPEC	SIZE A2		
1 PLC ±0.25		APPLICATION SPEC	CAGE CODE -		
2 PLC ±0.20		114-32146	DRAWING NO C-2274842		
3 PLC ±0.1		WEIGHT	RESTRICTED TO -		
4 PLC ±0.05		CUSTOMER DRAWING	SCALE 1:1 SHEET 7 OF 9 REV B		
ANGLES ±1					
FINISH					
MATERIAL SEE NOTES					

THIS DRAWING IS UNPUBLISHED. RELEASED FOR PUBLICATION 20
 © COPYRIGHT 20 BY - ALL RIGHTS RESERVED.

REVISIONS				
P	LTR	DESCRIPTION	DATE	APVD
-		SEE SHEET 1	-	-

CROSS-HATCHED DENOTES COMPONENT AND TRACE KEEP-OUT AREA (EXCEPT CHASSIS GROUND) FOR NON-MAYLARTAPE APPLICATION. COMPONENTS AND TRACES ARE ONLY ALLOWED FOR APPLICATION WITH MYLAR TAPE

EXPOSED PLATED AND SOLDER MASK PULLED BACK (COMPONENT AND TRACE KEEPOUT AREA)

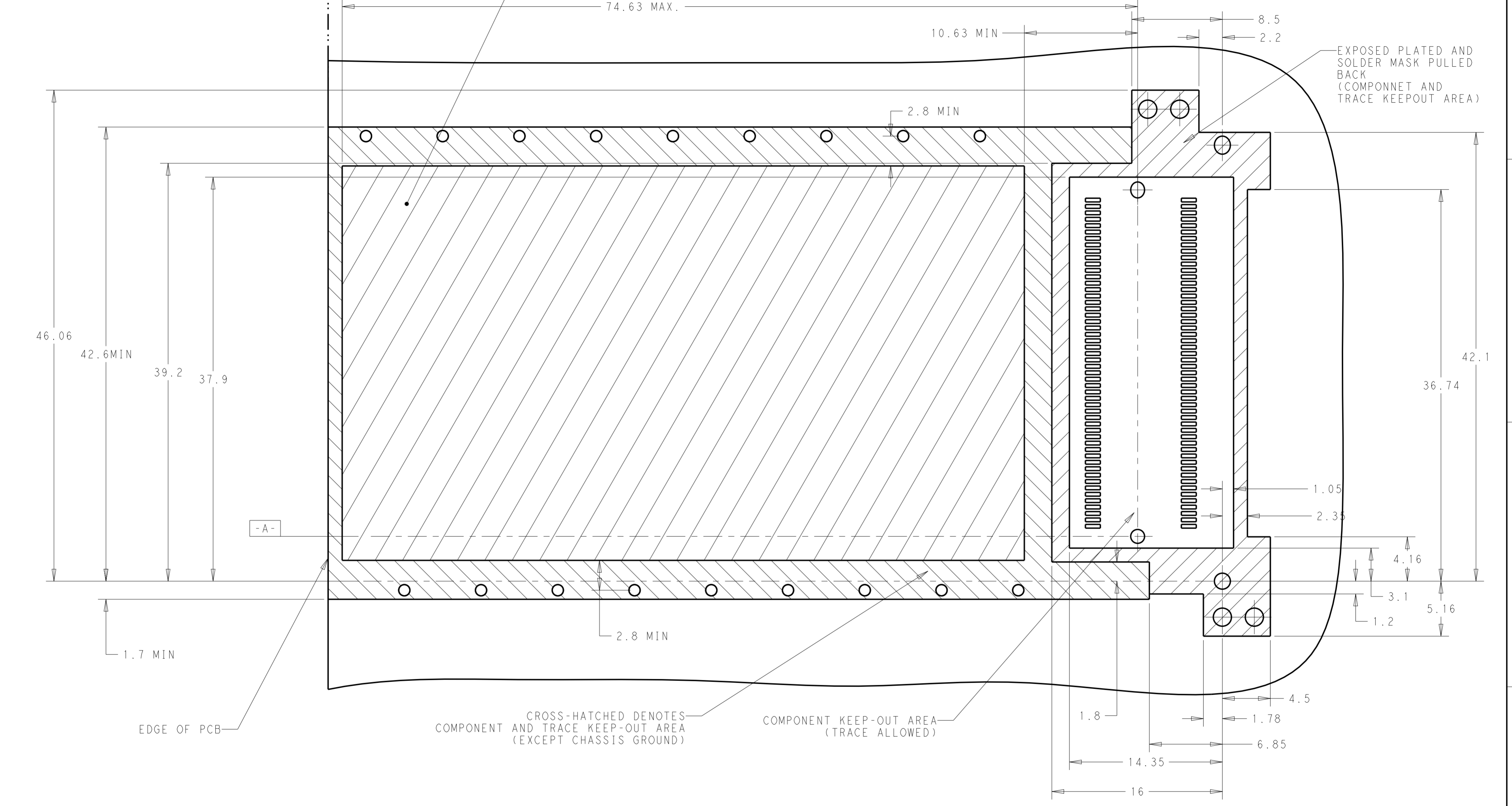

EDGE OF PCB

CROSS-HATCHED DENOTES COMPONENT AND TRACE KEEP-OUT AREA (EXCEPT CHASSIS GROUND)

COMPONENT KEEP-OUT AREA (TRACE ALLOWED)

THIS DRAWING IS A CONTROLLED DOCUMENT.		DWN ANDY.XIE 17JUN2015	TE Connectivity	
DIMENSIONS: mm		CHK -		
TOLERANCES UNLESS OTHERWISE SPECIFIED:		APVD SEAN.HAN 17JUN2015	NAME HARDWARE KIT FOR CFP2 1X1 PRESS FIT (CAGE, HS, HS CLIP, COVER, SCREW)	
0 PLC ±		PRODUCT SPEC 108-32103	SIZE A2	
1 PLC ±0.25		APPLICATION SPEC 114-32146	CAGE CODE -	
2 PLC ±0.20		WEIGHT -	DRAWING NO C-2274842	
3 PLC ±0.1		CUSTOMER DRAWING	RESTRICTED TO -	
4 PLC ±0.05			SCALE 1:1	
ANGLES ±1			SHEET 8 OF 9	
FINISH SEE NOTES			REV B	

THIS DRAWING IS UNPUBLISHED. RELEASED FOR PUBLICATION 20
 © COPYRIGHT 20 BY - ALL RIGHTS RESERVED.

REVISIONS				
P	LTR	DESCRIPTION	DATE	APVD
-	-	SEE SHEET 1	-	-

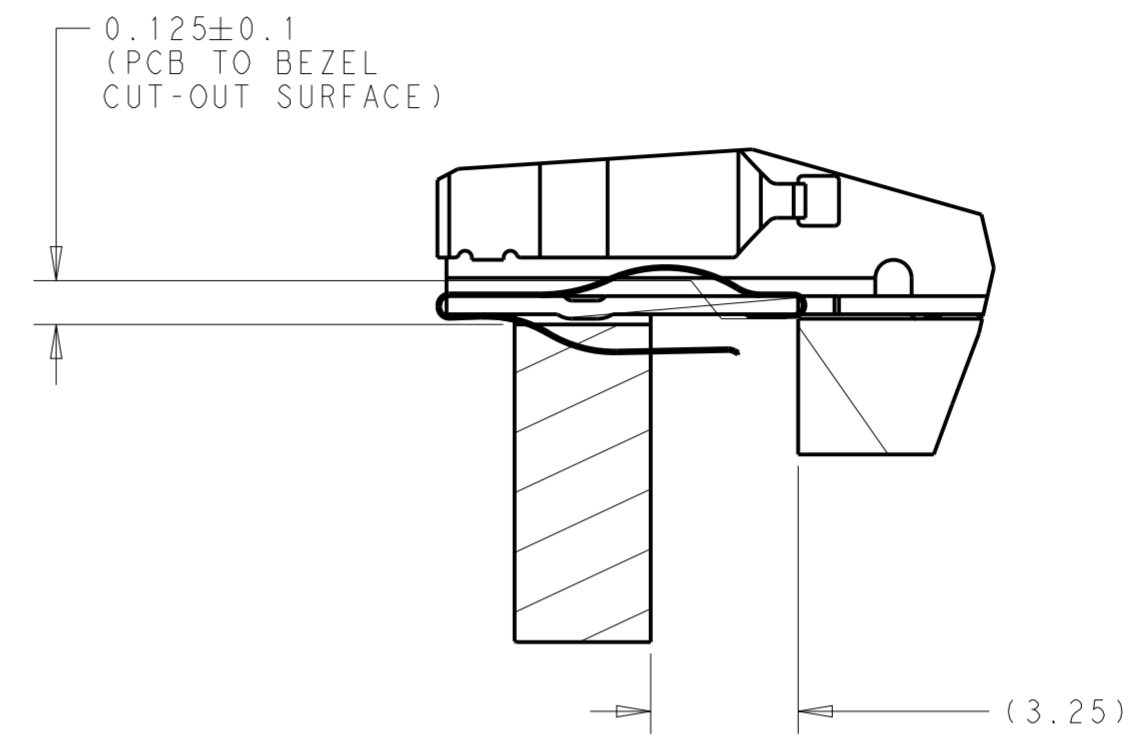
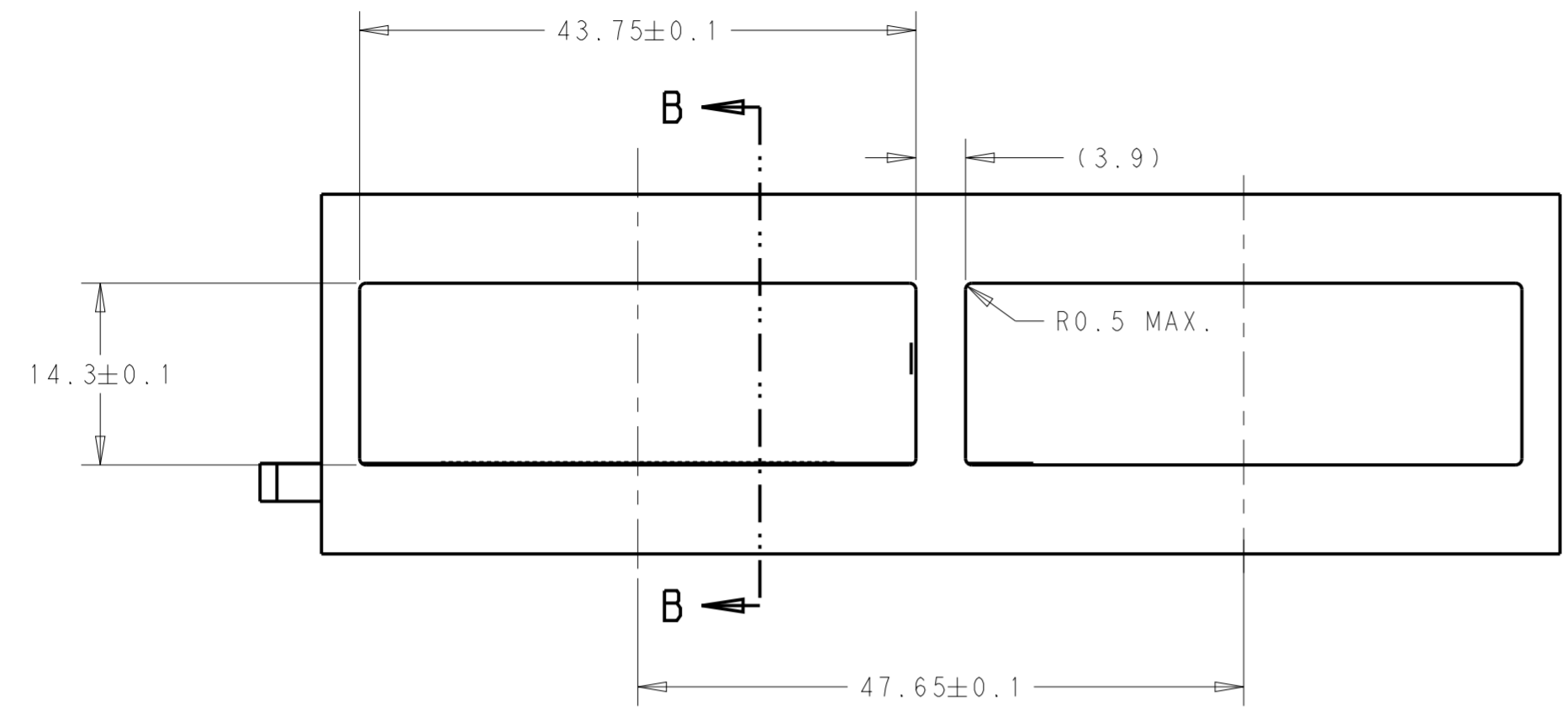

DETAIL B
SCALE 6:1

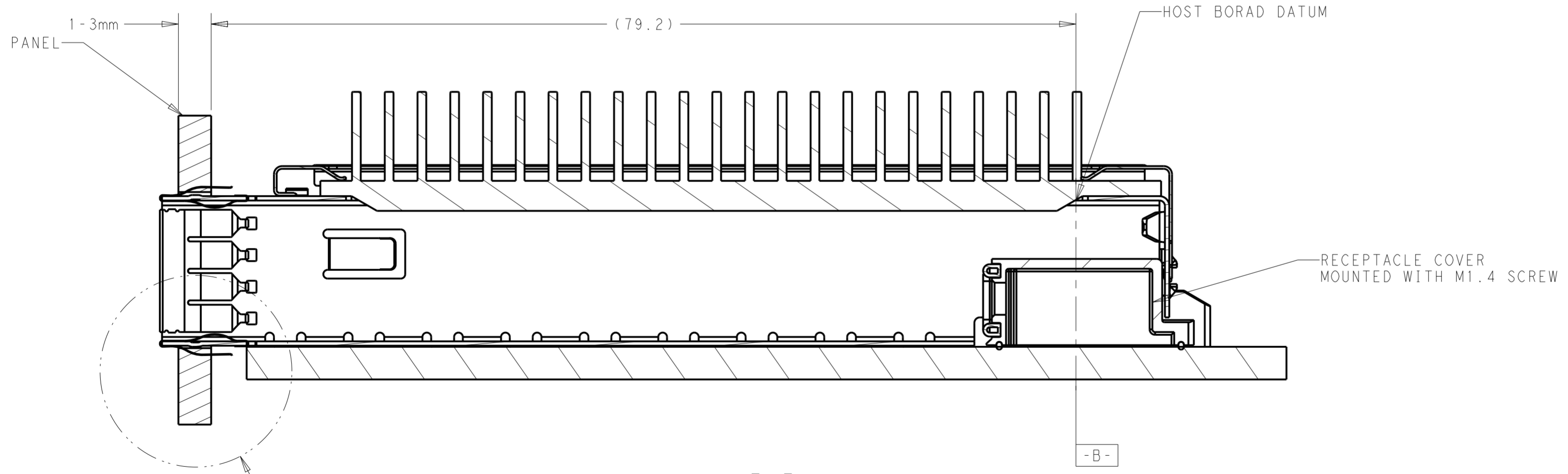

SECTION B-B
SCALE 3:1

SEE DETAIL B

THIS DRAWING IS A CONTROLLED DOCUMENT.		DWN ANDY.XIE 17JUN2015	STE TE Connectivity	
DIMENSIONS: mm		CHK -		
TOLERANCES UNLESS OTHERWISE SPECIFIED:		APVD SEAN.HAN 17JUN2015	NAME HARDWARE KIT FOR CFP2 1X1 PRESS FIT (CAGE, HS, HS CLIP, COVER, SCREW)	
0 PLC ±		PRODUCT SPEC 108-32103	SIZE A2	
1 PLC ±0.25		APPLICATION SPEC 114-32146	CAGE CODE -	
2 PLC ±0.20		WEIGHT -	DRAWING NO. C-2274842	
3 PLC ±0.1		CUSTOMER DRAWING	RESTRICTED TO -	
4 PLC ±0.05			SCALE 1:1 SHEET 9 OF 9 REV B	
ANGLES ±1				
FINISH				
MATERIAL SEE NOTES				
SEE NOTES				

X-ON Electronics

Largest Supplier of Electrical and Electronic Components

Click to view similar products for [I/O Connectors](#) category:

Click to view products by [TE Connectivity](#) manufacturer:

Other Similar products are found below :

[571763P](#) [58098-0628](#) [72.250.1628.2](#) [72.250.2428.2](#) [74720-0505](#) [76.350.0729.0](#) [76871-1403](#) [FCN-244F080-G/1](#) [FCN-260A9920](#) [PCR-E36PM](#) [PCS-XE26MA+](#) [G38A71314B](#) [1571250010](#) [157-22500-3](#) [MS3471L14-19P L/C](#) [172501-4002](#) [172501-6002](#) [FCN-260C008-A/L0](#) [FCN-260C024-AL0](#) [FCN-261Z008](#) [2000314-1](#) [200331-1](#) [PCR-E36FC+](#) [PCS-E28FS+](#) [PCS-XE26SLFD+](#) [PCS-XE26SLFDT+](#) [G730VID08BDC24](#) [U90B2054081210](#) [38113800006](#) [DP3AR020WQ1R200](#) [Z4.102.0680.0](#) [500-1040](#) [500-1052](#) [500-1054](#) [ZP-4008-66L](#) [0709821002](#) [DX40-20P\(55\)](#) [5554841-1](#) [MS3474W18-8P-LC*](#) [U90B3054061110](#) [U65-E04-4020](#) [ZPF000000000097891](#) [747360449](#) [10099439-003C-TRLF](#) [10137239-0021LF](#) [E9320-001-01](#) [10137239-0011LF](#) [70289-001LF](#) [70.060.1028.0](#) [109029-ZZ](#)