

THIS DRAWING IS UNPUBLISHED. RELEASED FOR PUBLICATION 20  
 © COPYRIGHT 20 BY - ALL RIGHTS RESERVED.

REVISIONS				
P	LTR	DESCRIPTION	DATE	APVD
1		PRELIMINARY DRAWING	30MAY2016	AD SH
2		ADD DASH NUMBER	18AUG2016	AD SH
3		ADD PART WIHT MYLAR	14SEP2016	AD SH

- 1 MATERIAL .CAGE -0.4MM THICK NICKEL SILVER AOOY.  
EMI SPRING: COPPER ALLOY;
- 2 .FINISH: EMI SPRING :1.27um NICKEL PALTING OVER ALL;
- 3.MATES WITH CFP MSA COMPLIANT TRANSCEIVERS.
- 4 .DATUM AND BASIC DIMENSION ESTABLISHED BY CUSTOMER.
- 5.MINIMUM PC BOARD THICKNESS: SIGLE SIDE APPLICATIONS=2.99±0.10mm.  
BELLY TO BELLY APPLICATION: 3.0mm MIN.
- 6 .PADS AND VIAS CHASSIS GROUND;
- 7 :REFERENCE APPLICATION SOEC 114-32146,HOLE A, FOR  
RECOMMENDED DRILL HOLE DIAMETER AND PLATING THICKNESS.
- 8 : DATE CODE MARKED IN APPROXIMATE AREA.

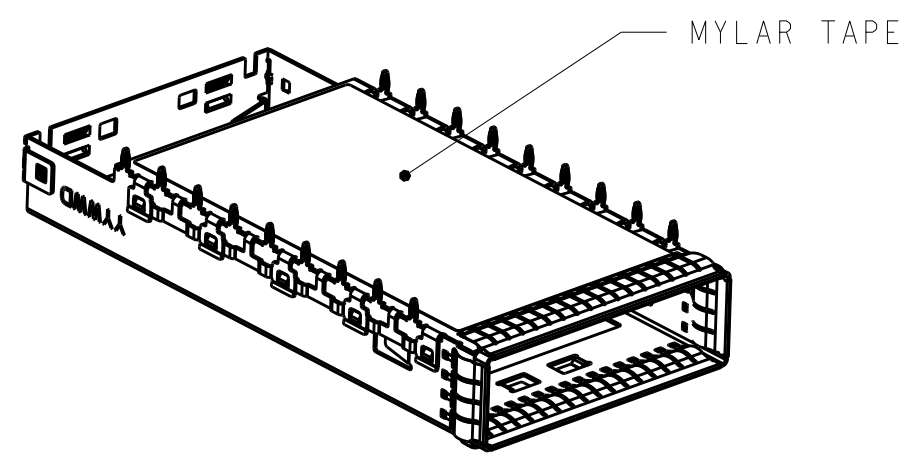
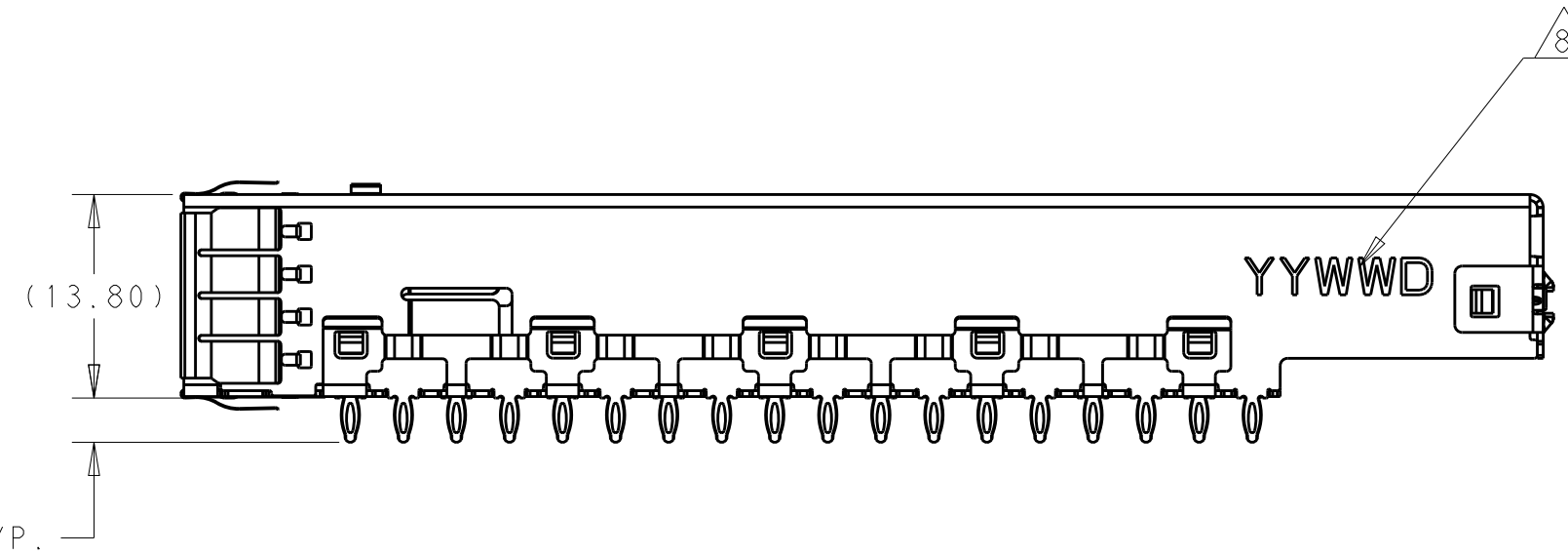
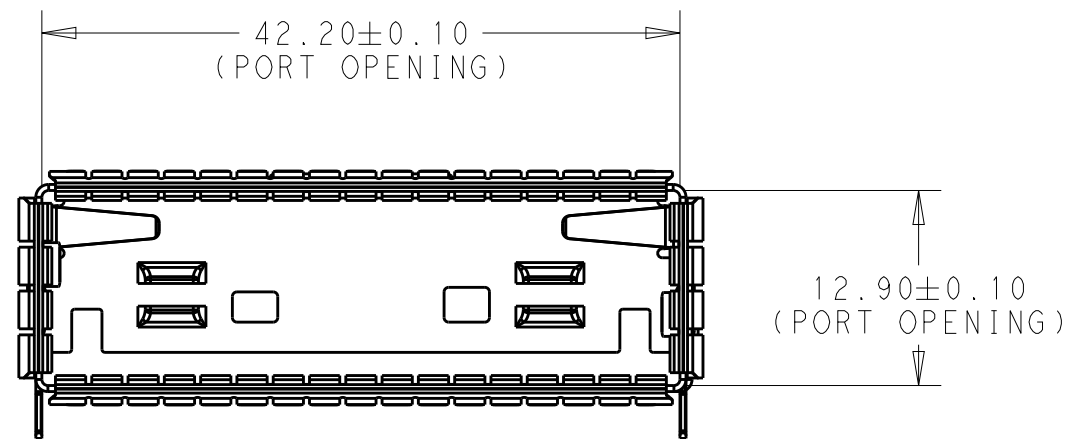
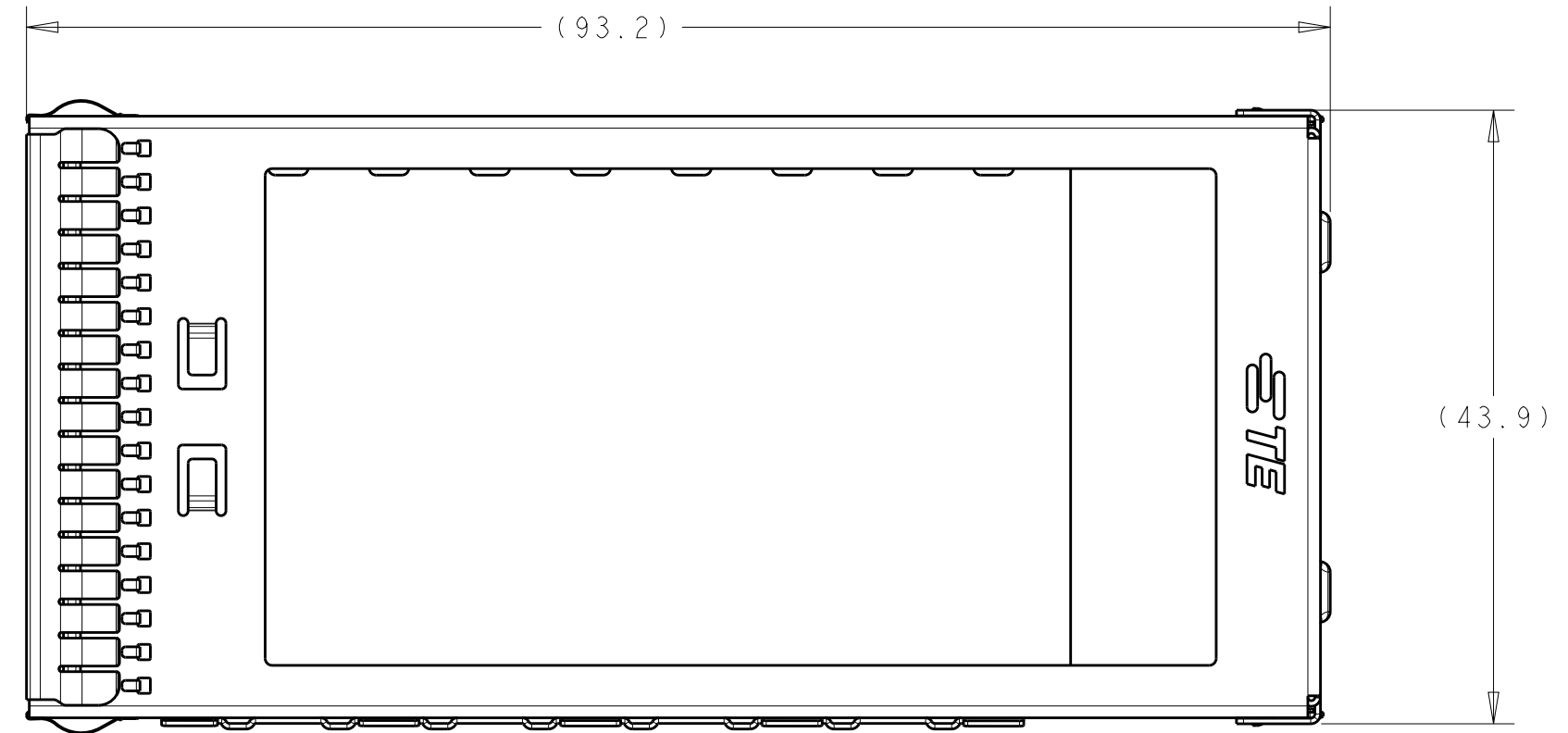

THIS PRINT IS  
**PRELIMINARY**  
 UNQUALIFIED PRODUCT  
 CONTACT PRODUCT ENGINEERING  
 BEFORE USING THIS PRINT

WITH	2274843-4
WITHOUT	2274843-2
MYLAR TAPE	PART NUMBER

THIS DRAWING IS A CONTROLLED DOCUMENT.		DWN ANDY.XIF 30MAY2016	TE Connectivity	
		CHK SEAN.HAN 30MAY2016		
		APVD SEAN.HAN 30MAY2016	NAME CAGE ASSEMBLY, CFP2 1X1 PRESS FIT, EMI SPRING	
DIMENSIONS:		PRODUCT SPEC 108-32103	SIZE A2	
TOLERANCES UNLESS OTHERWISE SPECIFIED:		APPLICATION SPEC 114-32146	CAGE CODE -	
mm		WEIGHT -	DRAWING NO C-2274843	
0 PLC ±		CUSTOMER DRAWING	RESTRICTED TO -	
1 PLC ±0.25		SCALE 1:1	SHEET 1 OF 4	
2 PLC ±0.15			REV 3	
3 PLC ±0.10				
4 PLC ±0.0001				
ANGLES ±				
FINISH				



THIS DRAWING IS UNPUBLISHED. RELEASED FOR PUBLICATION 20  
 © COPYRIGHT 20 BY - ALL RIGHTS RESERVED.

REVISIONS					
P	LTR	DESCRIPTION	DATE	DWN	APVD
-		SEE SHEET 1	-	-	-

CROSS-HATCHED DENOTES COMPONENT AND TRACE KEEP-OUT AREA (EXCEPT CHASSIS GROUND) FOR NON-MAYLARTAPE APPLICATION. COMPONENTS AND TRACES ARE ONLY ALLOWED FOR APPLICATION WITH MYLAR TAPE

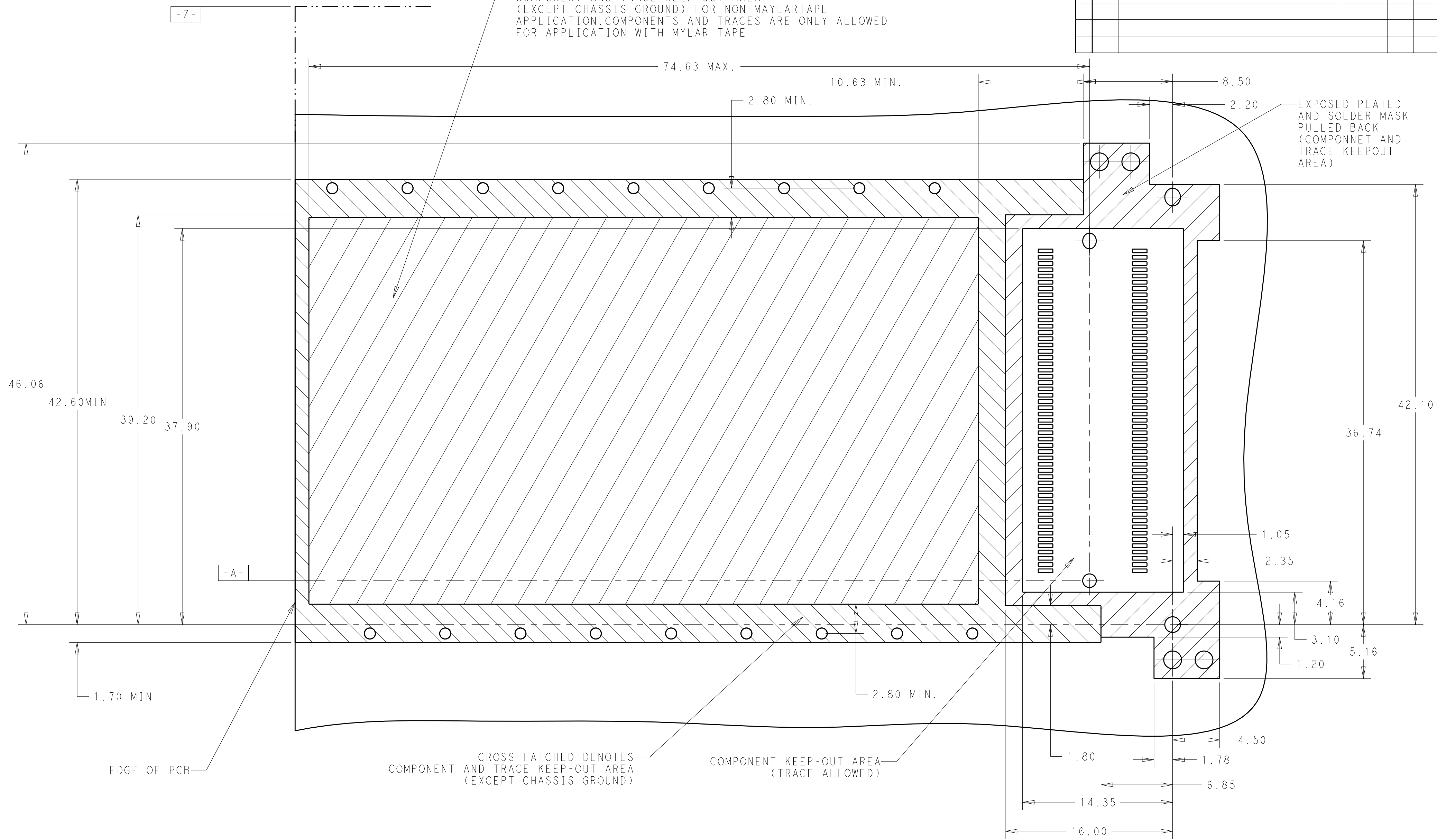

THIS PRINT IS  
**PRELIMINARY**  
 UNQUALIFIED PRODUCT  
 CONTACT PRODUCT ENGINEERING  
 BEFORE USING THIS PRINT

THIS DRAWING IS A CONTROLLED DOCUMENT.		DWN ANDY.XIF 30MAY2016	TE Connectivity		
DIMENSIONS: mm		CHK SEAN.HAN 30MAY2016			
TOLERANCES UNLESS OTHERWISE SPECIFIED:		APVD SEAN.HAN 30MAY2016	NAME CAGE ASSEMBLY, CFP2 1X1 PRESS FIT, EMI SPRING		
0 PLC ±0.10		PRODUCT SPEC	SIZE A2		
1 PLC ±0.10		APPLICATION SPEC	CAGE CODE -		
2 PLC ±0.10		WEIGHT	DRAWING NO C-2274843		
3 PLC ±0.10		Customer Drawing	RESTRICTED TO -		
4 PLC ±0.05			SCALE 1:1		
ANGLES ±1			SHEET 3 OF 4		
FINISH			REV 3		
MATERIAL SEE NOTES					

THIS DRAWING IS UNPUBLISHED. RELEASED FOR PUBLICATION 20  
 © COPYRIGHT 20 BY - ALL RIGHTS RESERVED.

REVISIONS				
P	LTR	DESCRIPTION	DATE	APVD
-	-	SEE SHEET 1	-	-

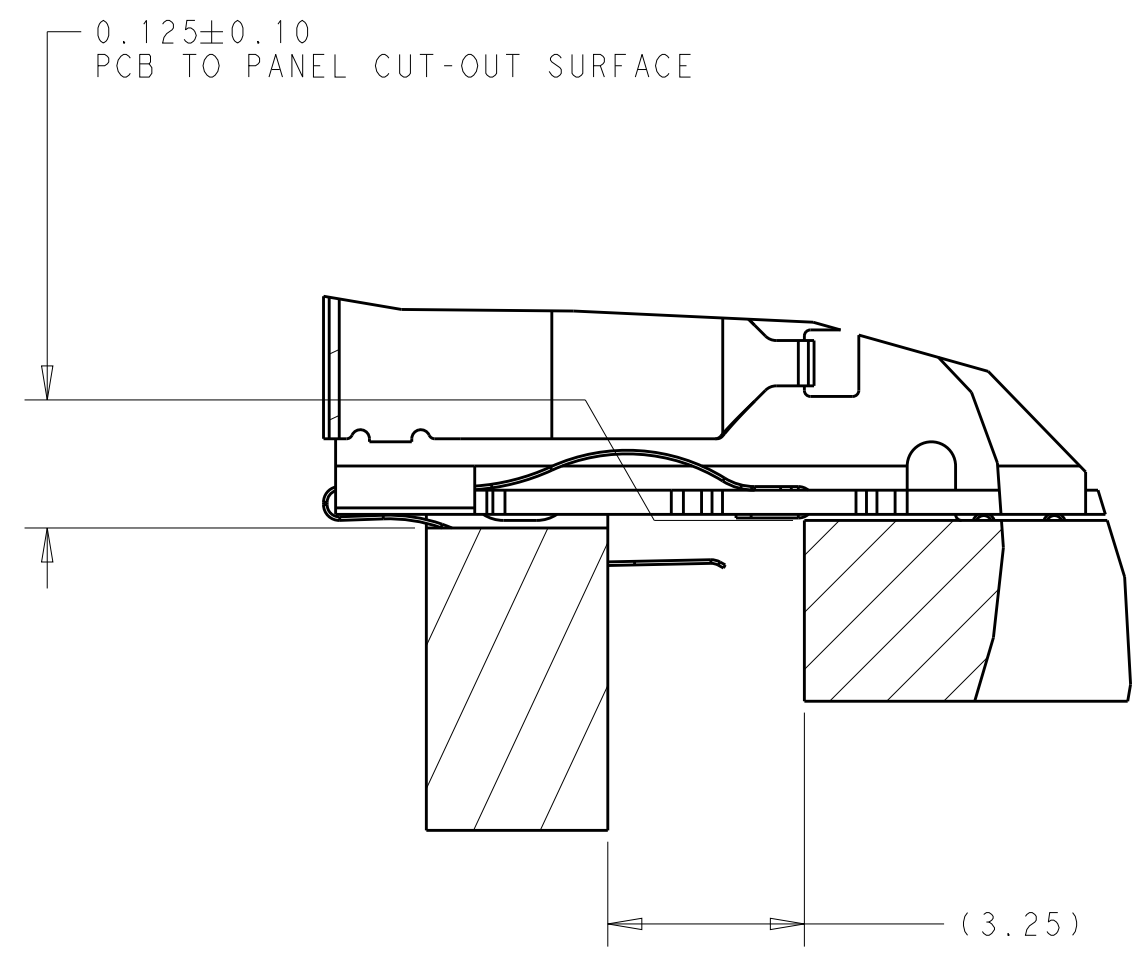
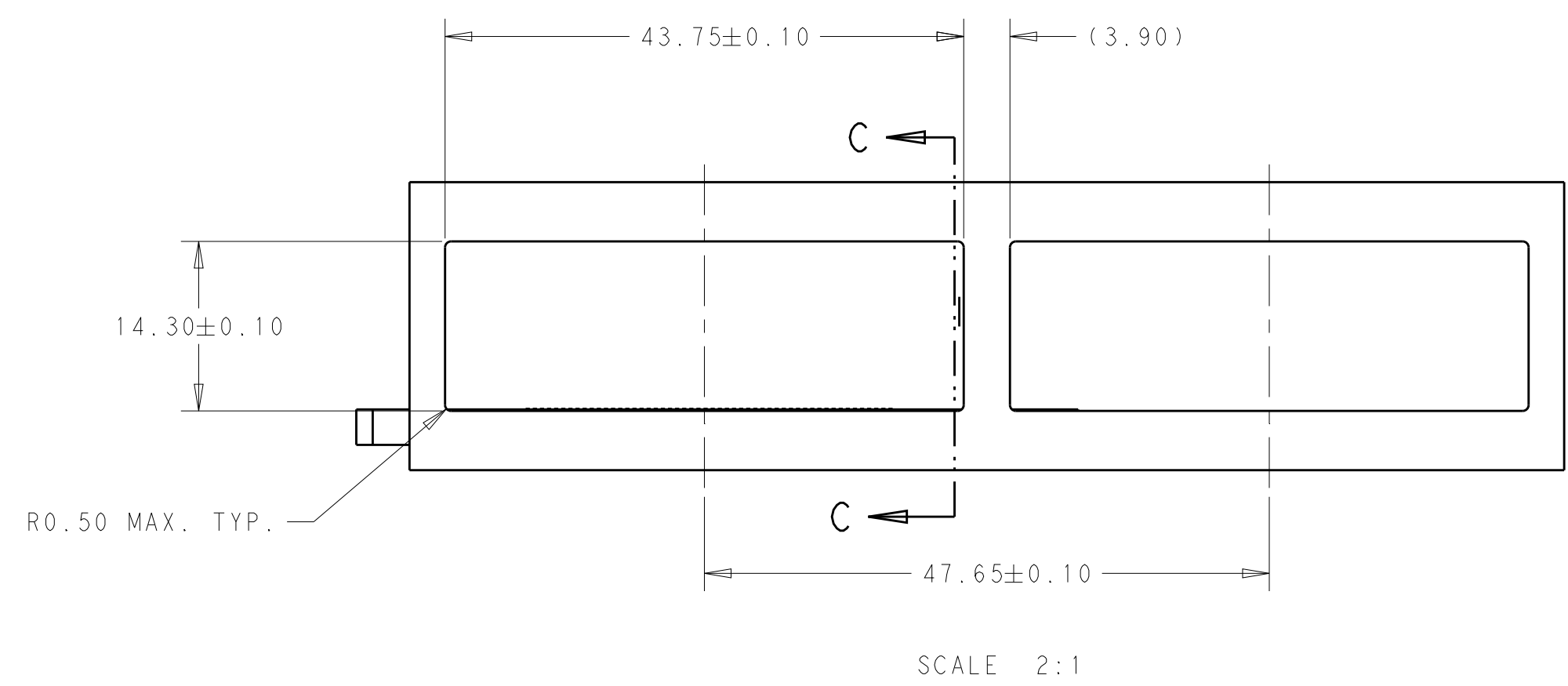

DETAIL B  
 SCALE 8:1

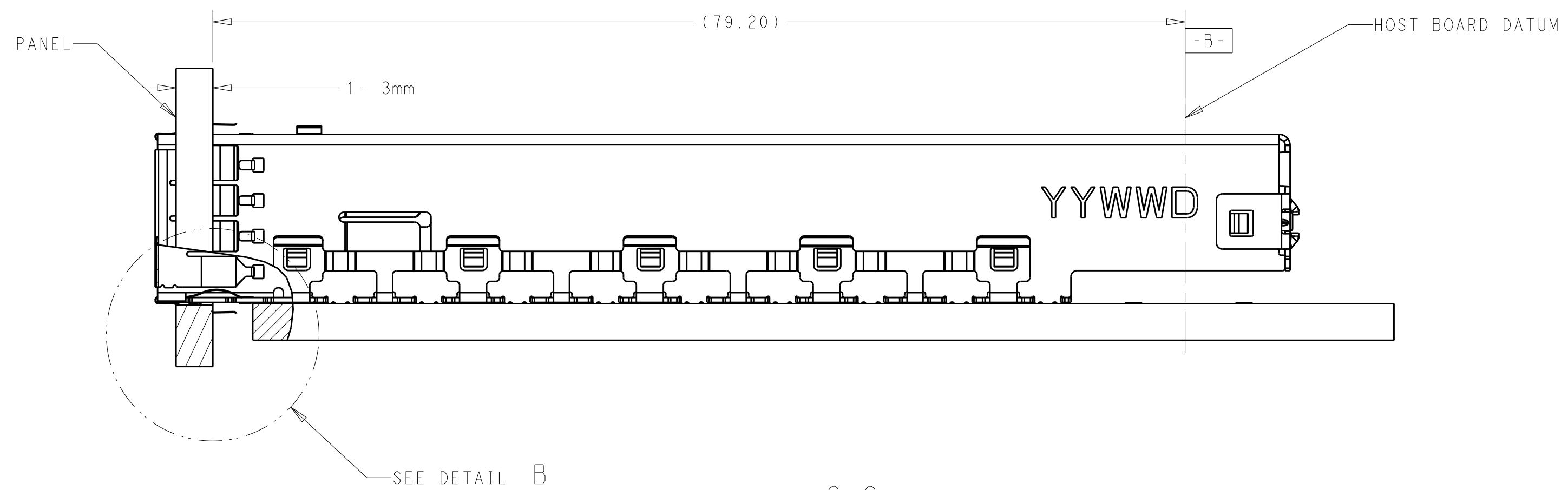

SECTION C-C  
 SCALE 3:1

THIS PRINT IS  
**PRELIMINARY**  
 UNQUALIFIED PRODUCT  
 CONTACT PRODUCT ENGINEERING  
 BEFORE USING THIS PRINT

THIS DRAWING IS A CONTROLLED DOCUMENT.		DWN ANDY.XIE 30MAY2016	TE Connectivity	
DIMENSIONS: mm		CHK SEAN.HAN 30MAY2016		
TOLERANCES UNLESS OTHERWISE SPECIFIED:		APVD SEAN.HAN 30MAY2016	NAME CAGE ASSEMBLY ,CFP2 1X1 PRESS FIT,EMI SPRING	
0 PLC ±		PRODUCT SPEC	SIZE A2	
1 PLC ±0.25		APPLICATION SPEC	CAGE CODE -	
2 PLC ±0.15		WEIGHT	DRAWING NO C-2274843	
3 PLC ±0.1		Customer Drawing	RESTRICTED TO -	
4 PLC ±		SCALE 1:1	SHEET 4 OF 4	
ANGLES ±1		REV 3		
FINISH				
MATERIAL SEE NOTES				
TOLERANCES UNLESS OTHERWISE SPECIFIED: SEE NOTES				

## X-ON Electronics

Largest Supplier of Electrical and Electronic Components

*Click to view similar products for [I/O Connectors](#) category:*

*Click to view products by [TE Connectivity](#) manufacturer:*

Other Similar products are found below :

[571763P](#) [72.250.1628.2](#) [72.250.2428.2](#) [74720-0505](#) [76.350.0729.0](#) [76871-1403](#) [FCN-244F080-G/1](#) [FCN-260A9920](#) [MP-5T180MUNNA-005](#)  
[PCR-E36PM](#) [PCS-XE26MA+](#) [G38A71314B](#) [1571250010](#) [157-22500-3](#) [MS3471L14-19P L/C](#) [91-569786-35H](#) [172501-4002](#) [172501-6002](#)  
[FCN-260C008-A/L0](#) [FCN-260C024-AL0](#) [FCN-261Z008](#) [2000314-1](#) [200331-1](#) [PCR-E36FC+](#) [PCS-E28FS+](#) [PCS-XE26SLFD+](#) [PCS-](#)  
[XE26SLFDT+](#) [G730VID08BDC24](#) [HDMR-29-01-S-SM-TR](#) [U90B2054081210](#) [UE86K842720321](#) [38113800006](#) [DP3AR020WQ1R200](#)  
[Z4.102.0680.0](#) [500-1040](#) [500-1052](#) [500-1054](#) [ZP-4008-66L](#) [0709821002](#) [10-565995-597N](#) [DX40-20P\(55\)](#) [5554841-1](#) [U90B3054061110](#)  
[U65-E04-4020](#) [ZPF00000000097891](#) [557-262M2-06C](#) [747360449](#) [10099439-003C-TRLF](#) [10137239-0021LF](#) [E9320-001-01](#)