

LOC	DIST	REVISIONS					
		P	LTN	DESCRIPTION	DATE	DWN	APVD
		A		INITIAL RELEASE	24MAR2017	AJ	SH
		B		REVISED PER ECO-18-005125	02APR2018	TX	SH
		C		REVISED PER ECR-21-000644	2FEB2021	RM	SZ

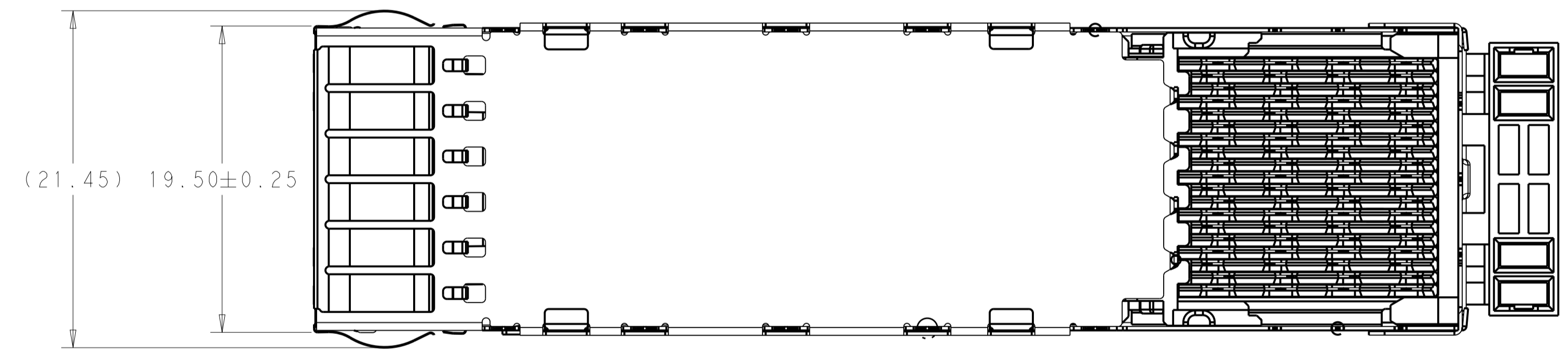
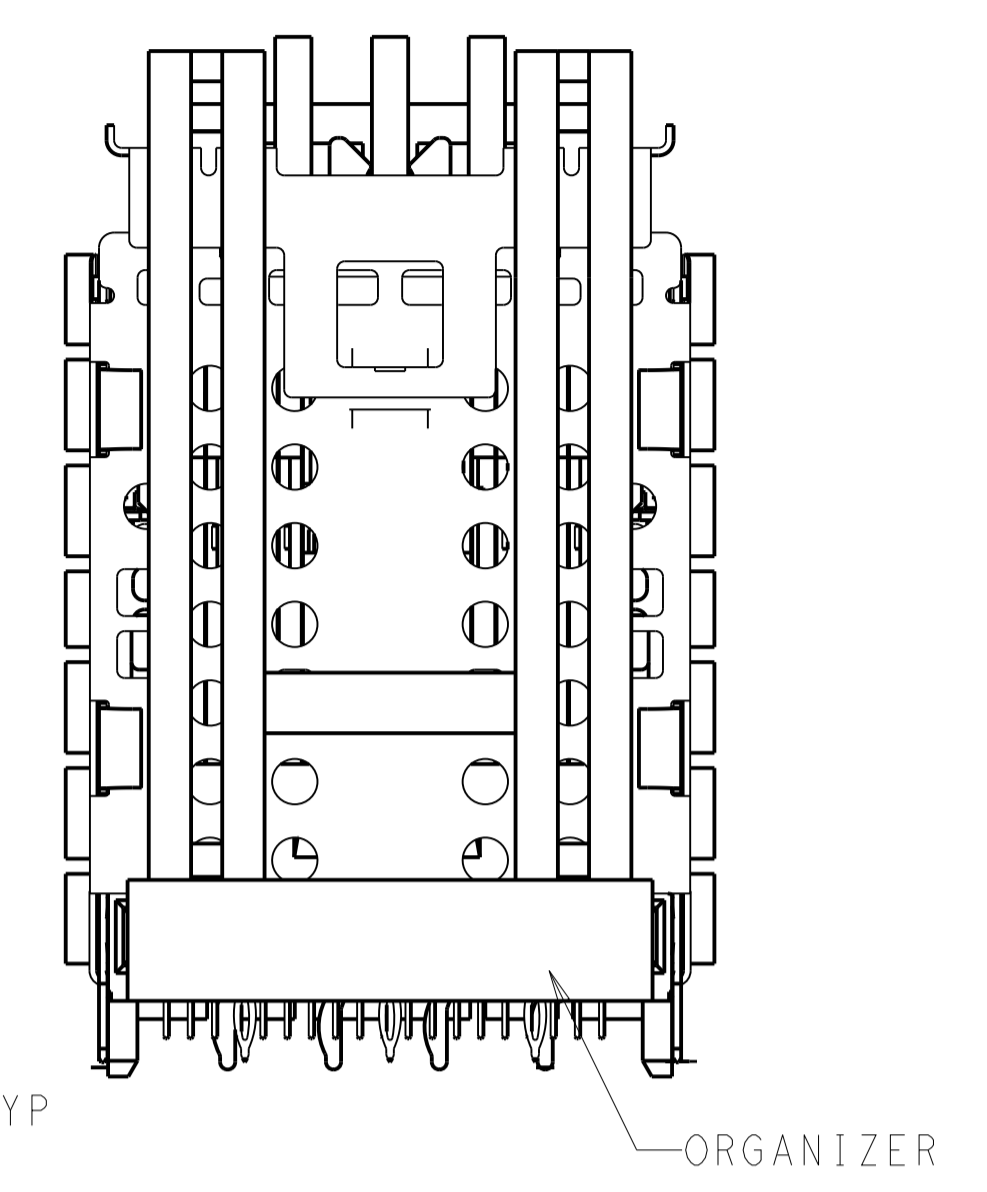
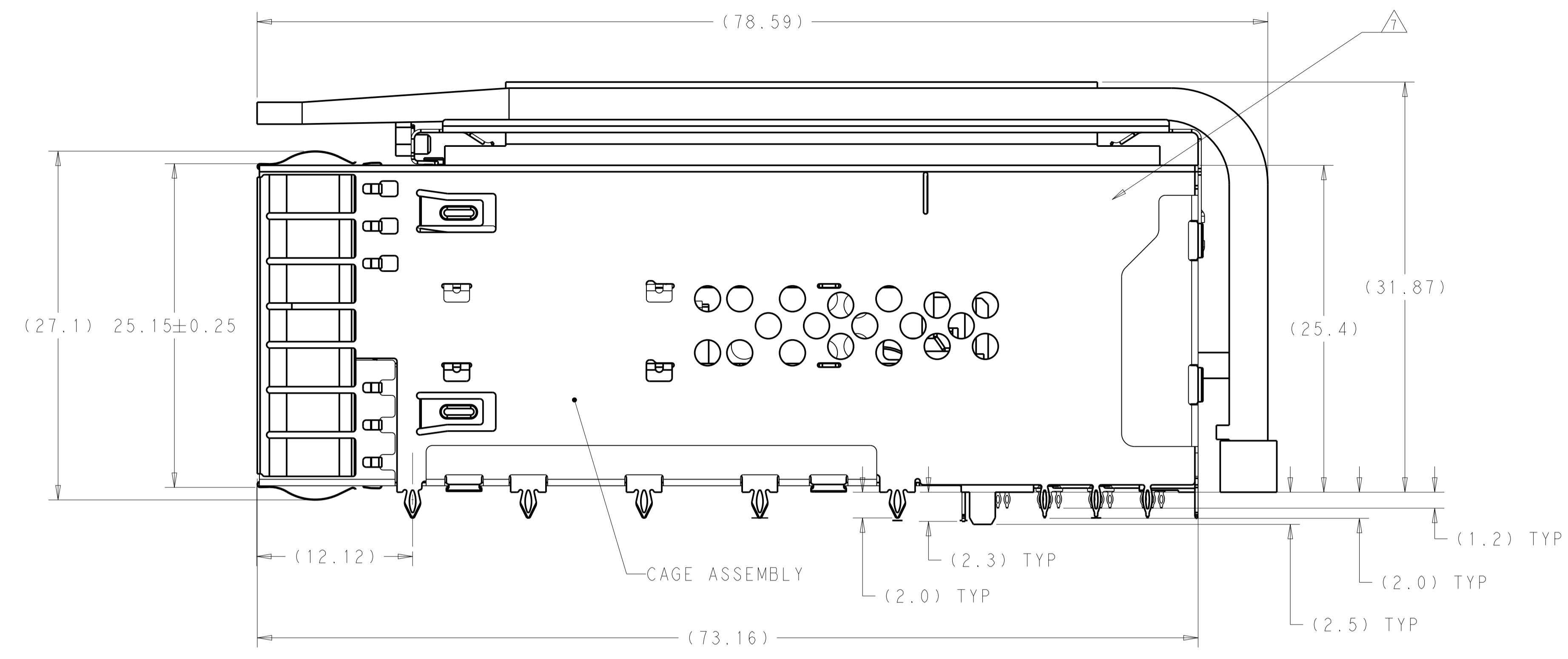
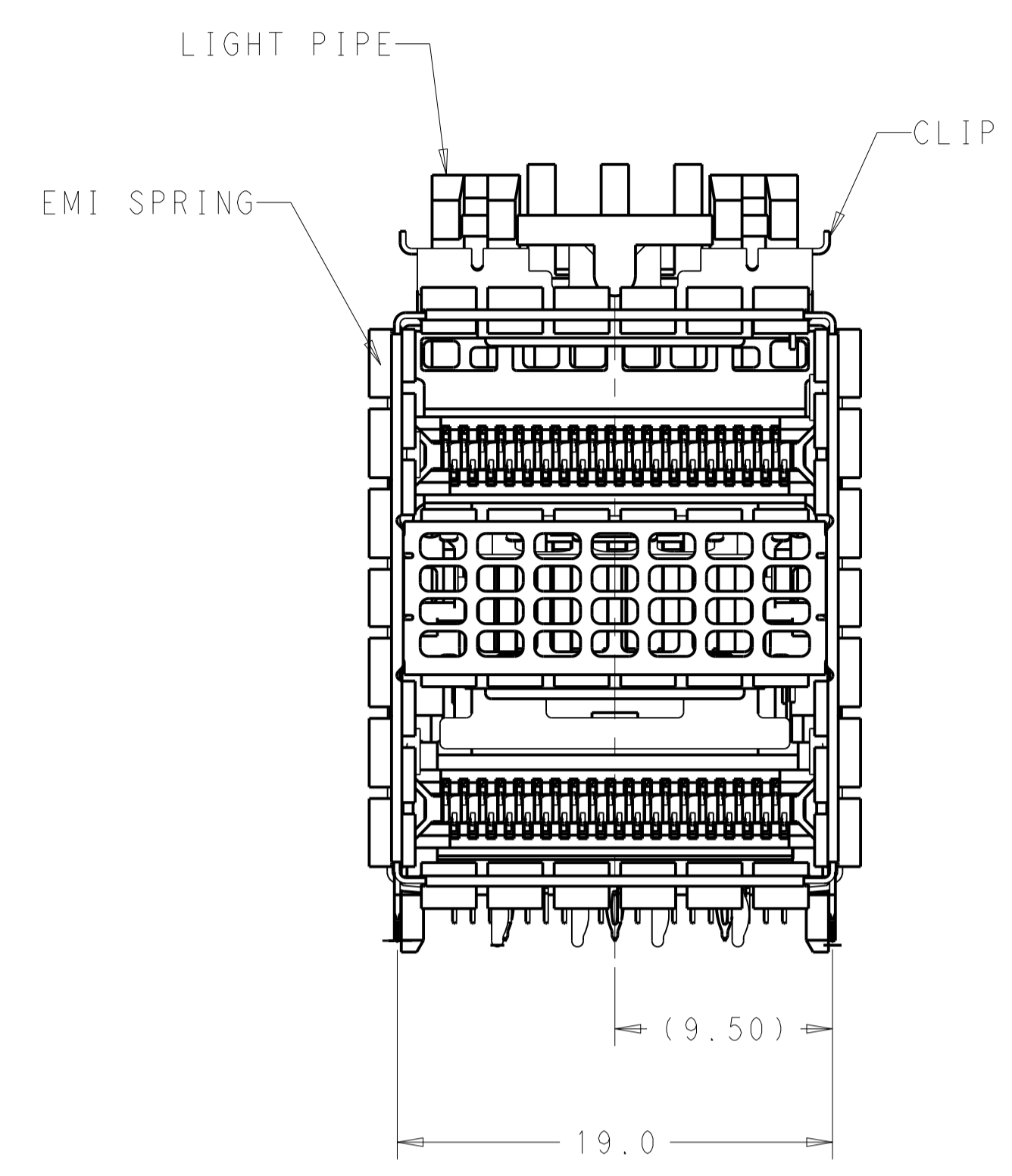

1. MATERIALS:
 CAGE ASSEMBLY- NICKEL SILVER ALLOY PER ASTM B 122.
 EMI SPRING- COPPER ALLOY, NICKEL PLATED.
 HOUSING- POLYESTER LCP WITH 94V-0.
 CHICKLET- POLYESTER LCP WITH 94V-0.
 CONTACT- COPPER ALLOY.
 LIGHTPIPE- POLYCARBONATE WITH 94V-0.

- △ CONTACT FINISH: 0.76µm GOLD ON MATING END, 1.25µm MATT TIN ON SOLDER TAIL, ALL OVER 1.27µm NICKEL.
- △ DATUM AND BASIC DIMENSION ESTABLISHED BY CUSTOMER.
- 4. MINIMUM PCB THICKNESS OF 1.57.
- △ THE ENTIRE AREA OF THE CONNECTOR FOOTPRINT, INDICATED BY THE DASHED LINE, TO BE CONSIDERED THE KEEPOUT AREA FOR COMPONENTS.
- △ CROSS-HATCHED AREAS REPRESENT ZONES ON THE PCB THAT COME IN CONTACT WITH OR BE IN CLOSE PROXIMITY TO THE PLASTIC HOUSING OR THE CONNECTOR CAGE. INDICATED AREAS TO BE CONSIDERED TRACE FREE.
- △ PART NUMBER AND DATE CODE MAKED IN APPROXIMATE AREA SHOWN.
- △ HATCHED AREA IS PLACEMENT ZONE FOR LED. LED SHOULD BE CENTERED WITHIN ZONE. RECOMMEND 0805 PACKAGE.

CONTACT FINISH	DESCRIPTION	PART NUMBER
△	WITH HS & WITH LP	1-2299940-2
△	WITH HS & WITH LP	2299940-8
△	WITH HS & WITHOUT LP	2299940-6
△	WITH HS & WITH LP	2299940-5
△	WITHOUT UPPER HS OR LP	2299940-4
△	WITH HS & WITHOUT LP	2299940-3
△	WITH HS & WITHOUT LP	2299940-2
△	WITH HS & WITH LP	2299940-1

THIS DRAWING IS A CONTROLLED DOCUMENT. DWN: ARTHUR JIN 02FEB2016
 CHK: SEAN HAN 02FEB2016
 APVD: SEAN HAN 02FEB2016

STE TE Connectivity

NAME: CAGE AND CONNECTOR ASSEMBLY WITH EMI SPRING FINGERS, THRU BEZEL, 2X1 ZOSFP+ STACKED WITH HS

SIZE: A1 CAGE CODE: 00779 DRAWING NO: 2299940 RESTRICTED TO: -

MATERIAL: SEE NOTE 1 FINISH: - WEIGHT: - CUSTOMER DRAWING

SCALE: 4:1 SHEET 1 OF 9 REV C

LOC		DIST		REVISIONS			
				REV	DATE	BY	APPV
-	-	-	-	-	-	-	-
-	-	-	-	-	SEE SHEET 1	-	-

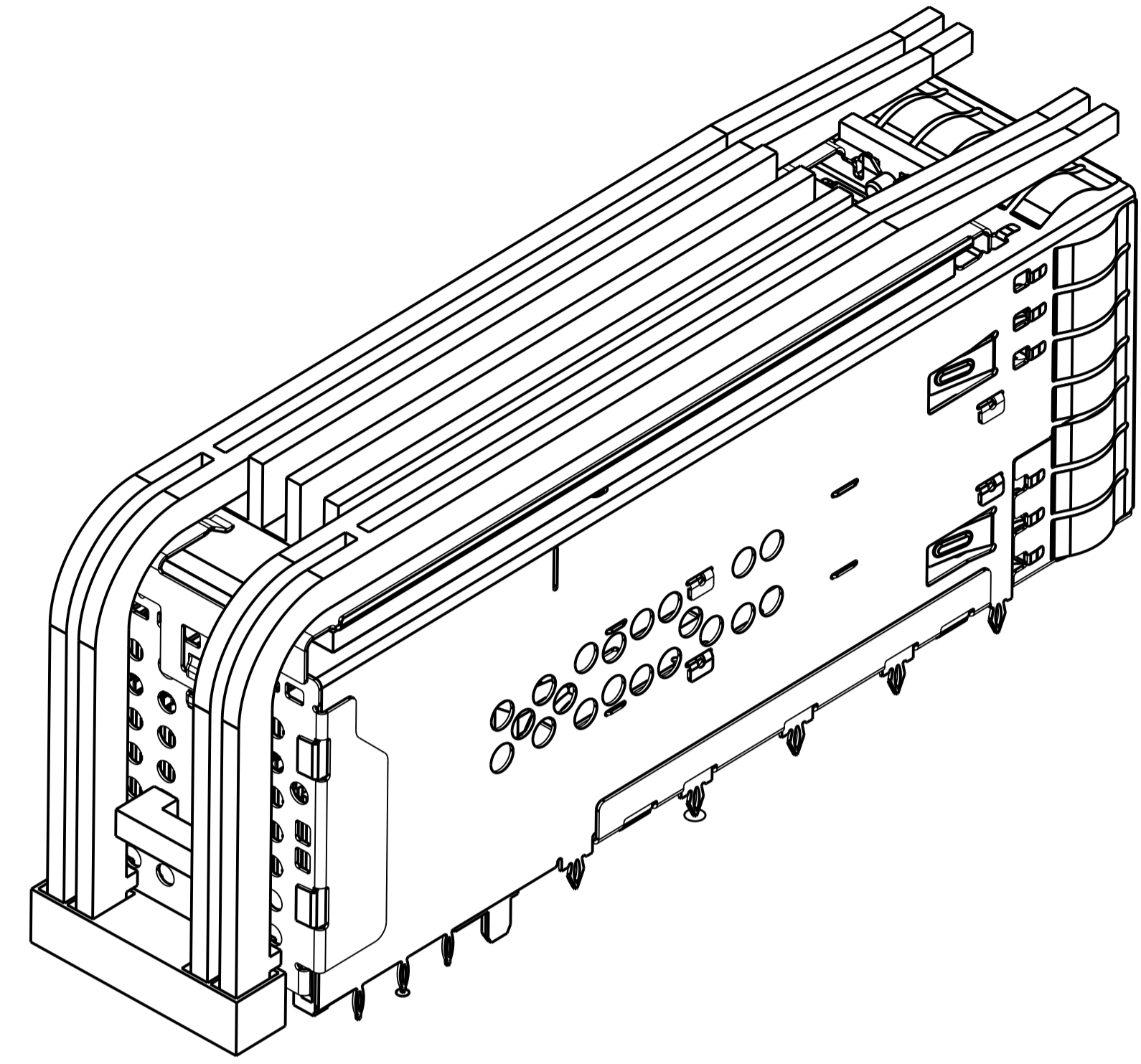

2299940-1 AS SHOWN
 SCALE 3:1

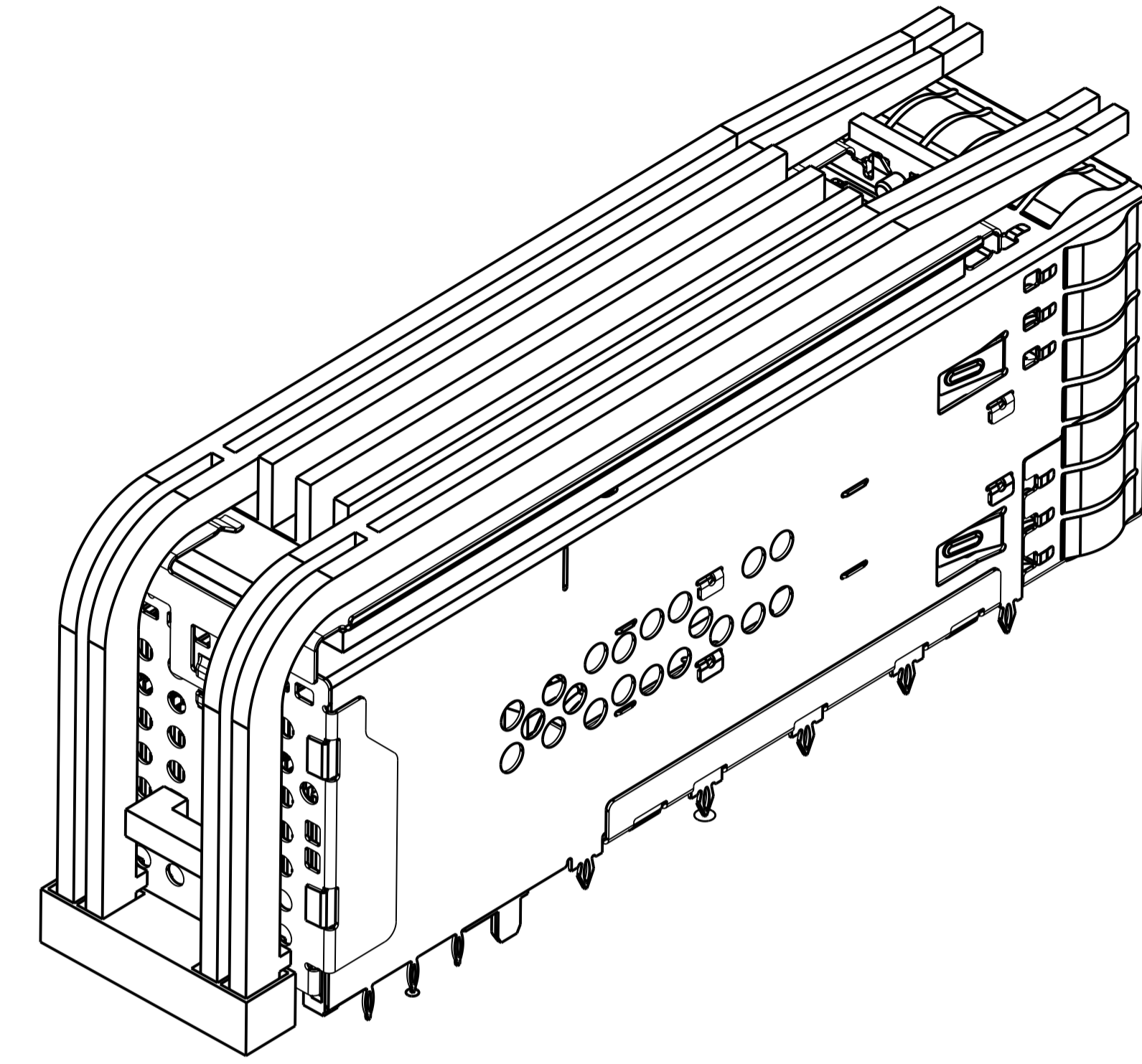

2299940-5 AS SHOWN
 THE SAME APPEARANCE WITH 2299940-1
 EXCEPT WITH DIFFERENT INTERNAL HEAT SINK
 SCALE 3:1

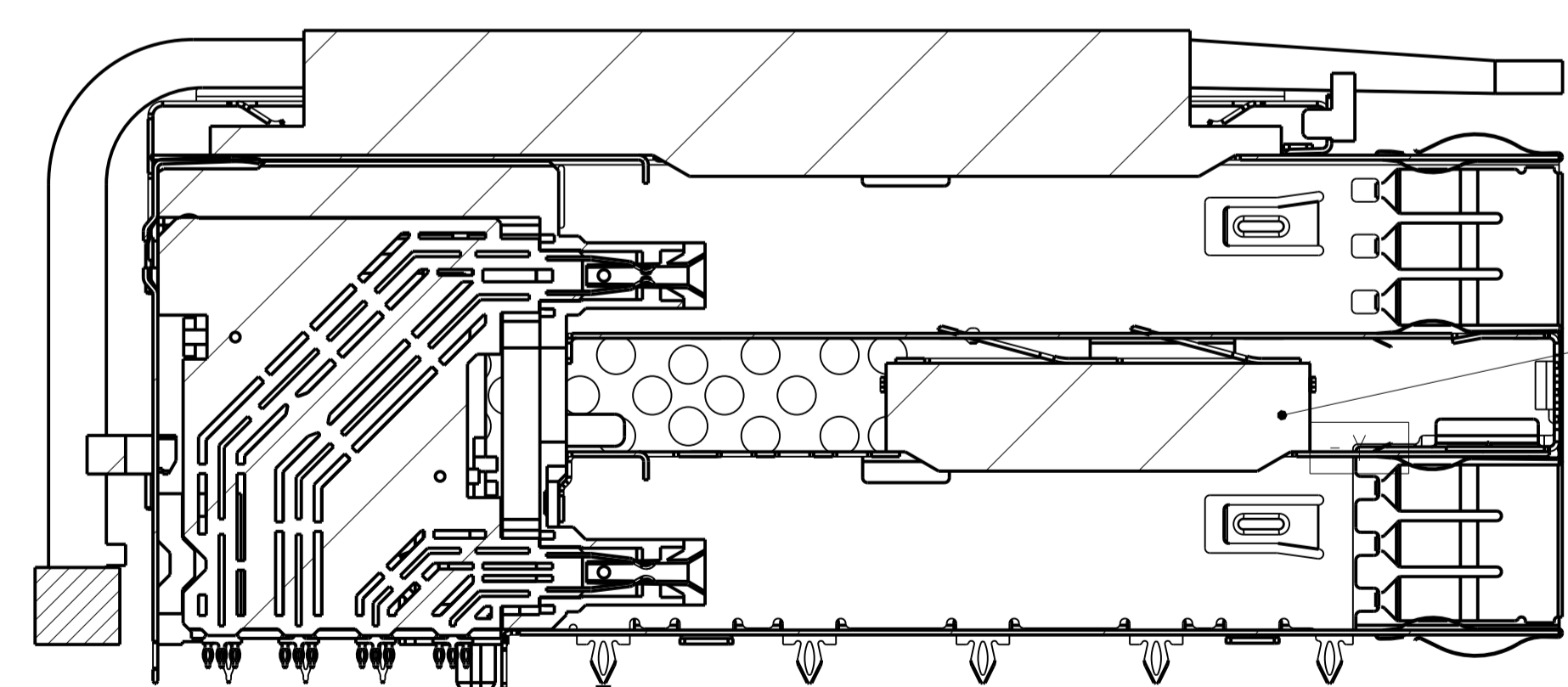

SHORT INTERNAL
 HEAT SINK

2299940-1/2299940-8 WITH SHORT INTERNAL HEAT SINK
 SECTION U-U
 SCALE 3:1

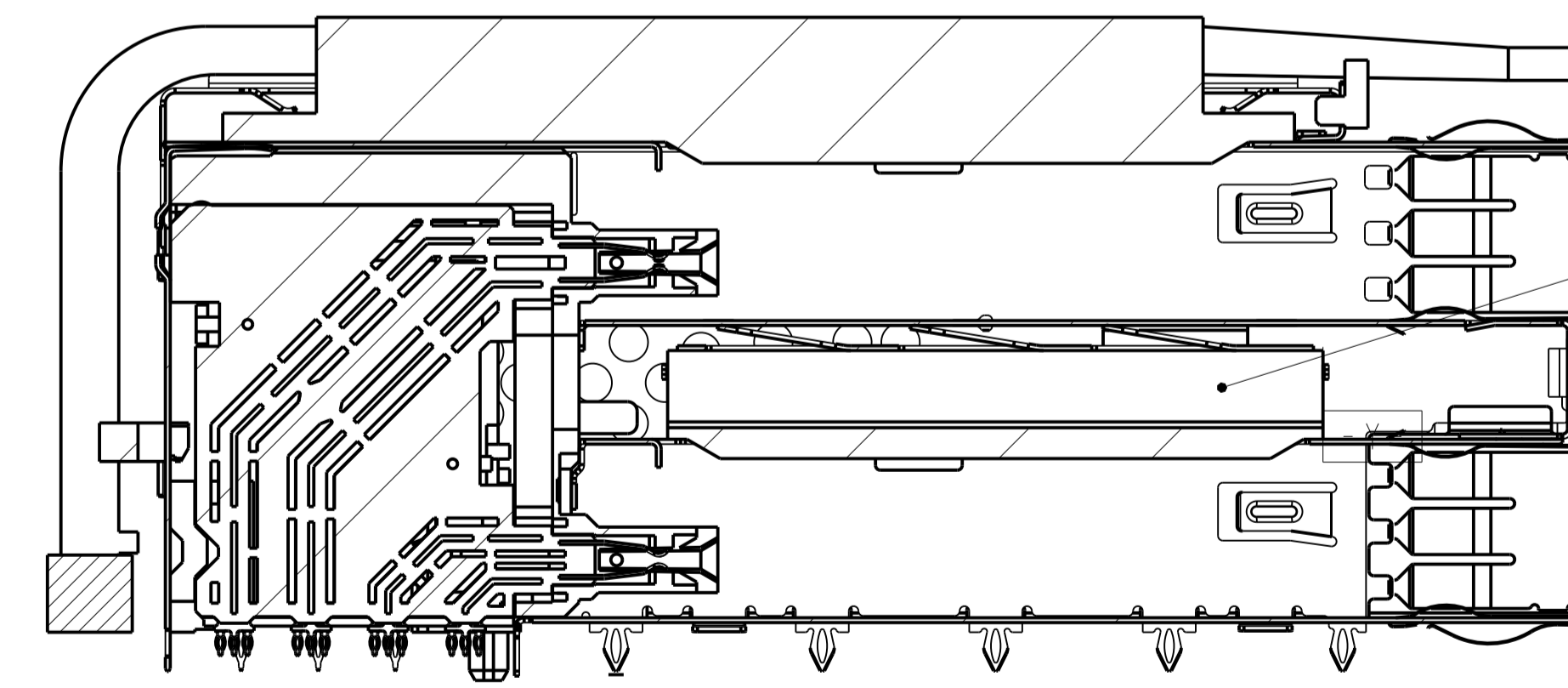

LONGER INTERNAL
 HEAT SINK

2299940-5 WITH LONGER INTERNAL HEAT SINK
 SECTION U-U
 SCALE 3:1

THIS DRAWING IS A CONTROLLED DOCUMENT.		OWN: ARTHUR JIN 02FEB2016	
DIMENSIONS: mm		CHK: SEAN HAN 02FEB2016	
TOLERANCES UNLESS OTHERWISE SPECIFIED:		APVD: SEAN HAN 02FEB2016	NAME: CAGE AND CONNECTOR ASSEMBLY WITH EMI SPRING FINGERS, THRU BEZEL, 2X1 ZQSF+ STACKED WITH HS
0 PLC ± 1 PLC ±0.25 2 PLC ±0.15 3 PLC ± 4 PLC ± ANGLES ±		PRODUCT SPEC	
MATERIAL: SEE NOTE 1		APPLICATION SPEC	RESTRICTED TO
		WEIGHT	SIZE: A1
		CUSTOMER DRAWING	CAGE CODE: 100779 DRAWING NO: C=2299940
		SCALE: 4:1	SHEET 2 OF 9
			REV C

LOC		DIST		REVISIONS			
				REV	DATE	BY	APPV
-	-	-	-	1	SEE SHEET 1	-	-

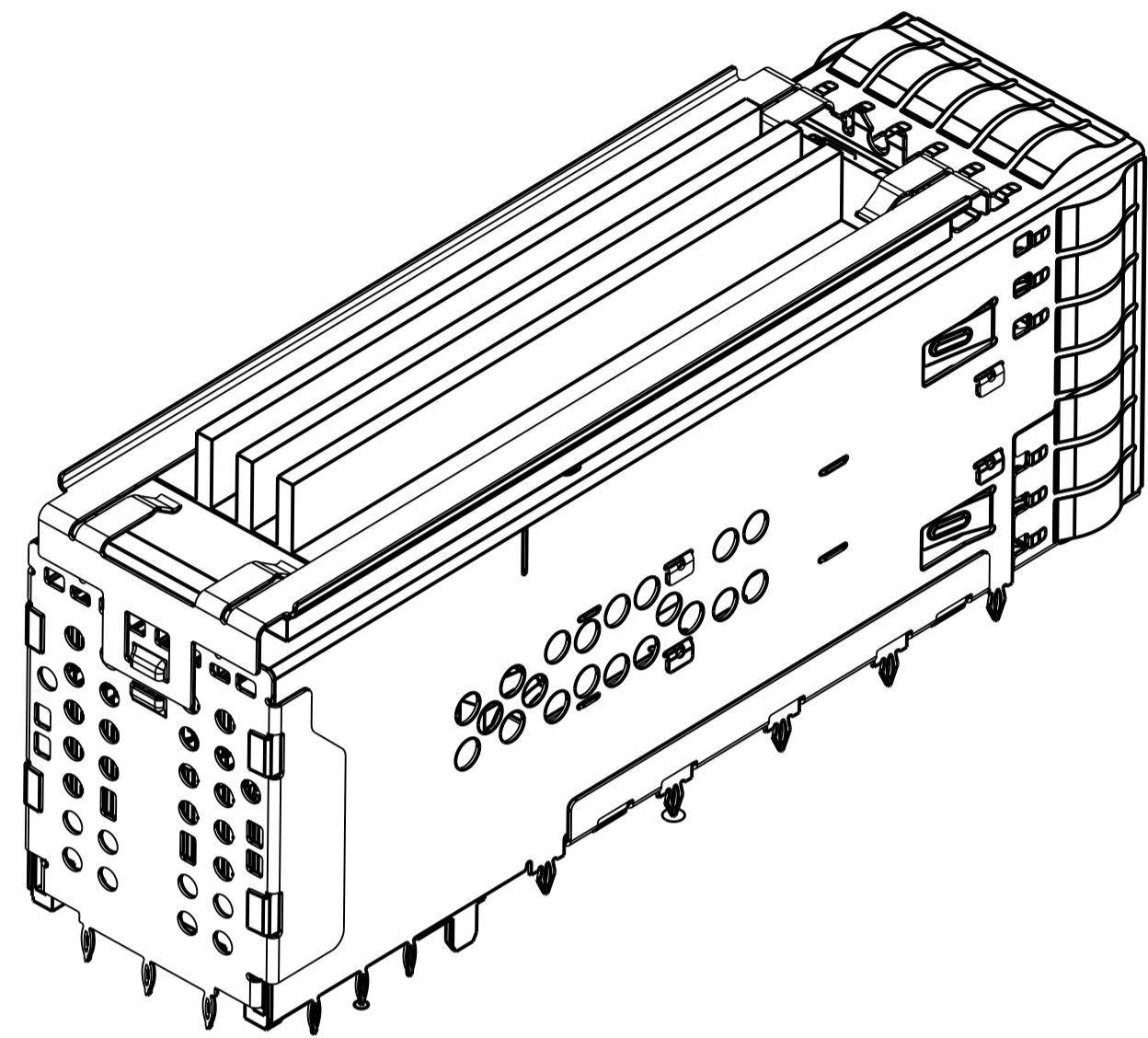

2299940-2 AS SHOWN
 THE SAME AS 2299940-5 EXCEPT
 W/O LIGHT PIPE AND ORGANIZER
 SCALE 5:2

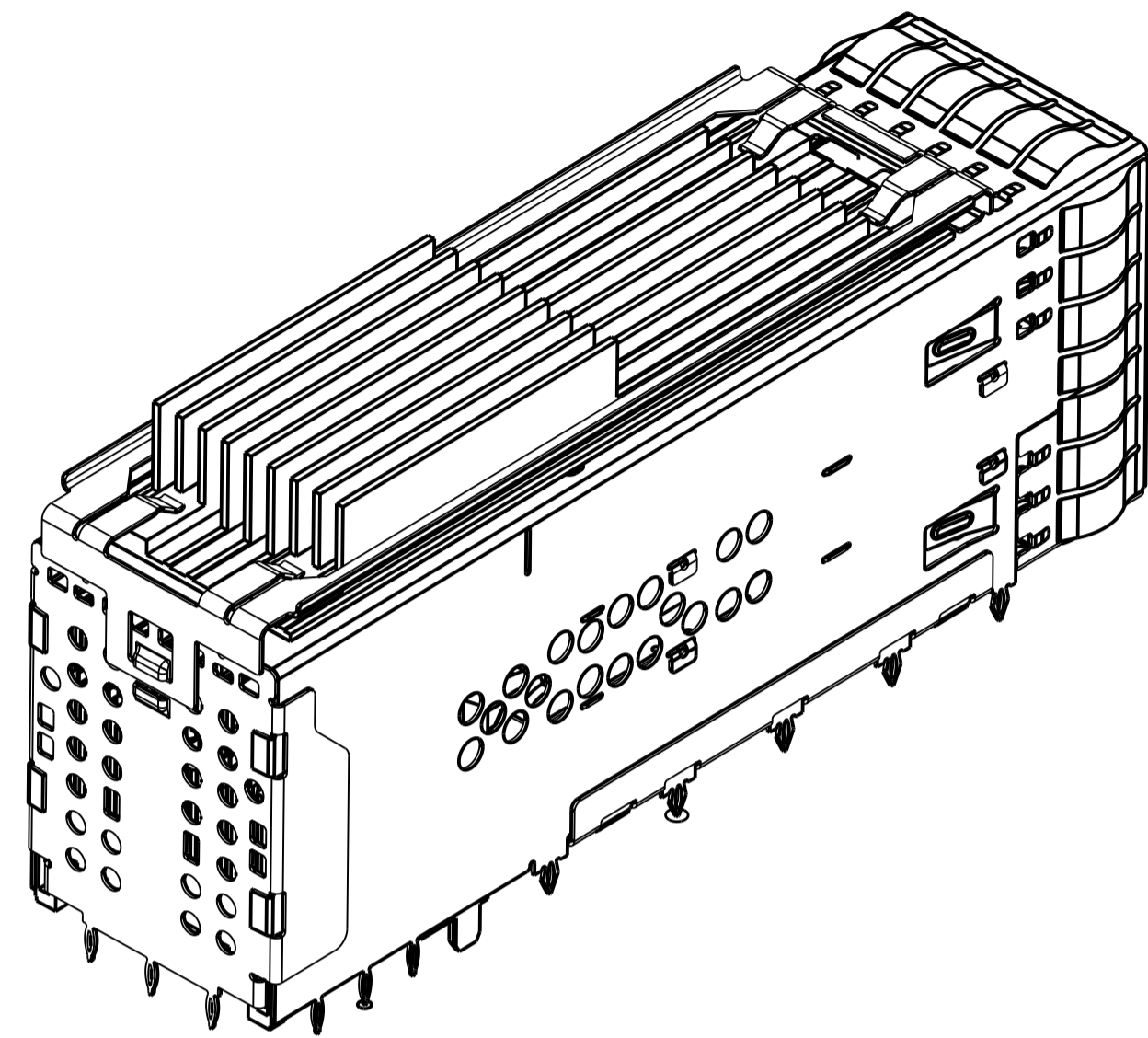

2299940-3 AS SHOWN
 THE SAME AS 2299940-2
 EXCEPT THE DIFFERENT EXTERNAL HEAT SINK
 SCALE 5:2

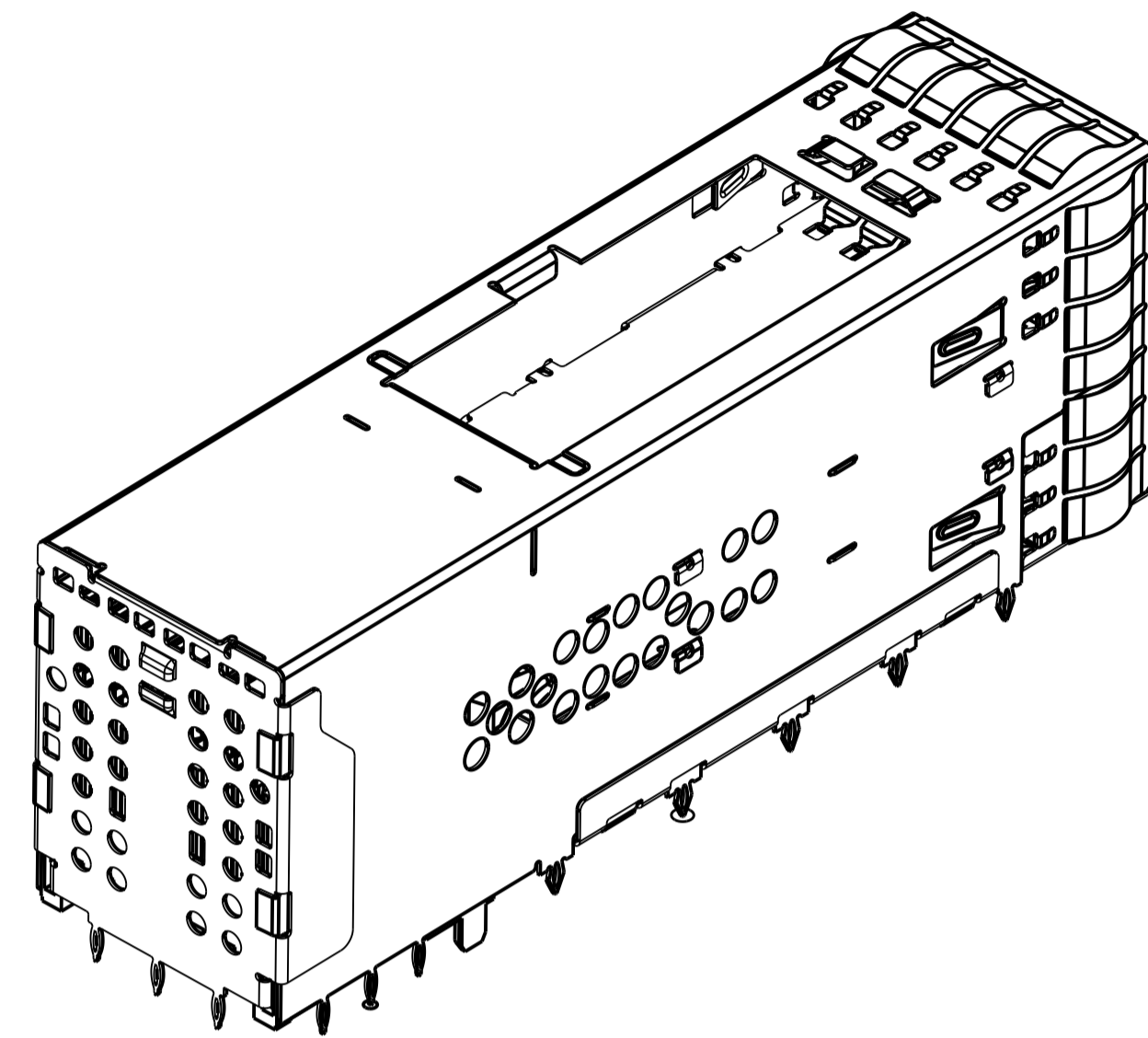

2299940-4 AS SHOWN
 THE SAME AS 2299940-2
 EXCEPT W/O EXTERNAL HEAT SIN/CLIP
 SCALE 5:2

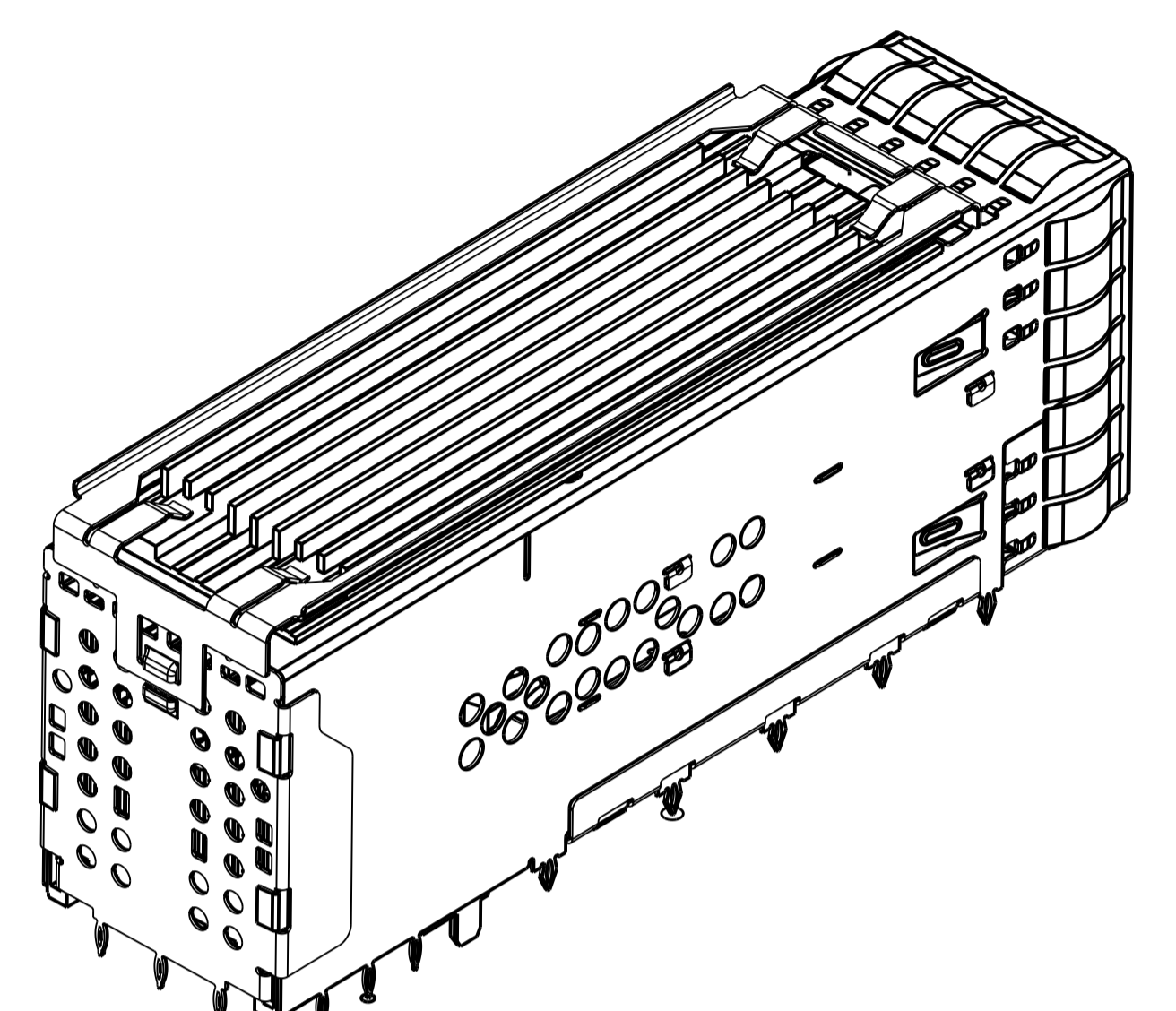

2299940-6
 THE SAME AS 2299940-2
 EXCEPT THE DIFFERENT EXTERNAL HEAT SINK
 SCALE 5:2

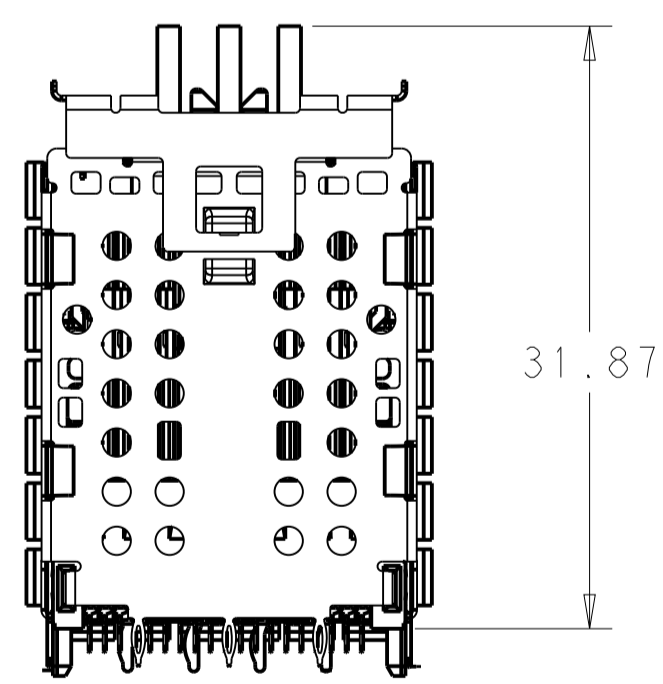

2299940-2 AS SHOWN
 SCALE 5:2

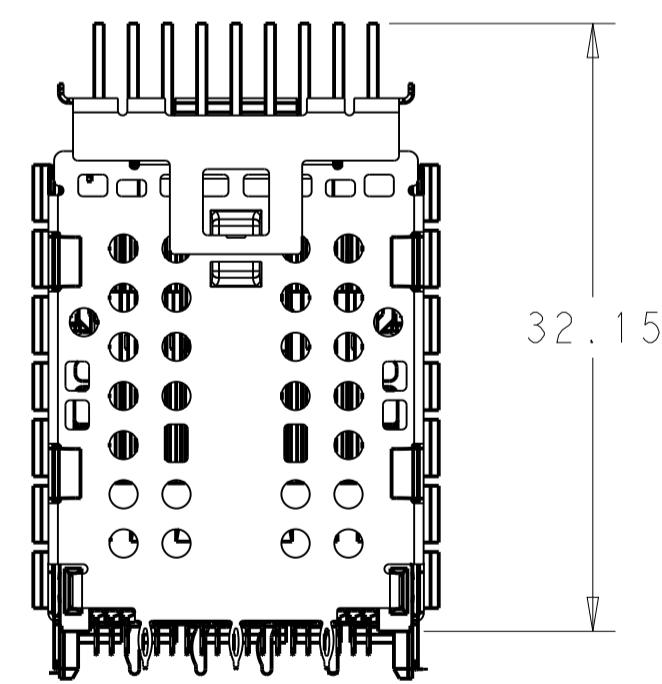

2299940-3 AS SHOWN
 SCALE 5:2

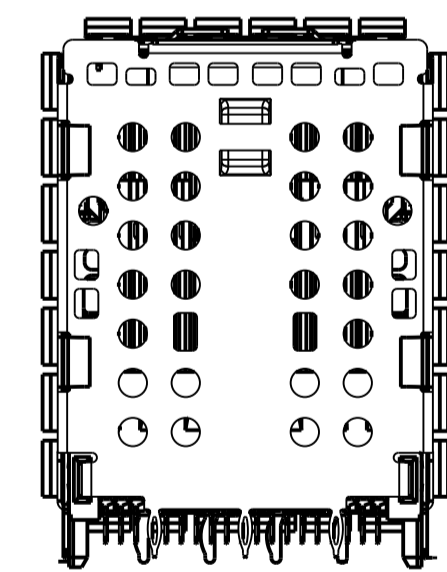

2299940-4 AS SHOWN
 SCALE 5:2

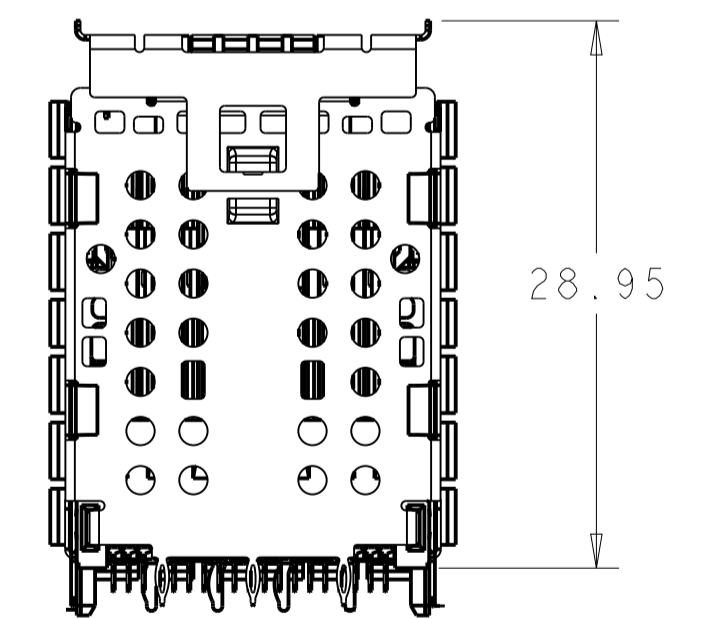

2299940-6 AS SHOWN
 SCALE 5:2

THIS DRAWING IS A CONTROLLED DOCUMENT.		OWN: ARTHUR JIN 02FEB2016	TE Connectivity
DIMENSIONS: mm		CHK: SEAN HAN 02FEB2016	
TOLERANCES UNLESS OTHERWISE SPECIFIED:		APVD: SEAN HAN 02FEB2016	NAME: CAGE AND CONNECTOR ASSEMBLY WITH EMI SPRING FINGERS, THRU BEZEL, 2X1 ZQSFP+ STACKED WITH HS
0 PLC ± 1 PLC ±0.25 2 PLC ±0.15 3 PLC ± 4 PLC ± ANGLES ±		PRODUCT SPEC: -	SIZE: A1
MATERIAL: SEE NOTE 1		APPLICATION SPEC: -	CAGE CODE: 100779
		WEIGHT: -	DRAWING NO: C=2299940
		CUSTOMER DRAWING	RESTRICTED TO: -
		SCALE: 4:1	SHEET 3 OF 9
			REV C

LOC		DIST		REVISIONS			
P	LTN	DESCRIPTION	DATE	DWN	APVD		
-	-	SEE SHEET 1	-	-	-		

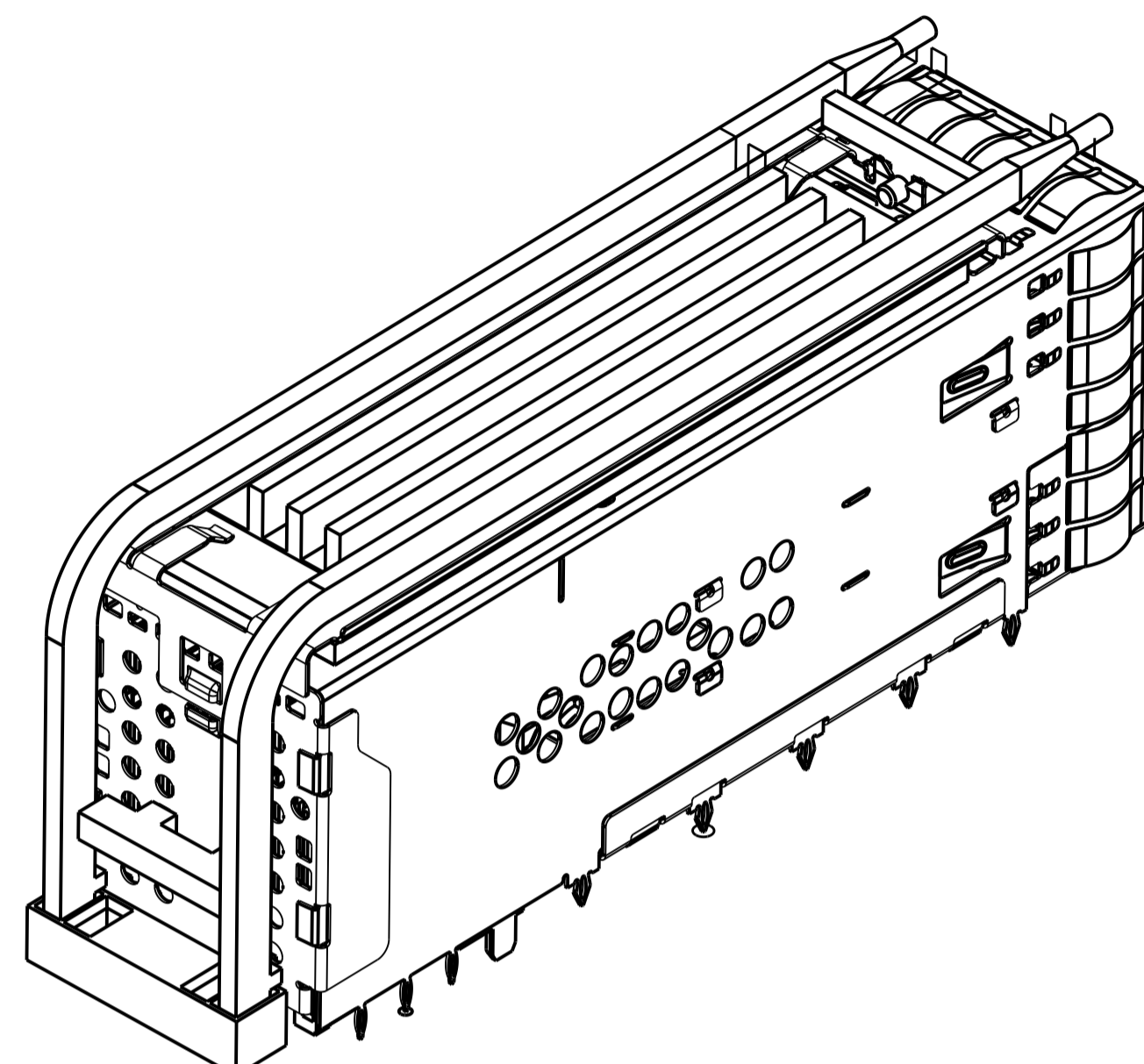

2299940-8 AS SHOWN
 THE SAME AS 2299940-1 EXCEPT
 LIGHT PIPE AND HS
 SCALE 5:2

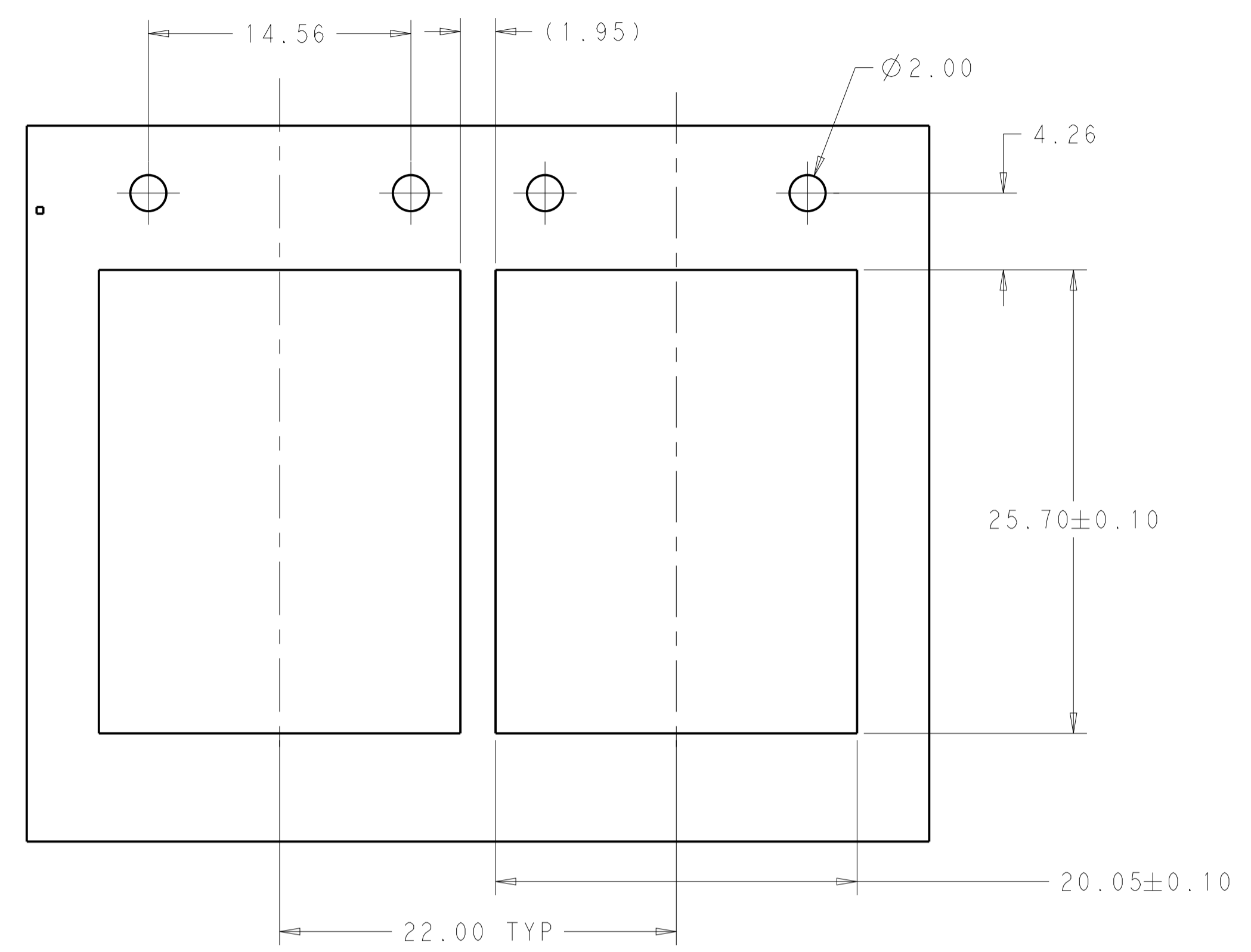

2299940-8 RECOMMENDED BEHIND BEZEL PANEL CUTOUT
 SCALE 4:1

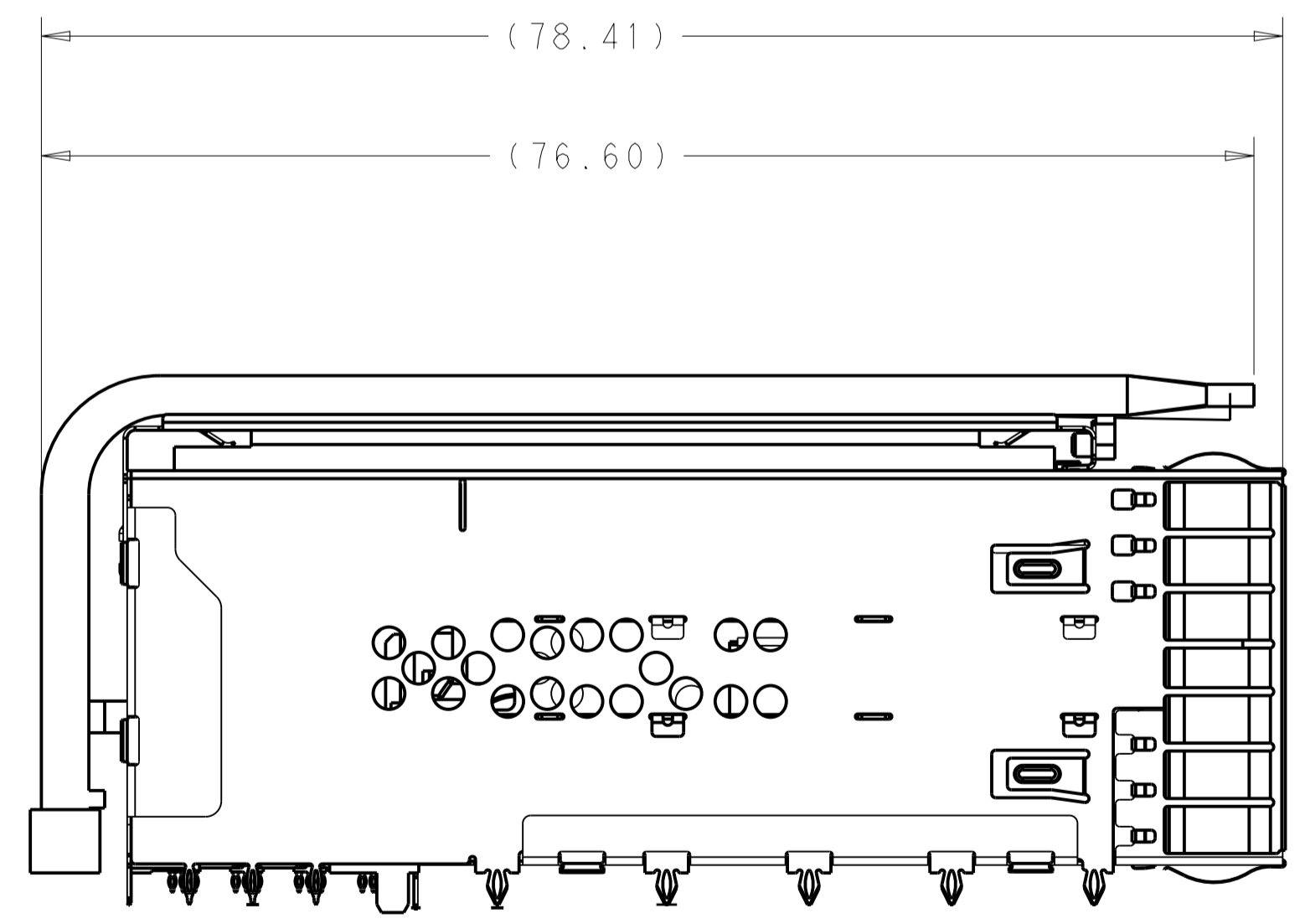
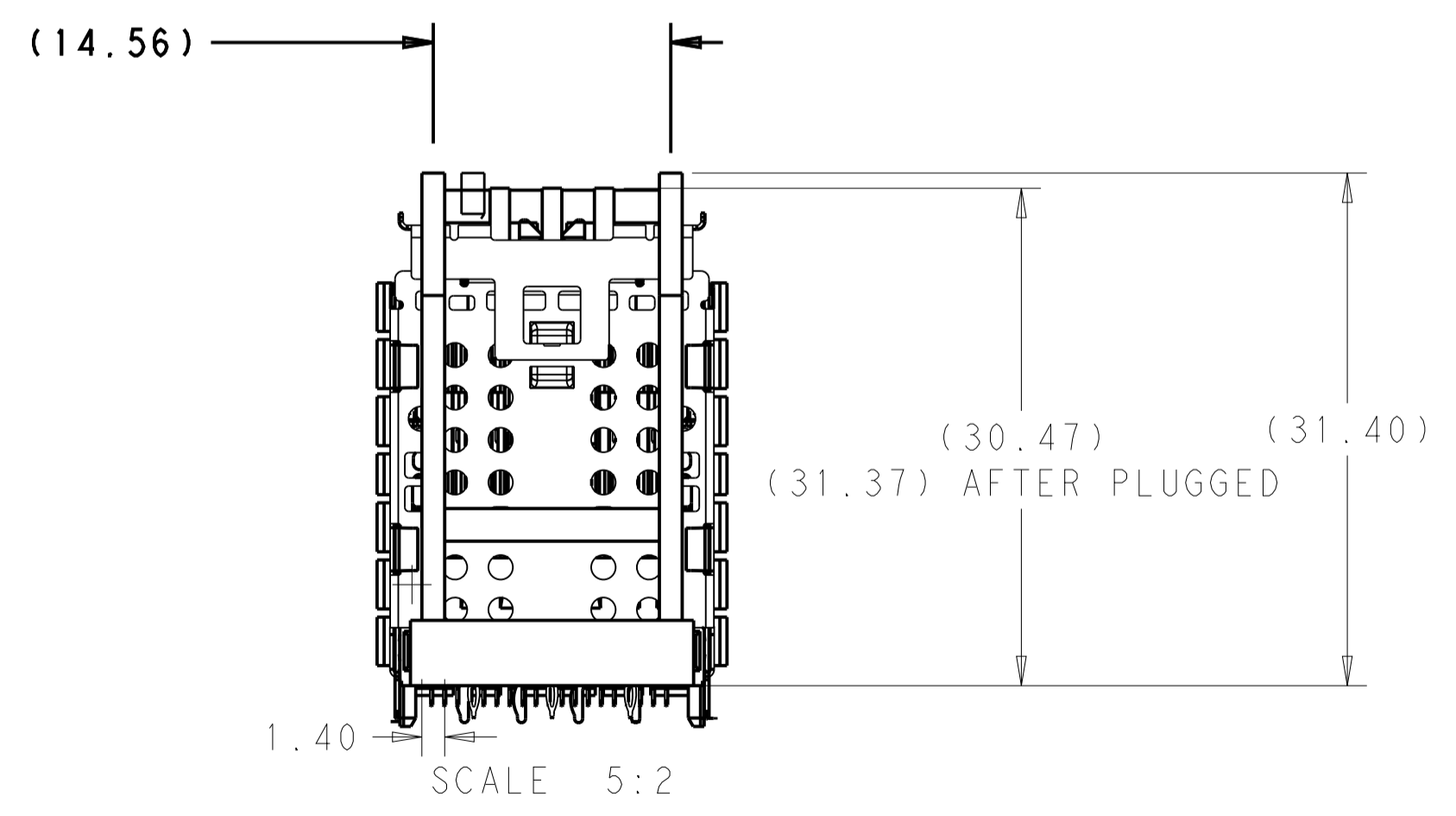

THIS DRAWING IS A CONTROLLED DOCUMENT.		DWN: ARTHUR JLN 02FEB2016	TE Connectivity
DIMENSIONS: mm		CHK: SEAN HAN 02FEB2016	
TOLERANCES UNLESS OTHERWISE SPECIFIED:		APVD: SEAN HAN 02FEB2016	NAME: CAGE AND CONNECTOR ASSEMBLY WITH EMI SPRING FINGERS, THRU BEZEL, 2X1 ZQSFP+ STACKED WITH HS
0 PLC ± 1 PLC ±0.25 2 PLC ±0.15 3 PLC ± 4 PLC ± ANGLES ±		PRODUCT SPEC	
MATERIAL: SEE NOTE 1		FINISH: -	APPLICATION SPEC
		WEIGHT: -	RESTRICTED TO
		CUSTOMER DRAWING	SIZE: A1 CAGE CODE: 100779 DRAWING NO: C=2299940
		SCALE: 4:1	SHEET 4 OF 9 REV C

LOC		DIST		REVISIONS			
P	LTN	DESCRIPTION	DATE	DMN	APVD		
-	-	SEE SHEET 1	-	-	-		

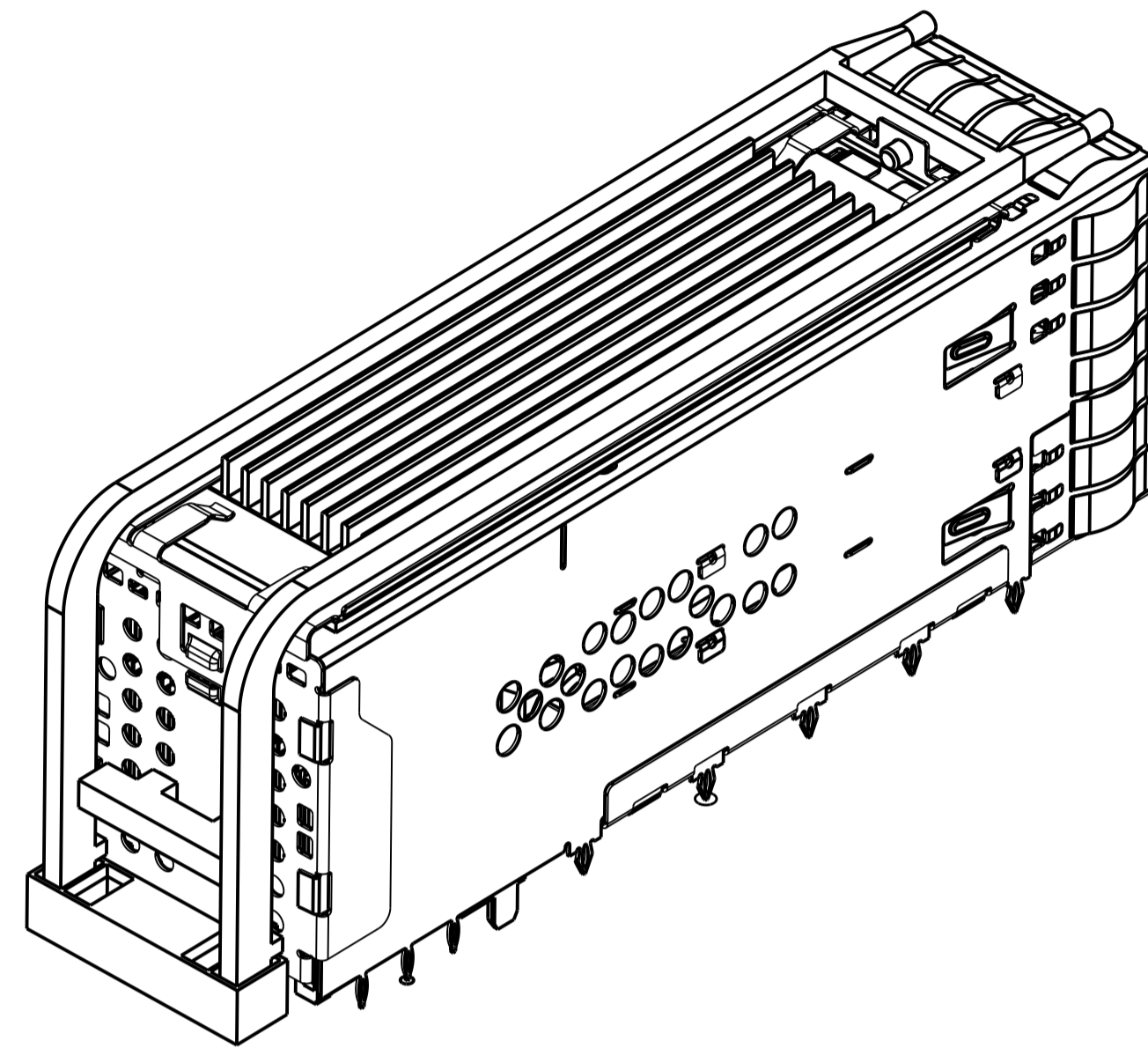

1-2299940-2 AS SHOWN
 THE SAME AS 2299940-5
 EXCEPT EXTERNAL HEAT SINK,
 HEAT SINK CLIP AND LIGHT PIPE
 SCALE 5:2

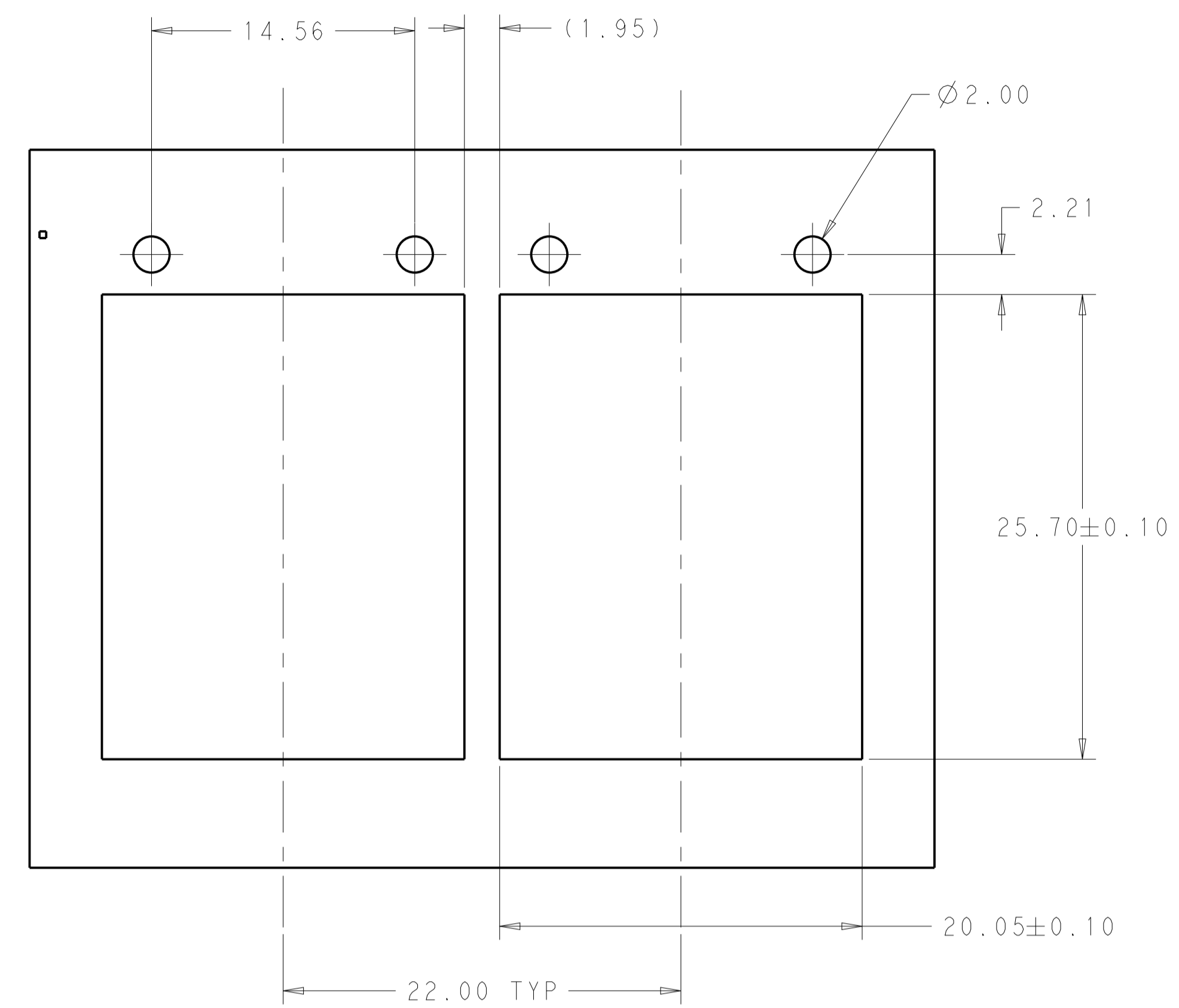

1-2299940-2 RECOMMENDED BEHIND BEZEL PANEL CUTOUT
 SCALE 4:1

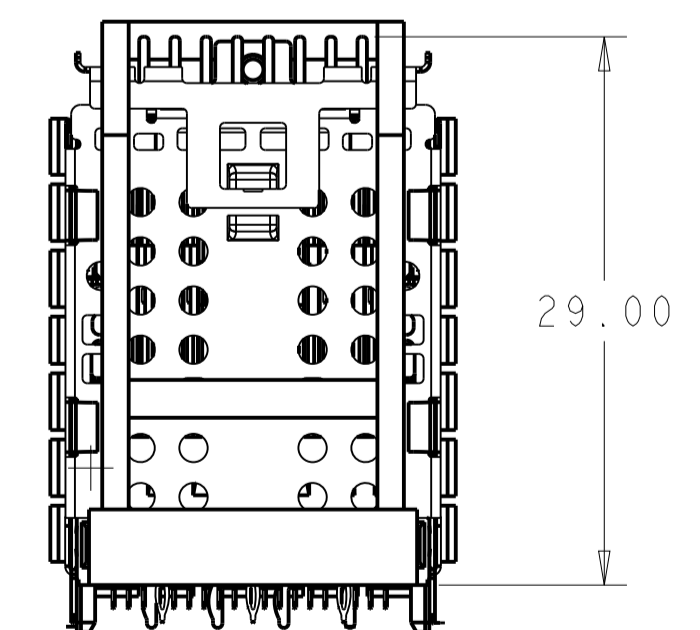

SCALE 5:2

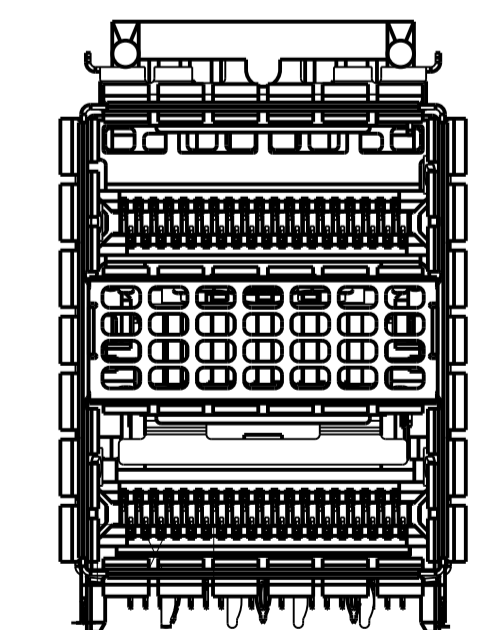
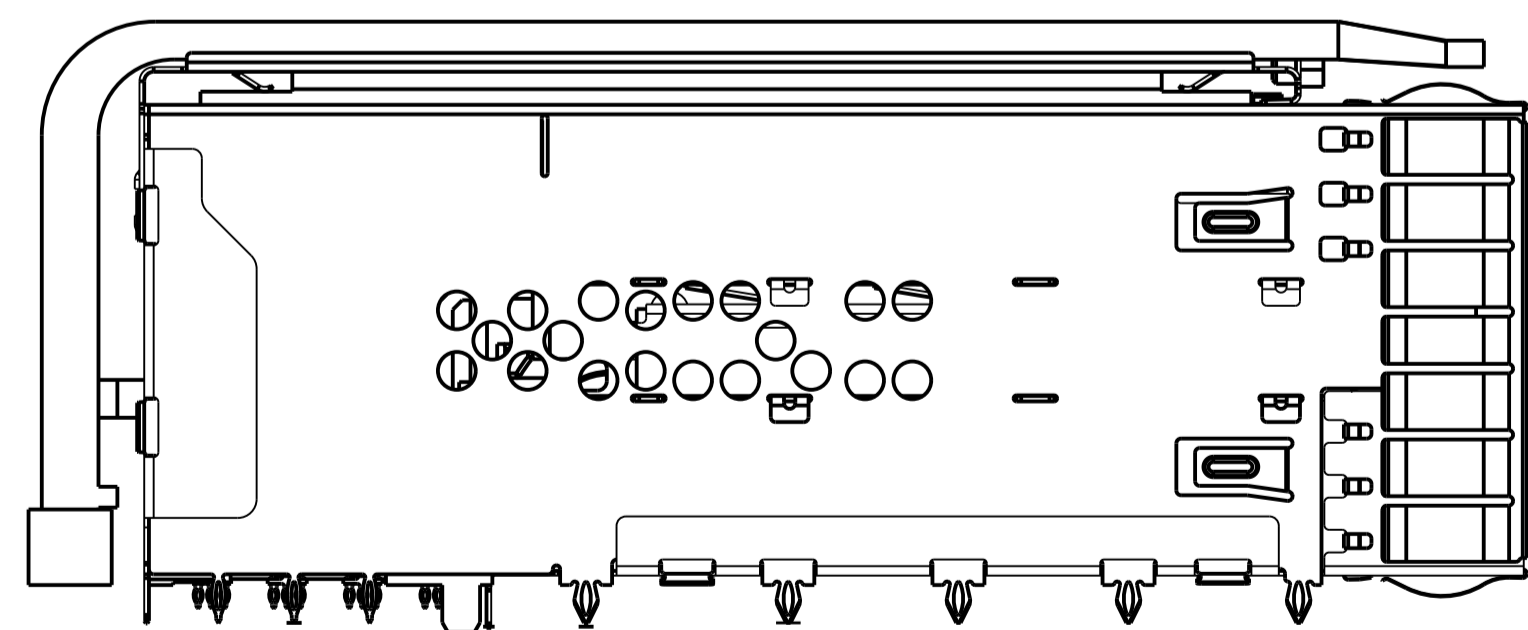

THIS DRAWING IS A CONTROLLED DOCUMENT.		DMN: ARTHUR_JLN 02FEB2016	TE Connectivity
DIMENSIONS: mm		CHK: SEAN_HAN 02FEB2016	
TOLERANCES UNLESS OTHERWISE SPECIFIED:		APVD: SEAN_HAN 02FEB2016	NAME: CAGE AND CONNECTOR ASSEMBLY WITH EMI SPRING FINGERS, THRU BEZEL, 2X1 ZGSFP+ STACKED WITH HS
0 PLC ± 1 PLC ±0.25 2 PLC ±0.15 3 PLC ± 4 PLC ± ANGLES ±		PRODUCT SPEC	
MATERIAL: SEE NOTE 1		FINISH: -	APPLICATION SPEC
		WEIGHT: -	RESTRICTED TO
		CUSTOMER DRAWING	SIZE: A1 CAGE CODE: 100779 DRAWING NO: C=2299940
		SCALE: 4:1	SHEET 5 OF 9 REV C

LOC		DIST		REVISIONS			
				REV	DATE	BY	APPD
-	-	-	-	1	SEE SHEET 1	-	-

2299940-3 AS SHOWN, KIT PACKAGE

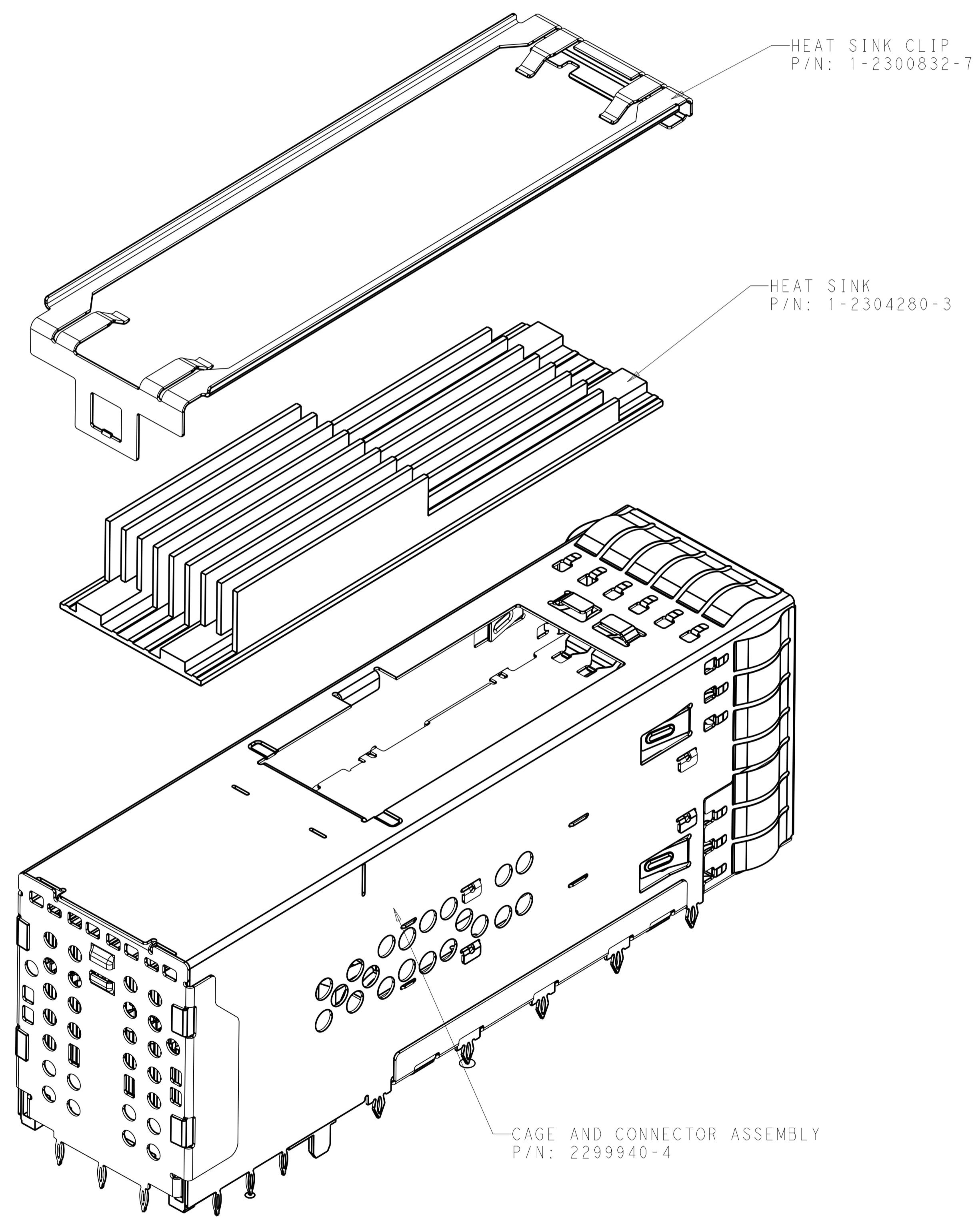

SCALE 4:1

2299940-6 AS SHOWN, KIT PACKAGE

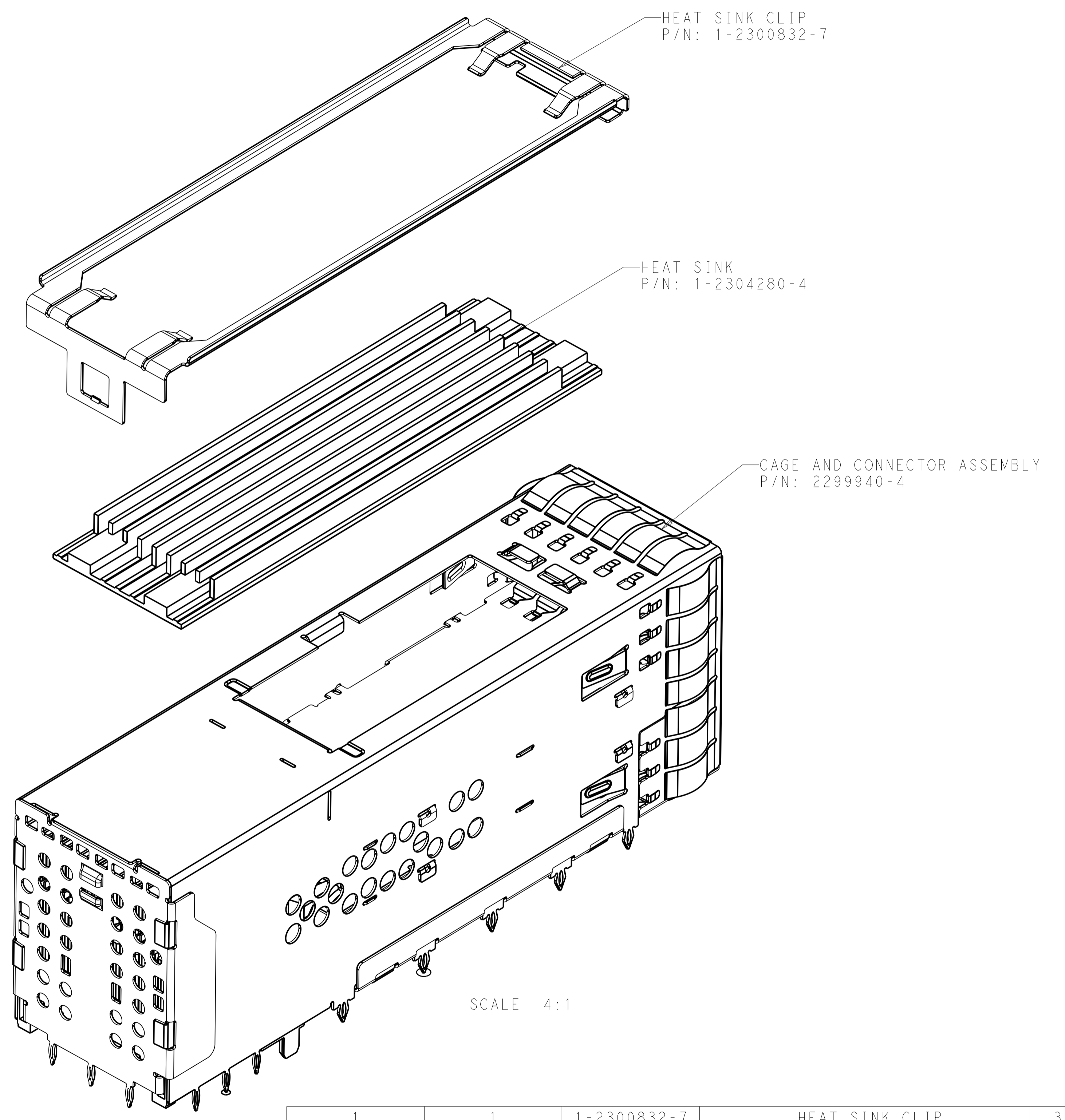

SCALE 4:1

1	1	1-2300832-7	HEAT SINK CLIP	3
1	-	1-2304280-4	HEAT SINK	2
-	1	1-2304280-3		
1	1	2299940-4	CAGE AND CONNECTOR ASSEMBLY	1
2299940-6	2299940-3	PART NUMBER	DESCRIPTION	ITEM

THIS DRAWING IS A CONTROLLED DOCUMENT.		OWN: ARTHUR JIN 02FEB2016	TE Connectivity
DIMENSIONS: mm		CHK: SEAN HAN 02FEB2016	
TOLERANCES UNLESS OTHERWISE SPECIFIED:		APPD: SEAN HAN 02FEB2016	
0 PLC ± 1 PLC ±0.25 2 PLC ±0.15 3 PLC ± 4 PLC ± ANGLES ±		NAME: CAGE AND CONNECTOR ASSEMBLY WITH EMI SPRING FINGERS, THRU BEZEL, 2X1 ZOSFP+ STACKED WITH HS	
MATERIAL: SEE NOTE 1	FINISH: -	WEIGHT: -	RESTRICTED TO: -
CUSTOMER DRAWING		SIZE: A1	SCALE: 4:1
		CAGE CODE: 00779	DRAWING NO: 2299940
		SHEET: 6	OF: 9
		REV: C	

LOC		DIST		REVISIONS			
				DESCRIPTION	DATE	OWN	APVD
-	-	-	-	SEE SHEET 1	-	-	-

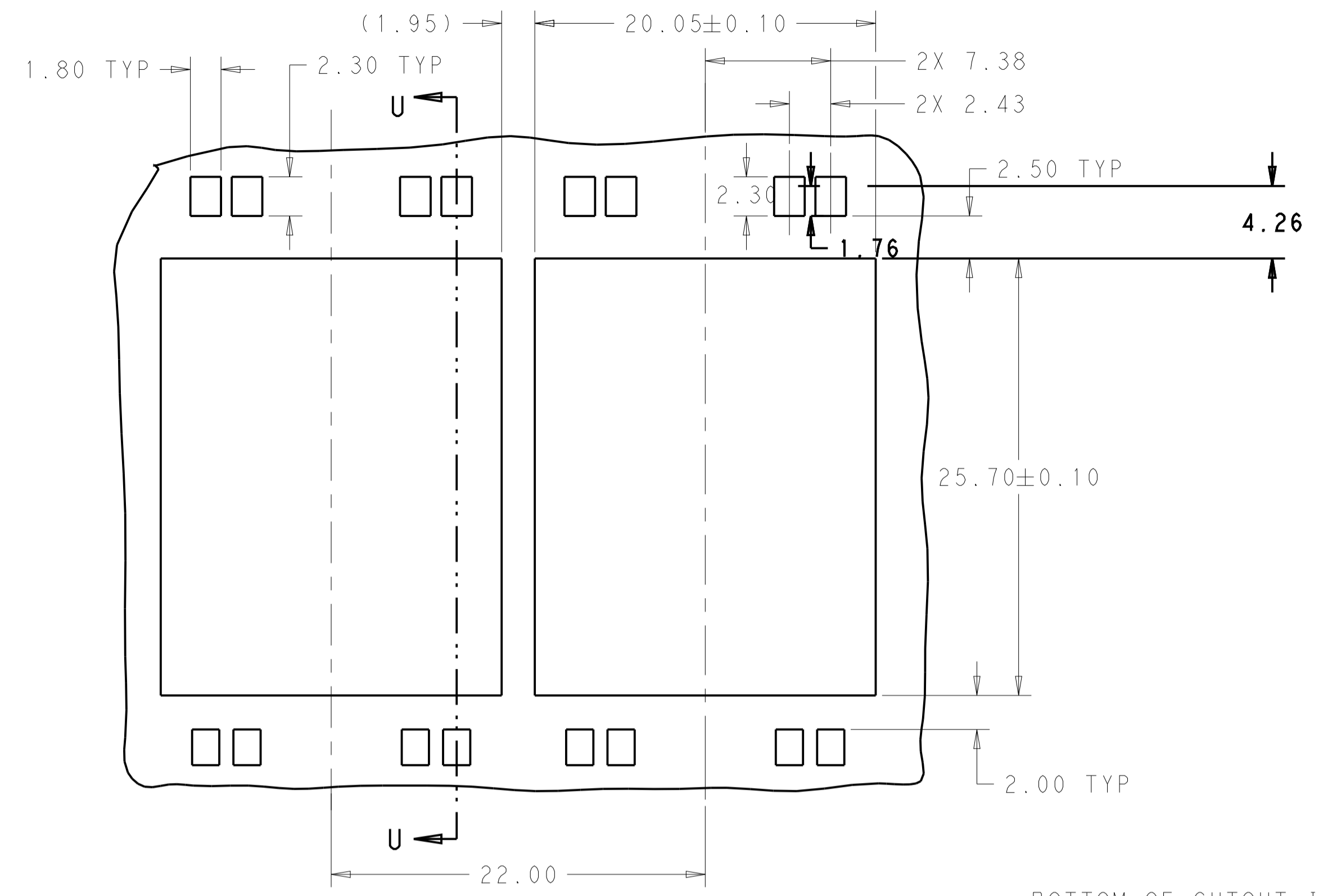

RECOMMENDED PANEL CUTOUT AND PC BOARD, PANEL POSITION

0.10
 BOTTOM OF CUTOUT IN PANEL TO TOP OF PC BOARD

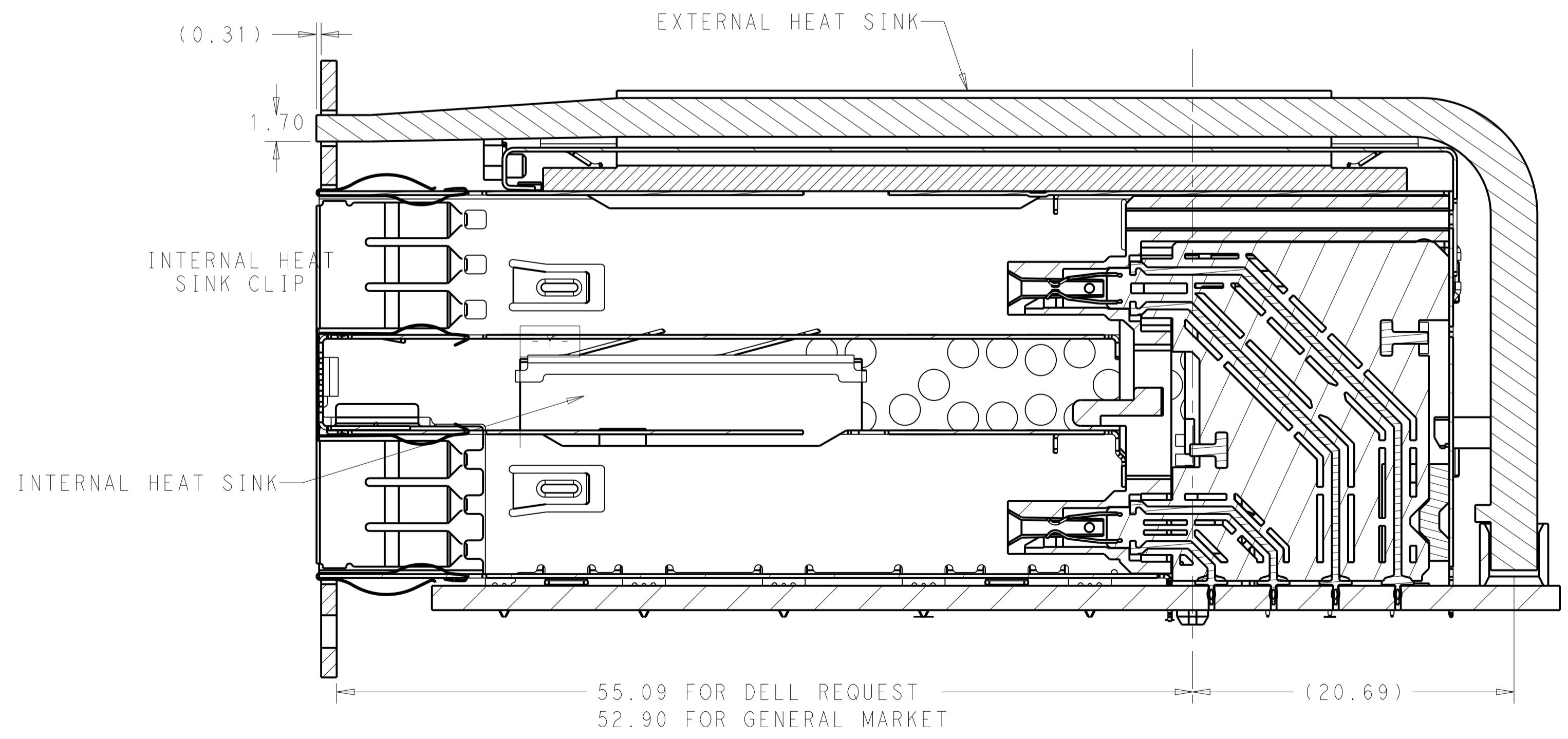
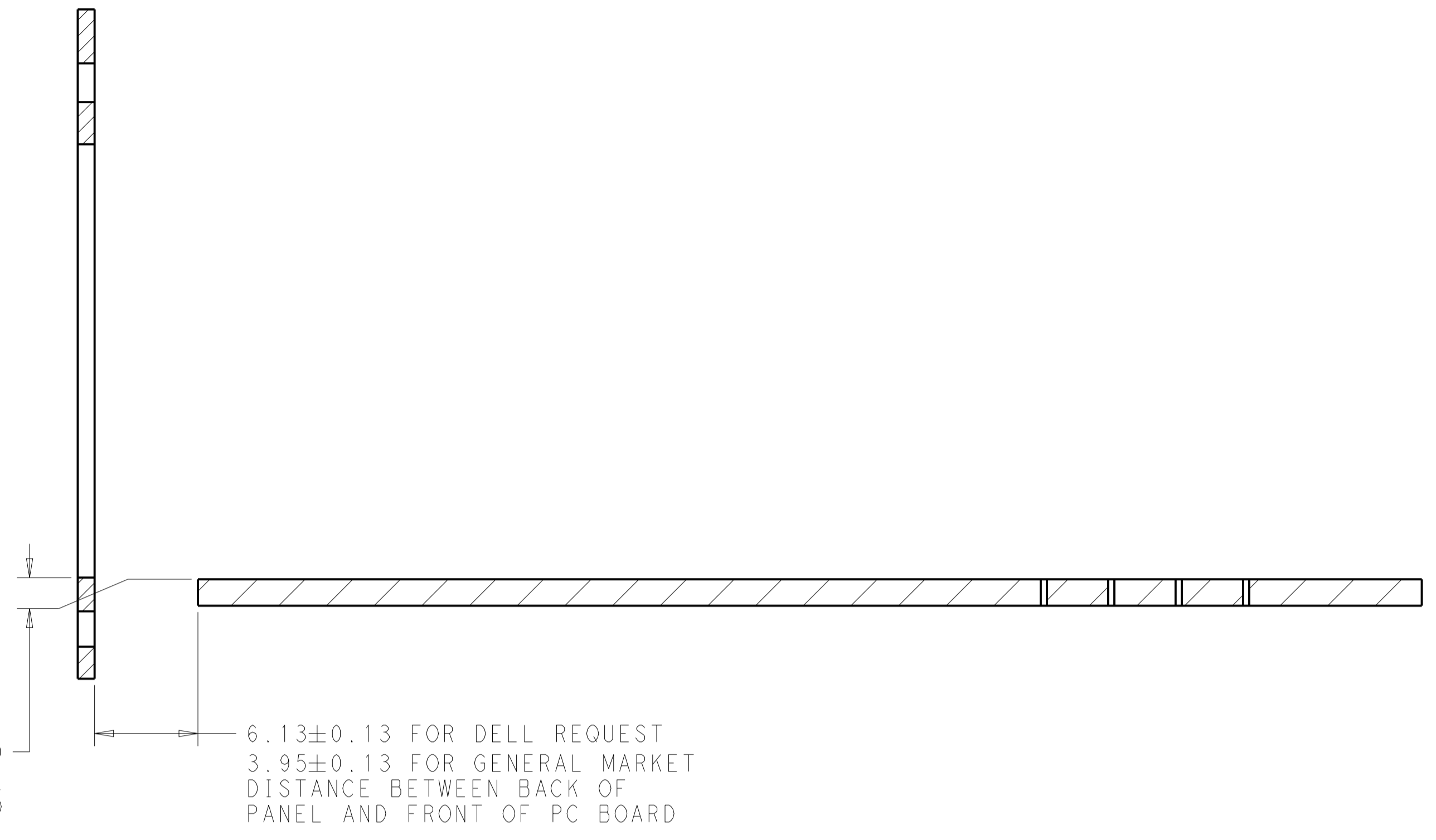

SECTION U-U
 SCALE 4:1

THIS DRAWING IS A CONTROLLED DOCUMENT.		OWN: ARTHUR JIN 02FEB2016	TE Connectivity
DIMENSIONS: mm		CHK: SEAN HAN 02FEB2016	
TOLERANCES UNLESS OTHERWISE SPECIFIED:		APVD: SEAN HAN 02FEB2016	NAME: CAGE AND CONNECTOR ASSEMBLY WITH EMI SPRING FINGERS, THRU BEZEL, 2X1 ZQSF+ STACKED WITH HS
0 PLC ±	1 PLC ±0.25	PRODUCT SPEC	SIZE: A1
2 PLC ±0.15	3 PLC ±	APPLICATION SPEC	CAGE CODE: 2299940
4 PLC ±	ANGLES ±	WEIGHT	SCALE: 4:1
MATERIAL: SEE NOTE 1	FINISH	CUSTOMER DRAWING	SHEET 7 OF 9
		REV C	

LOC		DIST		REVISIONS			
P	LTN	DESCRIPTION	DATE	DMN	APVD		
-	-	SEE SHEET 1	-	-	-	-	-

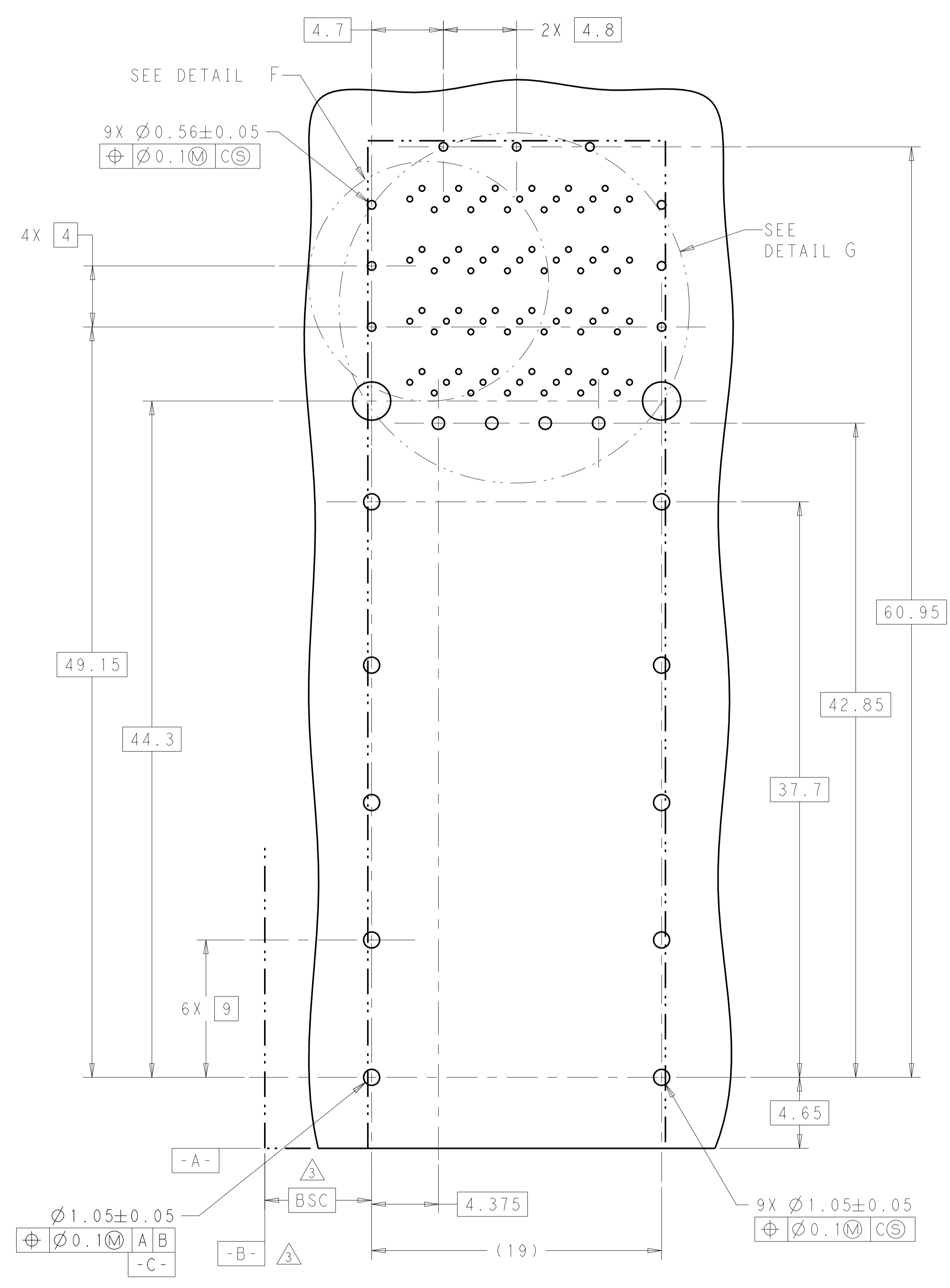

RECOMMENDED PC BOARD LAYOUT
 COMPONENT SIDE OF BOARD
 SCALE 5:1
 (PCB TOLERANCE: ± 0.05)

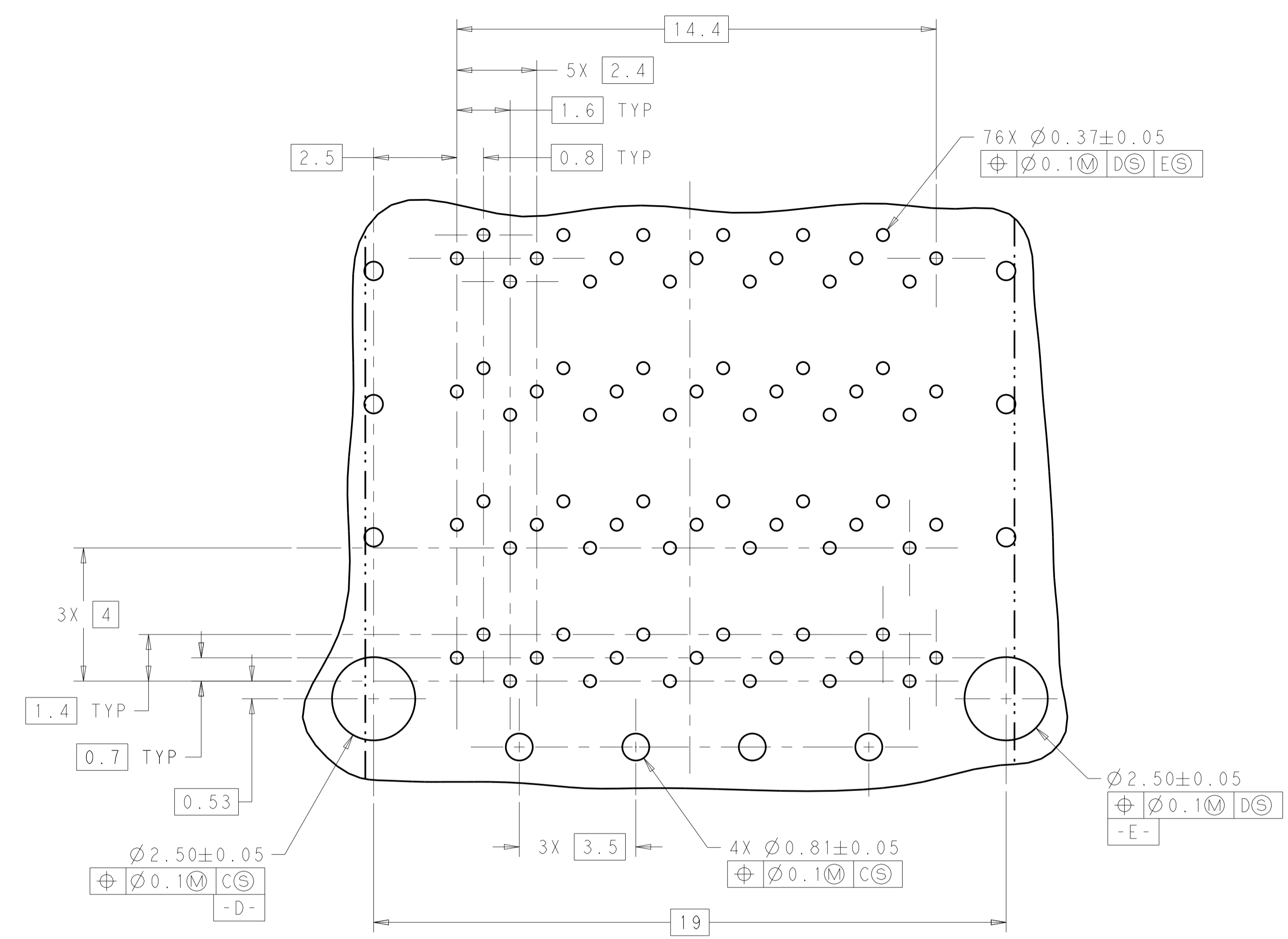

DETAIL G
 SCALE 10:1

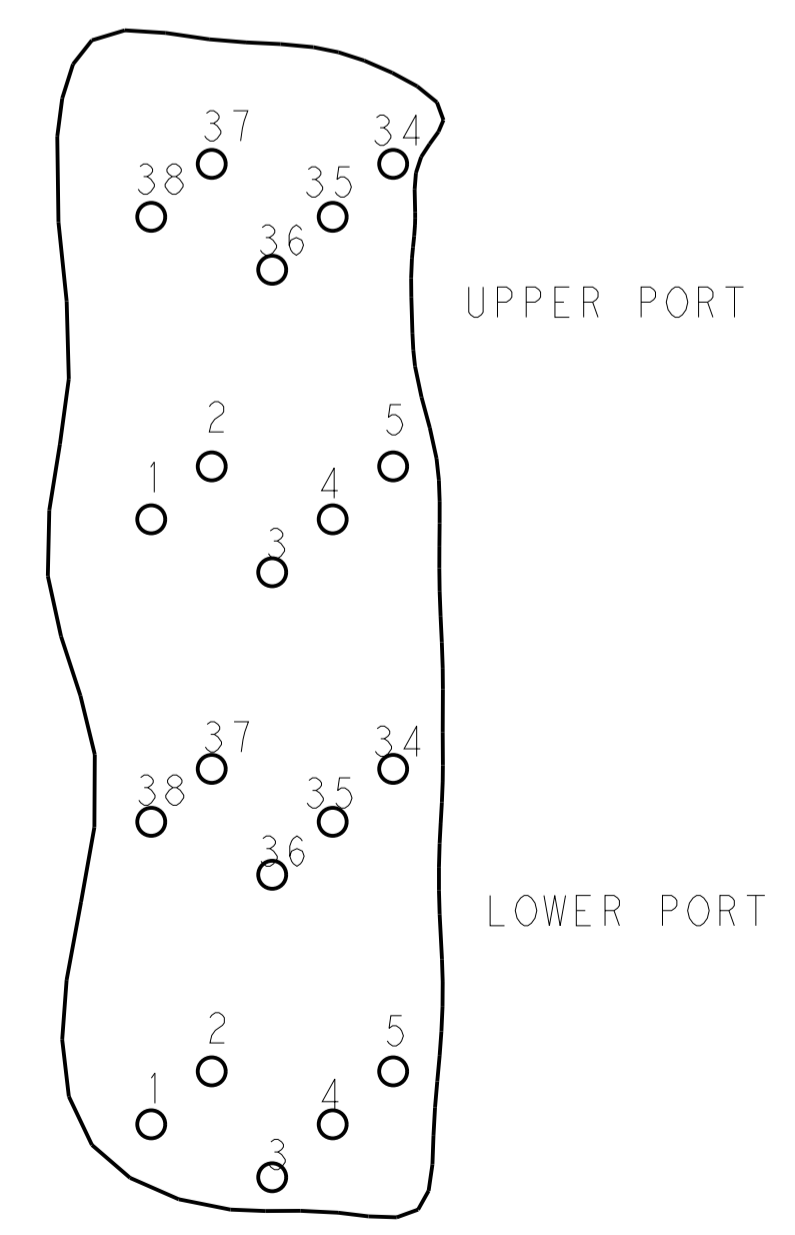

DETAIL F
 SCALE 10:1
 PIN ASSIGNMENTS

THIS DRAWING IS A CONTROLLED DOCUMENT.		DMN: ARTHUR JIN 02FEB2016	TE Connectivity
DIMENSIONS: mm		CHK: SEAN HAN 02FEB2016	
TOLERANCES UNLESS OTHERWISE SPECIFIED:		APVD: SEAN HAN 02FEB2016	NAME: CAGE AND CONNECTOR ASSEMBLY WITH EMI SPRING FINGERS, THRU BEZEL, 2X1 ZQSF+ STACKED WITH HS
0 PLC	±	PRODUCT SPEC	APPLICATION SPEC
1 PLC	±0.25	SIZE	CAGE CODE DRAWING NO
2 PLC	±0.15	WEIGHT	RESTRICTED TO
3 PLC	±	CUSTOMER DRAWING	SCALE 4:1 SHEET 8 OF 9 REV C
4 PLC	±		
ANGLES	±		
MATERIAL	FINISH		
SEE NOTE 1			

LOC		DIST		REVISIONS			
				DESCRIPTION	DATE	DWN	APVD
-	-	-	-	SEE SHEET 1	-	-	-

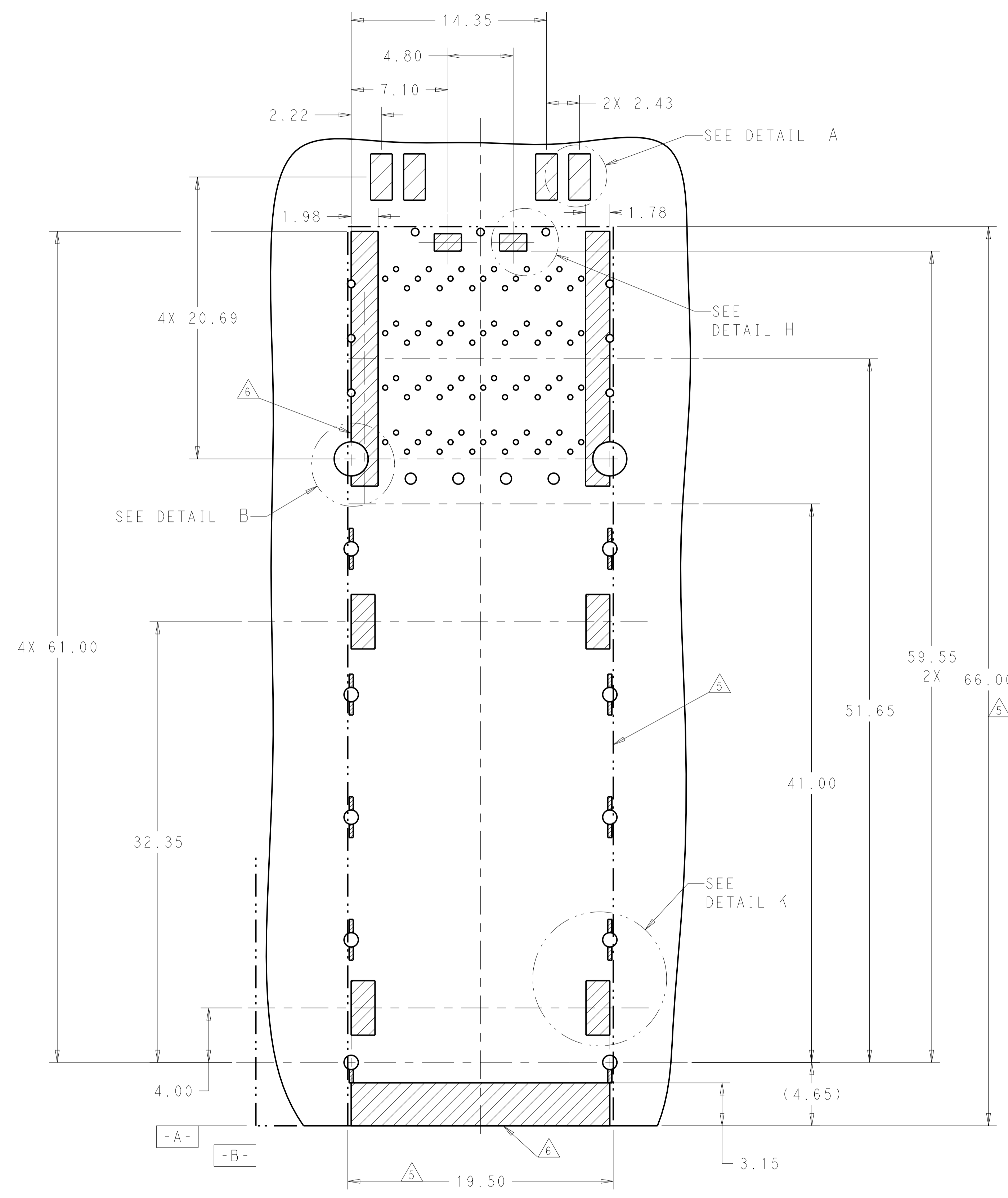

KEEPOUT AREAS FOR 4 LP APPLICATON
 COMPONENT SIDE OF BOARD
 SCALE 5:1

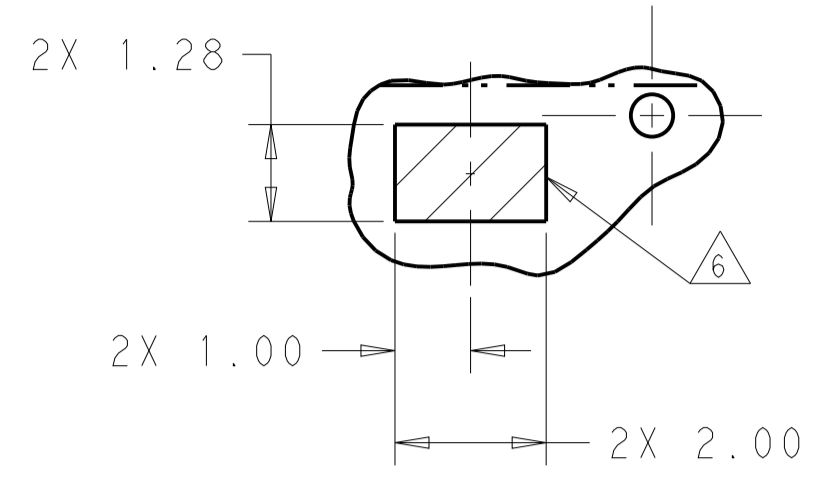

DETAIL H
 SCALE 10:1

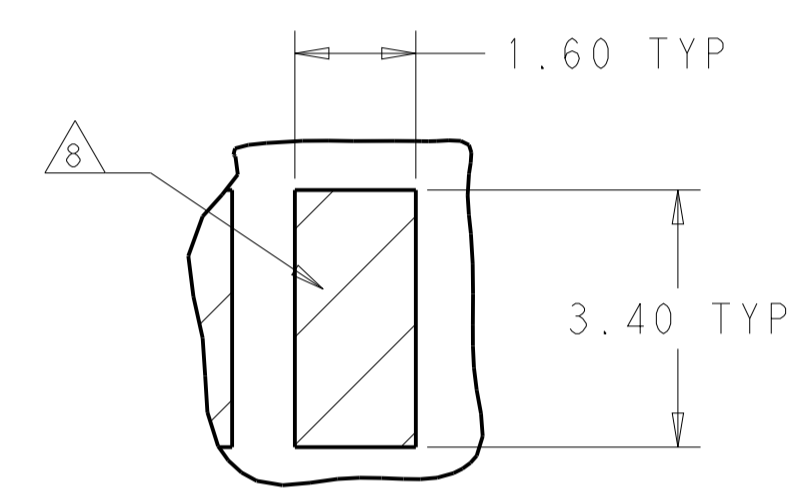

DETAIL A
 LED PADS
 SCALE 10:1

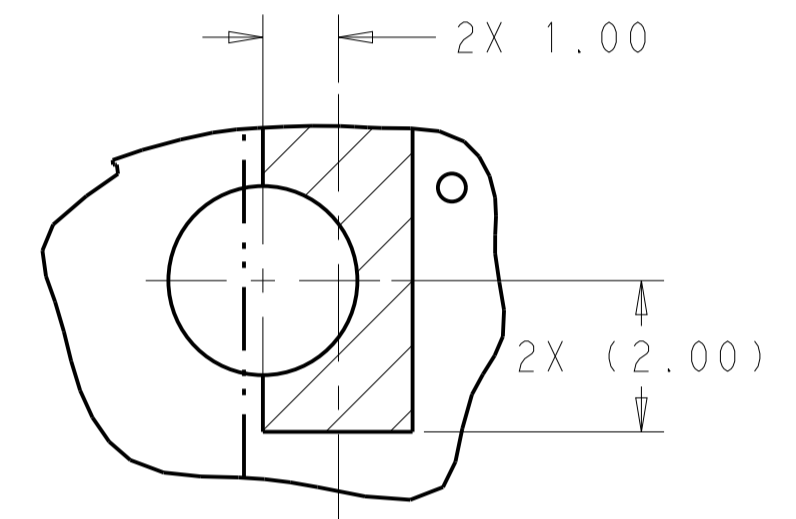

DETAIL B
 SCALE 10:1

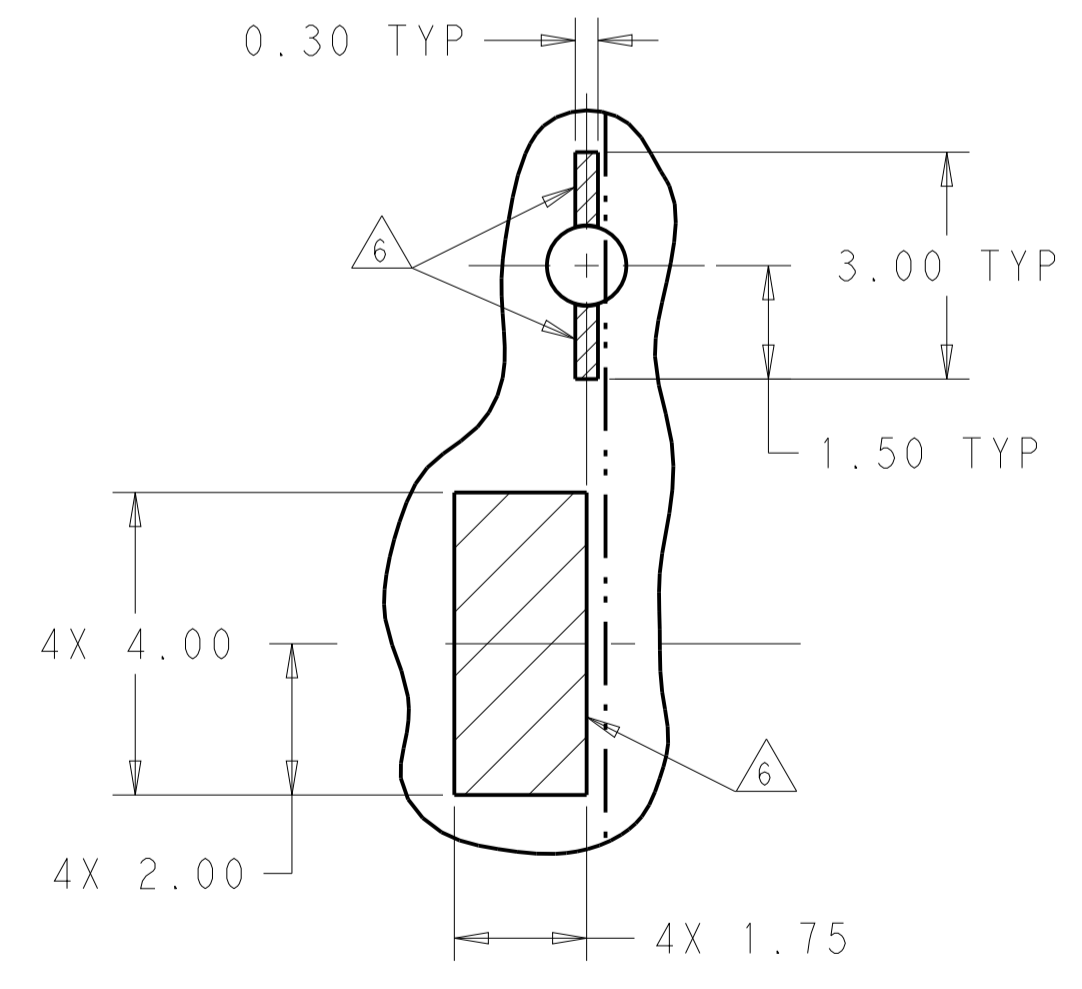

DETAIL K
 SCALE 10:1

THIS DRAWING IS A CONTROLLED DOCUMENT.		DWN: ARTHUR JIN 02FEB2016	TE Connectivity
DIMENSIONS: mm		CHK: SEAN HAN 02FEB2016	
TOLERANCES UNLESS OTHERWISE SPECIFIED:		APVD: SEAN HAN 02FEB2016	NAME: CAGE AND CONNECTOR ASSEMBLY WITH EMI SPRING FINGERS, THRU BEZEL, 2X1 ZQSF+ STACKED WITH HS
0 PLC ± 1 PLC ±0.25 2 PLC ±0.15 3 PLC ± 4 PLC ± ANGLES ±		PRODUCT SPEC: -	SIZE: A1
MATERIAL: SEE NOTE 1		APPLICATION SPEC: -	CAGE CODE: 2299940
		WEIGHT: -	RESTRICTED TO: -
		CUSTOMER DRAWING	SCALE: 1:1 SHEET 9 OF 9 REV C

X-ON Electronics

Largest Supplier of Electrical and Electronic Components

Click to view similar products for [I/O Connectors](#) category:

Click to view products by [TE Connectivity](#) manufacturer:

Other Similar products are found below :

[571763P](#) [58098-0628](#) [72.250.1628.2](#) [72.250.2428.2](#) [74720-0505](#) [76.350.0729.0](#) [76871-1403](#) [FCN-244F080-G/1](#) [FCN-260A9920](#) [PCR-E36PM](#) [PCS-XE26MA+](#) [G38A71314B](#) [1571250010](#) [157-22500-3](#) [MS3471L14-19P L/C](#) [172501-4002](#) [172501-6002](#) [FCN-260C008-A/L0](#) [FCN-260C024-AL0](#) [FCN-261Z008](#) [2000314-1](#) [200331-1](#) [PCR-E36FC+](#) [PCS-E28FS+](#) [PCS-XE26SLFD+](#) [PCS-XE26SLFDT+](#) [G730VID08BDC24](#) [U90B2054081210](#) [38113800006](#) [DP3AR020WQ1R200](#) [Z4.102.0680.0](#) [500-1040](#) [500-1052](#) [500-1054](#) [ZP-4008-66L](#) [0709821002](#) [DX40-20P\(55\)](#) [5554841-1](#) [MS3474W18-8P-LC*](#) [U90B3054061110](#) [U65-E04-4020](#) [ZPF000000000097891](#) [747360449](#) [10099439-003C-TRLF](#) [10137239-0021LF](#) [E9320-001-01](#) [10137239-0011LF](#) [70289-001LF](#) [70.060.1028.0](#) [109029-ZZ](#)