

PROJECT NO. PRJ-15-000001872		REVISIONS		
REV	DATE	DESCRIPTION	BY	APPD
A2	14APR2017	ADDED SERIES PART	MSA	AB
A3	31JAN2019	DRAWING UPDATE	AN	AB
A4	08FEB2020	ECR-20-002001	SK	AB
A5	09APR2020	ECR-20-005202	KK	AB

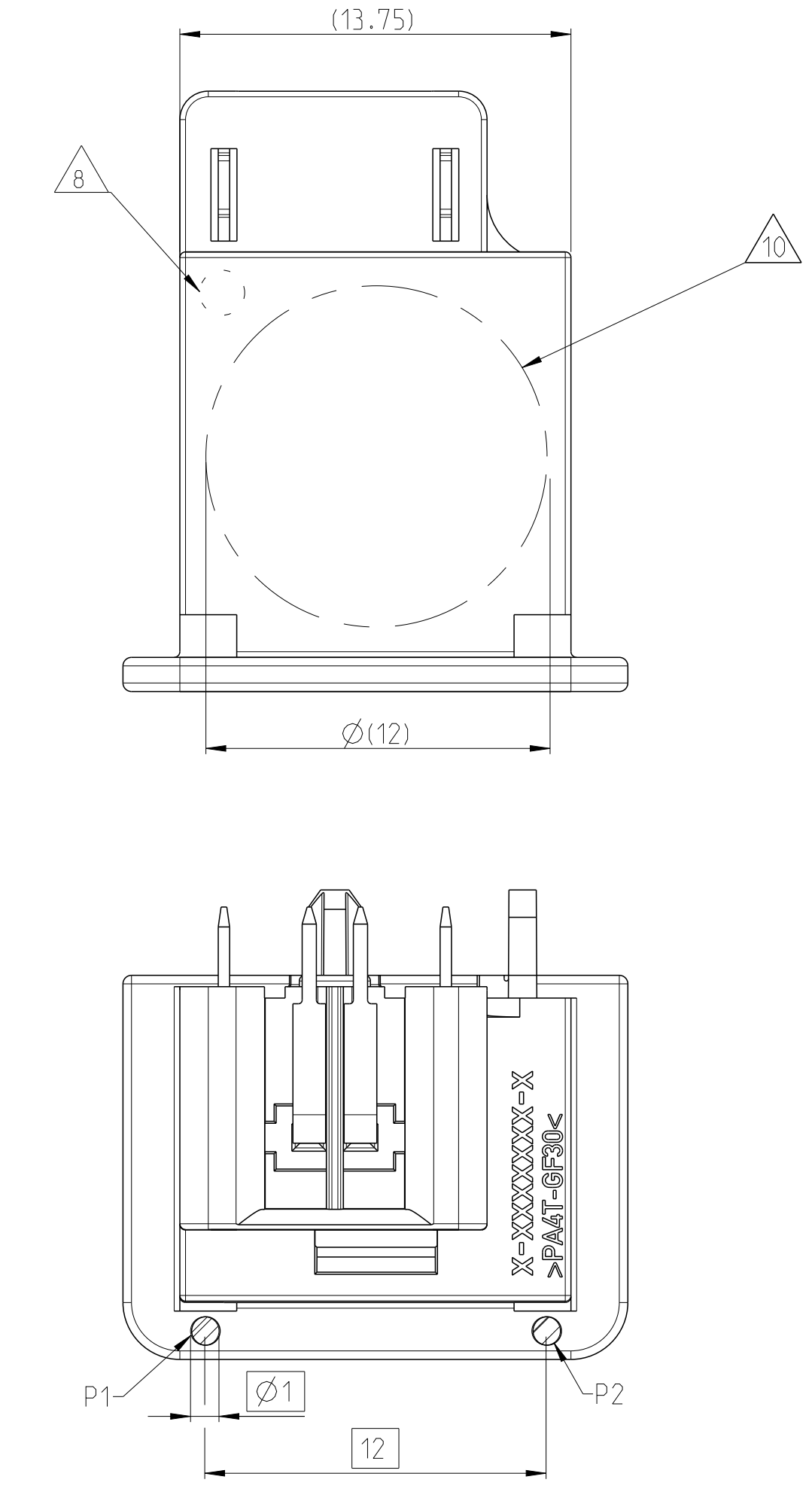
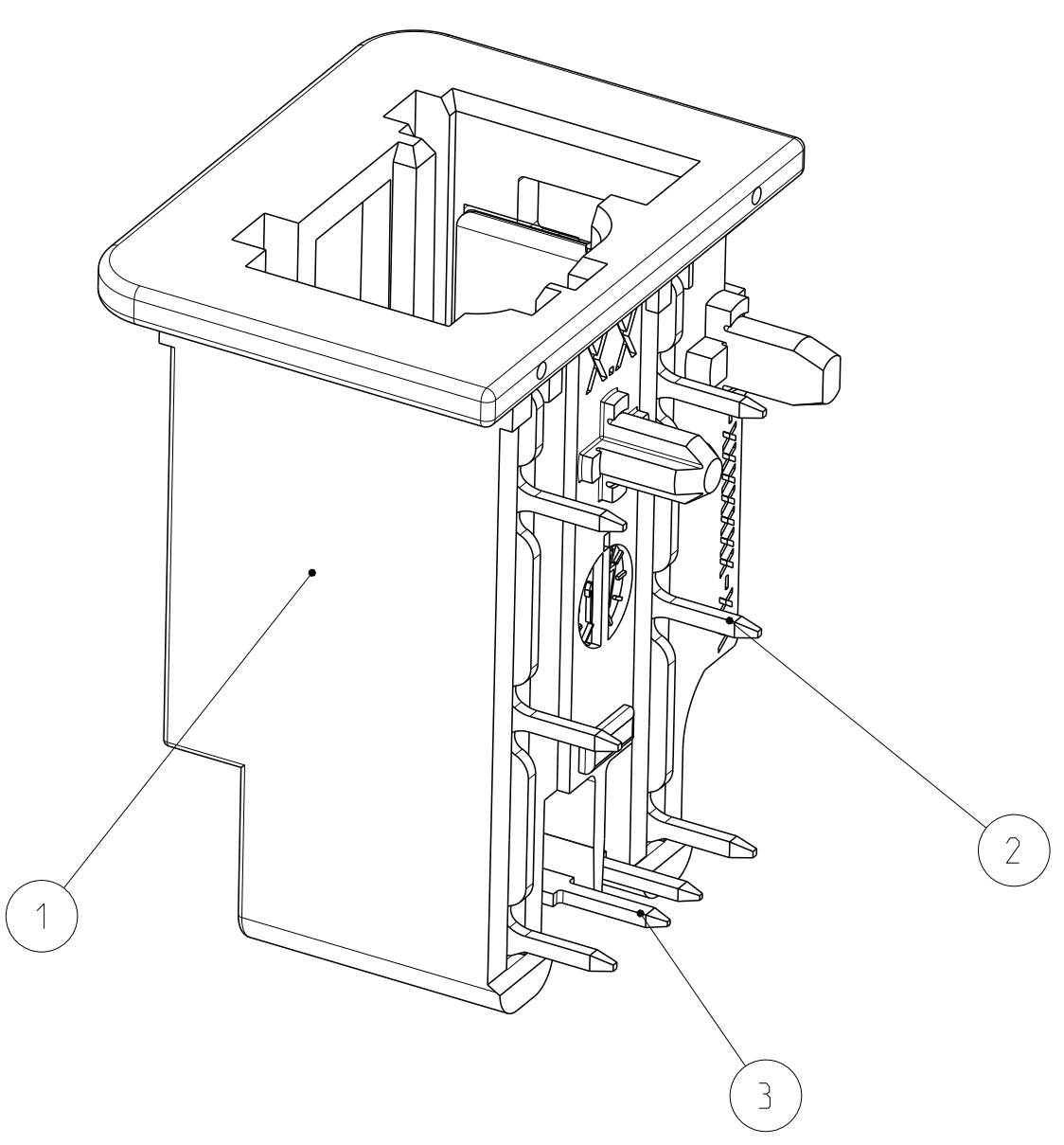
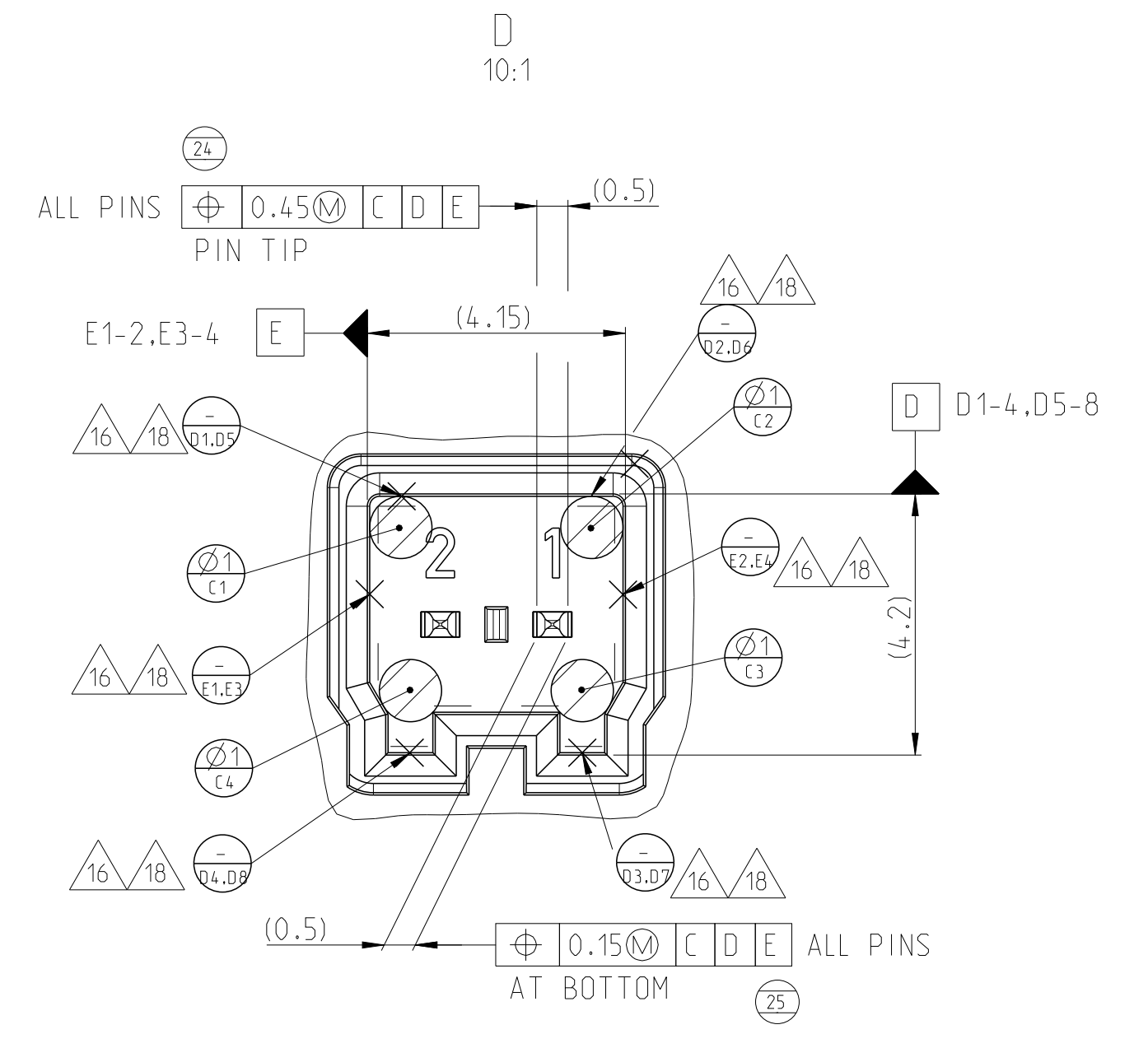
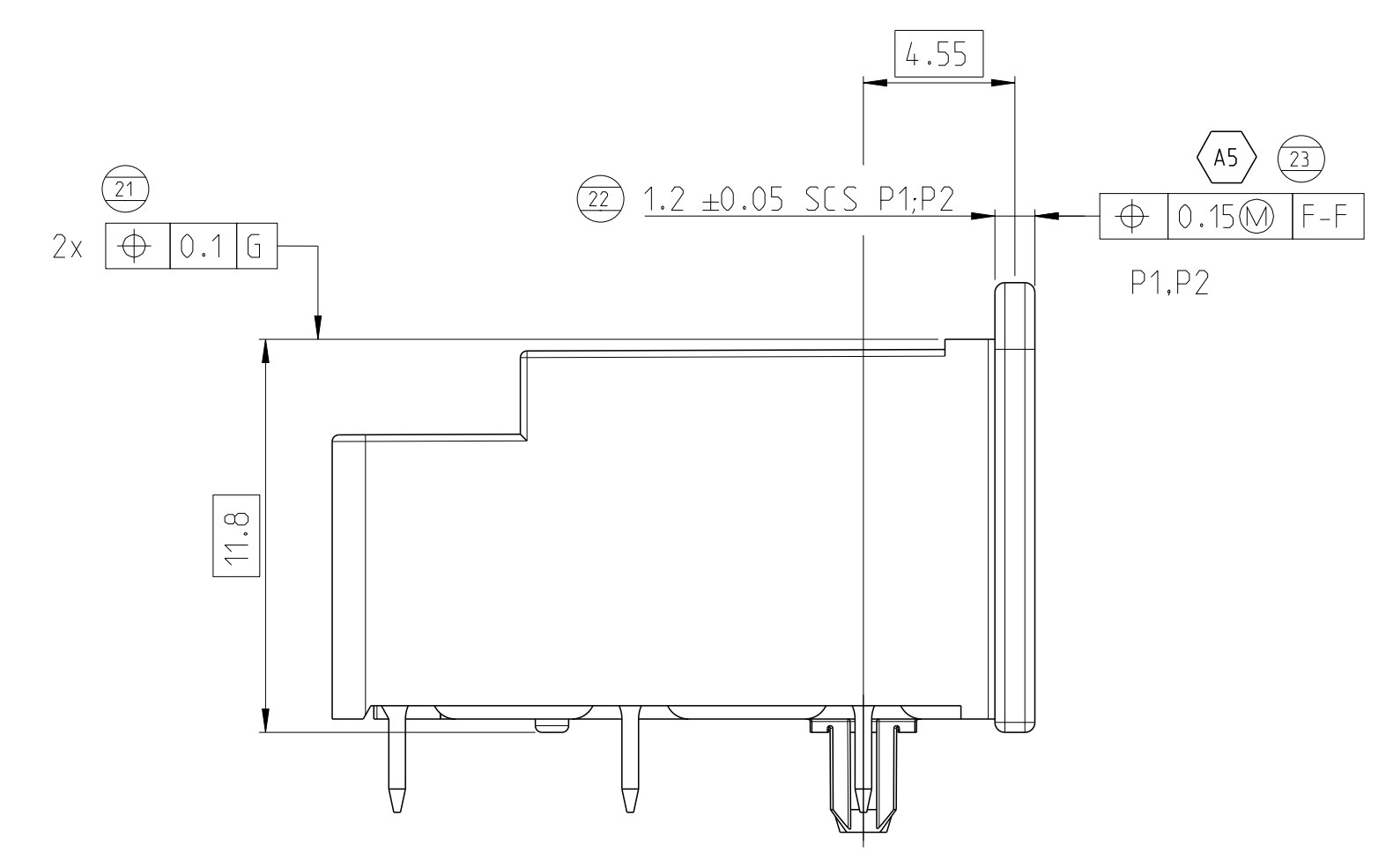
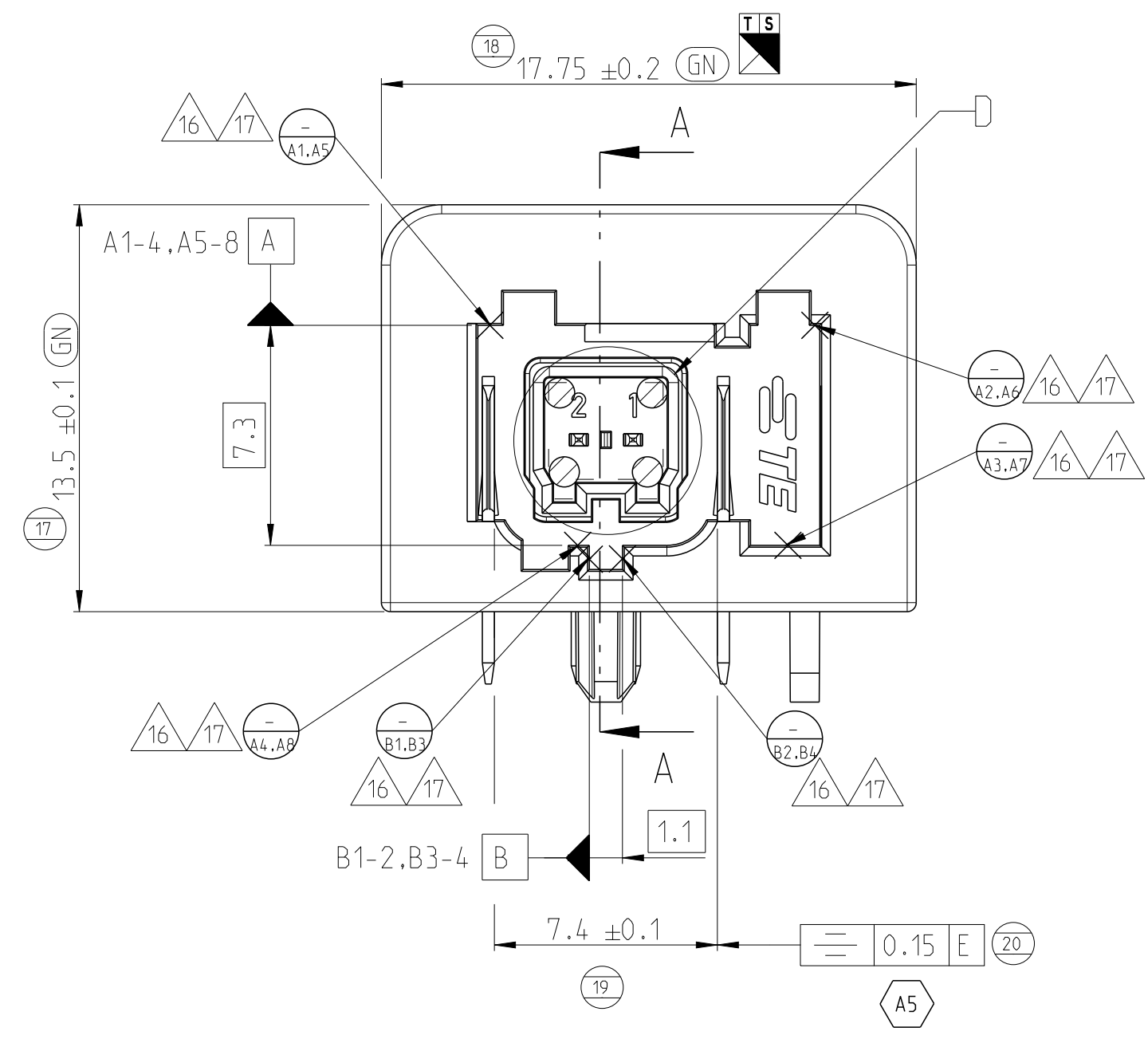
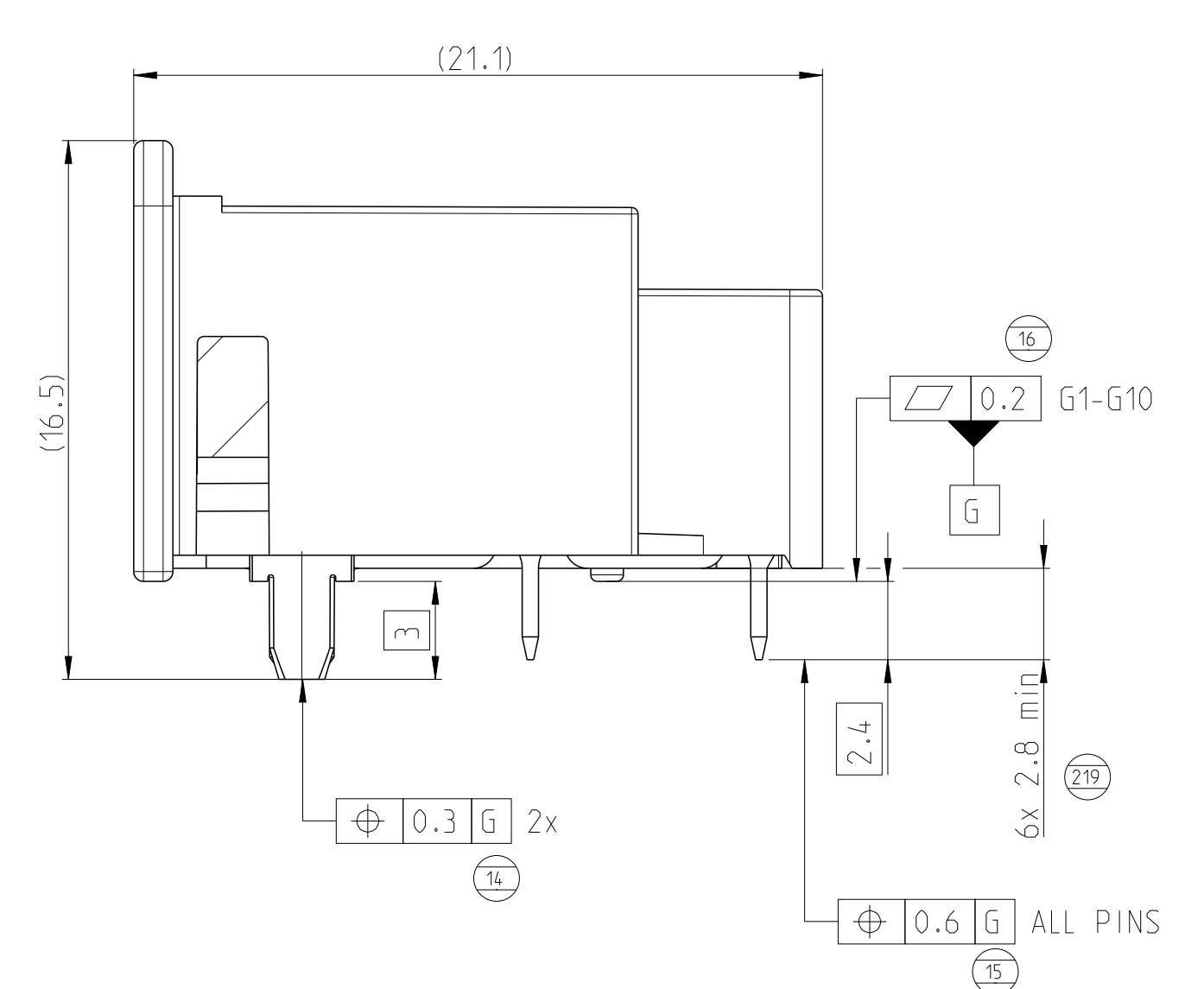
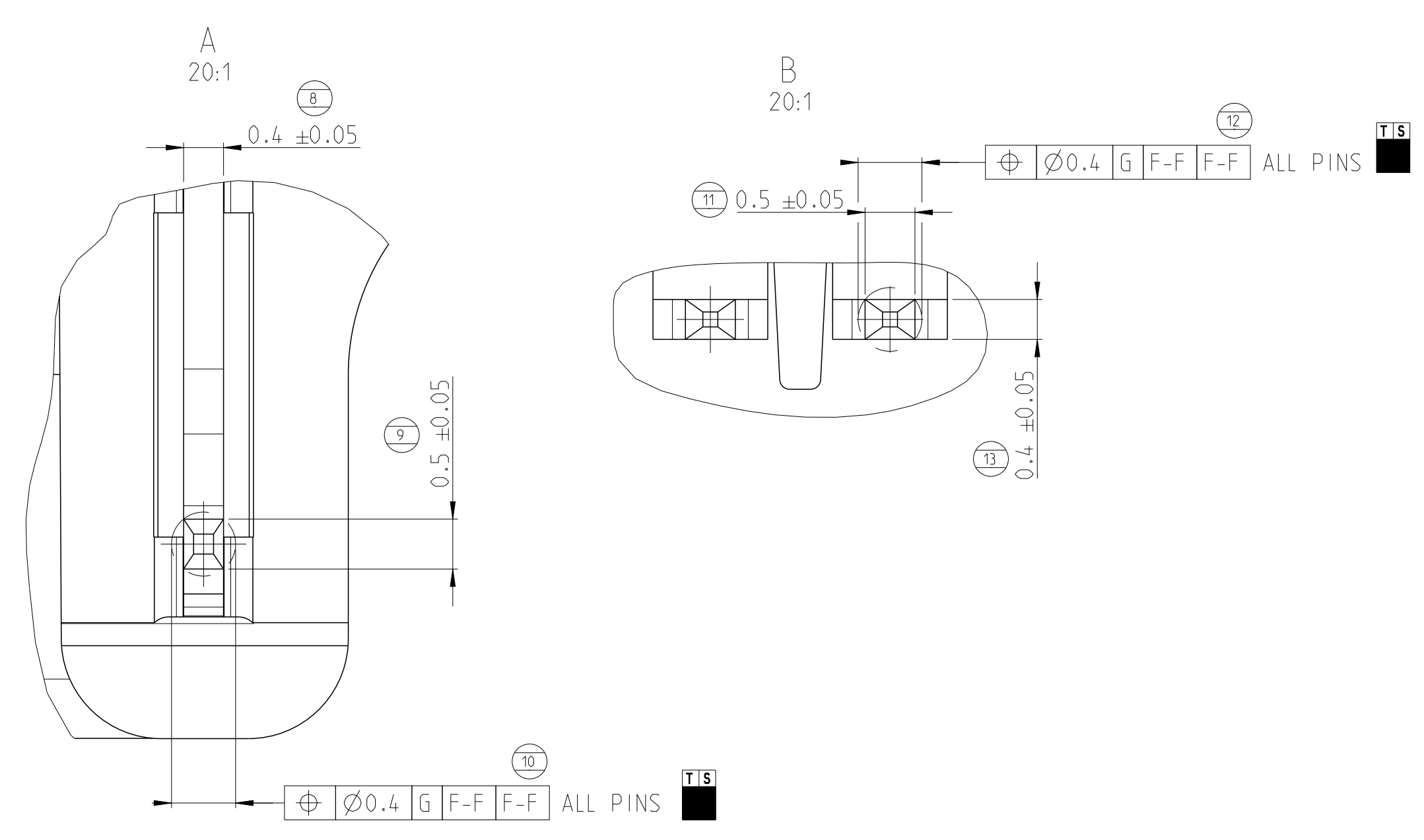
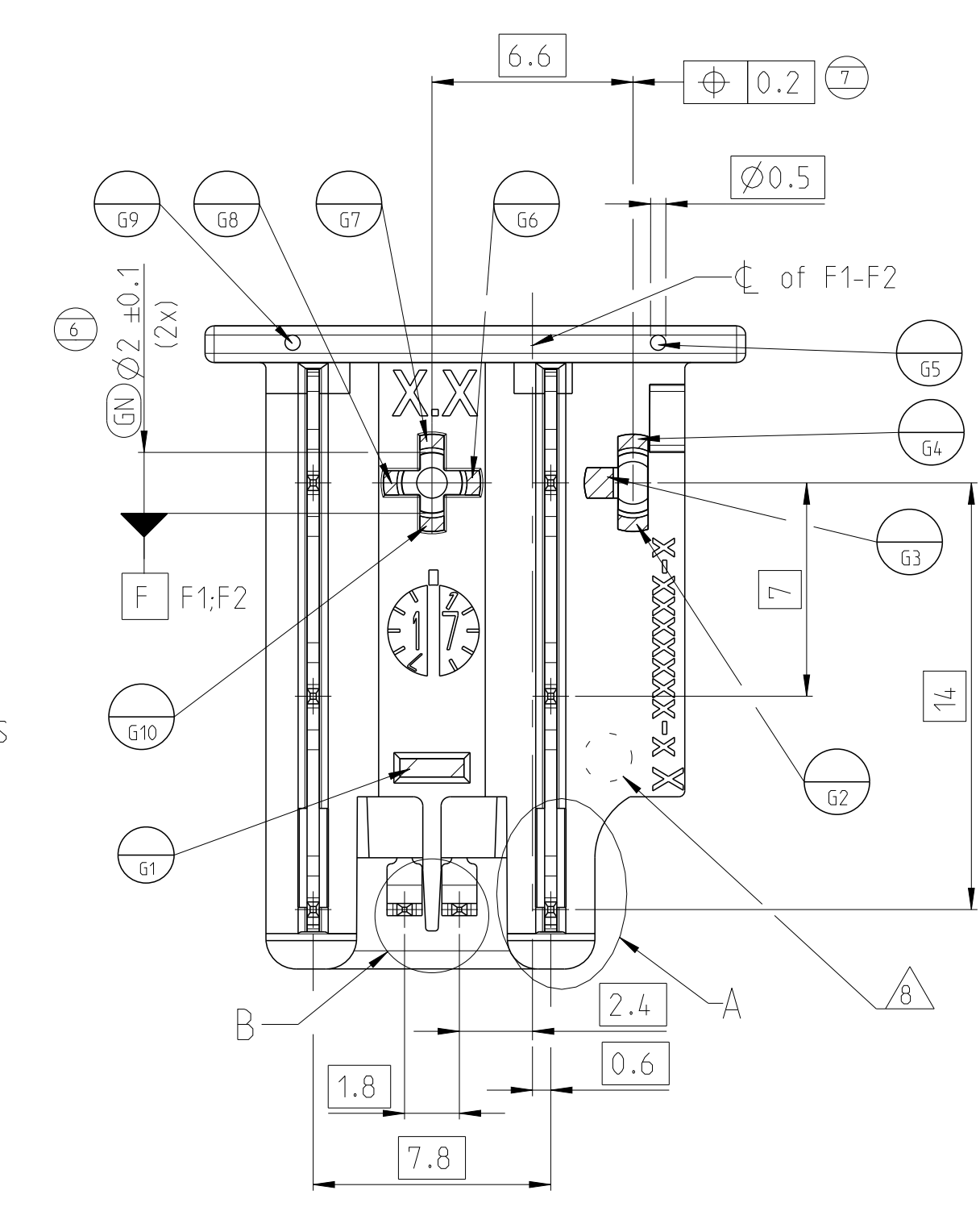
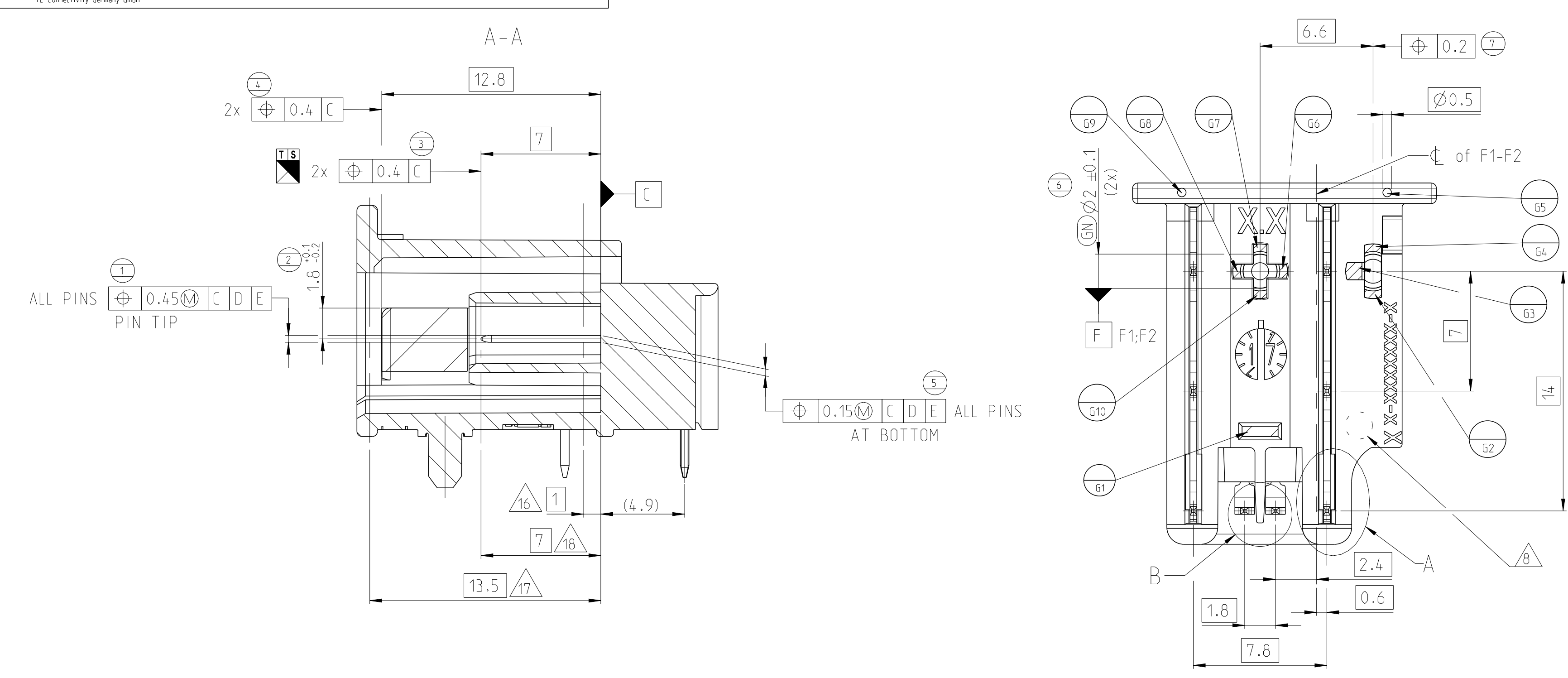

- NOTES
Bemerkungen
- 1 PRESS OUT FORCE FOR NANOMOS CONTACT >15N WITH FEED RATE 25mm/min
Kontakt ausdruckkraft fuer NanoMOS Kontakt >15N mit Vorschubgeschwindigkeit 25mm/min
 - 2 INTERFACES AND COLOUR ACC. TO 208-18006, REV. A4, 26MAR2020
Schnittstellen und Farbe nach 208-18006, REV. A4, 26MAR2020
 - 3 SOLDERING PROCESS: LEAD-FREE REFLOW SOLDERING IN REFERENCE TO JEDEC J-STD-0200
Loelprozess: Bleifreies Loeten in Anlehnung an die JEDEC J-STD-0200
 - 4 TOLERANCES ACC. TO DIN EN ISO 8015, DIN EN ISO 14405-1
GENERAL TOL. ACC. TO DIN 16742 T65, EXCEPT ANGLE DIM. (SEE TITLE BLOCK)
Tolerierung nach DIN EN ISO 8015, DIN EN ISO 14405-1
Allgemeintoleranzen nach DIN 16742 T65, ausser Winkelmasse (siehe Schriftkopf)
 - 5 PACKAGING IN TAPE & REEL ACC. TO V2304372
Verpackung in Tape & Reel nach V2304372
 - 6 CONTACT SURFACE SOLDER SIDE 3-8µm Sn OVER 1-2.5µm Ni
Kontaktoberflaeche Loetseifig 3-8µm Sn ueber 1-2.5µm Ni
 - 7 FOR MISSING DIMENSION SEE CAD-MODEL 2304372-X, REV. A
Fehlende Masse sind dem CAD-Model 2304372-X, Rev. A zu entnehmen
 - 8 GOOD PART MARKING PUNCH MARKED
Guteilemarkierung Koernerpunkt
 - 9 ELECTRICAL 100% FINAL INSPECTION FOR CONTINUITY AND SHORT CIRCUIT
AS WELL AS EXISTENCE OF ALL CONTACTS
Elektrische 100% Endpruefung auf Durchgang und Kurzschluss,
sowie das Vorhandensein aller Kontakte
 - 10 VACUUM GRIP AREA FREE OF BURR AND EJECTOR PINS
Ansaugflaeche frei von Grat und Auswerferstiften
 - 11 -
 - 12 HEADER FULFILL RF-REQUIREMENTS UP TO 1GHz ACC. TE SPEC. 108-94509, ALSO MANDATORY IS
A PCB COPPER LAYER ACC. TO TE SPEC. 114-94448
Der Header erfuehlt die RF-Anforderungen bis zu 1 GHz nach TE Spez. 108-94509. Ebenfalls
notwendig ist eine Leiterplatten Kupferschicht nach TE Spec. 114-94448
 - 13 HEADER FULFILL RF-REQUIREMENTS UP TO 100 Mhz ACC. TE SPEC. 108-94444
Der Header erfuehlt die RF-Anforderungen bis zu 100Mhz nach TE Spez. 108-94444
 - 14 APPLICATION SPECIFICATION ACC. TO 114-94448
Anwendungsspezifikation TE Spez. 114-94448
 - 15 Corresponding mating connector see drawing C-2302510 or C-2302454 and Product Spec. 108-94568
Passender Gegenstecker siehe Zeichnung C-2302510 or C-2302454 und Produktspez. 108-94568
 - 16 REFERENCE POINTS A1-A4, B1-B2, D1-D4, E1-E2 TO BE TAKEN IN SHOWN HEIGHT
Bezugspunkte A1-A4, B1-B2, D1-D4, E1-E2 sind in angegebener Hoehe zu ermitteln
 - 17 REFERENCE POINTS A5-A8, B3-B4 TO BE TAKEN IN SHOWN HEIGHT
Bezugspunkte A5-A8, B3-B4 sind in angegebener Hoehe zu ermitteln
 - 18 REFERENCE POINTS D5-D8, E3-E4 TO BE TAKEN IN SHOWN HEIGHT
Bezugspunkte D5-D8, E3-E4 sind in angegebener Hoehe zu ermitteln

2304372-1 COD. A AS SHOWN wie gezeichnet

2304372-1_COD_A AS SHOWN wie gezeichnet
 2304372-2_COD_B AS SHOWN wie gezeichnet
 2304372-3_COD_C AS SHOWN wie gezeichnet
 2304372-7_COD_J AS SHOWN wie gezeichnet
 2304372-9_COD_Z AS SHOWN wie gezeichnet

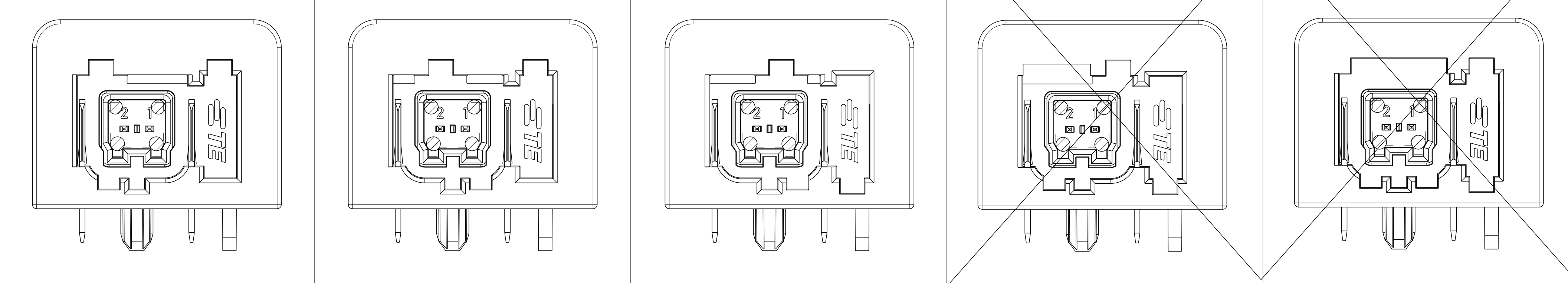

RECOMMENDED PCB LAYOUT / Empfohenes PCB Layout
 CUSTOMER IS RESPONSIBLE FOR LAYOUT / Kunde ist fuers Layout verantwortlich

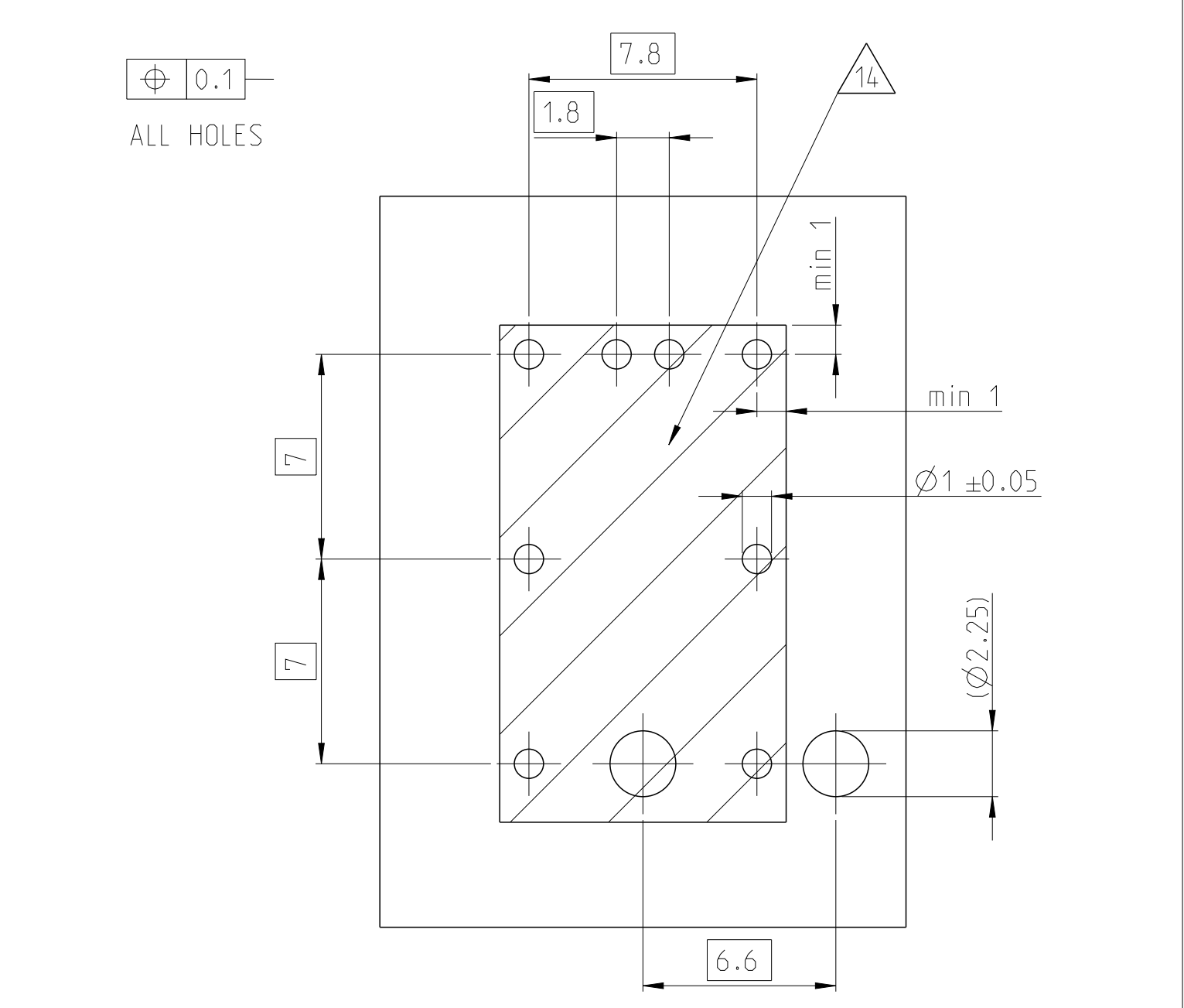

- 100% Inspection
100% Pruefung
- Cmk >= 1.67
Cmk >= 1.67
- ROUTINE INSPECTION
Routine Pruefung

TE ORDER NO.	WEIGHT [g]	COLOUR	CODING	REV	QTY.	DESCRIPTION	MATERIAL	POS.
2304372-9	3	WATER BLUE	Z	A	2	Nano MOS TAB 90° Sn	Cu-Alloy	3
					1	Shield	Cu-Alloy	2
					1	1 Port 90° HSG COD.Z	PA&T-GE30	1
2304372-7	3.08	BEIGE	J	A	2	Nano MOS TAB 90° Sn	Cu-Alloy	3
					1	Shield	Cu-Alloy	2
					1	1 Port 90° HSG COD.J	PA&T-GE30	1
2304372-3	3.11	BLUE	C	A	2	Nano MOS TAB 90° Sn	Cu-Alloy	3
					1	Shield	Cu-Alloy	2
					1	1 Port 90° HSG COD.C	PA&T-GE30	1
2304372-2	3.1	WHITE	B	A	2	Nano MOS TAB 90° Sn	Cu-Alloy	3
					1	Shield	Cu-Alloy	2
					1	1 Port 90° HSG COD.B	PA&T-GE30	1
2304372-1	3.08	BLACK	A	A	2	Nano MOS TAB 90° Sn	Cu-Alloy	3
					1	Shield	Cu-Alloy	2
					1	1 Port 90° HSG COD.A	PA&T-GE30	1

THIS DRAWING IS A CONTROLLED DOCUMENT. DATE: 03JUN2016
 DIMENSIONS: INCH/MILLIMETERS
 MATERIAL: -
 FINISH: -
 WEIGHT: -
 RESTRICTED CUSTOMER

TE Connectivity
 1 PORT HEADER ASSY
 1 Part Header ASSY
 A 00779 C=2304372
 SCALE: 5:1 SHEET 1 of 2 REV: A5

REVISIONS				
NO.	DATE	DESCRIPTION	DATE	APPD.
-	-	SEE SHEET 1	-	-

MATED WITH CONNECTOR

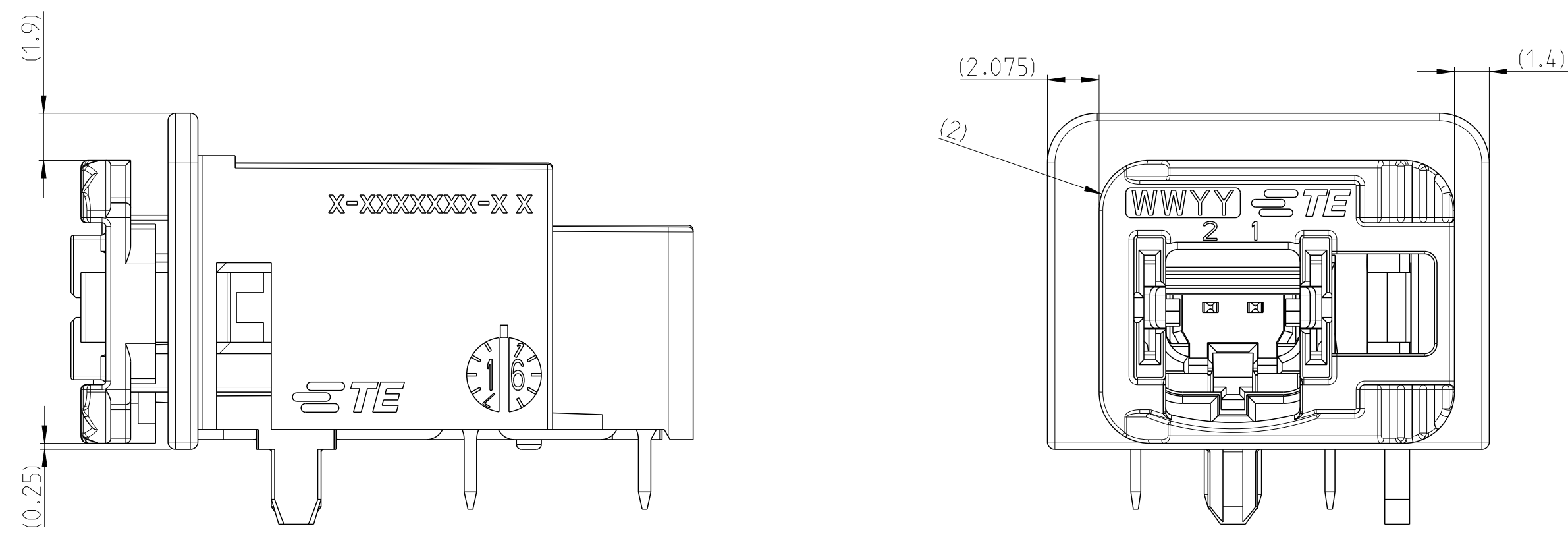

POSSIBLE FIXTURE OF HEADER

CONTACT POINTS FOR AGGREGAT CASE

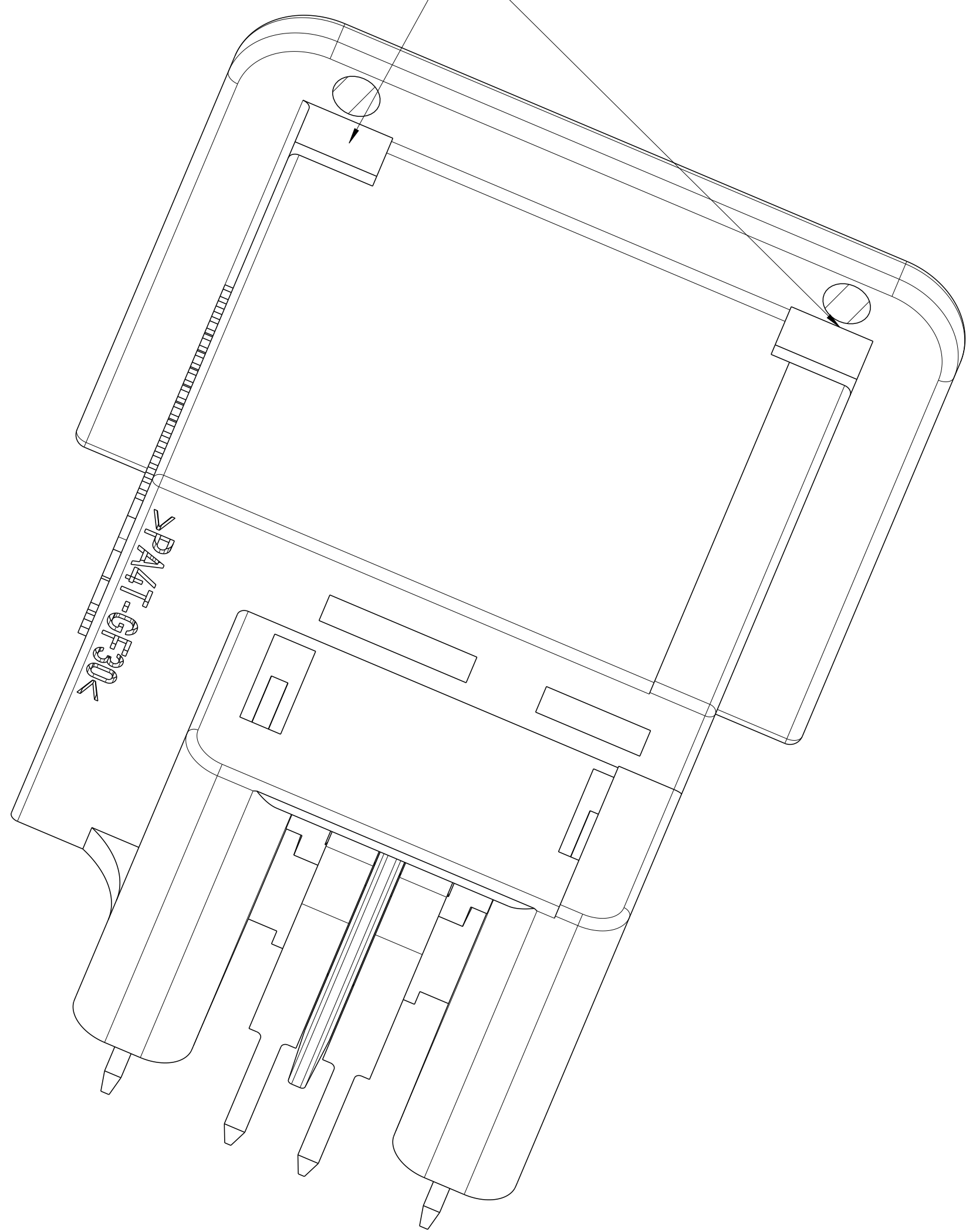

PROPOSAL CASE

AGGREGATE CASE

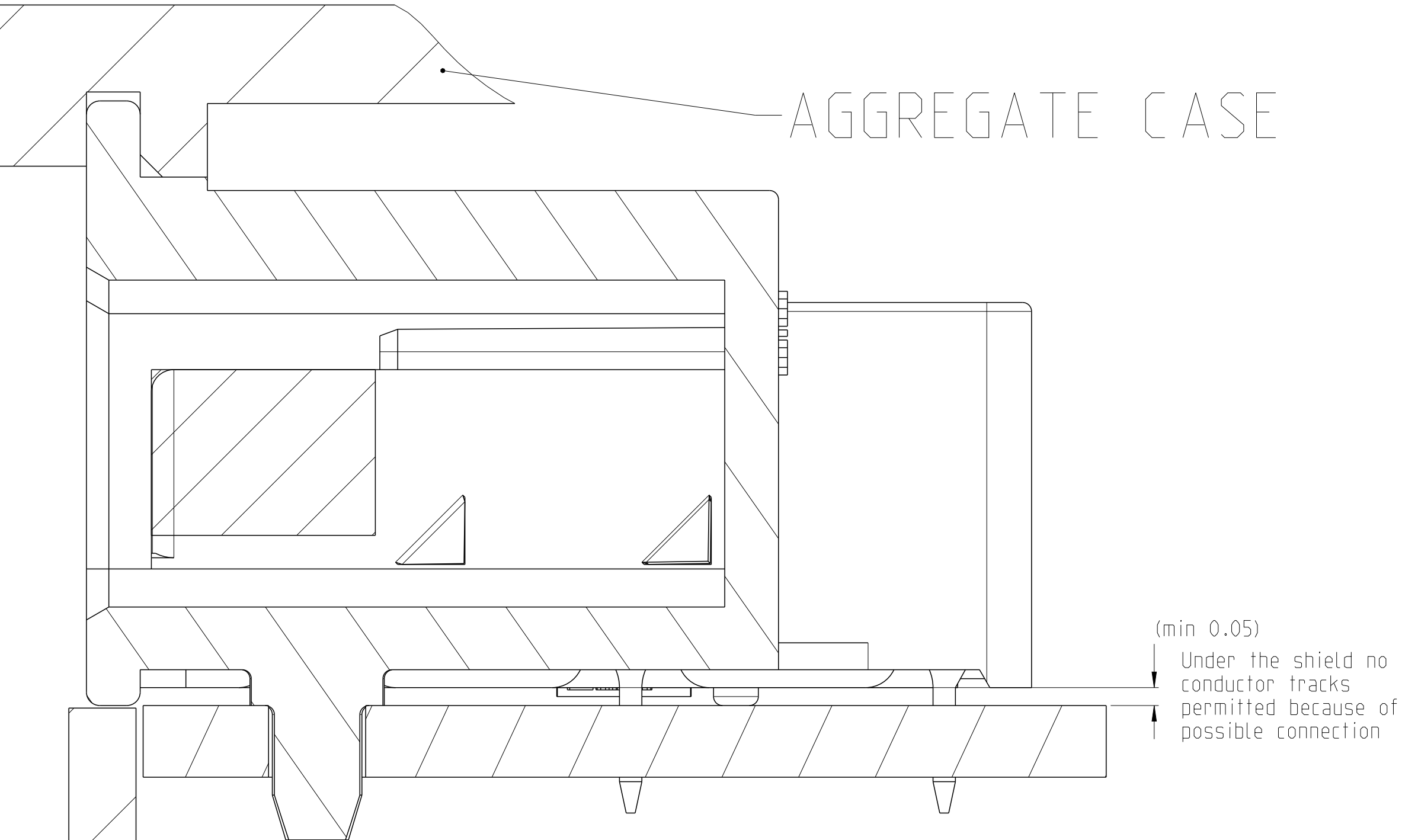

THIS DRAWING IS A CONTROLLED DOCUMENT.		DATE: 03JUN2016	TE Connectivity	
DIMENSIONS:	UNLESS OTHERWISE SPECIFIED:	CHK: A. Burkhard	03JUN2016	NAME: 1 PORT HEADER ASSY
FORM:	PLC	APPD: S. Eibenling	PRODUCT SPEC:	1 Part Header ASSY
	PLC	APPROVAL:		
	PLC	APPLICATION SPEC:		
MATERIAL:	FINISH:	WEIGHT:	SIZE: A0	CAGE CODE: 00779
			DRAWING NO: C=2304372	RESTRICTED TO:
		RESTRICTED CUSTOMER	SCALE: 5:1	SHEET: 2 of 2
				REV: A5

X-ON Electronics

Largest Supplier of Electrical and Electronic Components

Click to view similar products for [Automotive Connectors](#) category:

Click to view products by [TE Connectivity](#) manufacturer:

Other Similar products are found below :

[003-018-000](#) [60403001](#) [60993906-B](#) [M902-2131](#) [M902-2161](#) [72.330.1035.1](#) [73.353.4028.0](#) [F119300-B](#) [F166900](#) [F258300-B](#) [F358300-B](#)
[F407400](#) [F444110](#) [F487000](#) [F509500B-B](#) [827153-1](#) [8N1515-32-24P](#) [9-1326729-8](#) [925474-1](#) [928905-1](#) [964562-4](#) [968782-1](#) [GT17SA-8DS-](#)
[HU](#) [98891-1012](#) [98947-1016](#) [12004147](#) [12004475-L](#) [12010290](#) [12010309-B](#) [12015454](#) [12020219-B](#) [12020308](#) [12041318-B](#) [12052225-L](#)
[12052466](#) [12059125](#) [12064869](#) [12004327-B](#) [12010503-B](#) [12015308](#) [12015384](#) [12015909](#) [1-21030-1](#) [12041254](#) [12041318](#) [12047946-B](#)
[12047957](#) [12047957-L](#) [12059473](#) [12066261](#)