

THIS DRAWING IS UNPUBLISHED. RELEASED FOR PUBLICATION
 © COPYRIGHT 2017 TE CONNECTIVITY ALL RIGHTS RESERVED.

| REVISIONS | | | | |
|-----------|-----|-----------------------|-----------|-------|
| P | LTR | DESCRIPTION | DATE | APVD |
| | A | RELEASE TO PRODUCTION | 01APR2020 | AY PS |
| | | | | |
| | | | | |

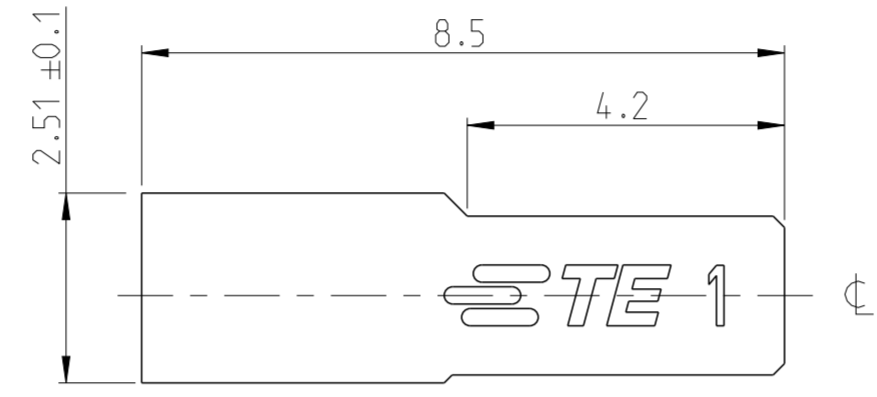

- NOTES:
- MATERIAL: LCP BLACK, UL94 V0
 - N = NUMBER OF POSITION PER HOUSING.
 - HOUSING TO BE USED WITH CRIMP CONTACTS 2316113 (AWG 28-24/0.08-0.22 mm²) AND 2316114 (AWG 30-28/0.05-0.08 mm²)
 - PACKAGING : BULK (BOX)

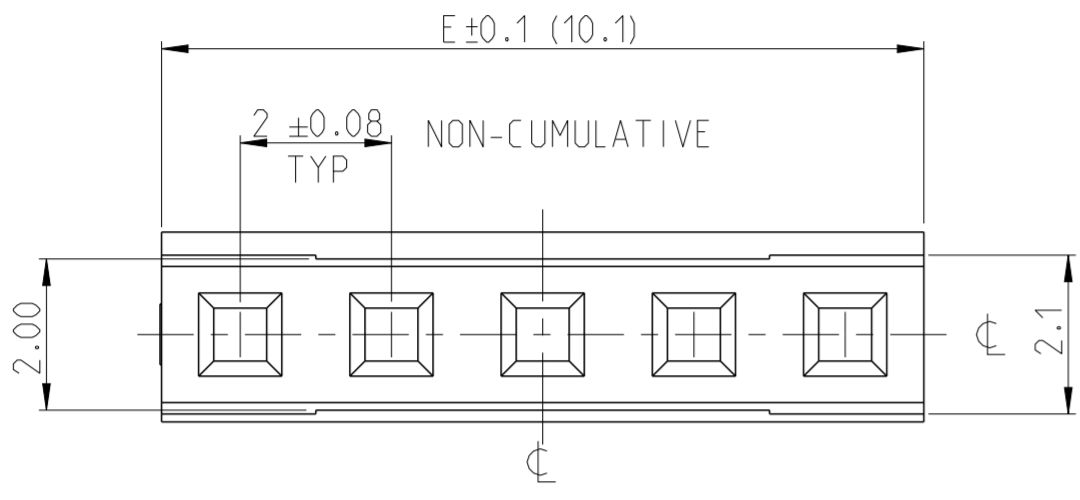
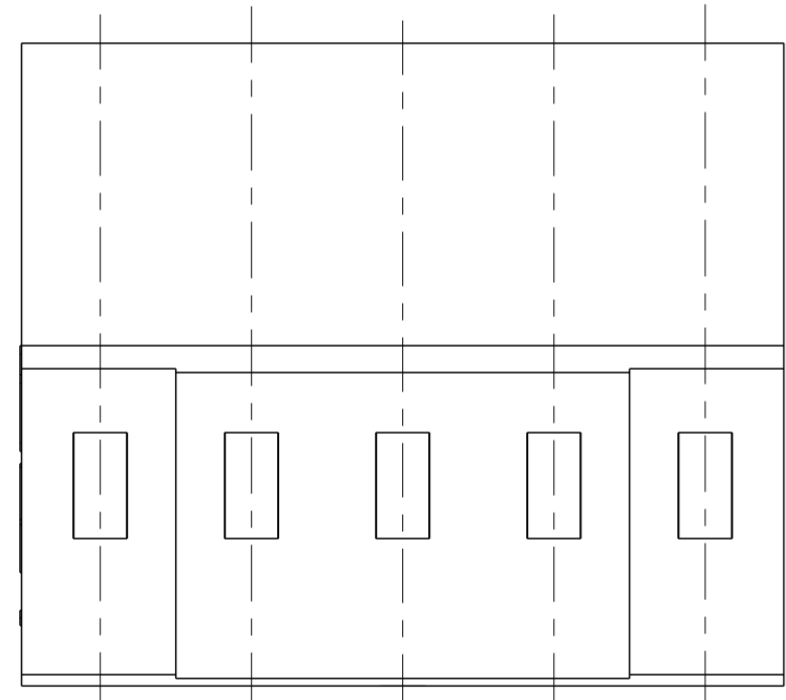

CENTERLINE FOR ODD AND EVEN POSITION HOUSINGS

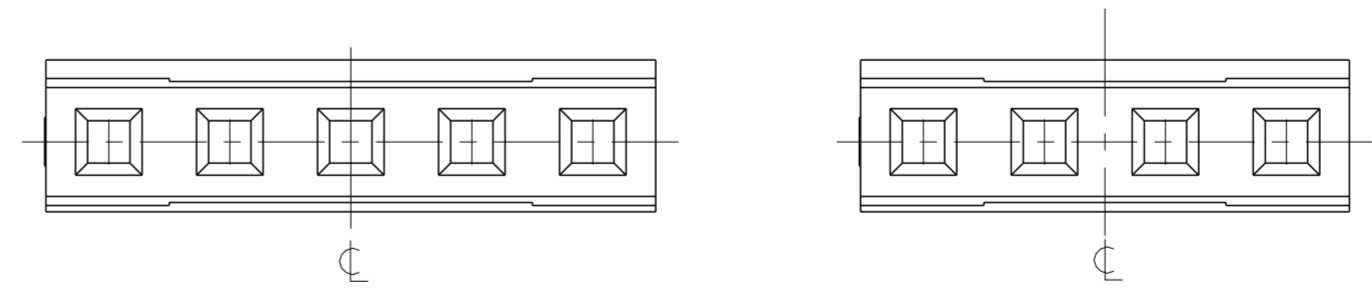

SINGLE ROW HOUSING
 PLAIN VERSION
 -5 AS SHOWN
 5:1

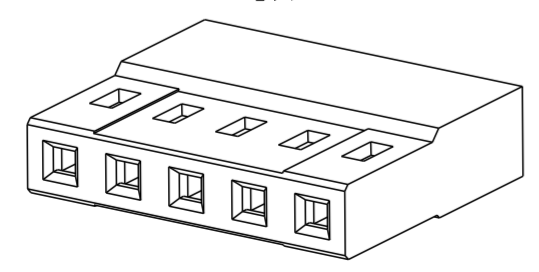

| BOX PACKAGING | | |
|---------------|---------|----|
| 2-2316102-5 | 50.1 | 25 |
| 2-2316102-4 | 48.1 | 24 |
| 2-2316102-3 | 46.1 | 23 |
| 2-2316102-2 | 44.1 | 22 |
| 2-2316102-1 | 42.1 | 21 |
| 2-2316102-0 | 40.1 | 20 |
| 1-2316102-9 | 38.1 | 19 |
| 1-2316102-8 | 36.1 | 18 |
| 1-2316102-7 | 34.1 | 17 |
| 1-2316102-6 | 32.1 | 16 |
| 1-2316102-5 | 30.1 | 15 |
| 1-2316102-4 | 28.1 | 14 |
| 1-2316102-3 | 26.1 | 13 |
| 1-2316102-2 | 24.1 | 12 |
| 1-2316102-1 | 22.1 | 11 |
| 1-2316102-0 | 20.1 | 10 |
| 2316102-9 | 18.1 | 9 |
| 2316102-8 | 16.1 | 8 |
| 2316102-7 | 14.1 | 7 |
| 2316102-6 | 12.1 | 6 |
| 2316102-5 | 10.1 | 5 |
| 2316102-4 | 8.1 | 4 |
| 2316102-3 | 6.1 | 3 |
| 2316102-2 | 4.1 | 2 |
| PART NO. | DIM "E" | N |

| | | | | |
|--|--|-----------------------------------|--|--|
| THIS DRAWING IS A CONTROLLED DOCUMENT. | | DWN 29OCT2017 RAKSHITH R NAYAK | TE Connectivity | |
| DIMENSIONS: mm | | CHK 29OCT2017 RAKSHITH R NAYAK | | |
| TOLERANCES UNLESS OTHERWISE SPECIFIED: | | APVD 11DEC2017 PRASHANTH S | NAME AMPMODU 2mm RECEPTACLE, WTB HOUSING, CRIMP, SR, PLAIN | |
| 0 PLC ± | | PRODUCT SPEC 108-64040-1 | SIZE CAGE CODE DRAWING NO RESTRICTED TO | |
| 1 PLC ±0.15 | | APPLICATION SPEC 114-32173 | A2100779 C-2316102 | |
| 2 PLC ±0.10 | | WEIGHT - | SCALE 10:1 SHEET 1 OF 1 REV A | |
| 3 PLC ± | | CUSTOMER DRAWING | | |
| 4 PLC ± | | | | |
| ANGLES ±2° | | | | |
| FINISH - | | | | |
| MATERIAL SEE NOTE 1 | | | | |

X-ON Electronics

Largest Supplier of Electrical and Electronic Components

Click to view similar products for [Headers & Wire Housings](#) category:

Click to view products by [TE Connectivity](#) manufacturer:

Other Similar products are found below :

[892-18-020-10-001101](#) [58102-G61-06LF](#) [582553-1](#) [0009485154](#) [009176003701906](#) [0050291907](#) [LY20-4P-DT1-P1E-BR](#) [02.125.8002.8](#)
[609-3404](#) [61062-3](#) [61082-181009](#) [622-3653LF](#) [63453-116](#) [636-1030](#) [636-1427](#) [636-3427](#) [636-4007](#) [641938-9](#) [641991-4](#) [644827-2](#) [65817-](#)
[010LF](#) [65817-015LF](#) [65863-015LF](#) [66207-023LF](#) [67095-007LF](#) [67601157](#) [68645-018](#) [68648-049](#) [70.362.1628.0](#) [70-4210](#) [70-4226B](#) [70-](#)
[4853B](#) [707-5020](#) [707-5028](#) [71.350.2428.0](#) [71918-208LF](#) [71961-016LF](#) [733-134](#) [733-162](#) [754199-000](#) [760-3052](#) [787-8014-00](#) [79531-3000](#)
[FCN-360C032-B](#) [FCN-367T-T012/H](#) [FCN-723D010/2](#) [80.063.4001.1](#) [800-90-001-10-001000](#) [800-90-010-10-002000](#) [801-43-002-10-013000](#)