

REVISIONS					
P	LTN	DESCRIPTION	DATE	DMN	APVD
A		RELEASED	17MAY2019	CJV	JW
B		REVISED PER ECO-19-011736	06AUG2019	AP	JW
C		REVISED PER ECO-19-013357	29AUG2019	CJV	JW
E		REVISED PER ECO-20-014352	12OCT2020	TX	DZ

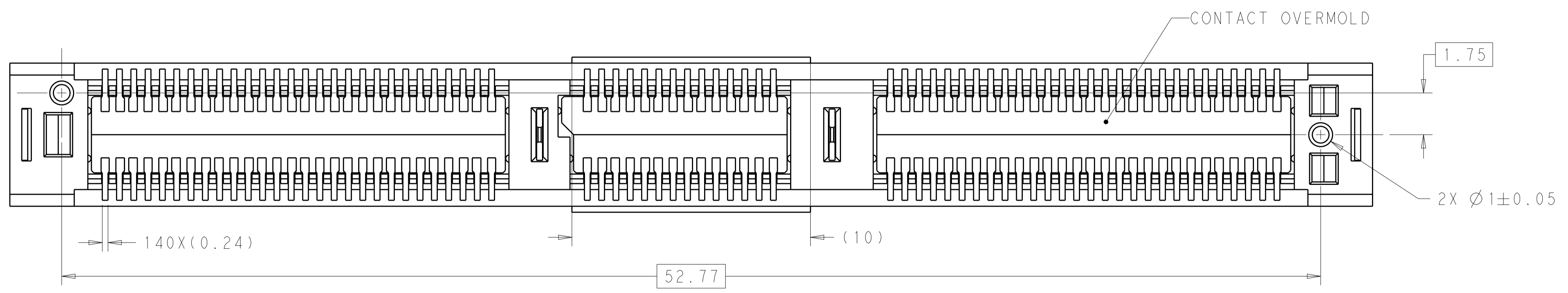

- 1 HOUSING AND CONTACT OVERMOLDS - LCP, UL94-V0. BLACK. CONTACTS AND HOLD DOWNS - COPPER ALLOY. PICK AND PLACE TAPE - POLYIMIDE FILM.
- 2 CONTACTS - GOLD PLATE ON MATING SURFACES, TIN PLATE ON SOLDER FEET. HOLD DOWNS - TIN PLATE.
- 3 DATUMS AND BASIC DIMENSIONS ESTABLISHED BY CUSTOMER.
4. MINIMUM HOST PCB THICKNESS: 1.5.
- 5 SEE MSA SPECIFICATION FOR ADDITIONAL PADDLE CARD LAYOUTS COMPATIBLE WITH THIS RECEPTACLE AND FOR OPTIONAL SPLIT CONTACT PAD LAYOUTS FOR THE PADDLE CARD. SPECIFICATION PINOUT MAY ALSO DESIGNATE PAD SEQUENCE DIFFERENT FROM ILLUSTRATION.
- 6 POSITIONS DESIGNATED AS "SIGNAL" ARE REQUIRED LOCATIONS FOR HIGH SPEED DIFFERENTIAL PAIR SIGNALING. THESE LOCATIONS MAY ALSO BE USED FOR SUPPORTING SIDEBAND SIGNALS OR OTHER UTILITY PURPOSES. POSITIONS DESIGNATED AS "GROUND" ARE REQUIRED WHEN SUPPORTING HIGH SPEED DIFFERENTIAL SIGNALS. THESE LOCATIONS MAY ALSO BE USED FOR SIDEBAND SIGNALS OR OTHER UTILITY PURPOSES.
- 7 COMPONENT AND TRACE KEEP OUT AREA. EACH EDGE 0.15 MIN FROM EDGE OF HOLE.
- 8 TAPE AND REEL PACKAGED FOR PICK AND PLACE SMT PROCESSING, SEE FIGURE 1. POCKET TAPE WIDTH = 72.
- 9 MATES WITH BOARDS DESIGNED TO THE SFF-TA-1002 SPECIFICATION.

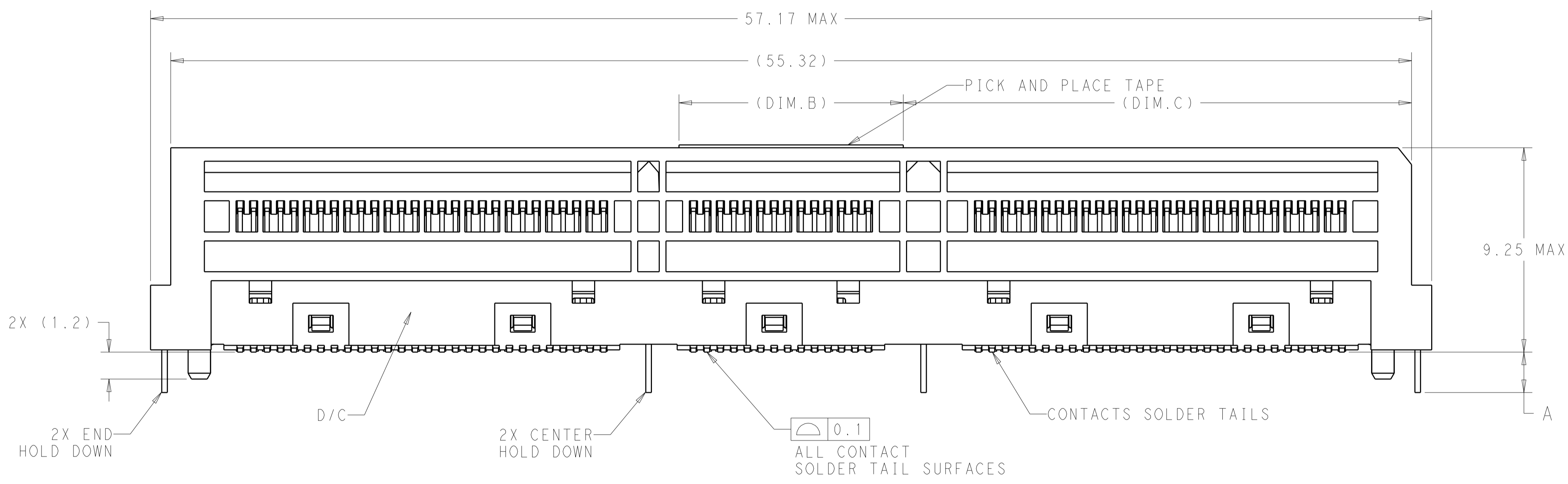
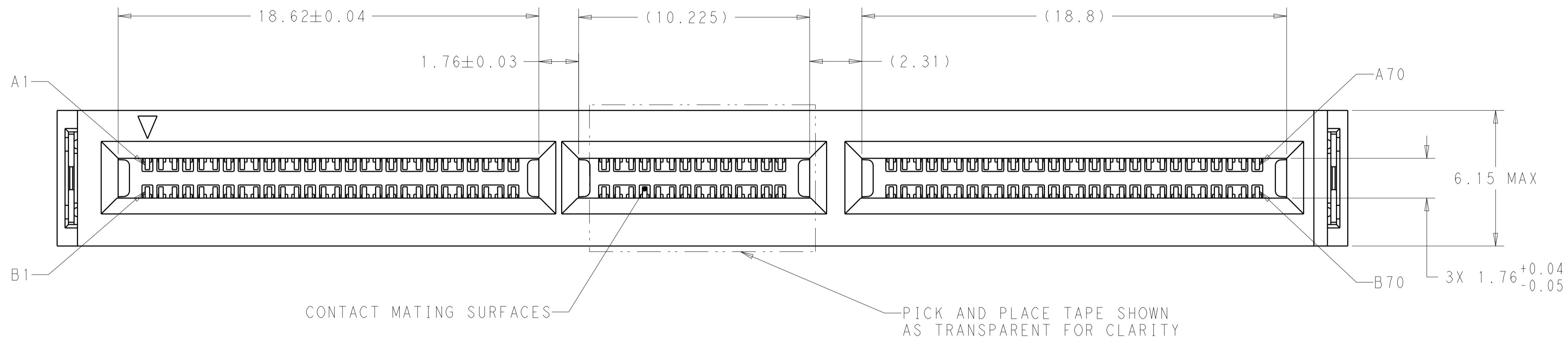
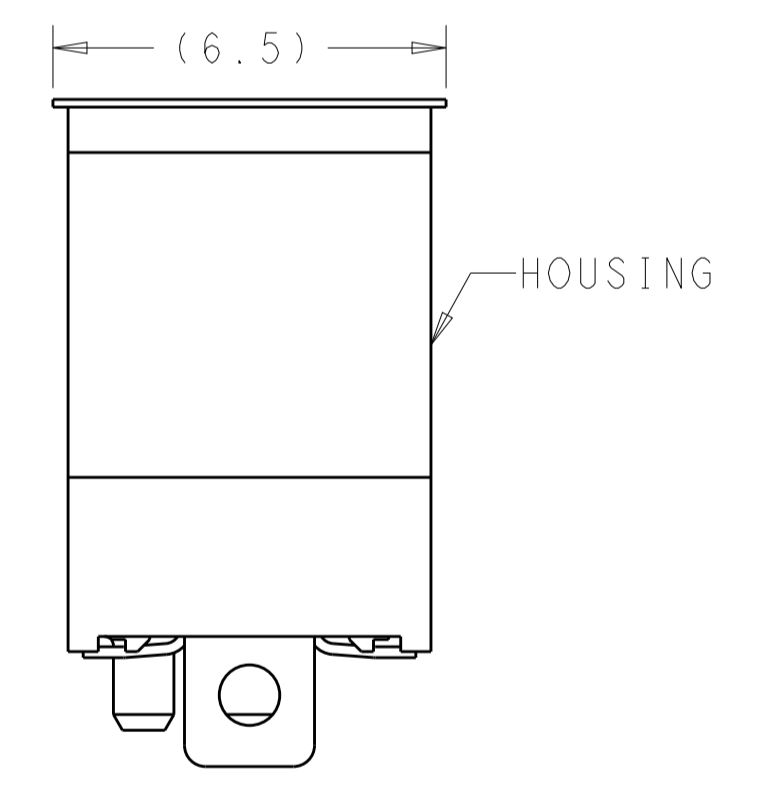

SEE SHEET 4 FOR PART TABLE

THIS DRAWING IS A CONTROLLED DOCUMENT.		DMN C. VALENTINE 16JAN2018	TE Connectivity
DIMENSIONS: mm		CHK D. HARMON 16JAN2018	
TOLERANCES UNLESS OTHERWISE SPECIFIED:		APVD D. HARMON 16JAN2018	NAME RECEPTACLE ASSEMBLY, VERTICAL, 140 POSITION, SLIVER 2.0
0 PLC ±	1 PLC ±0.25	PRODUCT SPEC 108-130021	SIZE CAGE CODE DRAWING NO
2 PLC ±0.20	3 PLC ±	APPLICATION SPEC 114-130008	RESTRICTED TO
4 PLC ±	ANGLES ±	WEIGHT	A100779C=2327677
MATERIAL	FINISH	CUSTOMER DRAWING	SCALE 8:1 SHEET 1 OF 4 REV E

REVISIONS				
P.	LTN.	DESCRIPTION	DATE	APVD.
-	-	SEE SHEET 1	-	-

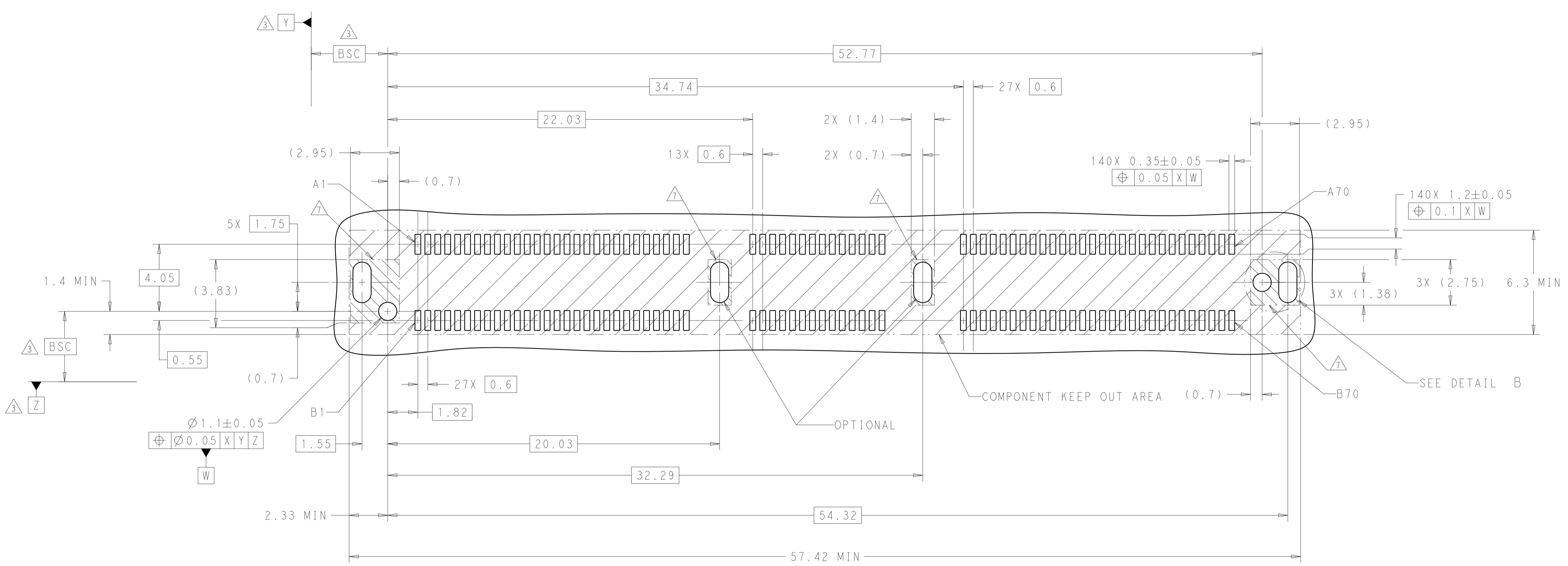

RECOMMENDED PCB LAYOUT  
AND KEEP OUT AREA

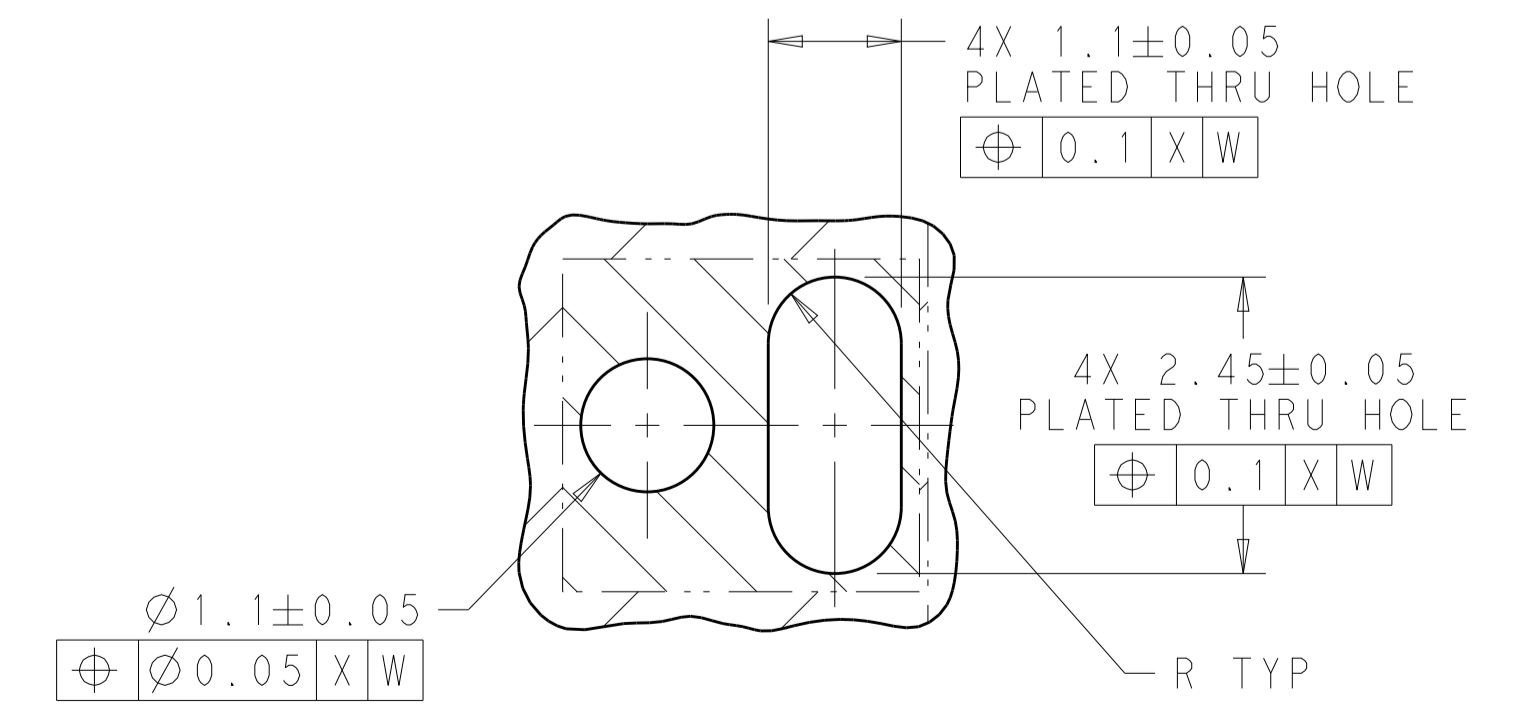
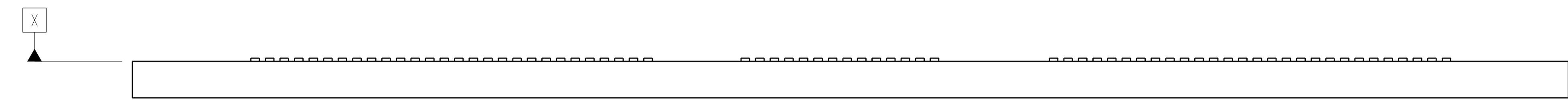

DETAIL B  
SCALE 16:1

THIS DRAWING IS A CONTROLLED DOCUMENT.		DWN C. VALENTINE 16JAN2018 CHK D. HARMON 16JAN2018 APVD D. HARMON 16JAN2018	TE Connectivity
DIMENSIONS: mm TOLERANCES UNLESS OTHERWISE SPECIFIED: 0 PLC ±0.25 1 PLC ±0.20 2 PLC ±0.20 3 PLC ±0.20 4 PLC ±0.20 ANGLES ±0.25		NAME RECEPTACLE ASSEMBLY, VERTICAL, 140 POSITION, SLIVER 2.0 PRODUCT SPEC 108-130021 APPLICATION SPEC 114-130008 WEIGHT - CUSTOMER DRAWING	
MATERIAL 1 FINISH 2		SIZE CAGE CODE DRAWING NO A100779C=2327677	RESTRICTED TO SCALE 8:1 SHEET 2 OF 4 REV E

REVISIONS				
P.	LTN.	DESCRIPTION	DATE	APVD.
-	-	SEE SHEET 1	-	-

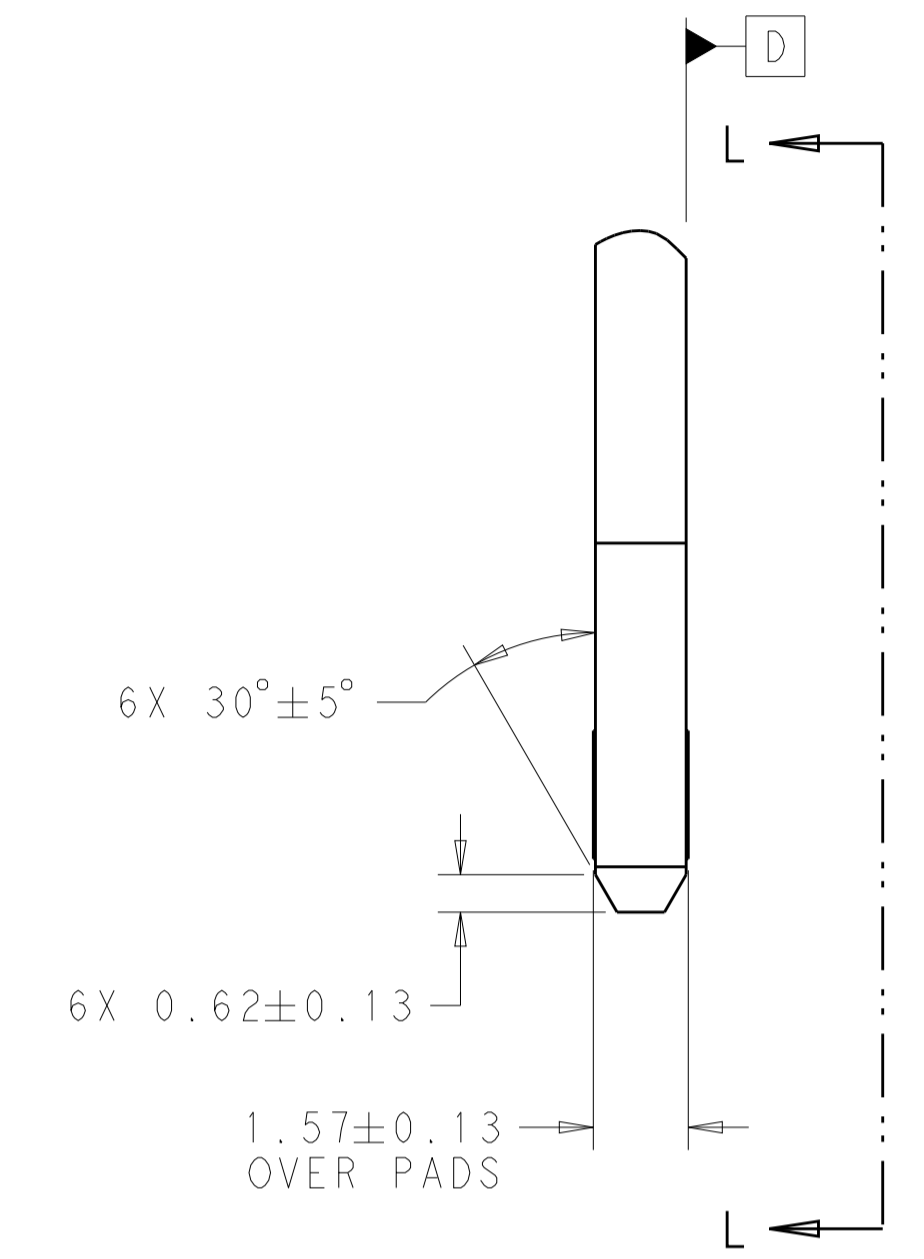
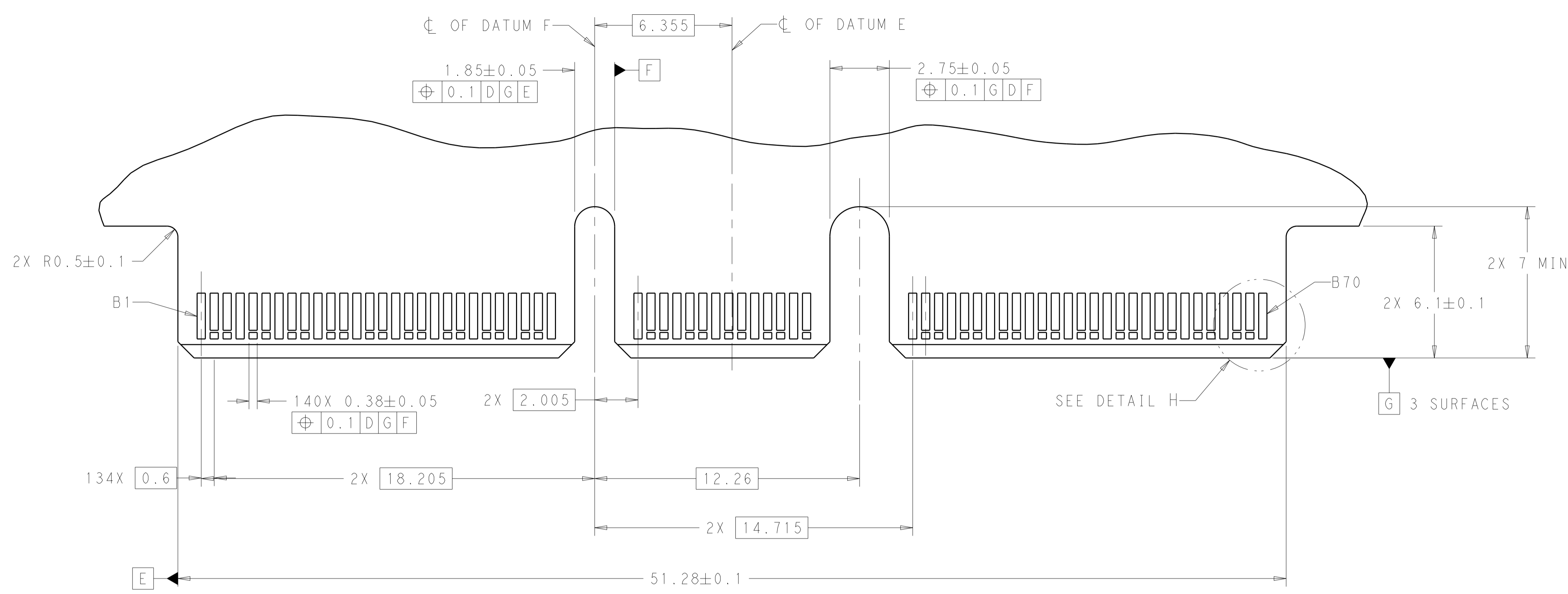

RECOMMENDED PCB OUTLINE DIMENSIONS.  
TOLERANCE VALUES ARE CRITICAL. PLEASE BE SURE TO DESIGNATE TOLERANCES TO PCB SUPPLIER TO ENSURE OPTIMIZED FUNCTIONALITY.

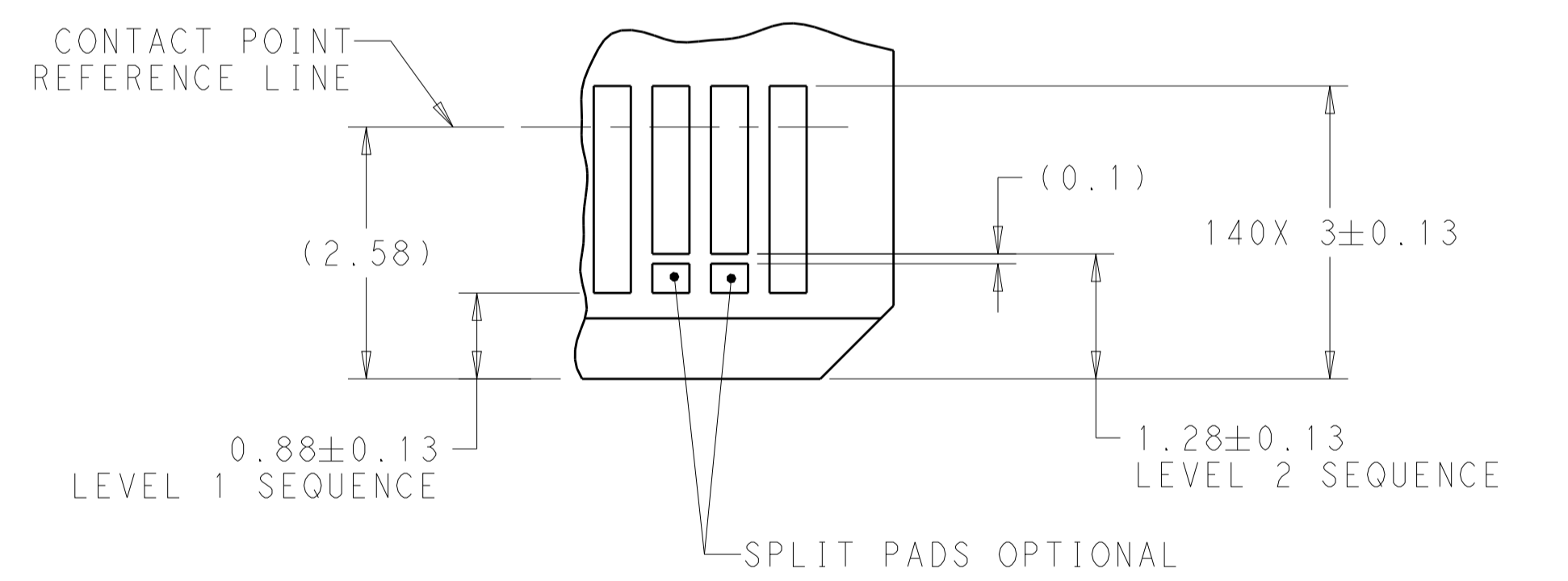
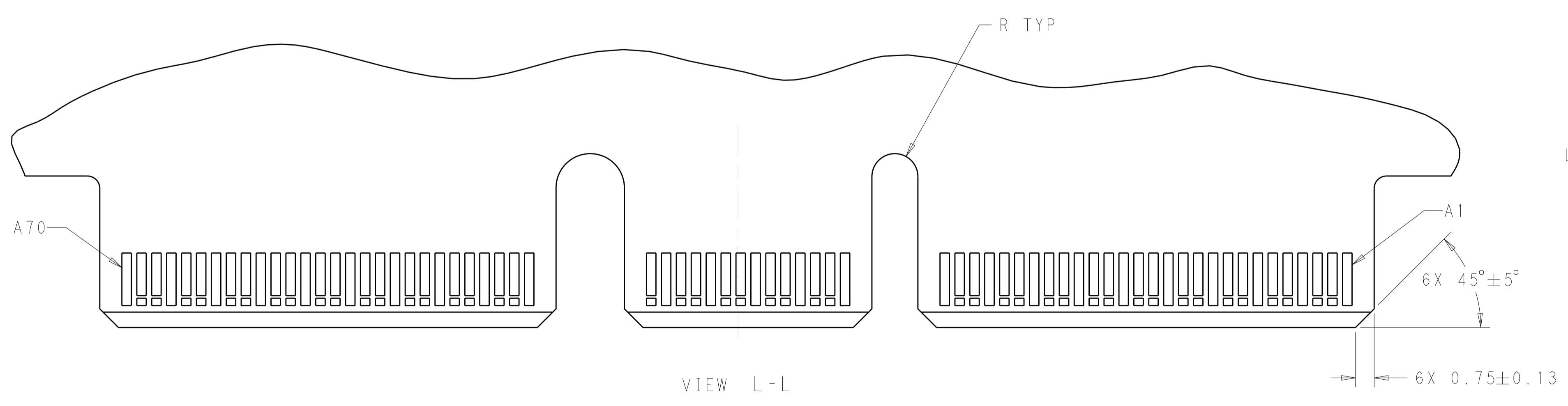

DETAIL H  
SCALE 16:1

THIS DRAWING IS A CONTROLLED DOCUMENT.		DWN: C. VALENTINE 16JAN2018 CHK: D. HARMON 16JAN2018 APVD: D. HARMON 16JAN2018	TE Connectivity
DIMENSIONS: mm	TOLERANCES UNLESS OTHERWISE SPECIFIED: 0 PLC ± 1 PLC ±0.25 2 PLC ±0.20 3 PLC ± 4 PLC ± ANGLES ± FINISH ±	NAME: RECEPTACLE ASSEMBLY, VERTICAL, 140 POSITION, SLIVER 2.0 PRODUCT SPEC: 108-130021 APPLICATION SPEC: 114-130008 WEIGHT: - CUSTOMER DRAWING	

REVISIONS				
P.	LTN	DESCRIPTION	DATE	APVD
-	-	SEE SHEET 1	-	-

TABLE 1: CONNECTOR CONTACT IDENTIFICATION  $\triangle$   $\triangle$

CONTACT NUMBER	SIDE A	SIDE B	CONTACT NUMBER	SIDE A	SIDE B
1	GROUND	GROUND	36	SIGNAL	SIGNAL
2	SIGNAL	SIGNAL	37	SIGNAL	SIGNAL
3	SIGNAL	SIGNAL	38	GROUND	GROUND
4	GROUND	GROUND	39	SIGNAL	SIGNAL
5	SIGNAL	SIGNAL	40	SIGNAL	SIGNAL
6	SIGNAL	SIGNAL	41	GROUND	GROUND
7	GROUND	GROUND	42	GROUND	GROUND
8	SIGNAL	SIGNAL	43	GROUND	GROUND
9	SIGNAL	SIGNAL	44	SIGNAL	SIGNAL
10	GROUND	GROUND	45	SIGNAL	SIGNAL
11	SIGNAL	SIGNAL	46	GROUND	GROUND
12	SIGNAL	SIGNAL	47	SIGNAL	SIGNAL
13	GROUND	GROUND	48	SIGNAL	SIGNAL
14	SIGNAL	SIGNAL	49	GROUND	GROUND
15	SIGNAL	SIGNAL	50	SIGNAL	SIGNAL
16	GROUND	GROUND	51	SIGNAL	SIGNAL
17	SIGNAL	SIGNAL	52	GROUND	GROUND
18	SIGNAL	SIGNAL	53	SIGNAL	SIGNAL
19	GROUND	GROUND	54	SIGNAL	SIGNAL
20	SIGNAL	SIGNAL	55	GROUND	GROUND
21	SIGNAL	SIGNAL	56	SIGNAL	SIGNAL
22	GROUND	GROUND	57	SIGNAL	SIGNAL
23	SIGNAL	SIGNAL	58	GROUND	GROUND
24	SIGNAL	SIGNAL	59	SIGNAL	SIGNAL
25	GROUND	GROUND	60	SIGNAL	SIGNAL
26	SIGNAL	SIGNAL	61	GROUND	GROUND
27	SIGNAL	SIGNAL	62	SIGNAL	SIGNAL
28	GROUND	GROUND	63	SIGNAL	SIGNAL
29	GROUND	GROUND	64	GROUND	GROUND
30	SIGNAL	SIGNAL	65	SIGNAL	SIGNAL
31	SIGNAL	SIGNAL	66	SIGNAL	SIGNAL
32	GROUND	GROUND	67	GROUND	GROUND
33	SIGNAL	SIGNAL	68	SIGNAL	SIGNAL
34	SIGNAL	SIGNAL	69	SIGNAL	SIGNAL
35	GROUND	GROUND	70	GROUND	GROUND

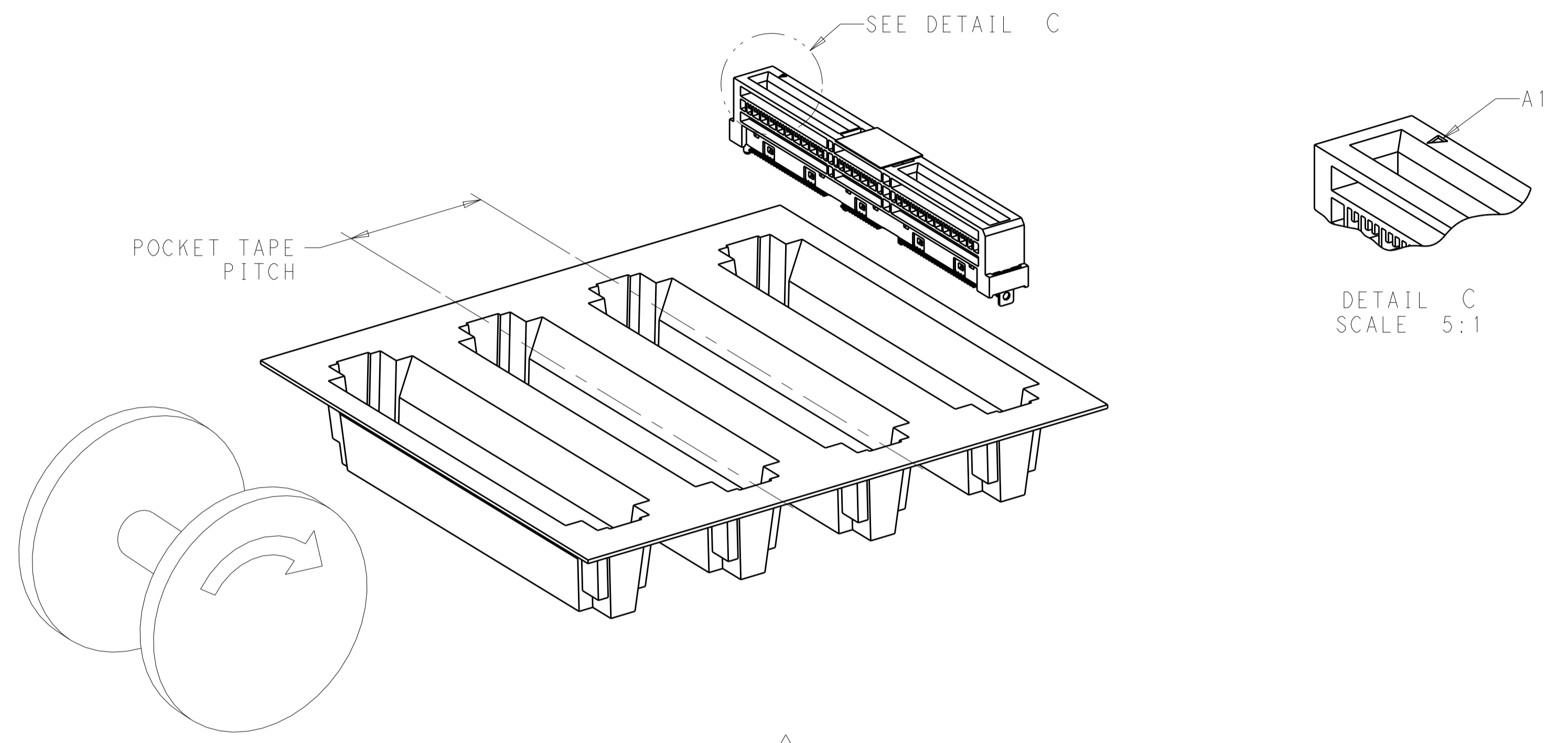

**FIGURE 1**  $\triangle$   
 DIRECTION OFF TOP OF REEL  
 FOR USER UNREELING  
 SHOWN AS 2327677-1 THRU 2-2327677-3  
 SCALE 2:1

7.66	40	1.8±0.1	ALL	0.76µm Au	20	350	YES	200	5-2327677-3
22.66	10	3±0.1	ALL	0.76µm Au	20	250	YES	200	2-2327677-3
N/A	N/A	1.2±0.1	ENDS	0.76µm Au	24	250	NO	200	1-2327677-9
				0.38µm Au				100	1-2327677-8
N/A	N/A	1.8±0.1	ENDS	FLASH Au/PdNi	24	250	NO	50	1-2327677-7
				0.76µm Au				200	1-2327677-6
				0.38µm Au				100	1-2327677-5
N/A	N/A	1.8±0.1	ALL	FLASH Au/PdNi	24	250	NO	50	1-2327677-4
				0.76µm Au				200	1-2327677-3
				0.38µm Au				100	1-2327677-2
22.66	10	1.8±0.1	ENDS	0.76µm Au	20	350	YES	200	2327677-9
				0.38µm Au				100	2327677-8
				FLASH Au/PdNi				50	2327677-7
22.66	10	1.8±0.1	ENDS	0.76µm Au	20	350	YES	200	2327677-6
				0.38µm Au				100	2327677-5
				FLASH Au/PdNi				50	2327677-4
22.66	10	1.8±0.1	ALL	0.76µm Au	20	350	YES	200	2327677-3
				0.38µm Au				100	2327677-2
				FLASH Au/PdNi				50	2327677-1
DIM.C	DIM.B	A	HOLD DOWNS	PLATING	POCKET TAPE PITCH	REEL QUANTITY	PICK AND PLACE TAPE	MATING CYCLES	PART NUMBER

THIS DRAWING IS A CONTROLLED DOCUMENT.

DIMENSIONS: mm  
 TOLERANCES UNLESS OTHERWISE SPECIFIED:  
 0 PLC ±0.25  
 1 PLC ±0.20  
 2 PLC ±0.20  
 3 PLC ±0.20  
 4 PLC ±0.20  
 ANGLES ±0.5°  
 MATERIAL FINISH

DWN: C. VALENTINE 16 JAN 2018  
 CHK: D. HARMON 16 JAN 2018  
 APVD: D. HARMON 16 JAN 2018

NAME: RECEPTACLE ASSEMBLY, VERTICAL, 140 POSITION, SLIVER 2.0  
 PRODUCT SPEC: 108-130021  
 APPLICATION SPEC: 114-130008  
 WEIGHT: -  
 CUSTOMER DRAWING

SCALE: 8:1  
 SHEET: 4 OF 4  
 REV: E

**STE** TE Connectivity

## X-ON Electronics

Largest Supplier of Electrical and Electronic Components

*Click to view similar products for [Standard Card Edge Connectors](#) category:*

*Click to view products by [TE Connectivity](#) manufacturer:*

Other Similar products are found below :

[CR7E-30DB-3.96E\(72\)](#) [6364499-1](#) [6565204-6](#) [PKC-156](#) [1437274-4](#) [147889-1](#) [1489165-4](#) [EBT15622B2X](#) [1-582587-1](#) [284-0102-12100](#)  
[286-0052-12101A](#) [306022901000000](#) [307-012-502-202](#) [307-056-520-300](#) [2129318-1](#) [245-062-520-350](#) [287-0032-12101](#) [306-028-525-102](#)  
[307-072-526-202](#) [345-060-559-303](#) [392-008-559-201](#) [534671-1](#) [341-240-317](#) [345-044-500-300](#) [346-240-318](#) [395-100-524-300](#) [09-07-2032](#)  
[10035388-802LF](#) [10115859-011LF](#) [10122859-009LF](#) [10127905-B04B24BLF](#) [530555-1](#) [5-678046-1](#) [73726-0005](#) [66308-1](#) [1-1437275-6](#)  
[PEC-07-02-T-S-A](#) [346-014-520-801](#) [307-048-502-202](#) [CE100F22-9-C](#) [CE100F26-7-C](#) [CE100F28-3-D](#) [CE156F18-9-C](#) [CE156F22-5-D](#)  
[CE156F22-9-C](#) [CT100F22-2-D](#) [CT100F22-3-D](#) [CT100F24-2-D](#) [CT100F24-3-D](#) [CT100F24-6-C](#)