

REVISIONS				
P.	LTN	DESCRIPTION	DATE	APVD
A		RELEASED PER ECO-19-014774	26SEP2019	CJV JW

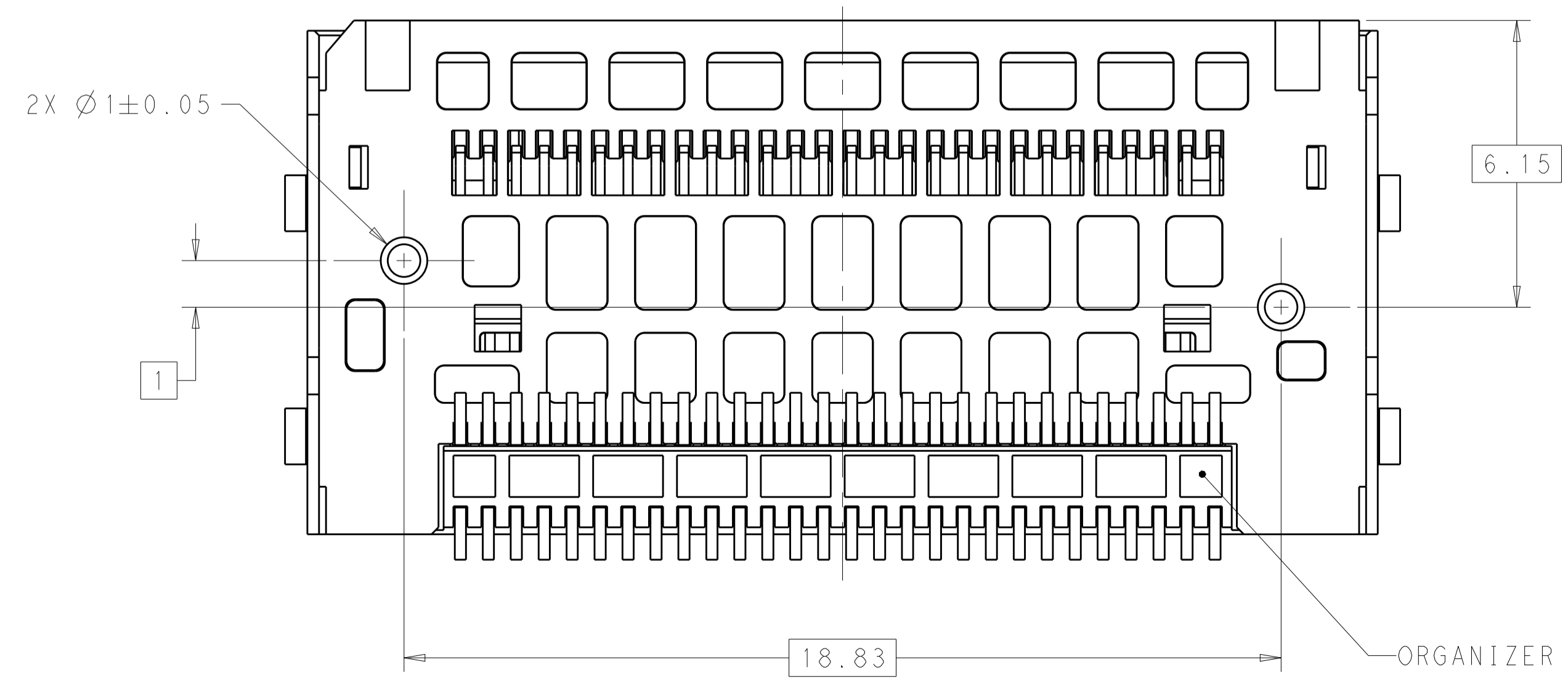

- △ HOUSING, ORGANIZER AND CONTACT OVERMOLDS - LCP, UL94V-0, BLACK. SHELL, CONTACTS AND HOLD DOWNS - COPPER ALLOY.
- △ CONTACTS - GOLD PLATE ON MATING SURFACES, TIN PLATE ON SOLDER FEET. HOLD DOWNS - TIN PLATE. SHELL - NICKEL PLATE, TIN PLATE ON HOLD DOWNS.
- △ DATUMS AND BASIC DIMENSIONS ESTABLISHED BY CUSTOMER.
- 4. MINIMUM HOST PCB THICKNESS: 1.5.
- △ SEE MSA SPECIFICATION FOR ADDITIONAL PADDLE CARD LAYOUTS COMPATIBLE WITH THIS RECEPTACLE AND FOR OPTIONAL SPLIT CONTACT PAD LAYOUTS FOR THE PADDLE CARD. SPECIFICATION PINOUT MAY ALSO DESIGNATE PAD SEQUENCE DIFFERENT FROM ILLUSTRATION.
- △ POSITIONS DESIGNATED AS "SIGNAL" ARE REQUIRED LOCATIONS FOR HIGH SPEED DIFFERENTIAL PAIR SIGNALING. THESE LOCATIONS MAY ALSO BE USED FOR SUPPORTING SIDEBAND SIGNALS OR OTHER UTILITY PURPOSES. POSITIONS DESIGNATED AS "GROUND" ARE REQUIRED WHEN SUPPORTING HIGH SPEED DIFFERENTIAL SIGNALS. THESE LOCATIONS MAY ALSO BE USED FOR SIDEBAND SIGNALS OR OTHER UTILITY PURPOSES.
- △ COMPONENT AND TRACES KEEP OUT AREA. EACH EDGE 0.15 MIN FROM EDGE OF HOLE.
- △ TAPE AND REEL PACKAGED FOR PICK AND PLACE SURFACE MOUNT PROCESSING, SEE FIGURE 1. POCKET TAPE: WIDTH = 44.

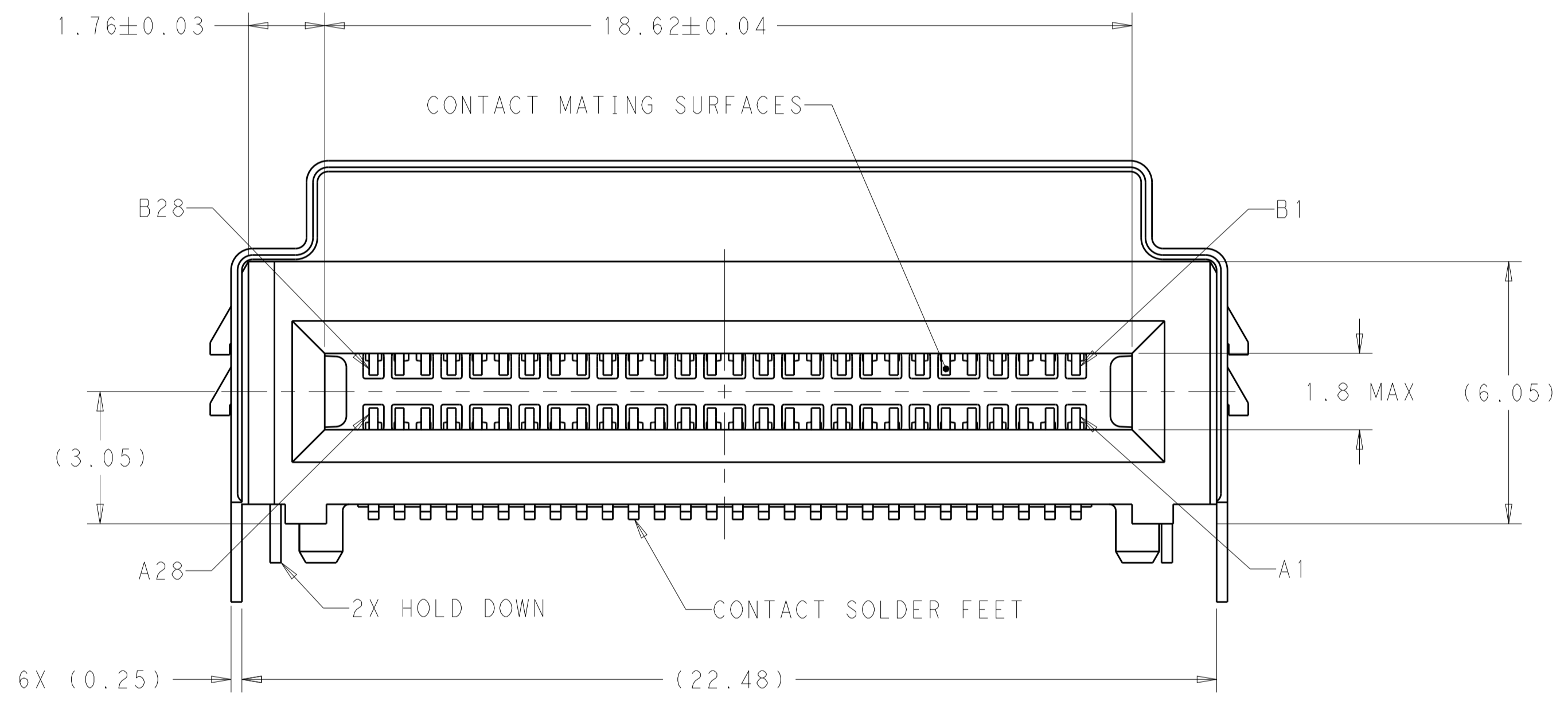
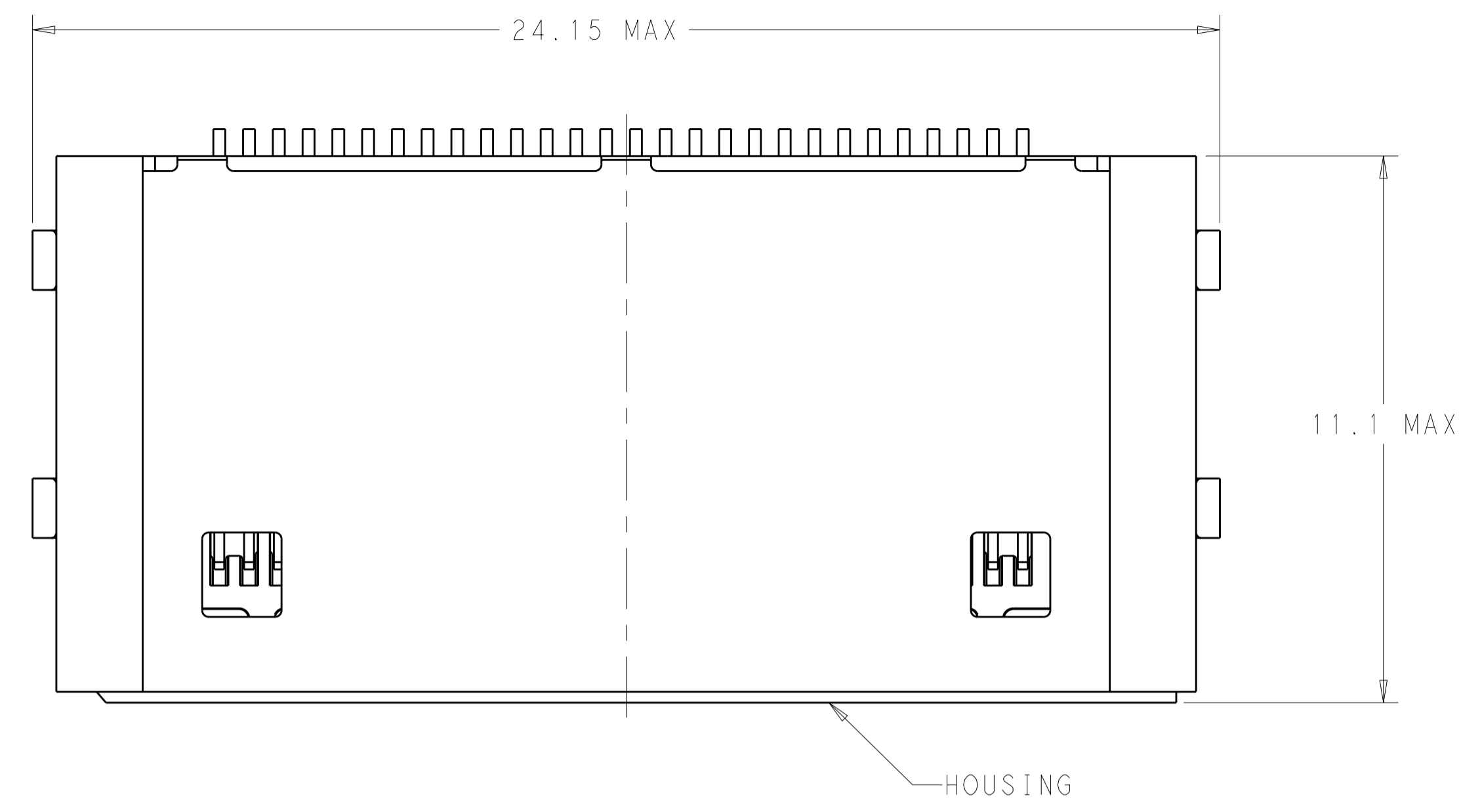
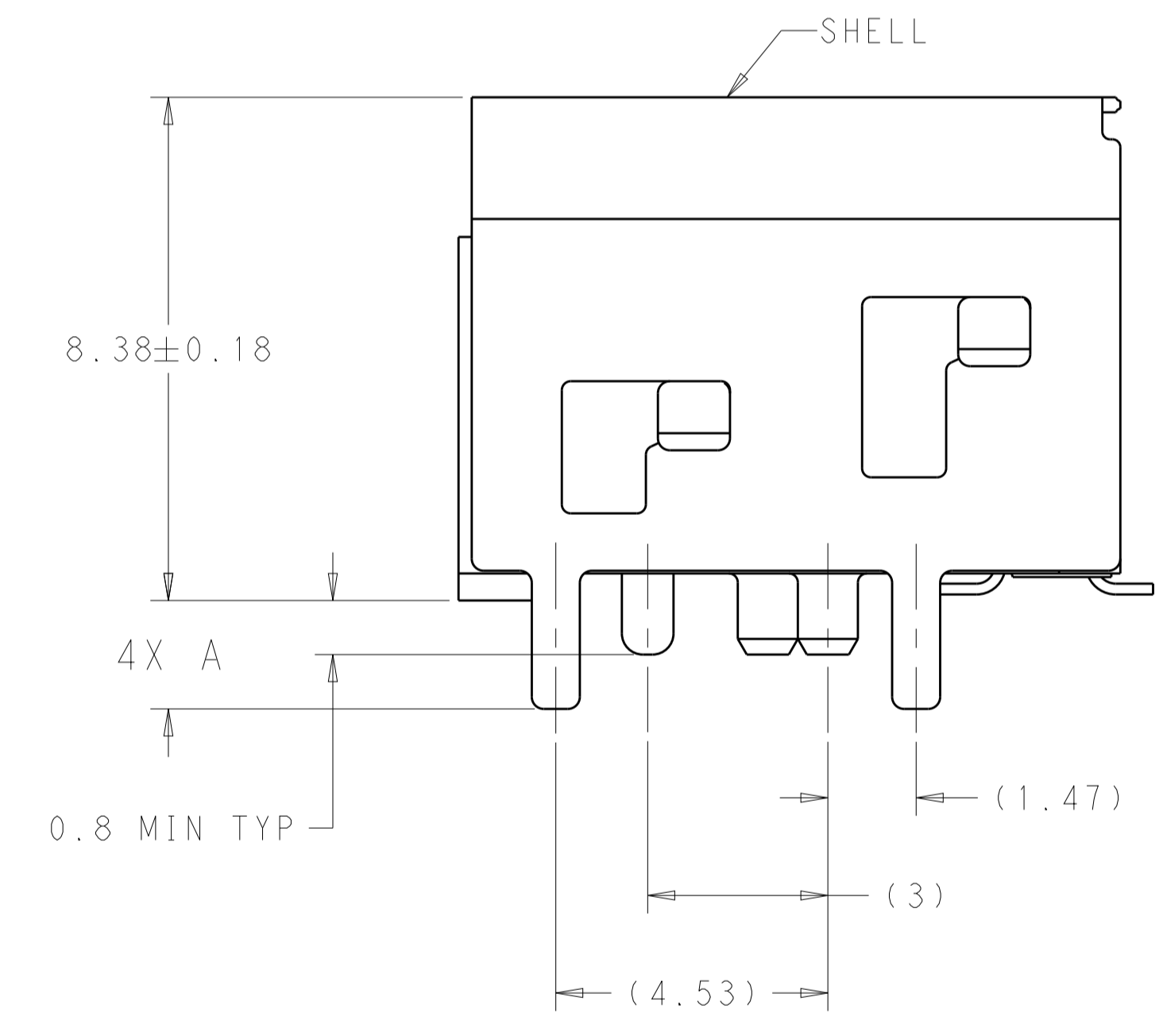

SEE SHEET 4 FOR PART TABLE

THIS DRAWING IS A CONTROLLED DOCUMENT.		OWN: B. MATTHEWS 29MAR2018	TE Connectivity
DIMENSIONS: mm		CHK: D. HARMON 29MAR2018	
TOLERANCES UNLESS OTHERWISE SPECIFIED:		APVD: D. HARMON 29MAR2018	NAME: RECEPTACLE ASSEMBLY, RIGHT ANGLE, 56 POSITION, SLIVER 2.0
0 PLC ±	1 PLC ±	PRODUCT SPEC: 108-130021	SIZE: A1
2 PLC ±	3 PLC ±	APPLICATION SPEC: 114-130015	CAGE CODE: 00779
4 PLC ±	ANGLES ±	WEIGHT: -	DRAWING NO: 2332208
MATERIAL: △	FINISH: △	CUSTOMER DRAWING	SCALE: 10:1
			SHEET 1 OF 4 REV A

REVISIONS				
REV	LTN	DESCRIPTION	DATE	APVD
-	-	SEE SHEET 1	-	-

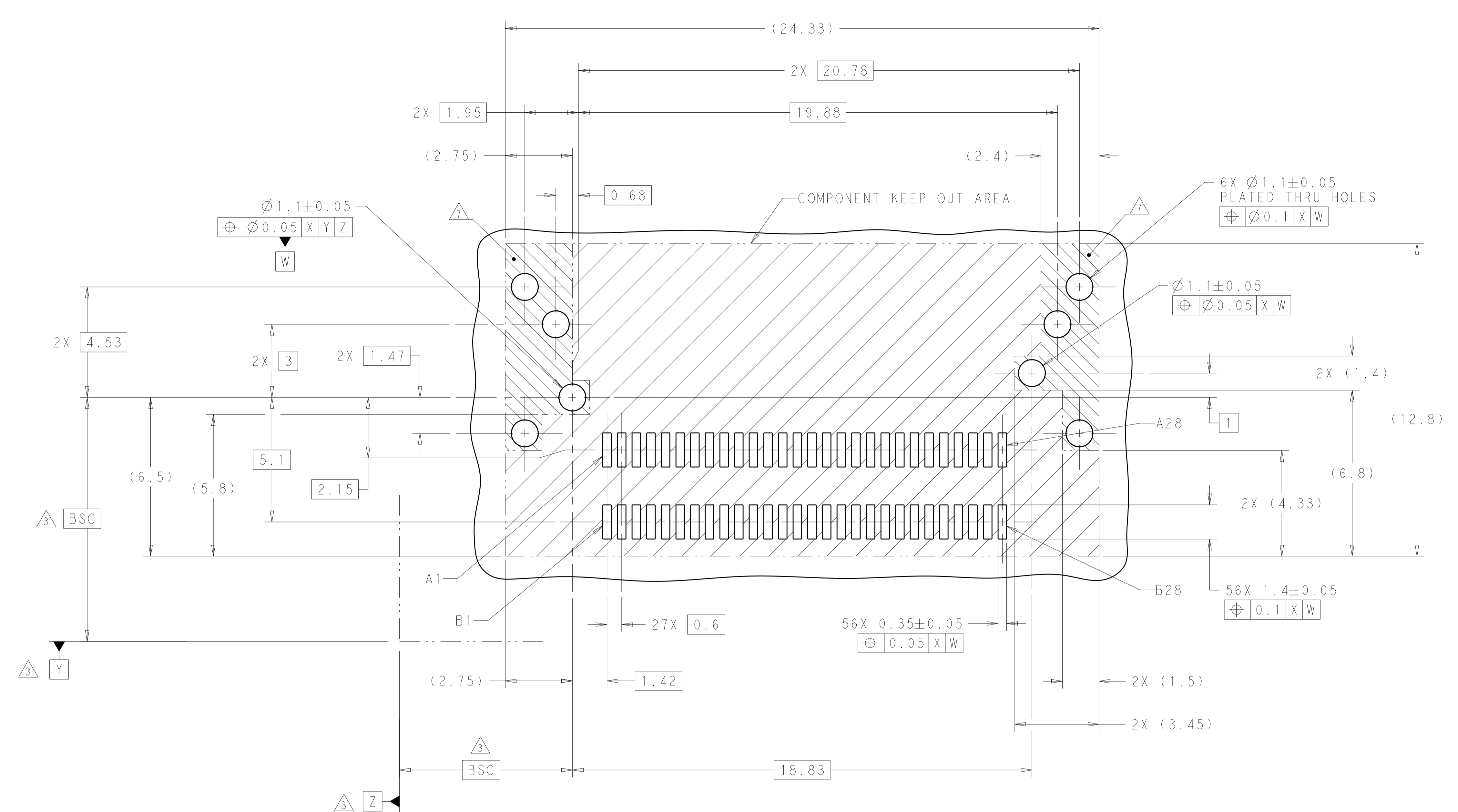

RECOMMENDED PCB LAYOUT AND KEEP OUT AREA

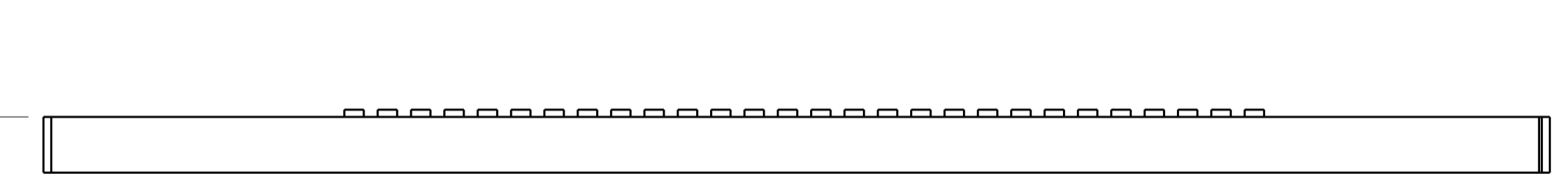

THIS DRAWING IS A CONTROLLED DOCUMENT.		DWN B. MATTHEWS 29MAR2018	STE TE Connectivity
DIMENSIONS: mm		CHK D. HARMON 29MAR2018	
TOLERANCES UNLESS OTHERWISE SPECIFIED:		APVD D. HARMON 29MAR2018	NAME RECEPTACLE ASSEMBLY, RIGHT ANGLE, 56 POSITION, SLIVER 2.0
0 PLC ±	1 PLC ±	PRODUCT SPEC	SIZE CAGE CODE DRAWING NO RESTRICTED TO
2 PLC ±	3 PLC ±	108-130021	A100779C=2332208
4 PLC ±	ANGLES ±	APPLICATION SPEC	WEIGHT
MATERIAL	FINISH	114-130015	SCALE 10:1 SHEET 2 OF 4 REV A
CUSTOMER DRAWING		114-130015	

REVISIONS				
P.	LTN.	DESCRIPTION	DATE	APVD.
-	-	SEE SHEET 1	-	-

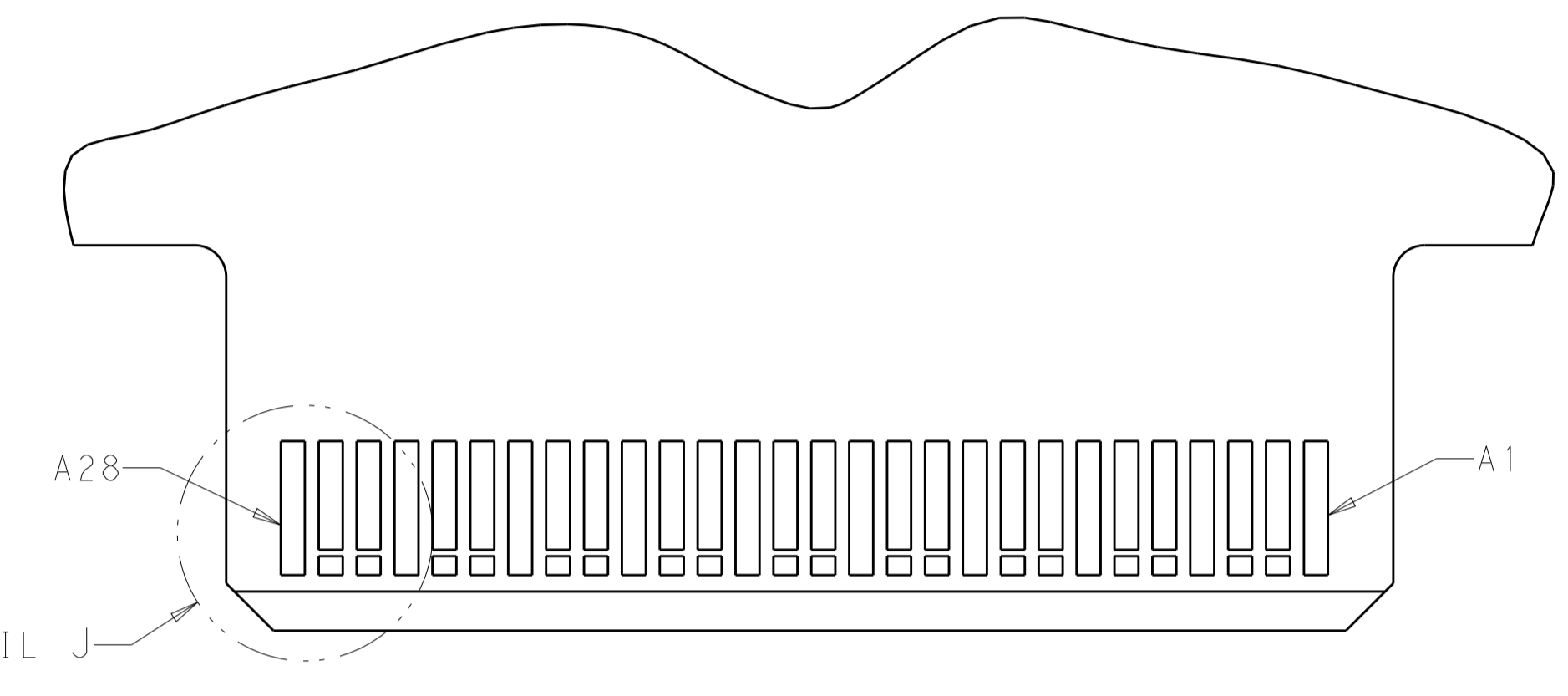
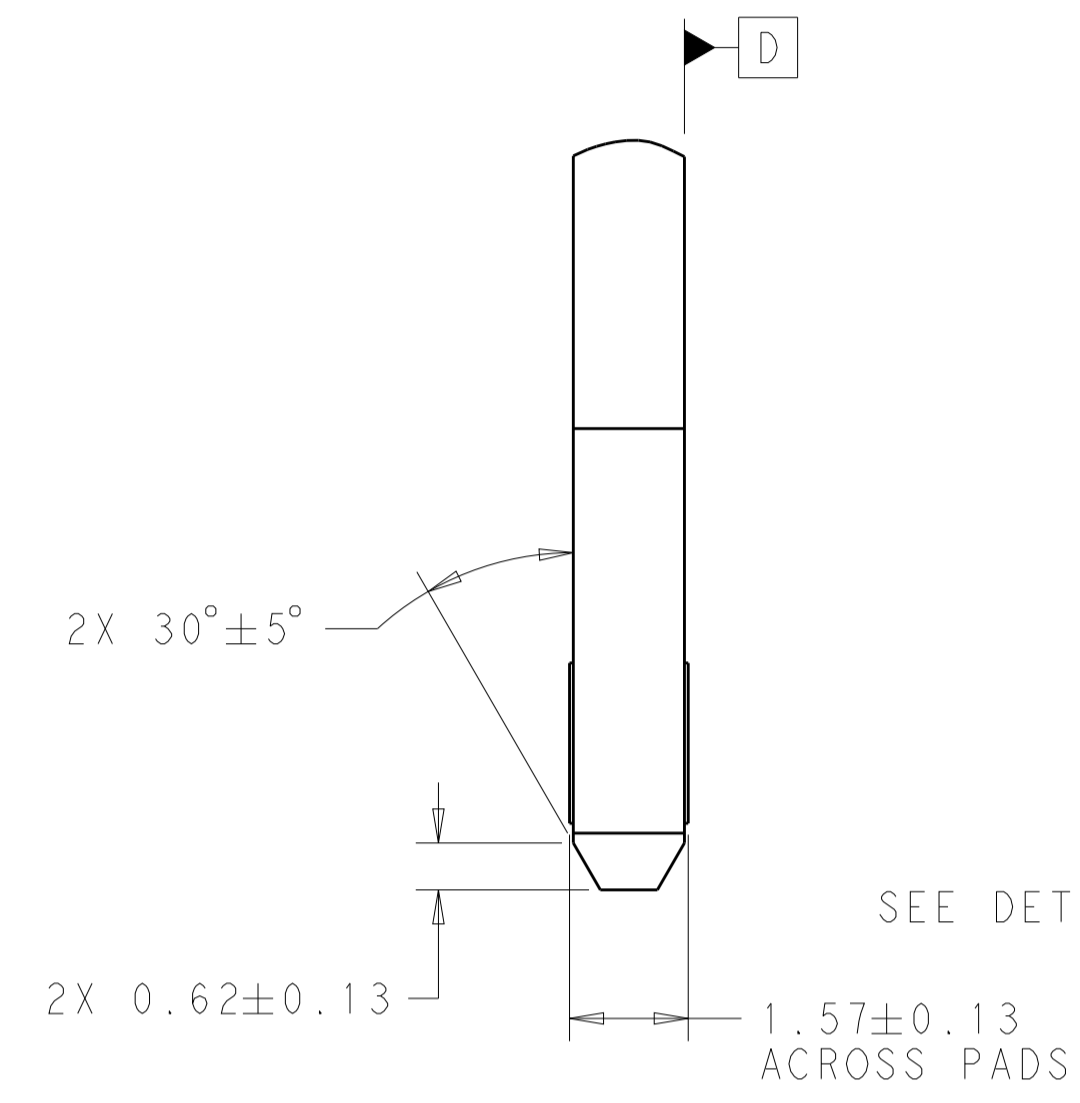
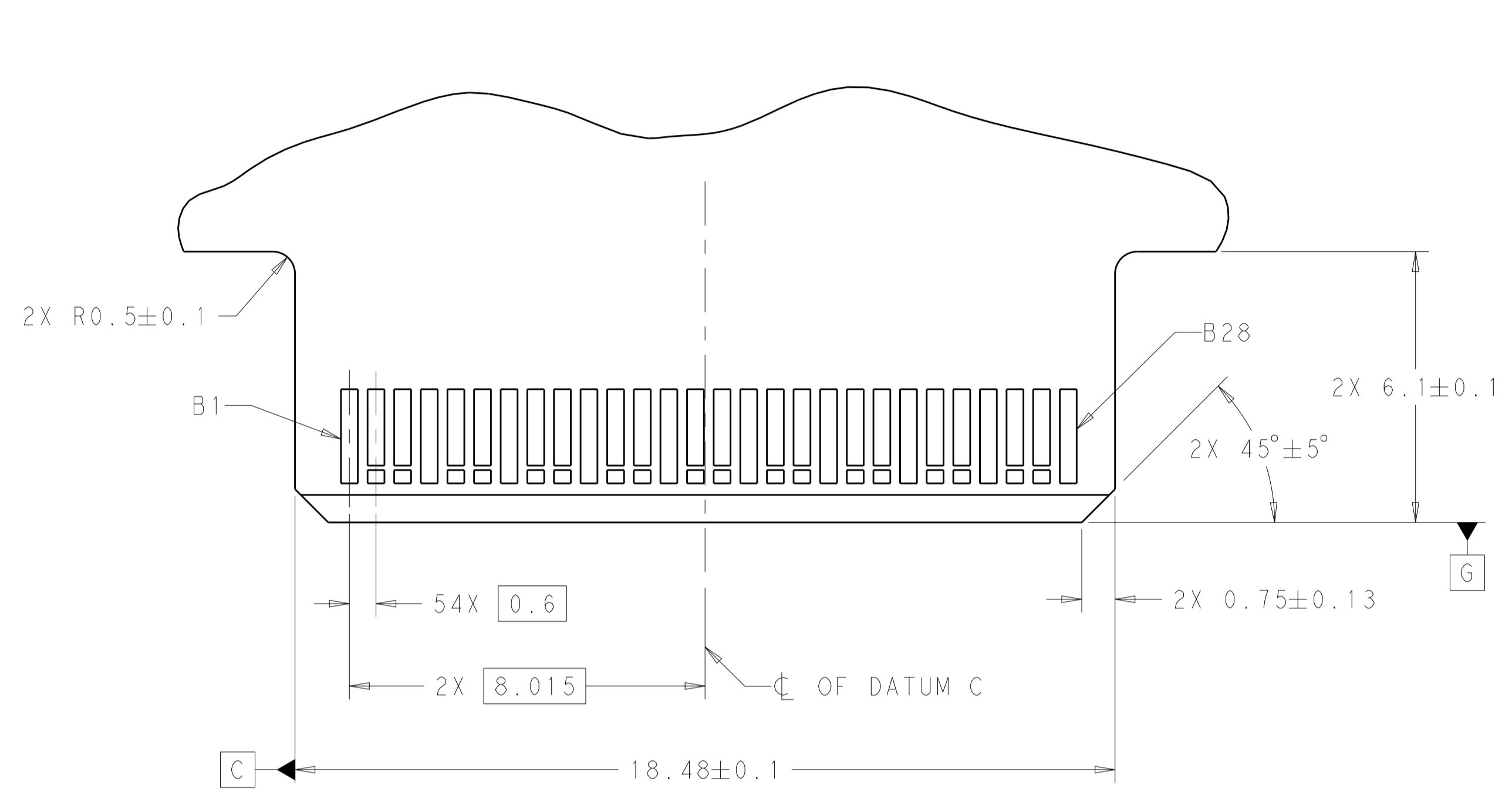

RECOMMENDED PCB OUTLINE DIMENSIONS:
 TOLERANCE VALUES ARE CRITICAL. PLEASE BE SURE TO DESIGNATE
 TOLERANCES TO PCB SUPPLIER TO ENSURE OPTIMIZED FUNCTIONALITY.

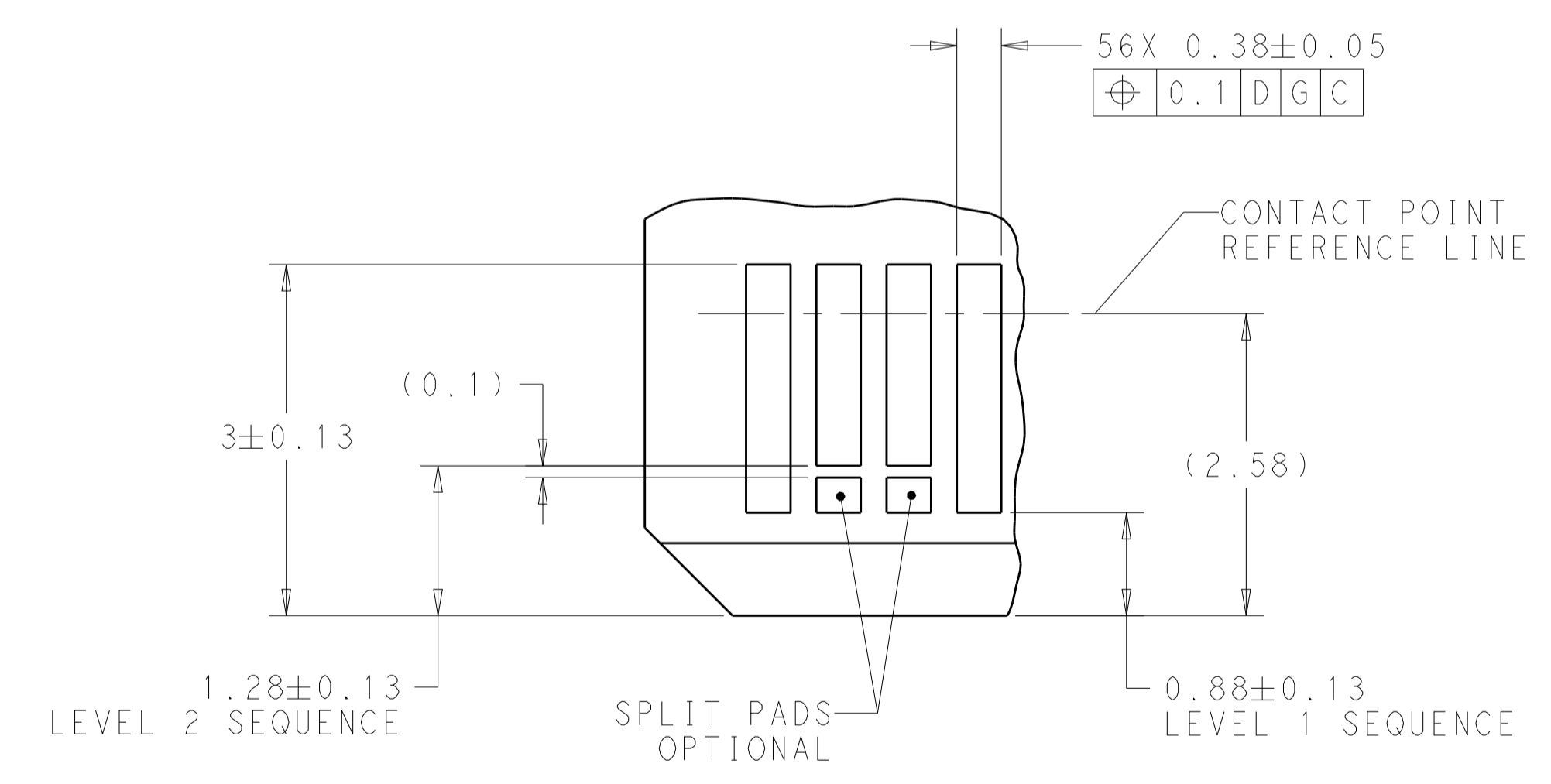

DETAIL J
 SCALE 20:1

THIS DRAWING IS A CONTROLLED DOCUMENT.		DWN B. MATTHEWS 29MAR2018	TE Connectivity
DIMENSIONS: mm		CHK D. HARMON 29MAR2018	
TOLERANCES UNLESS OTHERWISE SPECIFIED:		APVD D. HARMON 29MAR2018	NAME RECEPTACLE ASSEMBLY, RIGHT ANGLE, 56 POSITION, SLIVER 2.0
0 PLC ±	1 PLC ±	PRODUCT SPEC 108-130021	SIZE A1
2 PLC ±	3 PLC ±	APPLICATION SPEC 114-130015	CAGE CODE 00779
4 PLC ±	ANGLES ±	WEIGHT -	SCALE 10:1
MATERIAL	FINISH	CUSTOMER DRAWING	SHEET 3 OF 4

REVISIONS				
P.	LTN	DESCRIPTION	DATE	APVD
-	-	SEE SHEET 1	-	-

TABLE 1: CONNECTOR CONTACT IDENTIFICATION \triangle \triangle \triangle

CONTACT NUMBER	SIDE A	SIDE B
1	GROUND	GROUND
2	SIGNAL	SIGNAL
3	SIGNAL	SIGNAL
4	GROUND	GROUND
5	SIGNAL	SIGNAL
6	SIGNAL	SIGNAL
7	GROUND	GROUND
8	SIGNAL	SIGNAL
9	SIGNAL	SIGNAL
10	GROUND	GROUND
11	SIGNAL	SIGNAL
12	SIGNAL	SIGNAL
13	GROUND	GROUND
14	SIGNAL	SIGNAL
15	SIGNAL	SIGNAL
16	GROUND	GROUND
17	SIGNAL	SIGNAL
18	SIGNAL	SIGNAL
19	GROUND	GROUND
20	SIGNAL	SIGNAL
21	SIGNAL	SIGNAL
22	GROUND	GROUND
23	SIGNAL	SIGNAL
24	SIGNAL	SIGNAL
25	GROUND	GROUND
26	SIGNAL	SIGNAL
27	SIGNAL	SIGNAL
28	GROUND	GROUND

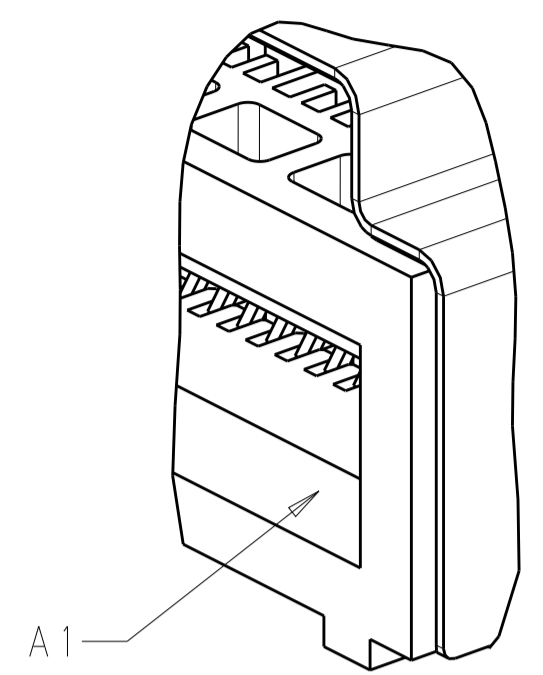

DETAIL B
SCALE 10:1

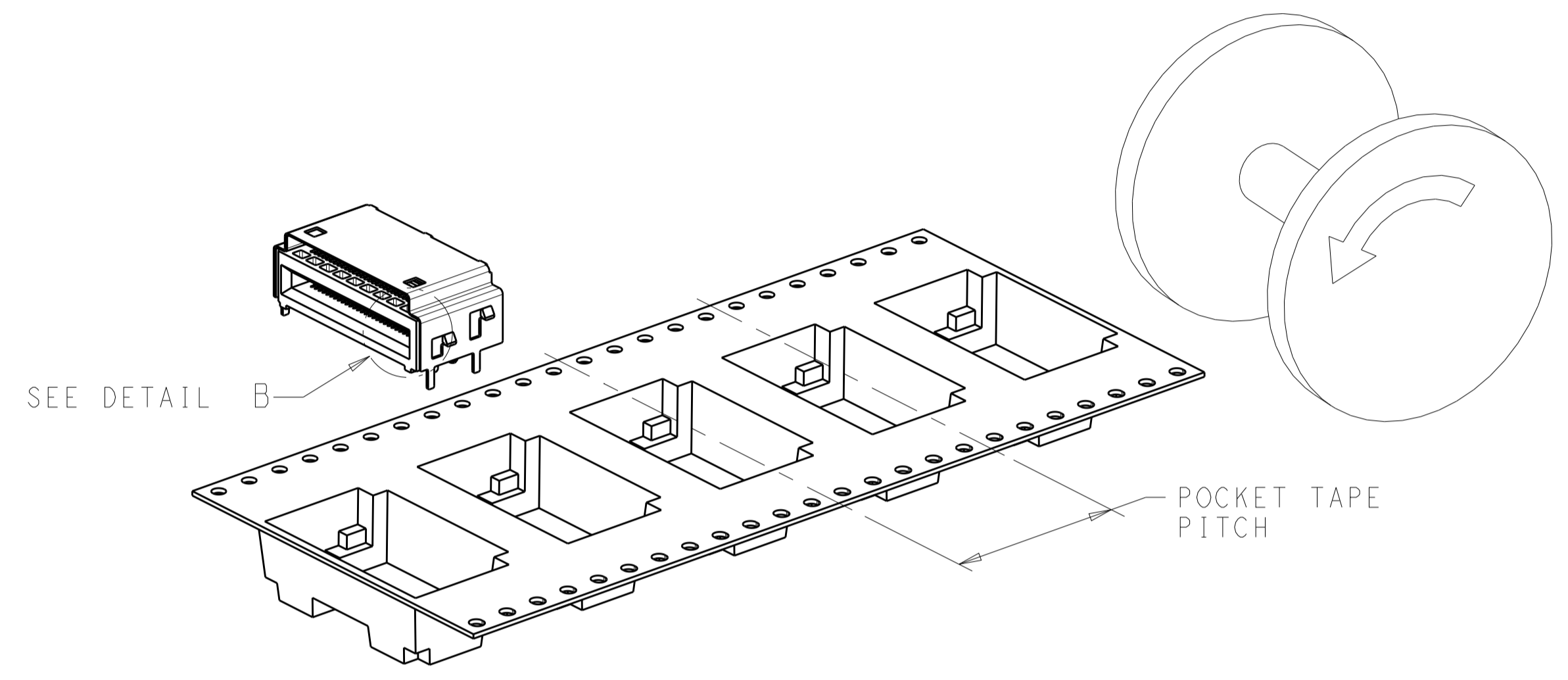

FIGURE 1 \triangle \triangle \triangle
 DIRECTION OFF TOP OF REEL
 FOR USER UNREELING
 SCALE 2:1

OBSOLETE	3±0.1	0.76µm Au	24	300	200	1-2332208-9
OBSOLETE		0.38µm Au			100	1-2332208-8
OBSOLETE		FLASH Au/PdNi			50	1-2332208-7
	1.2±0.2	0.76µm Au	24	300	200	1-2332208-6
		0.38µm Au			100	1-2332208-5
		FLASH Au/PdNi			50	1-2332208-4
	1.8 +0.2/-0.1	0.76µm Au	24	300	200	1-2332208-3
		0.38µm Au			100	1-2332208-2
		FLASH Au/PdNi			50	1-2332208-1
OBSOLETE	3±0.1	0.76µm Au	20	350	200	2332208-9
OBSOLETE		0.38µm Au			100	2332208-8
OBSOLETE		FLASH Au/PdNi			50	2332208-7
	1.2±0.2	0.76µm Au	20	350	200	2332208-6
		0.38µm Au			100	2332208-5
		FLASH Au/PdNi			50	2332208-4
	1.8 +0.2/-0.1	0.76µm Au	20	350	200	2332208-3
		0.38µm Au			100	2332208-2
		FLASH Au/PdNi			50	2332208-1
A		PLATING	POCKET TAPE PITCH	REEL QUANTITY	MATING CYCLES	PART NUMBER

THIS DRAWING IS A CONTROLLED DOCUMENT. **STC** TE Connectivity

DIMENSIONS:	TOLERANCES UNLESS OTHERWISE SPECIFIED:	OWN: B. MATTHEWS 29MAR2018	NAME: RECEPTACLE ASSEMBLY, RIGHT ANGLE, 56 POSITION, SLIVER 2.0
mm	0 PLC ±	CHK: D. HARMON 29MAR2018	PRODUCT SPEC: 108-130021
	1 PLC ±	APVD: D. HARMON 29MAR2018	APPLICATION SPEC: -
	2 PLC ±		SIZE: 114-130015
	3 PLC ±		WEIGHT: -
	4 PLC ±		SCALE: 10:1
	ANGLES ±		SHEET 4 OF 4
MATERIAL:	FINISH:	CUSTOMER DRAWING	REV A

X-ON Electronics

Largest Supplier of Electrical and Electronic Components

Click to view similar products for [Standard Card Edge Connectors](#) category:

Click to view products by [TE Connectivity](#) manufacturer:

Other Similar products are found below :

[CR7E-30DB-3.96E\(72\)](#) [6364499-1](#) [6565204-6](#) [PKC-156](#) [1437274-4](#) [147889-1](#) [1489165-4](#) [EBT15622B2X](#) [1-582587-1](#) [284-0102-12100](#)
[286-0052-12101A](#) [306022901000000](#) [307-012-502-202](#) [307-056-520-300](#) [2129318-1](#) [245-062-520-350](#) [287-0032-12101](#) [306-028-525-102](#)
[307-072-526-202](#) [345-060-559-303](#) [392-008-559-201](#) [534671-1](#) [341-240-317](#) [345-044-500-300](#) [346-240-318](#) [395-100-524-300](#) [09-07-2032](#)
[10035388-802LF](#) [10115859-011LF](#) [10122859-009LF](#) [10127905-B04B24BLF](#) [530555-1](#) [5-678046-1](#) [73726-0005](#) [66308-1](#) [1-1437275-6](#)
[PEC-07-02-T-S-A](#) [346-014-520-801](#) [307-048-502-202](#) [CE100F22-9-C](#) [CE100F26-7-C](#) [CE100F28-3-D](#) [CE156F18-9-C](#) [CE156F22-5-D](#)
[CE156F22-9-C](#) [CT100F22-2-D](#) [CT100F22-3-D](#) [CT100F24-2-D](#) [CT100F24-3-D](#) [CT100F24-6-C](#)