

REVISIONS				
P.	LTN	DESCRIPTION	DATE	APP'D
B		REV PER ECO 18-019704	1-16-19	CT DM

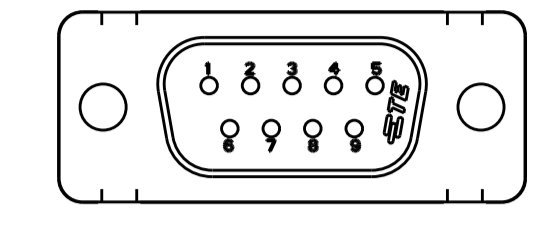

SIZE 1
SCALE 2:1

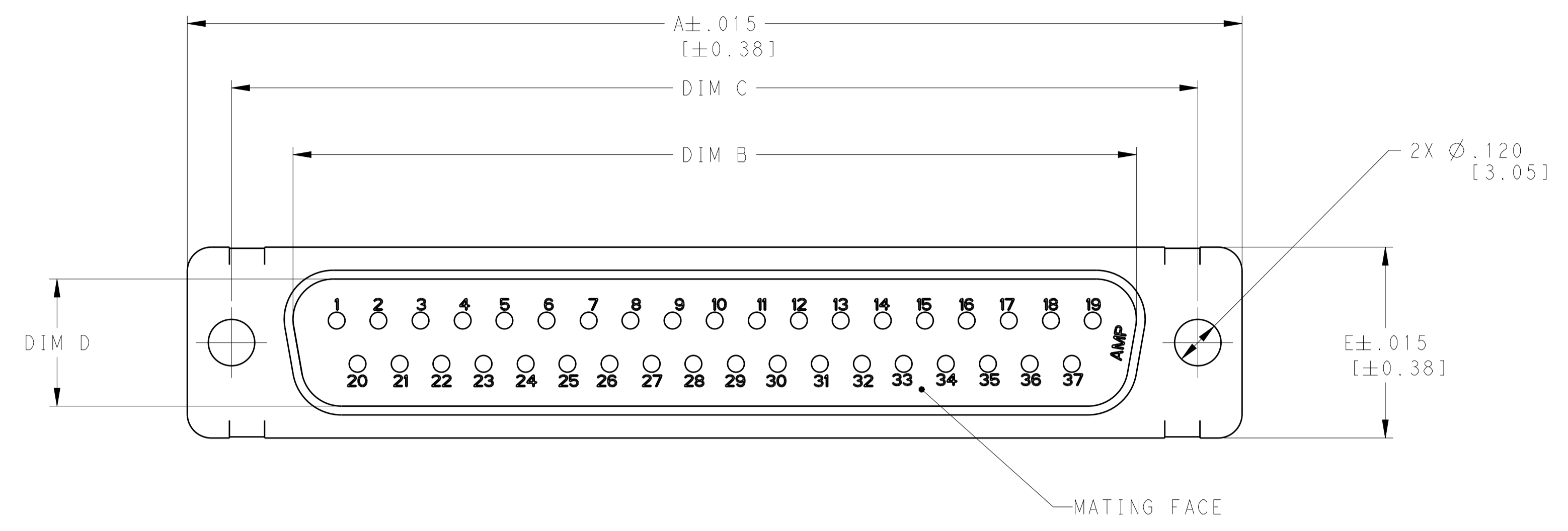
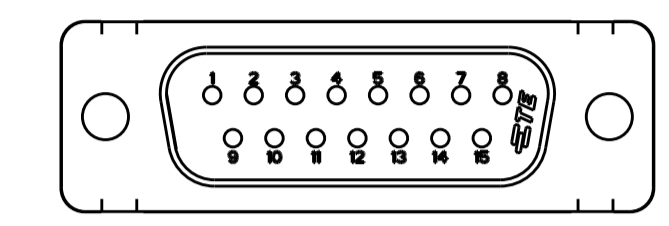

SIZE 2
SCALE 2:1

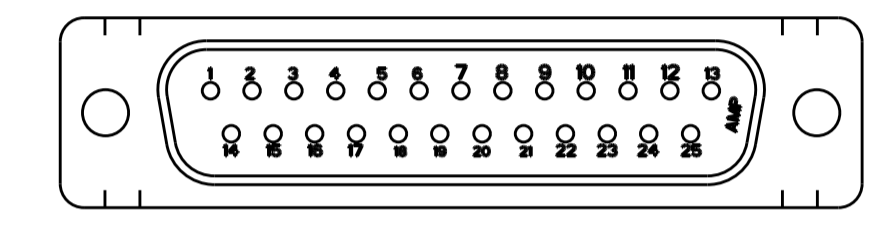

SIZE 3
SCALE 2:1

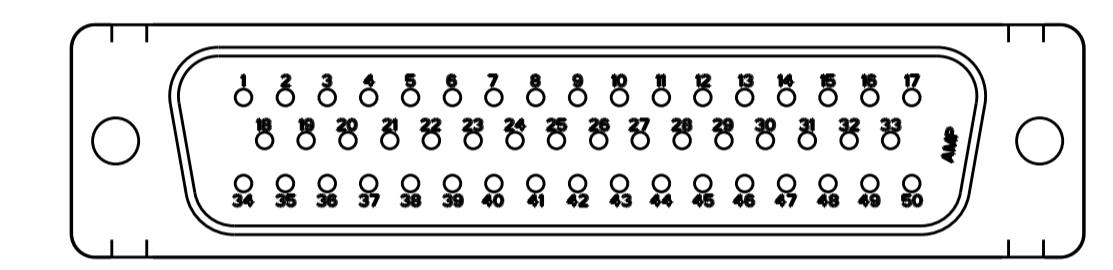

SIZE 5
SCALE 2:1

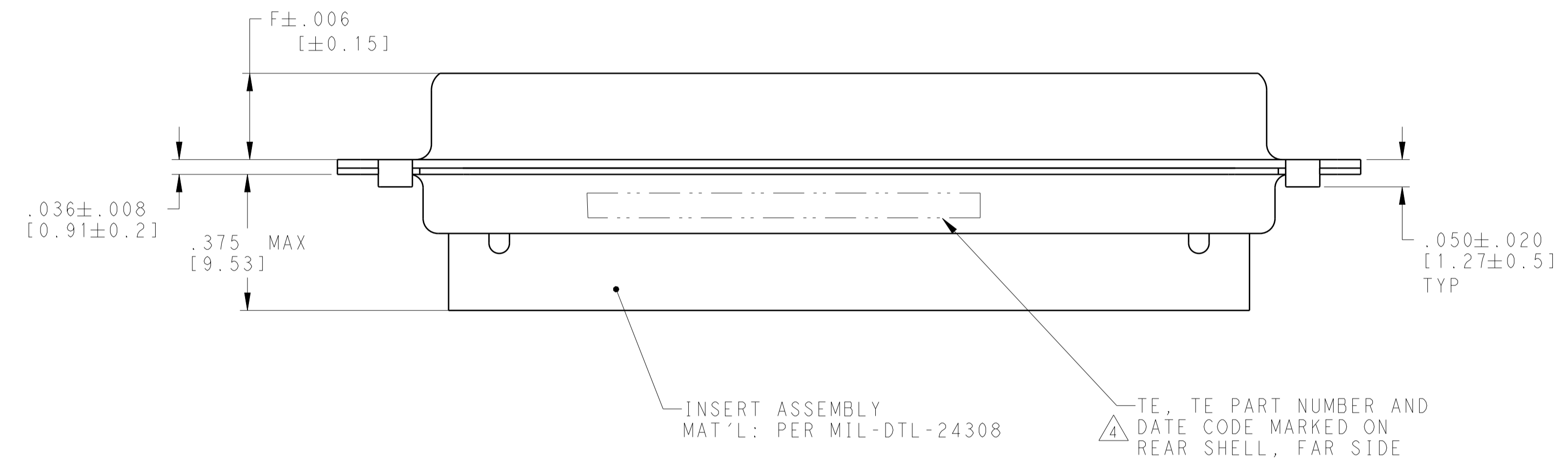

SHELL, FRONT & REAR
MAT'L: STAINLESS STEEL
FINISH: PASSIVATED

2335889-4 SHOWN

- THIS ASSEMBLY IS DESIGNED TO CONFORM TO THE LATEST ISSUE OF MIL-DTL-24308
- METAL RETENTION CLIPS ARE INCLUDED IN INSERTS.
- THIS PLUG WILL ACCEPT SIZE 20 PIN CONTACTS M39029/64-369 TE CONNECTIVITY PART NO. 205089-1. CONTACTS ARE NOT INCLUDED AND MUST BE ORDERED SEPARATELY.

MARKED WITH .047-.062 HIGH CHARACTERS. FAR SIDE REFERS TO THE WIDE SIDE OF THE KEYSTONE. NEAR SIDE REFERS TO THE NARROW SIDE OF THE KEYSTONE. IF THE REAR SHELL IS TOO SMALL FOR TE, TE PART NUMBER AND DATE CODE, THEN SPLIT AS FOLLOWS:
 A: TE PART ON REAR SHELL, NEAR SIDE
 B: TE AND DATE CODE ON REAR SHELL, FAR SIDE

DATE CODE IS FOUR DIGITS. FIRST TWO DIGITS REFER TO THE YEAR AND SECOND TWO DIGITS REFER TO THE WEEK.

2335890-5	.426 [10.82]	.230 [5.84]	.605 [15.37]	.441 [11.20]	2.406 [61.11]	2.079 [52.81]	2.635 [66.93]	50	5	2335889-5
2335890-4	.426 [10.82]	.230 [5.84]	.494 [12.55]	.329 [8.36]	2.500 [63.50]	2.182 [55.42]	2.729 [69.32]	37	4	2335889-4
2335890-3	.426 [10.82]	.230 [5.84]	.494 [12.55]	.329 [8.36]	1.852 [47.04]	1.534 [38.96]	2.088 [53.03]	25	3	2335889-3
2335890-2	.422 [10.72]	.233 [5.92]	.494 [12.55]	.329 [8.36]	1.312 [33.32]	.994 [25.25]	1.541 [39.14]	15	2	2335889-2
2335890-1	.422 [10.72]	.233 [5.92]	.494 [12.55]	.329 [8.36]	.984 [24.99]	.666 [16.92]	1.213 [30.81]	9	1	2335889-1
TE MATING PART NUMBER	DIM G	DIM F	DIM E	DIM D	DIM C	DIM B	DIM A	NUMBER OF POSITIONS	SHELL SIZE	TE PART NO.

THIS DRAWING IS A CONTROLLED DOCUMENT.		DWN C.C. THOMAS 8-21-18	21AUG2018
DIMENSIONS: INCHES [mm]		CHK D. MILLER 8-21-18	
TOLERANCES UNLESS OTHERWISE SPECIFIED:		APVD D. MILLER 8-21-18	
0 PLC ± 1 PLC ± 2 PLC ± 3 PLC ±.005 (0.13) 4 PLC ± ANGLES ±		NAME D. MILLER	PRODUCT SPEC
MATERIAL		APPLICATION SPEC	RESTRICTED TO
FINISH		WEIGHT	SCALE 4:1 SHEET 1 OF 1 REV B
CUSTOMER DRAWING		A100779C=2335889 PLUG ASSEMBLY, SIZE 1 THRU 5 SERIES 109, AMPLIMITE WITH STAINLESS STEEL SHELLS	

X-ON Electronics

Largest Supplier of Electrical and Electronic Components

Click to view similar products for [D-Sub Standard Connectors](#) category:

Click to view products by [TE Connectivity](#) manufacturer:

Other Similar products are found below :

[56F711-015](#) [012-9507-004](#) [LV242999-142T12](#) [015-0341-000](#) [015-0372-005](#) [015-0372-008](#) [015-8755-001](#) [020419-0104](#) [012-0467-000](#) [012-0515-000](#) [012-9507-034](#) [012-9507-114](#) [020745-0008](#) [609-25P](#) [M24308/2-23Z](#) [CT2-14S-2PCA34](#) [CT2-18-11PCAU](#) [CT2-36-15SC](#) [CT6-14S-2SC](#) [CT6E14SA7SC](#) [CT6E22-14PC](#) [CT6E22-14PS](#) [CT6E22-22PS](#) [M83513/01-FC](#) [M85049/48-3-2F](#) [6STD09PCM99B70X](#) [6STD09SCM99B30X](#) [6STD09SCT99S40X](#) [6STD15PCT99S40X](#) [6STD15SCM99B30X](#) [6STD15SCT99S40X](#) [6STF09PCM05B70X](#) [7-135760-9](#) [MC11E-10-6SN](#) [747552-3](#) [MD1-21PS](#) [MDM-15SCBRM7-F222](#) [MDM96517-699](#) [MDM96521-744](#) [MDVB1-21SL1](#) [MIK0-1-7SH003](#) [MIKQ6-7SH076](#) [MIKQ7-7PH077](#) [MIKQ7-7PH11](#) [MIKQ7-7PH32](#) [MIKQ9-7PH003](#) [MJSV-28SL61](#) [MKJ4A1F14-55S](#) [8-135760-3](#) [8STD09PCM99B30X](#)