



# PREMIUM QUALITY MANUFACTURING OF CRIMP CONNECTIONS

AMP 3K, 5K, GII AND GII<sup>+</sup> TERMINATORS

# Premium Quality Manufacturing of Crimp Connections

## AMP-O-LECTRIC GII Terminator



### GII Wire Processing Machine for Crimp Terminals

#### Specifications

Customer Manual - 409-32035

Crimp Force: 2268 kg [5000 lb] maximum crimp force capable of crimping 0.03–6.0 mm<sup>2</sup> [32-10 AWG]

Air: Pneumatic 620-760 kPa [90-100 psi] for models with air feed applicators and/or stripper module.

Electrical: 100-240 VAC, ± 10% AC, 50/60 Hz, Single phase. Operating current is 3 amps

\*Note: Customer must supply power cord and final connection

#### Safety first.

Improved guarding on the Model G II terminator provides open access for quick and smooth installation of both end-feed and side-feed applicator styles and meets applicable CE and domestic safety requirements.

#### Engineered with the operator in mind.

The Model G II is one of the quietest terminators on the market. It features improved access to, and significantly updated lighting in the under cabinet and target areas, and includes a variable speed option which gives the operator more flexibility for those tricky applications that benefit from slower ram and feed speeds. And, with its tool-less changeover capability, setup is both quick and easy.

#### Precision matters.

All Model G II Terminator versions include precision adjustment for crimp height — an important feature, which, in combination with the optional Crimp Quality Monitor (CQM II), enables repeatable, tight crimp tolerances required for today's demands for higher levels of quality. By simply resetting a dial, the operator can adjust crimp height in 0.013mm [.0005"] increments over a 0.457mm [.018"] range.

#### Complete control.

Our user-friendly LCD control panel includes simple button controls for: motor powering on and off, adjusting the ram speed, jogging the motor forward or in reverse, switching to split-cycle operation, work lighting, air feed, and batch counter reset. For improved quality, the controls also detect and report errors in the machine and stop cycling when a bad crimp is detected by the CQM II.

# Premium Quality Manufacturing of Crimp Connections

## AMP-O-LECTRIC GII Terminator

### Ordering Information

Description	Stroke	Baseplate	Part #
GII CE Terminator	40 MM	AMP Style	2217000-1
GII CE Terminator (W/CQM II)	40 MM	AMP Style	2217000-2
GII CE Terminator (W/Stripping Module)	40 MM	AMP Style	2217001-3
GII CE Terminator (W/Stripping Module and CQM II)	40 MM	AMP Style	2217001-4
GII CE Thru-Splice Terminator	40 MM	Thru-Splice	2217002-1
GII CE Thru-Splice Terminator (W/CQM II)	40 MM	Thru-Splice	2217002-2
GII CE Terminator (W/CQM II & Defective Crimp Cut Module)	40 MM	Thru-Splice	2362229-3

### Dimensions (without terminal reel and reel support)

Height: 520.7mm [20.5"]

Depth: 546.1mm [21.5"]

Width: 553.7mm [21.8"]

Weight: Approx. 104 kg [230 lb]

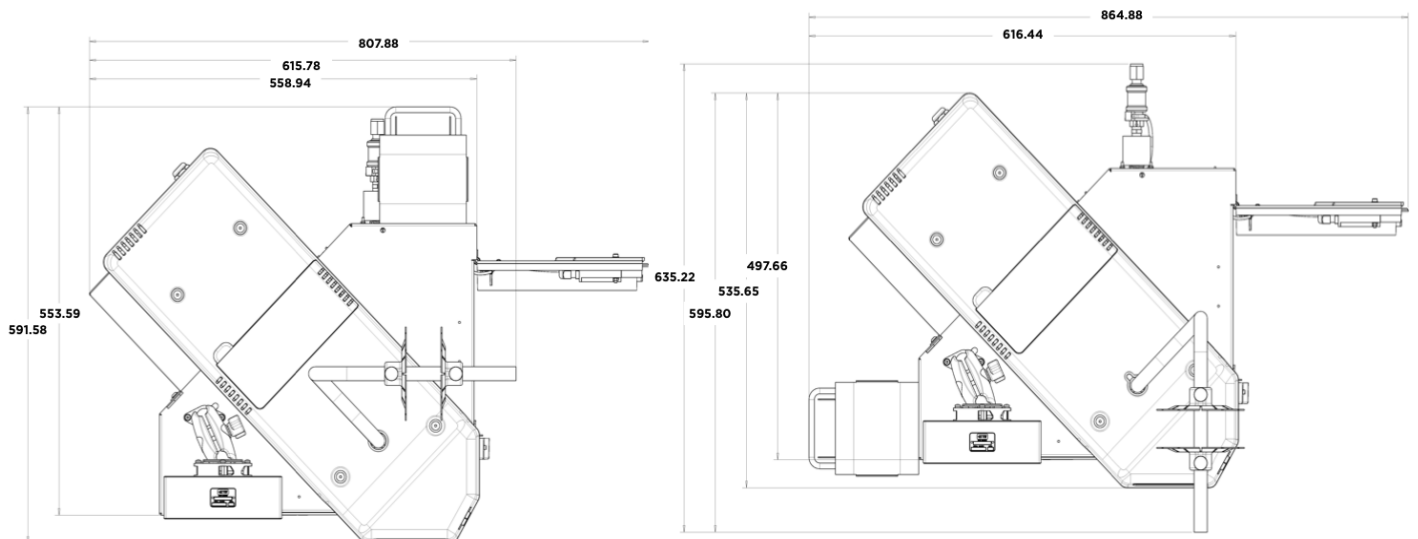

# Premium Quality Manufacturing of Crimp Connections

## AMP-O-LECTRIC GII<sup>+</sup> Terminator



### GII<sup>+</sup> Wire Processing Machine for High Voltage Terminals

#### Specifications

Customer Manual - 409-32035

Crimp Force: 4537 kg [10,000 lb] maximum crimp force

Air: Pneumatic 620-760 kPa [90-100 psi] for models w/air-feed applicators (Please refer to application logs for specific air requirements)

Electrical: 208-240 VAC, 50/60 Hz, Single Phase  
Operating current is 5 amps

\*Note: Customer must supply power cord and final connection

#### Engineered for higher voltage applications.

The Model G II<sup>+</sup> combines all the features of the popular GII line with the power to handle larger diameter wire sizes used for some high-voltage cable assemblies.

#### Complete control.

The user-friendly Crimp Quality II (CQM II) control panel includes simple button controls for: motor powering on and off, adjusting the ram speed, jogging the motor forward or in reverse, switching to split-cycle operation, work lighting, air feed, and batch counter reset. For improved quality, the controls also detect and report errors in the machine and stop cycling when a bad crimp is detected by the CQM II.

#### Precision matters.

All Model G II<sup>+</sup> Terminators include precision adjustment for crimp height — an important feature, which, in combination with the optional CQM II, enables repeatable, tight crimp tolerances required for today's demands for higher levels of quality. By simply resetting a dial, the operator can adjust crimp height in 0.013mm [.0005"] increments over a 0.457mm [.018"] range.

#### Engineered with the operator in mind.

The Model G II<sup>+</sup> utilizes strong LED lighting in the under cabinet and target areas to improve operator visibility. The standard variable-speed option gives the operator more flexibility for those tricky applications that benefit from slower ram and feed speeds. And, with its tool-less changeover capability, setup is both quick and easy.

# Premium Quality Manufacturing of Crimp Connections

## AMP-O-LECTRIC GII<sup>+</sup> Terminator

### Ordering Information

Model	Part Number	Applicator Type	Guard Insert	Existing Applicator Upgrade Kit	Standard Equipment
Base Model Base Model w/ CQM	2844800-1	Mid-Size Side Feed Mid-Size End Feed	2844807-1 (Shipped with Machine)	Not Required	Air Feed Kit 2217339-1
		Mid-Size Side/End Feed with Wire Seals	2844808-1	Not Required	
	2844800-2	Inverted AMPLIVAR Splice	2844818-1	Not Required	
		OCEAN Side Feed OCEAN End Feed	2844817-1	Not Required	
Loose Piece Loose Piece w/CQM	2844810-1	Loose Piece Mid- Size Applicators	2844813-1 (Shipped with Machine)	2844832-1	-
	2844810-2	Mini-Size Loose PieceSplice	2844814-1	2844827-1	-
Thru-splice Thru-splice w/CQM	2844820-1	Through Splice Mid-Size Side Feed	-	2844831-1	Air Feed Kit 2217339-1
	2844820-2	Through Splice Mid-Size End Feed	-	2844825-1	

### Dimensions (without terminal reel and reel support)

Height: 520.7mm [20.5"]

Depth: 635.2mm [25"]

Width: 624.3mm [24.5"]

Weight: Approx. 116 kg [255 lb]

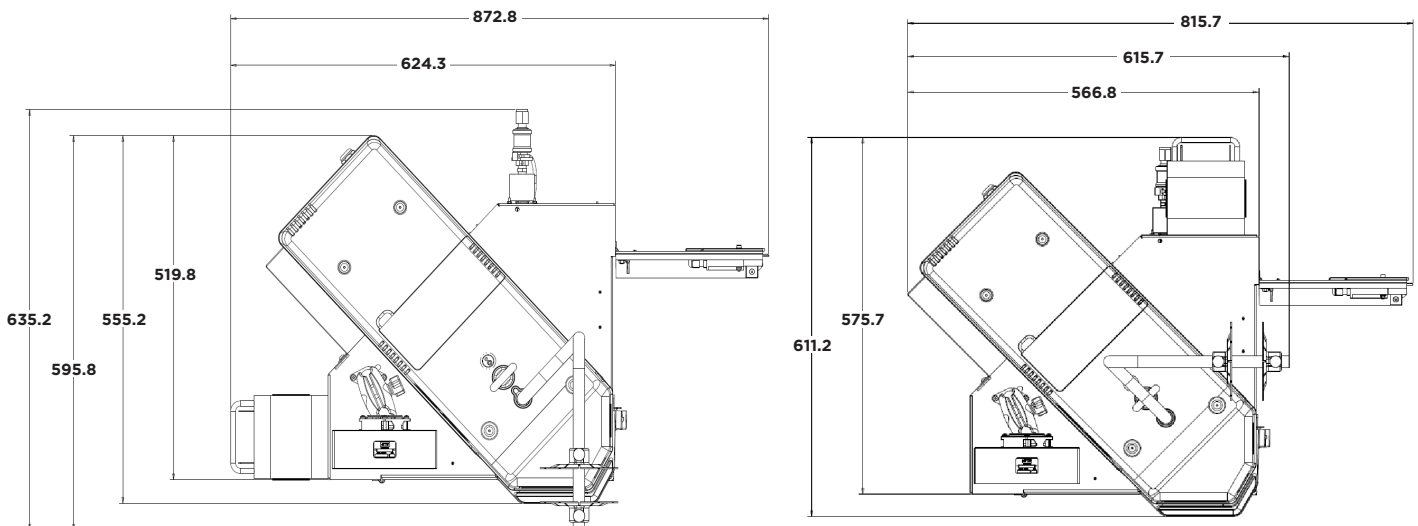

# Premium Quality Manufacturing of Crimp Connections

## AMP 3K/40, 5K/30 & 5K/40 Terminators

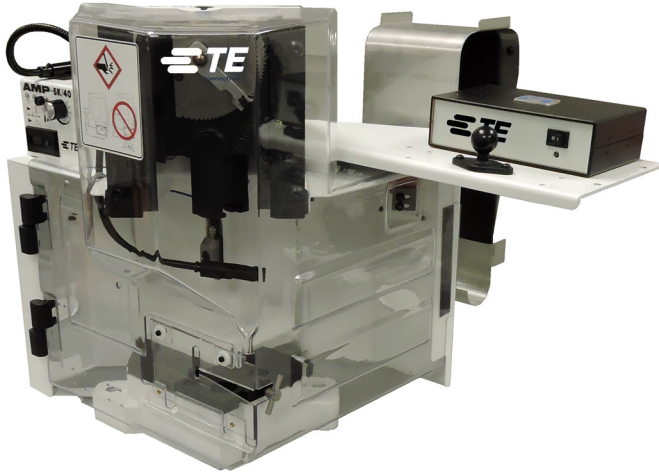

**AMP 5K/40 Wire Processing Machine**

### Specifications

Customer Manual: 409-10204

Crimp Force:

AMP 3K/40 max. 1.361 kg [3,000 lb] capable of crimping 0.03-2.5 mm<sup>2</sup> [32-14 AWG]

AMP 5K/40 max. 2.268 kg [5,000 lb] capable of crimping 0.03-6.0 mm<sup>2</sup> [32-10 AWG]

Cycle Time: Less than 0.4 seconds

Weight: 77.3 kg [170.4 lb]

Height: 585 mm [23 in.] without reel supports

Electrical Connection: 100-240 V, 50/60 Hz, single-phase  
Operating current is 3 amps

\*Note: Customer must supply power cord and final connection

Compressed Air: 620-760 kPa [90-100 psi], 2.83 l/s (6 scfm) (Please refer to application logs for specific air requirements)

### Features

- Tool-less removal of applicators and guards for quick and simple maintenance and product change over
- Universal electrical input
- Quiet and fast operation

AMP 3K/40 and 5K/40 terminators use a DC motor with gearbox drive. The result is a small-footprint design that is fast and quiet.

Cycle time is less than 0.4 seconds with an operation sound level of 76 dB(A).

Standard features such as tool-less precision crimp height adjust, CQM capability, batch counter and a work light are integral parts of serial equipment. By offering options the AMP 5K/40 terminator can be tailored to the specific application requirements without inflating the price for unwanted features.

Tooling for processing larger wire sizes is available upon request.

The AMP 3K/40 5K/40 terminator is CE approved.

### Standard Equipment (5K/40 Models only)

- Tool-less precision crimp height adjustment
- Manual shut height adjustment
- Batch counter
- Work light
- CQM capability
- Tool-less removal/exchange of applicators
- Jog capability
- Assembled with metric hardware

### Optional Equipment (5K/40 Models only)

- Pneumatic feed
- Crimp Quality Monitor (CQM II)
- Oiler kit

# Premium Quality Manufacturing of Crimp Connections

## AMP 3K/40, 5K/30 & 5K/40 Terminators

### Ordering Information

Description	Stroke	Baseplate	Part #
AMP 3K/40 CE EL Terminator	40 MM	AMP Style	2161400-5
AMP 5K/30 CE Universal Jam Terminator	30 MM	Universal JAM	2-2161500-1
AMP 5K/30 CE Universal Jam (W/ CQM II)	30 MM	Universal JAM	2-2161500-2
AMP 5K/40 CE Terminator	40 MM	AMP Style	2161500-1
AMP 5K/40 CE Terminator (W/ CQM II)	40 MM	AMP Style	2161500-2
AMP 5K/30 CE Terminator	30 MM	AMP Style	3-2161500-1
AMP 5K/30 CE Terminator (W/ CQM II)	30 MM	AMP Style	3-2161500-2
AMP 5K/40 CE Terminator (W/ Oversized Guard, AF)	40 MM	AMP Style	4-2161500-0
AMP 5K/40 CE Thru-Splice Terminator	40 MM	Thru Splice	2161300-1
AMP 5K/40 CE Thru-Splice Terminator (W/ CQM II)	40 MM	Thru Splice	2161300-2
AMP 5K/40 CE (W/ Strip Module)	40 MM	AMP Style	2161700-4
AMP 5K/40 CE (W/ Strip Module and CQM II)	40 MM	AMP Style	2161700-5
5K Atlantic Terminator (W/Defective crimp cut module)	40 MM	AMP Style	2362229-1
5K Pacific Terminator (W/Defective crimp cut module)	30 MM	AMP Style	2362229-2

### AMP 5K/30 & 5K/40 Terminator Layout and Dimensions

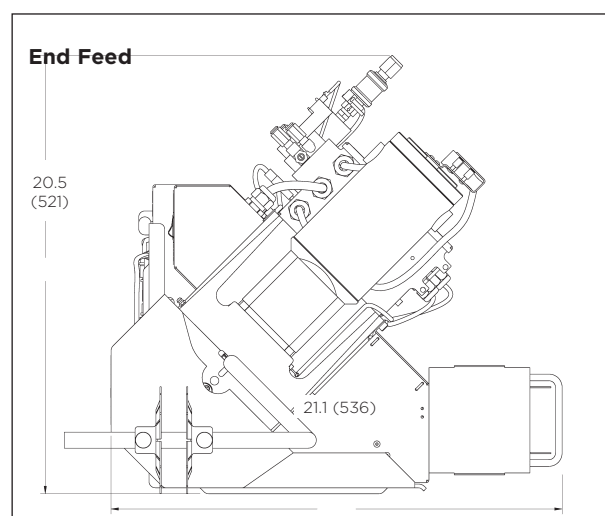
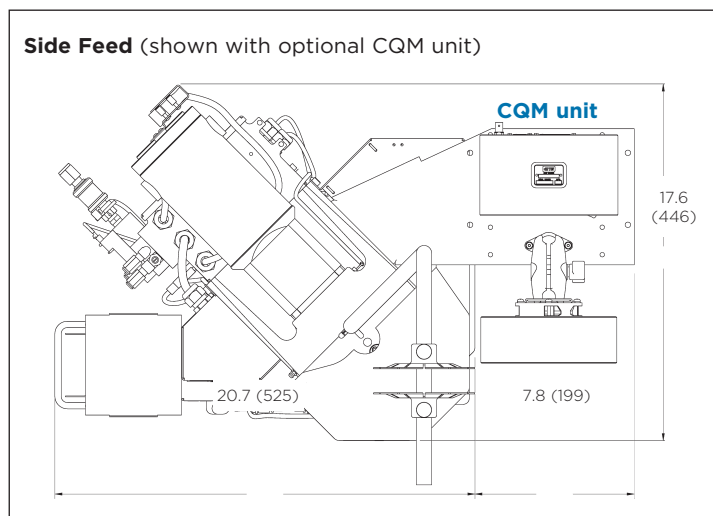



# Premium Quality Manufacturing of Crimp Connections

## AMP 5K/40 Terminators

### Capacitive Start Sensor

A retrofittable capacitive start sensor is available for 5K/40 Terminators with stripping modules.

Capacitive Start Sensor

2844876-2

### Short Strip Blades

Short strip blades for stripping down to 1.5MM strip length are available for 5K/40 Terminators with stripping modules.

Short Strip Blades

2217860-1

### Optional Stripping Module

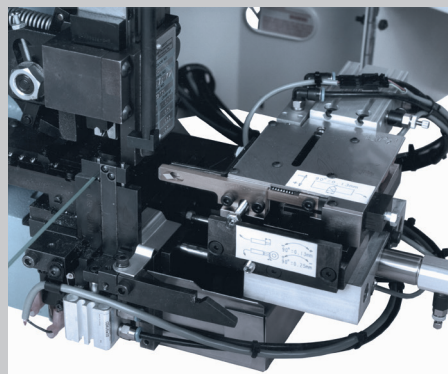

- For end- and side-feed applicators
- 3 modes of operation (Crimp only, strip only, or strip & crimp)
- Foot-switch or sensor activated
- Fast applicator changeover and easy adjustments
- Step mode for fast set-up
- Air blast ejects slugs into a collecting tray
- Compatible with crimp quality monitor

### Defective Crimp Cut

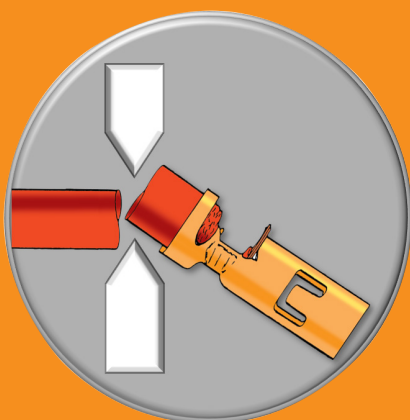

With the help of our CQM II, defective crimp cut technology can immediately detect when a bad crimp occurs and cut off the crimped terminal to ensure bad crimps don't accidentally pass to the next step in your wire harness manufacturing.

Defective crimp cut enabled terminators are available on select 5K and GII terminators.

Part #	Description
2362229-1	5K Atlantic Terminator (w/Defective Crimp Cut Module)
2362229-2	5K Pacific Terminator (w/Defective Crimp Cut Module)
2362229-3	GII CE Terminator (W/CQM II & Defective Crimp Cut Module)

Documentation should indicate the proper break-out length depending on the applicator/terminal/wire gauge. An example for the MQS can be explained in the documentation as a reference (2151493).



# Premium Quality Manufacturing of Crimp Connections

## AMP 5K/30 & 5K/40 Terminators

### Crimp Height Adjustment Using Precision Adjustment Mechanism

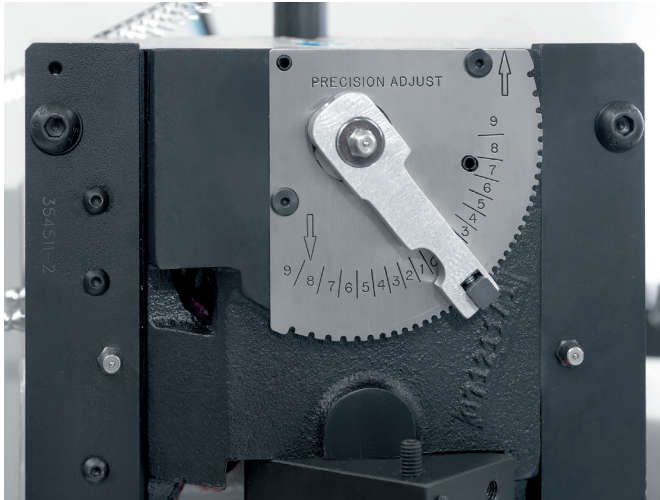

- Detent stops in the mechanism to adjust the crimp height
- Indexing the mechanism in either direction
- Change the crimp height in increments of approx. 0.013 mm [.0005 in.] per step
- Electric located in the ram linkage

Adjust the crimp height by moving the precision adjustment lever

- a.) To the right to increase the crimp height or
- b.) To the left to decrease the crimp height

## Airfeed Valve Assembly

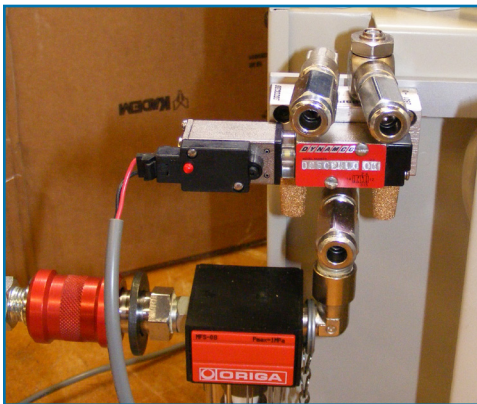

Part Number	Description	Purpose
2161209-1	Air Feed Valve Kit	Required to run applicators
2119955-1 (Side Feed) 2119955-2 (End Feed) 2119955-5 (Side Feed Rear Carrier)	Lubricator Bowl Assembly	Pre-lubricates the strip
1428156-1	Shoulder Eye Bolt	Provides a lift point for machine installation

## Gauges

Compatible with TE Connectivity and commercially available crimping presses, using quick changes style applicators.

### Applicator Gauge

Ideal instrument to assure correct positioning of all TE applicators

- Connectivity applicators
- Simple installation and use

Alignment Gauge

528440-5



# Premium Quality Manufacturing of Crimp Connections

## AMP 5K/30 & 5K/40 Terminators

### Control Panel



#### Decrease Speed

Decreases the motor speed for normal cycle operation and for jogging



#### Increase Speed

Increases the motor speed for normal cycle operation and for jogging



#### Error Reset

Clears the displayed error code



#### Count Reset

Clears the batch count to 0



#### Jog

Causes the DC motor to rotate at the jog speed set by the increase/decrease speed

### Base Plate



- The base plate with stripping unit as an option provides the mounting surface on which the applicator is installed.
- The applicator can be installed and removed with a long allen key.

#### Tape Guard Insert

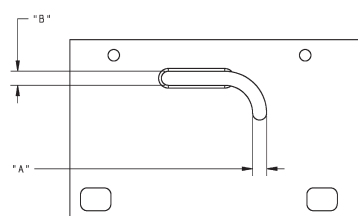

#### Standard Guard Insert

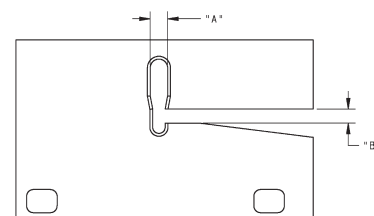

### Guard Insert Part Numbers

Guard Insert		Dimensions	
Part Number	Description	A	B
354529-2	Standard (away from the Applicator)	7.80 mm [.307 in ]	6.35 mm [.250in ]
1-679532-0	Standard (close to the Applicator) Shipped with the machine	6.22 mm [.245 in.]	5.08 mm [.200in ]
679994-2	Near Tape	6.35 mm [.250 in.]	6.35 mm [.250in ]
679995-2	Away from Tape	8.74 mm [.344 in.]	6.35 mm [.250in ]

**Note:** Some applications require the installation of an oversized guard kit 1976900-1. These applications are primarily ones that use two inch stroke air-feed cylinders.

# Premium Quality Manufacturing of Crimp Connections

## AMP 5K/30 & 5K/40 Terminators

### Optional CQM II Crimp Quality Monitor

When used on TE terminators the CQM II provides a complete crimp detection analysis. It checks every crimp as it is produced, measuring crimp height of each termination and evaluating the quality of each crimp. If a crimp has questionable characteristics, visual and audible alarms alert the operator. The CQM II includes data ports for printing and networking.

CQM II offers five different crimp analysis methods.

- Crimp height
- Work index
- Peak force
- Fast Fourier Transform (FFT)
- Point-to-point

#### Features

- Best measurement to check compliance with crimp design
- Real time measurement during crimp cycle
- Inspects 100% of terminations
- Crimp height measurement accuracy: +/-0.012 mm
- Data can be saved to a USB flash drive
- 5 unique analysis methods capable of detecting most crimp faults.

#### Operation Setup of CQM

- Simple set-up and operation through task-bar selections.
- The system walks the user through all necessary tasks required to start production.

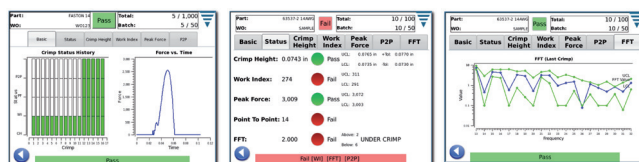

### Ordering Information for CQM II Kits

Part Number	Machine Description
2161670-1	AMP 5K/40 Terminator
2161670-2	AMP 5K/40 Terminator (w/ Stripping Module)
2161670-3	AMP 5K/30 Terminator (CQM II kit available for the 3K 30mm stroke machine)
2217288-1	GII Terminator
2217288-2	GII Terminator (w/ Stripping Module)

# Premium Quality Manufacturing of Crimp Connections

## Splice Terminator and Applicator

Applying thru-splices is fast and efficient when you have access to both sides of the applicator for placing and holding the wires.

The AMP 5K/40 splice terminator with a standard splice applicator provides front and rear access to maximize production efficiency. And it has full guarding for operator safety.

The splice terminator is offered in two versions, with and without crimp quality monitoring. Equipped with optional CQM II, force and position can be measured during every crimp cycle, providing real-time monitoring of crimp height, the fundamental crimp characteristic. The CQM II also monitors the shape of the work curve for every termination. Variations in the work curve may indicate improper wire placement, incorrect wire size, insulation in the wire barrel, tooling wear, etc. CQM II details and part numbers are shown on the other side of this sheet.

Like other AMP 5K/40 terminators, the splice version includes fine crimp height adjustment, full guarding with interlocks, and capabilities for jog operation. Splice terminators do not accept heavy-duty mini (HDM), heavy duty industrial (HDI) and OCEAN applicators.



### Features

- Open access behind crimper maximizes production efficiency
- All the features of the proven AMP 5K/40 terminating machine
- Magnet-wire splice capability
- Crimp Quality Monitor II (CQM II) option
- Precision manual crimp height adjustment
- Low maintenance
- Standard 15/8 [41.3] stroke
- Manufactured under an ISO 9001 Certified Quality System
- Universal electric input 100/240 VAC, 50/60 Hz
- Customer Manual 409-10204

### Capacity

Max. 2.268 kg [5.000 lb] crimp force  
capable of crimping 0.03–6.0 mm<sup>2</sup> [32-10 AWG]

### Deflection

0.13 mm [.0046 in.] max. per  
4,448 N [1,000 lb] crimp force

### Noise Level

Less than 82 dB(A) typical at operator  
position with standard mechanical feed applicator

### Weight

77.3 kg [170.4 lb]

### Height

585 mm [23 in.] without reel supports

### Electrical Connection

100-240 V, 50/60 Hz,  
single-phase current. \*Note: Customer must supply power  
cord and final connection

### Compressed Air

620-760 kPa [90-100 psi],  
2.83 l/s (6 scfm)

### Physical Environment:

Temperature: 4-40° C [40-104° F]

Relative Humidity: Less than 95% (non-condensing)



# Premium Quality Manufacturing of Crimp Connections

## Splice Terminator and Applicator

### Layout and Dimensions

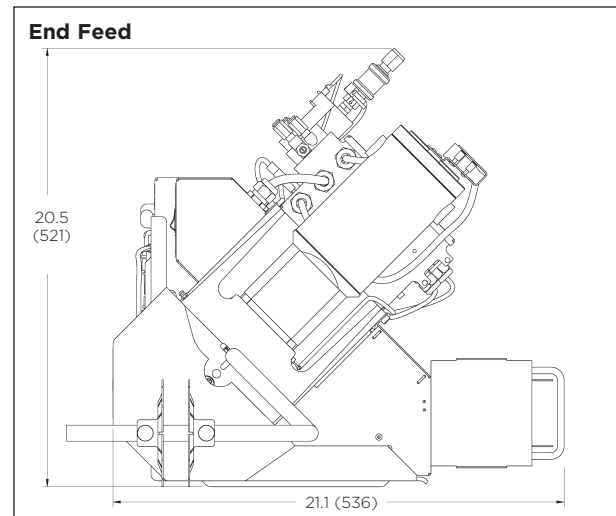
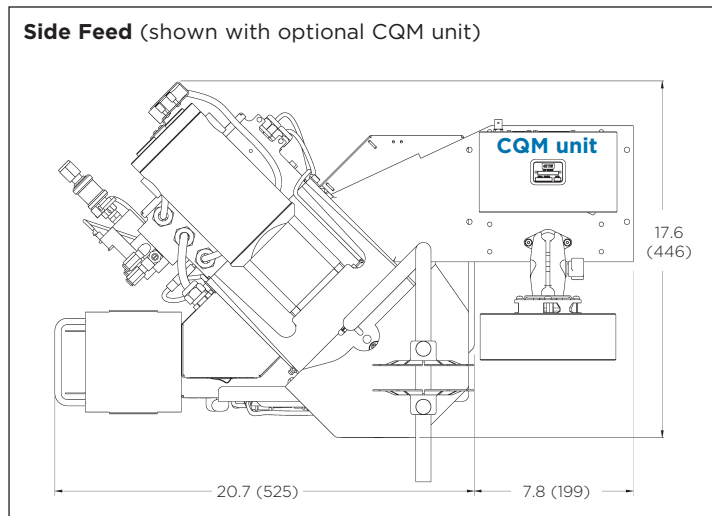

## Splice Terminator and Applicator

### Standard Splice Applicator

Use only with the splice terminator. Applicators are available for end- and side-reeled products. A dial-in setting provides quick adjustment of crimp height. All applicators use an air-feed mechanism. Applicator depends on terminal.

#### Features

- Instruction sheet 408-32027 splice applicator

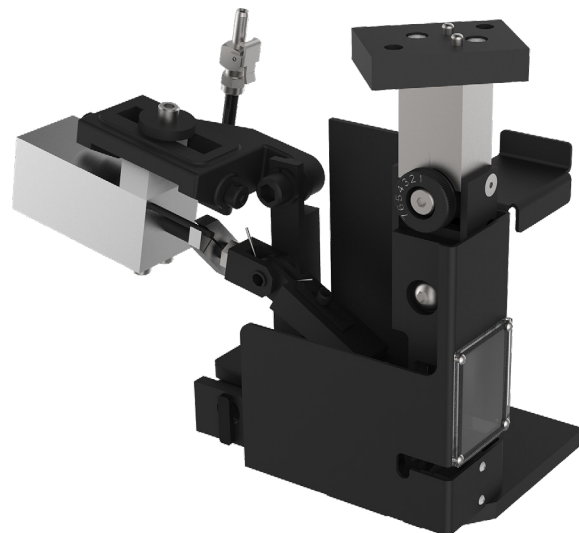

Part Number	Machine Description
2161300-1	AMP 5K/40 Splice Terminator with Manual Crimp Adjustment
2161300-2	AMP 5K/40 Splice Terminator with Manual Crimp Adjustment and CQM II
2161670-1	CQM II Kit









## Let's Connect

Learn more about our comprehensive line of tooling solutions at [tooling.te.com](http://tooling.te.com).

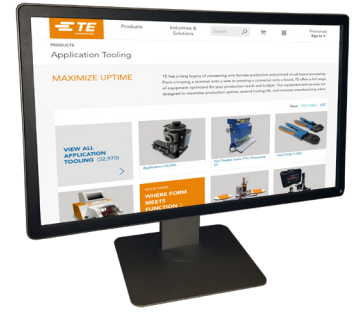

## TE Connectivity Technical Support Center

USA:	1.800.522.6752	UK:	+44.0800.267666
Canada:	1.800.522.6752	France:	+331.34.20.8686
Mexico:	+52.55.11.06.0800	Netherlands:	+31.73.624.6999
Latin/S. America	+54.11.4733.2200	China:	+86.400.820.6015
Germany:	+49.6151.607.1999		

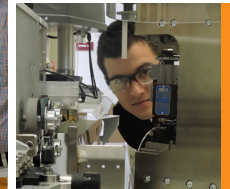
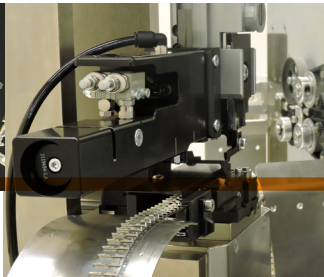
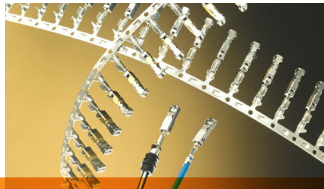

### te.com

OCEAN, AMP, AMP 3/K-40, AMP 5K/40, TE Connectivity and the TE connectivity (logo) are trademarks. All other logos, products and/or company names referred to herein might be trademarks of their respective owners. The information given herein, including drawings, illustrations and schematics which are intended for illustration purposes only, is believed to be reliable. However, TE Connectivity makes no warranties as to its accuracy or completeness and disclaims any liability in connection with its use. TE Connectivity's obligations shall only be as set forth in TE Connectivity's Standard Terms and Conditions of Sale for this product and in no case will TE Connectivity be liable for any incidental, indirect or consequential damages arising out of the sale, resale, use or misuse of the product. Users of TE Connectivity products should make their own evaluation to determine the suitability of each such product for the specific application.

© 2019 TE Connectivity Ltd. family of companies All Rights Reserved.

2338133-1 09/19 Rev A

#### Contact us today to learn more

E-mail (Americas): [fieldservicesnorthamerica@te.com](mailto:fieldservicesnorthamerica@te.com)

Phone (Americas): 800-722-1111 or 717-986-3434

E-mail (EMEA): [TEFE1@te.com](mailto:TEFE1@te.com)

Phone (EMEA): +49-6151-607-1518

For additional information download catalog no. 1-1307619-0 from [tooling.te.com](http://tooling.te.com).

[www.te.com](http://www.te.com)

## X-ON Electronics

Largest Supplier of Electrical and Electronic Components

*Click to view similar products for [Bench Top Tools](#) category:*

*Click to view products by [TE Connectivity](#) manufacturer:*

Other Similar products are found below :

[6-1372442-6](#) [63801-4462](#) [63801-4561](#) [63801-7269](#) [679527-1](#) [691667-1](#) [7-21000-9](#) [768539-1](#) [854130-1](#) [854946-2](#) [856203-1](#) [904449-1](#) [9-22280-9](#) [986096-2](#) [992438-3](#) [1-21000-3](#) [1-21000-1](#) [1-25022-4](#) [1302263353](#) [1302263355](#) [1302261057](#) [1302261101](#) [1302261206](#) [1302261560](#) [1302263123](#) [1302264036](#) [1424264-1](#) [1424267-1](#) [1428211-1](#) [1428287-1](#) [1-455755-6](#) [1752744-1](#) [18023-9](#) [189763-1](#) [1901726-1](#) [2079747-1](#) [21001-2](#) [2119083-1](#) [2119085-1](#) [2119371-1](#) [2161930-1](#) [2217088-2](#) [2217339-1](#) [2217347-1](#) [22281-9](#) [22374-7](#) [284565-000](#) [F1 Handle Spring](#) [19228-0213](#) [2030790-2](#)