

THIS DRAWING IS UNPUBLISHED. RELEASED FOR PUBLICATION
 © COPYRIGHT - By - ALL RIGHTS RESERVED.

| | | | | | | | |
|-----|------|-----------|-----|---------------------------|---------|-----|------|
| LOC | DIST | REVISIONS | | | | | |
| FB | 00 | P | LTR | DESCRIPTION | DATE | DWN | APVD |
| | | P | | REVISED PER ECO-11-005033 | 24MAR11 | RK | HMR |

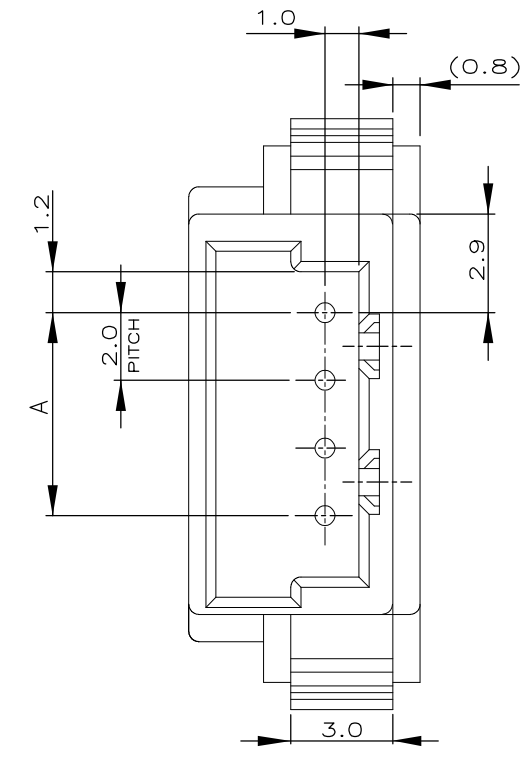
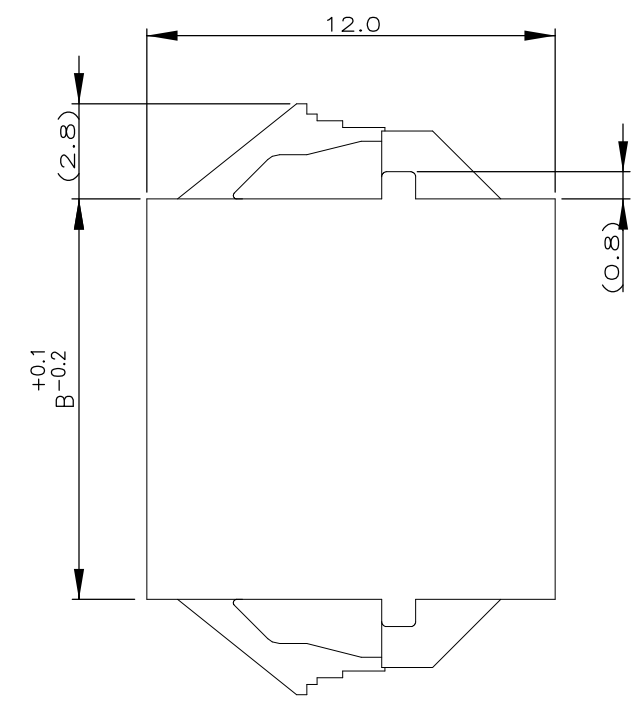
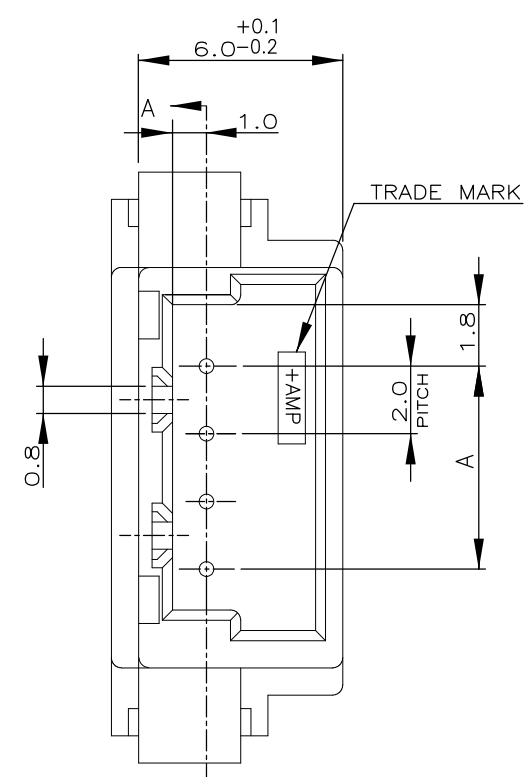

NOTES;

1. MATERIAL: HOUSING - 66 NYLON (UL94V-0)
POST - TIN BRASS
2. THE PANEL SHOULD BE PUNCHED SO THAT THE HOUSING ENTERS THE PANEL IN THE SAME DIRECTION AS PUNCH.

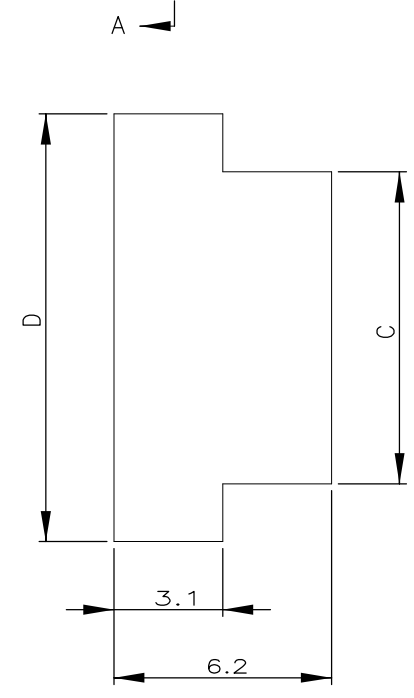
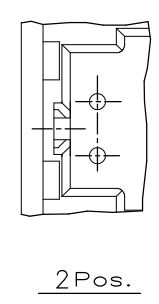
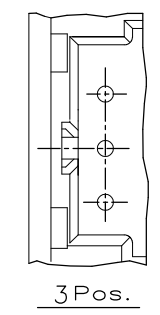

SECT. A-A

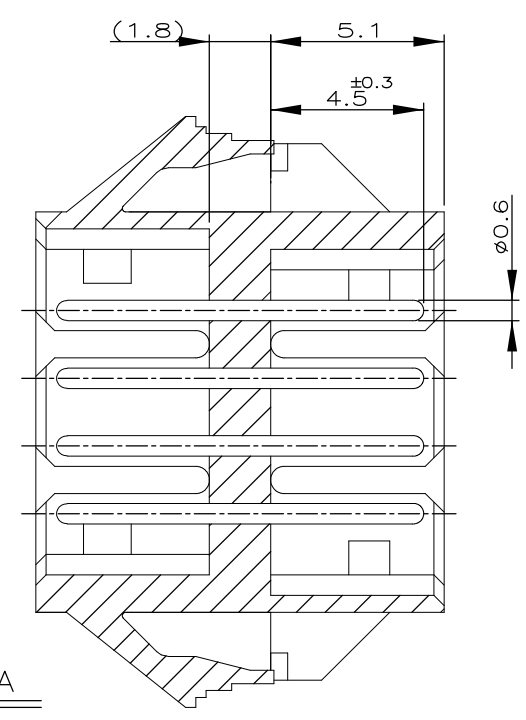

| | | | | | | | | |
|------------|------------|------------|------------|------|------|------|------|------|
| 7-292254-5 | 5-292254-5 | 3-292254-5 | 1-292254-5 | 15 | 37.6 | 34.0 | 33.8 | 28.0 |
| 7-▲-4 | 5-▲-4 | 3-▲-4 | 1-▲-4 | 14 | 35.6 | 32.0 | 31.8 | 26.0 |
| 7--3 | 5--3 | 3--3 | 1--3 | 13 | 33.6 | 30.0 | 29.8 | 24.0 |
| 7--2 | 5--2 | 3--2 | 1--2 | 12 | 31.6 | 28.0 | 27.8 | 22.0 |
| 7--1 | 5--1 | 3--1 | 1--1 | 11 | 29.6 | 26.0 | 25.8 | 20.0 |
| 7--0 | 5--0 | 3--0 | 1--0 | 10 | 27.6 | 24.0 | 23.8 | 18.0 |
| 6--9 | 4--9 | 2--9 | | 9 | 25.6 | 22.0 | 21.8 | 16.0 |
| 6--8 | 4--8 | 2--8 | | 8 | 23.6 | 20.0 | 19.8 | 14.0 |
| 6--7 | 4--7 | 2--7 | | 7 | 21.6 | 18.0 | 17.8 | 12.0 |
| 6--6 | 4--6 | 2--6 | | 6 | 19.6 | 16.0 | 15.8 | 10.0 |
| 6--5 | 4--5 | 2--5 | | 5 | 17.6 | 14.0 | 13.8 | 8.0 |
| 6--4 | 4--4 | 2--4 | | 4 | 15.6 | 12.0 | 11.8 | 6.0 |
| 6--3 | 4--3 | 2--3 | | 3 | 13.6 | 10.0 | 9.8 | 4.0 |
| 6-292254-2 | 4-292254-2 | 2-292254-2 | 292254-2 | 2 | 11.6 | 8.0 | 7.8 | 2.0 |
| BLACK | YELLOW | BLUE | NATURAL | Pos. | D | C | B | A |

PANEL CUTOUT DIMENSION (TOLERANCE:±0.1)
 (RECOMMENDED PANE THICKNESS:0.8mm ~ 1.6mm)

TOLERANCES UNLESS OTHERWISE SPECIFIED:

| | |
|-------------|---------|
| 10 ≥ * | : ±0.2 |
| 30 ≥ * >10 | : ±0.25 |
| 100 ≥ * >30 | : ±0.3 |
| ANGLE | : ±3' |

THIS DRAWING IS A CONTROLLED DOCUMENT.

| | | | |
|-------------------|---|------------------------|--|
| DIMENSIONS: mm | TOLERANCES UNLESS OTHERWISE SPECIFIED: | DWN S.XU 31JAN03 | TE Connectivity |
| | 0 PLC ±- 1 PLC ±- 2 PLC ±- 3 PLC ±- 4 PLC ±- ANGLES ±- | CHK S.YAO 31JAN03 | |
| | | APVD T. SASAKI 31JAN03 | |
| MATERIAL SEE NOTE | FINISH SEE NOTE | NAME T. SASAKI | |
| | | PRODUCT SPEC | PANEL MOUNT TYPE RELAY POST HEADER ASS'Y (AMP CT CONNECTOR 2mm PITCH) |
| | | APPLICATION SPEC | SIZE A3 CAGE CODE 00779 DRAWING NO C-292254 RESTRICTED TO |
| | | WEIGHT - | SCALE 5:1 SHEET 1 OF 1 REV P |

CUSTOMER DRAWING

X-ON Electronics

Largest Supplier of Electrical and Electronic Components

Click to view similar products for [Headers & Wire Housings](#) category:

Click to view products by [TE Connectivity](#) manufacturer:

Other Similar products are found below :

[892-18-020-10-001101](#) [58102-G61-06LF](#) [582553-1](#) [0009485154](#) [009176003701906](#) [0050291907](#) [LY20-4P-DT1-P1E-BR](#) [02.125.8002.8](#)
[609-3404](#) [61062-3](#) [61082-181009](#) [622-3653LF](#) [63453-116](#) [636-1030](#) [636-1427](#) [636-3427](#) [636-4007](#) [641938-9](#) [641991-4](#) [644827-2](#) [65817-](#)
[010LF](#) [65817-015LF](#) [65863-015LF](#) [66207-023LF](#) [67095-007LF](#) [67601157](#) [68645-018](#) [68648-049](#) [70.362.1628.0](#) [70-4210](#) [70-4226B](#) [70-](#)
[4853B](#) [707-5020](#) [707-5028](#) [71.350.2428.0](#) [71918-208LF](#) [71961-016LF](#) [733-134](#) [733-162](#) [754199-000](#) [760-3052](#) [787-8014-00](#) [79531-3000](#)
[FCN-360C032-B](#) [FCN-367T-T012/H](#) [FCN-723D010/2](#) [80.063.4001.1](#) [800-90-001-10-001000](#) [800-90-010-10-002000](#) [801-43-002-10-013000](#)