

THIS DRAWING IS UNPUBLISHED. RELEASED FOR PUBLICATION  
 © COPYRIGHT - By - ALL RIGHTS RESERVED.

| LOC |     | DIST        |  | REVISIONS                 |         |      |    |
|-----|-----|-------------|--|---------------------------|---------|------|----|
| P   | LTR | DESCRIPTION |  | DATE                      | DWN     | APVD |    |
| AF  | 50  | K           |  | REVISED PER ECR-13-004343 | 30JUL13 | KH   | KR |

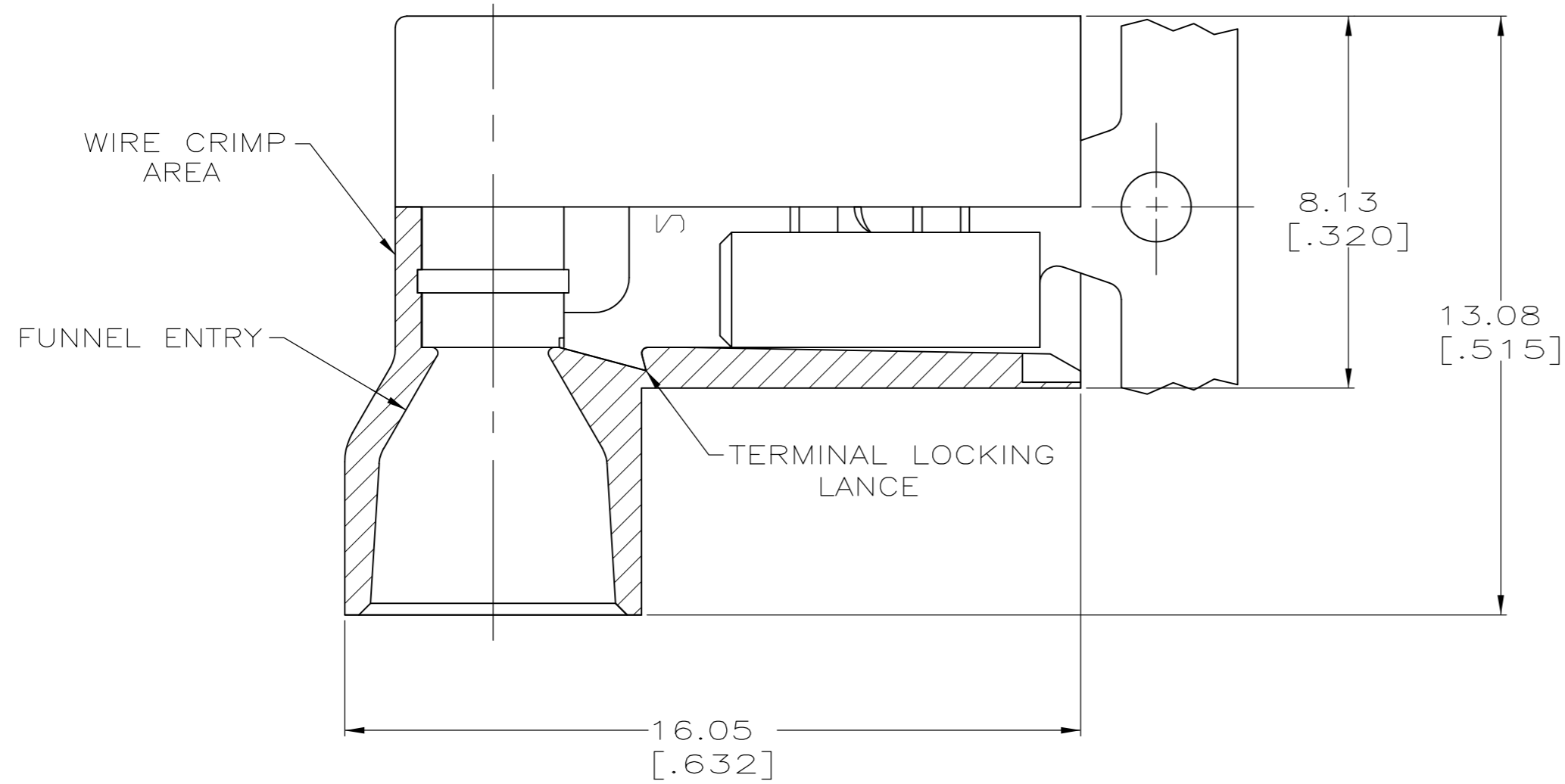

- 1 FITS 0.81±0.025 X 4.75 [.032±.001 X .187] TAB
- 2 WIRE SIZE: 1.3-2.0mm<sup>2</sup> [16-14 AWG], STRANDED ONLY. STRIP LENGTH 7.14 [.281]
- 3 INSULATION SIZE: 4.70 [.185] MAX DIA.
- 4 CONTINUOUS STRIP.

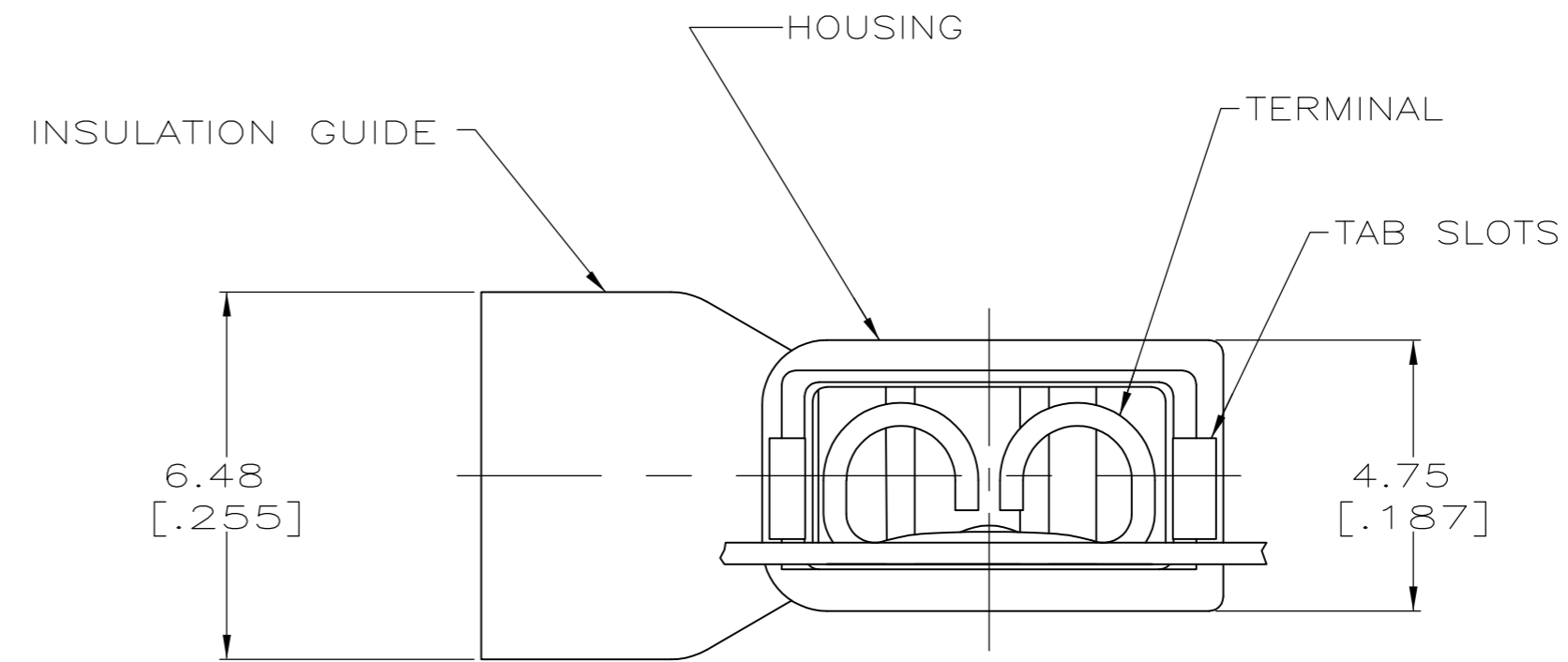
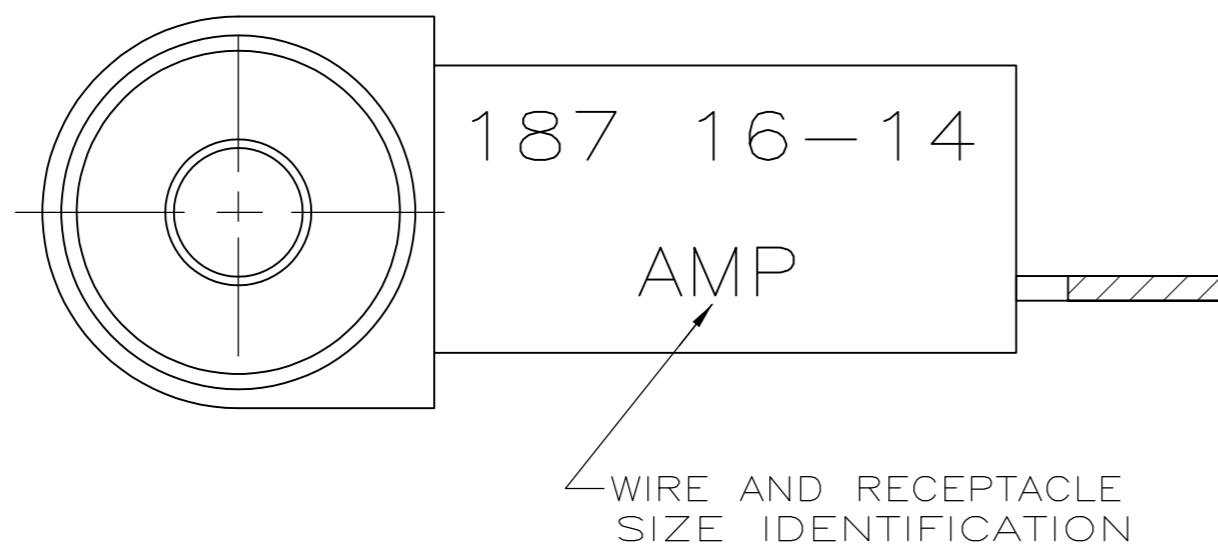

|                |                   |          |        |             |
|----------------|-------------------|----------|--------|-------------|
| TYPE 6/6 NYLON | BLACK TRANSLUCENT | BRASS    | TIN    | 9-520340-2  |
|                | BLUE TRANSLUCENT  |          |        | 3-520340-2  |
| MATERIAL       | COLOR             | MATERIAL | FINISH | PART NUMBER |

|                                                                                                                                                                                                                                                                |               |                       |                                                          |                     |     |       |     |       |               |       |     |       |     |        |
|----------------------------------------------------------------------------------------------------------------------------------------------------------------------------------------------------------------------------------------------------------------|---------------|-----------------------|----------------------------------------------------------|---------------------|-----|-------|-----|-------|---------------|-------|-----|-------|-----|--------|
| THIS DRAWING IS A CONTROLLED DOCUMENT.                                                                                                                                                                                                                         |               | DWN P FORTNEY 8/9/90  |                                                          |                     |     |       |     |       |               |       |     |       |     |        |
| DIMENSIONS: mm [INCHES]                                                                                                                                                                                                                                        |               | CHK JR RUTH 8/9/90    |                                                          |                     |     |       |     |       |               |       |     |       |     |        |
| TOLERANCES UNLESS OTHERWISE SPECIFIED:                                                                                                                                                                                                                         |               | APVD D BRATINA 8/9/90 |                                                          |                     |     |       |     |       |               |       |     |       |     |        |
| <table border="1"> <tr><td>0 PLC</td><td>± -</td></tr> <tr><td>1 PLC</td><td>± -</td></tr> <tr><td>2 PLC</td><td>± 0.38 [.015]</td></tr> <tr><td>3 PLC</td><td>± -</td></tr> <tr><td>4 PLC</td><td>± -</td></tr> <tr><td>ANGLES</td><td>± -</td></tr> </table> |               | 0 PLC                 |                                                          |                     | ± - | 1 PLC | ± - | 2 PLC | ± 0.38 [.015] | 3 PLC | ± - | 4 PLC | ± - | ANGLES |
| 0 PLC                                                                                                                                                                                                                                                          | ± -           |                       |                                                          |                     |     |       |     |       |               |       |     |       |     |        |
| 1 PLC                                                                                                                                                                                                                                                          | ± -           |                       |                                                          |                     |     |       |     |       |               |       |     |       |     |        |
| 2 PLC                                                                                                                                                                                                                                                          | ± 0.38 [.015] |                       |                                                          |                     |     |       |     |       |               |       |     |       |     |        |
| 3 PLC                                                                                                                                                                                                                                                          | ± -           |                       |                                                          |                     |     |       |     |       |               |       |     |       |     |        |
| 4 PLC                                                                                                                                                                                                                                                          | ± -           |                       |                                                          |                     |     |       |     |       |               |       |     |       |     |        |
| ANGLES                                                                                                                                                                                                                                                         | ± -           |                       |                                                          |                     |     |       |     |       |               |       |     |       |     |        |
| MATERIAL SEE TABLE                                                                                                                                                                                                                                             |               | FINISH SEE TABLE      | RECEPTACLE ASSEMBLY, ULTRA-FAST FLAG, 4.75 [.187] SERIES |                     |     |       |     |       |               |       |     |       |     |        |
| SEE TABLE                                                                                                                                                                                                                                                      |               | SEE TABLE             | SIZE A2                                                  | RESTRICTED TO -     |     |       |     |       |               |       |     |       |     |        |
| CUSTOMER DRAWING                                                                                                                                                                                                                                               |               | WEIGHT -              | CAGE CODE 00779                                          | DRAWING NO C=520340 |     |       |     |       |               |       |     |       |     |        |
|                                                                                                                                                                                                                                                                |               | SCALE 8:1             | SHEET 1 of 1                                             | REV K               |     |       |     |       |               |       |     |       |     |        |

## X-ON Electronics

Largest Supplier of Electrical and Electronic Components

*Click to view similar products for [Terminals](#) category:*

*Click to view products by [TE Connectivity](#) manufacturer:*

Other Similar products are found below :

[00-054007-01074-6](#) [00-054007-70206-1](#) [00-054007-70210-8](#) [00-054007-70217-7](#) [00-054007-70226-9](#) [00-054007-70228-3](#) [00-054007-70248-1](#) [00-054007-70256-6](#) [00-054007-70301-3](#) [00-054007-70316-7](#) [0-0320562-0](#) [00-054007-49560-4](#) [00-054007-70209-2](#) [00-054007-70225-2](#) [00-054007-70227-6](#) [00-054007-70231-3](#) [00-054007-70241-2](#) [00-054007-70242-9](#) [00-054007-70244-3](#) [00-054007-70246-7](#) [00-054007-70263-4](#) [00-054007-70288-7](#) [00-054007-70290-0](#) [00-054007-70300-6](#) [00-054007-70304-4](#) [01-2065-1-0216](#) [01-2900-1-04412](#) [00581P0075](#) [600TS-10](#) [60205-1](#) [604200-1](#) [605601-1](#) [60598-1-CUT-TAPE](#) [61314-6-C](#) [61810-3](#) [61-S](#) [61-SN](#) [626-0194](#) [62-NBM-A](#) [62-SN](#) [62-SP](#) [63-S](#) [640179-1](#) [M55155/059I03](#) [M55155/079C01](#) [M55155/099H02](#) [M55155/109H01](#) [M55155/109H02](#) [M55155/12XH05](#) [M55155/16XH02](#)