

Type 3631 Series

Key Features

- Very High Current Capability
- Wide Value Range
- Available in 6 different styles
- Up to 14A
- Down to 4mm height
- High reliability
- Taped and Reeled



The 3631 series of SMD shielded Power Inductors are designed to handle high current and have been designed for use in SMD power circuits. With the superior ferrite core material and its low profile construction we can ensure excellent inductance characteristics coupled with proven Tyco Sigma quality.

Electrical Characteristics - 3631A Series

Inductance Code	Inductance (μ H)	Tolerance	Test Freq. (Hz)	R.D.C. (m Ω) Max.	I.D.C. (A) Max.
2R5	2.5	\pm 20%	1K	24.0	5.00
5R0	5.0	\pm 20%	1K	35.0	4.00
7R5	7.5	\pm 20%	1K	40.0	3.50
100	10.0	\pm 20%	1K	54.0	3.00
120	12.0	\pm 20%	1K	65.0	2.80
150	15.0	\pm 20%	1K	70.0	2.70
180	18.0	\pm 20%	1K	82.0	2.60
220	22.0	\pm 20%	1K	95.0	2.40
250	25.0	\pm 20%	1K	120.0	2.00
330	33.0	\pm 20%	1K	145.0	1.80
390	39.0	\pm 20%	1K	160.0	1.65
500	50.0	\pm 10%	1K	200.0	1.50
560	56.0	\pm 10%	1K	240.0	1.40
680	68.0	\pm 10%	1K	280.0	1.30
750	75.0	\pm 10%	1K	330.0	1.20
101	100.0	\pm 10%	1K	400.0	1.00
121	120.0	\pm 10%	1K	500.0	0.90
151	150.0	\pm 10%	1K	580.0	0.80
181	180.0	\pm 10%	1K	750.0	0.70
221	220.0	\pm 10%	1K	840.0	0.65
271	270.0	\pm 10%	1K	1000.0	0.60
331	330.0	\pm 10%	1K	1340.0	0.54
391	390.0	\pm 10%	1K	1500.0	0.50
471	470.0	\pm 10%	1K	1980.0	0.45
561	560.0	\pm 10%	1K	2200.0	0.40
681	680.0	\pm 10%	1K	2400.0	0.35
821	820.0	\pm 10%	1k	3000.0	0.30

Type 3631 Series

Electrical Characteristics - 3631B Series

Inductance Code	Inductance (μH)	Tolerance	Test Freq. (Hz)	R.D.C. (mΩ) Max.	I.D.C. (A) Max.
2R5	2.5	±20%	1K	16.0	6.20
5R0	5.0	±20%	1K	22.0	4.70
7R5	7.5	±20%	1K	25.0	3.80
100	10.0	±20%	1K	35.0	3.30
120	12.0	±20%	1K	38.0	3.00
150	15.0	±20%	1K	42.0	2.80
180	18.0	±20%	1K	50.0	2.50
220	22.0	±20%	1K	62.0	2.30
270	27.0	±15%	1K	68.0	2.00
330	33.0	±15%	1K	90.0	1.90
390	39.0	±15%	1K	100.0	1.75
470	47.0	±15%	1K	130.0	1.60
560	56.0	±15%	1K	155.0	1.45
680	68.0	±15%	1K	170.0	1.30
820	82.0	±15%	1K	185.0	1.20
101	100.0	±10%	1K	220.0	1.10
121	120.0	±10%	1K	260.0	1.00
151	150.0	±10%	1K	320.0	0.90
181	180.0	±10%	1K	330.0	0.80
221	220.0	±10%	1K	460.0	0.70
271	270.0	±10%	1K	520.0	0.65
331	330.0	±10%	1K	660.0	0.60
391	390.0	±10%	1K	870.0	0.55
471	470.0	±10%	1K	970.0	0.50
561	560.0	±10%	1K	1320.0	0.45
681	680.0	±10%	1K	1500.0	0.40
821	820.0	±10%	1k	1700.0	0.35
102	1000.0	±10%	1K	2300.0	0.30
122	1200.0	±10%	1K	2650.0	0.25
152	1500.0	±10%	1K	3500.0	0.20

Electrical Characteristics - 3631C Series

Inductance Code	Inductance (μH)	Tolerance	Test Freq. (Hz)	R.D.C. (mΩ) Max.	I.D.C. (A) Max.
2R5	2.5	±20%	1K	11.4	7.80
4R5	4.5	±20%	1K	14.0	6.80
6R5	6.5	±20%	1K	18.0	6.50
100	10.0	±20%	1K	21.0	5.40
120	12.0	±20%	1K	25.0	4.90
150	15.0	±20%	1K	36.0	4.50
180	18.0	±20%	1K	40.0	3.90
220	22.0	±20%	1K	43.0	3.60
270	27.0	±20%	1K	48.0	3.40
330	33.0	±15%	1K	62.0	3.00
390	39.0	±15%	1K	76.0	2.70
470	47.0	±15%	1K	85.0	2.50
560	56.0	±15%	1K	110.0	2.30
680	68.0	±15%	1K	135.0	2.10
820	82.0	±15%	1K	150.0	1.90
101	100.0	±15%	1K	170.0	1.70
121	120.0	±15%	1K	190.0	1.50
151	150.0	±15%	1K	240.0	1.40
181	180.0	±15%	1K	270.0	1.30
221	220.0	±15%	1K	380.0	1.10
271	270.0	±15%	1K	400.0	1.00
331	330.0	±15%	1K	650.0	0.90
391	390.0	±15%	1K	670.0	0.85
471	470.0	±10%	1K	850.0	0.80
561	560.0	±10%	1K	900.0	0.70
681	680.0	±10%	1K	1000.0	0.65
821	820.0	±10%	1K	1150.0	0.60
102	1000.0	±10%	1K	1650.0	0.55
122	1200.0	±10%	1K	2000.0	0.40
152	1500.0	±10%	1K	2350.0	0.36

Type 3631 Series

Environmental Characteristics - A, B, C, Series

Storage Temp:	-50°C to +125°C
Operating Temp:	-25°C to +105°C
Rated Current:	Base on temp. rise & $\Delta L/L=10\%$ typ.
Temp. Rise:	40°C max.

Dimensions A, B, C Series

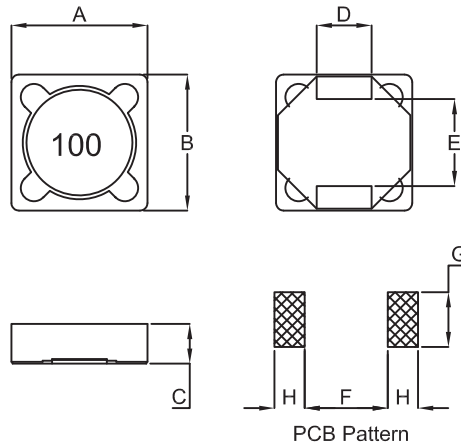

Series	A ± 0.3	B ± 0.3	C ± 0.5	D ± 0.2	E (typ)	F (ref)	G (ref)	H (ref)
3631A	12.7	12.7	5.0	5.0	8.1	6.0	7.0	4.0
3631B	12.7	12.7	6.0	5.0	8.1	6.0	7.0	4.0
3631C	12.7	12.7	8.0	5.0	8.1	6.0	7.0	4.0

Electrical Characteristics - 3631D Series

Inductance Code	Inductance (μH)	Tolerance	Test Freq. (Hz)	R.D.C. (m Ω) Max.	I _{rms} (A)	I _{sat} (A)
1R2	1.20	$\pm 30\%$	100K	8.0	9.20	9.80
2R4	2.40	$\pm 30\%$	100K	11.5	7.80	8.00
3R5	3.50	$\pm 30\%$	100K	13.0	7.50	7.60
4R7	4.70	$\pm 30\%$	100K	15.5	6.80	7.00
6R1	6.10	$\pm 30\%$	100K	17.0	6.60	6.80
7R6	7.60	$\pm 30\%$	100K	19.0	6.00	6.20
100	10.0	$\pm 20\%$	1K	20.0	5.50	5.50
120	12.0	$\pm 20\%$	1K	23.0	5.20	5.00
150	15.0	$\pm 20\%$	1K	27.0	5.00	4.60
180	18.0	$\pm 20\%$	1K	36.0	4.20	3.90
220	22.0	$\pm 20\%$	1K	43.0	4.00	3.70
270	27.0	$\pm 20\%$	1K	45.0	3.60	3.30
330	33.0	$\pm 20\%$	1K	60.0	3.00	2.80
390	39.0	$\pm 20\%$	1K	70.0	2.80	2.70
470	47.0	$\pm 20\%$	1K	86.0	2.60	2.50
560	56.0	$\pm 20\%$	1K	100.0	2.30	2.20
680	68.0	$\pm 20\%$	1K	110.0	2.10	2.10
820	82.0	$\pm 20\%$	1K	145.0	1.95	1.90
101	100.0	$\pm 20\%$	1K	180.0	1.70	1.70

Type 3631 Series

Electrical Characteristics - 3631E Series

Inductance Code	Inductance (μH)	Tolerance	Test Freq. (Hz)	R.D.C. (mΩ) Max.	I _{rms} (A)	I _{sat} (A)
1R5	1.5	±30%	100K	9.5	9.20	9.00
3R3	3.3	±30%	100K	15.0	6.80	6.50
4R7	4.7	±20%	100K	18.0	6.00	5.60
5R6	5.6	±20%	100K	20.0	5.40	5.10
6R8	6.8	±20%	100K	23.0	5.20	4.70
100	10.0	±20%	100K	32.0	4.00	4.00
150	15.0	±20%	100K	47.0	3.50	3.20
220	22.0	±20%	100K	67.5	3.00	2.60
330	33.0	±20%	100K	97.0	2.30	2.10
470	47.0	±20%	100K	135.0	2.00	1.80
680	68.0	±20%	100K	200.0	1.50	1.50
101	100.0	±20%	100K	300.0	1.25	1.20

Electrical Characteristics - 3631F Series

Inductance Code	Inductance (μH)	Tolerance	Test Freq. (Hz)	R.D.C. (mΩ) Max.	I _{rms} (A)	I _{sat} (A)
1R1	1.1	±30%	100K	6.5	10.2	14.0
2R4	2.4	±30%	100K	10.0	9.2	10.5
3R3	3.3	±30%	100K	12.0	8.8	9.8
4R5	4.5	±30%	100K	13.5	8.5	9.0
5R6	5.6	±30%	100K	16.0	8.0	8.5
7R5	7.5	±30%	100K	17.5	6.4	7.0
100	10.0	±20%	1K	19.5	6.0	6.3
150	15.0	±20%	1K	28.5	5.2	5.0
220	22.0	±20%	1K	38.6	4.3	4.1
330	33.0	±20%	1K	57.0	3.5	3.3
470	47.0	±20%	1K	80.0	2.9	2.8
680	68.0	±20%	1K	120.0	2.4	2.3
101	100.0	±20%	1K	150.0	2.1	2.0

Environmental Characteristics - D, E, F Series

Storage Temp:	-40°C to +125°C
Operating Temp:	-40°C to +125°C (Temp. Rise Included)
Rated Current:	Base on temp. rise & ΔL/L=25% typ.
Temp. Rise:	40°C typ.

Type 3631 Series

Electrical Characteristics - 3631G Series

Inductance Code	Inductance (μ H)	DC Resistance (milli Ohm max)	Rated Current (A max)
1R2	1.2	7.0	9.80
2R4	2.4	11.5	8.00
3R5	3.5	13.5	7.50
4R7	4.7	15.8	6.80
6R1	6.1	17.6	6.60
7R6	7.6	20.0	5.90
100	10	21.6	5.40
120	12	24.3	4.90
150	15	27.0	4.50
180	18	39.2	3.90
220	22	43.2	3.60
270	27	45.9	3.40
330	33	64.8	3.00
390	39	72.9	2.75
470	47	100	2.50
560	56	110	2.35
680	68	140	2.10
820	82	180	1.95
101	100	220	1.70
121	120	250	1.60
151	150	280	1.42
181	180	450	1.30
221	220	390	1.16
271	270	560	1.06
331	330	640	0.95
391	390	700	0.88
471	470	980	0.79
561	560	1070	0.73
681	680	1460	0.67
821	820	1640	0.60
102	1000	1820	0.55

Environmental Characteristics - G Series

Inductance Measuring Frequency:	1,0-8.2 μ H (7,96MHz) 10 μ H (1KHz 1Vrms)
Inductance Tolerance:	J \pm 5%, K \pm 10%, L \pm 15%, M \pm 20%, N \pm 30%
Inductance Drop:	20% typ. or temperature rise Δ t \leq 40°C at rated current
Operating Temperature Range:	-40°C to +85°C
Electrical Specifications:	at 25°C

Type 3631 Series

Dimensions D, E, F, G Series

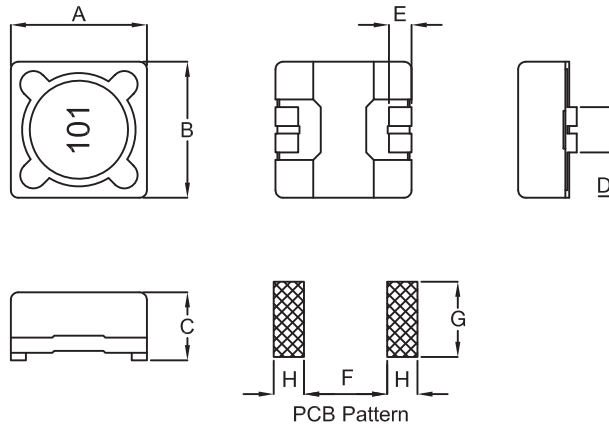

Series	A ±0.3	B ±0.3	C ±0.5	D ±0.3	E (typ)	F (ref)	G (ref)	H (ref)
3631D	12.5	12.5	6.0	5.0	7.0	6.8	5.4	2.9
3631E	12.5	12.5	4.0	5.0	7.0	6.8	5.4	2.9
3631F	12.5	12.5	7.5	5.0	7.0	6.8	5.4	2.9
3631G	12.0	12.0	8.0 max	4.9±0.2	2.0	7.4	5.4	2.6

Reliability Test - D, E, F Series

Test Item	Specification	Test Condition
Temperature Cycling:	$\Delta L/L \leq \pm 20\%$	Room Temp. $\rightarrow -25 \pm 2^\circ\text{C}$ 15 minutes \rightarrow 30 minutes Room Temp. $\rightarrow 85 \pm 2^\circ\text{C}$ 15 minutes \rightarrow 30 minutes Total: 50 cycles
Humidity Resistance Test:	$\Delta L/L \leq \pm 20\%$	Temperature: $40 \pm 2^\circ\text{C}$ Humidity: 90 ~ 95% Applied Current: Per spec. Time: 500 hours
High Temp. Resistance Test:	$\Delta L/L \leq \pm 20\%$	Temperature: $85 \pm 2^\circ\text{C}$ Applied Current: Per spec. Time: 500 hours

How to Order

3631	A	2R5	K	T
Common Part	Style	Inductance	Tolerance	Package
3631	A, B, C, D, E, F or G	See Relevant Table for Inductance Code	K - $\pm 10\%$ L - $\pm 15\%$ M - 20% N - 30%	T - Taped and Reeled

TE Connectivity, TE connectivity (logo) and TE (logo) are trademarks.
 Other logos, product and Company names mentioned herein may be trademarks of their respective owners.

While TE has made every reasonable effort to ensure the accuracy of the information in this datasheet, TE does not guarantee that it is error-free, nor does TE make any other representation, warranty or guarantee that the information is accurate, correct, reliable or current. TE reserves the right to make any adjustments to the information contained herein at any time without notice. TE expressly disclaims all implied warranties regarding the information contained herein, including, but not limited to, any implied warranties of merchantability or fitness for a particular purpose. The dimensions in this datasheet are for reference purposes only and are subject to change without notice. Specifications are subject to change without notice. Consult TE for the latest dimensions and design specifications.

X-ON Electronics

Largest Supplier of Electrical and Electronic Components

Click to view similar products for [Fixed Inductors](#) category:

Click to view products by [TE Connectivity](#) manufacturer:

Other Similar products are found below :

[MLZ1608M6R8WTD25](#) [MLZ1608N6R8LT000](#) [MLZ1608N3R3LTD25](#) [MLZ1608N3R3LT000](#) [MLZ1608N150LT000](#)

[MLZ1608M150WTD25](#) [MLZ1608M3R3WTD25](#) [MLZ1608M3R3WT000](#) [MLZ1608M150WT000](#) [MLZ1608A1R5WT000](#)

[MLZ1608N1R5LT000](#) [B82432C1333K000](#) [PCMB053T-1R0MS](#) [PCMB053T-1R5MS](#) [PCMB104T-1R5MS](#) [CR32NP-100KC](#) [CR32NP-](#)

[151KC](#) [CR32NP-180KC](#) [CR32NP-181KC](#) [CR32NP-1R5MC](#) [CR32NP-390KC](#) [CR32NP-3R9MC](#) [CR32NP-680KC](#) [CR32NP-820KC](#)

[CR32NP-8R2MC](#) [CR43NP-390KC](#) [CR43NP-560KC](#) [CR43NP-680KC](#) [CR54NP-181KC](#) [CR54NP-470LC](#) [CR54NP-820KC](#) [CR54NP-8R5MC](#)

[MGDQ4-00004-P](#) [MGDU1-00016-P](#) [MHL1ECTTP18NJ](#) [MHL1JCTTD12NJ](#) [PE-51506NL](#) [PE-53601NL](#) [PE-53630NL](#) [PE-53824SNLT](#) [PE-](#)

[62892NL](#) [PE-92100NL](#) [PG0434.801NLT](#) [PG0936.113NLT](#) [PM06-2N7](#) [PM06-39NJ](#) [HC2LP-R47-R](#) [HC2-R47-R](#) [HC3-2R2-R](#) [HC8-1R2-R](#)