

LOC		DIST		REVISIONS			
AD	00	REV	DATE	BY	CHK	APPV	
C		REVISED PER ECO-10-023600	1NOV2010	RC		CW	
D		ECR-12-010652	06NOV12	SY		AC	

**CONNECTOR ASSEMBLY
EXAMPLARY LOADED**

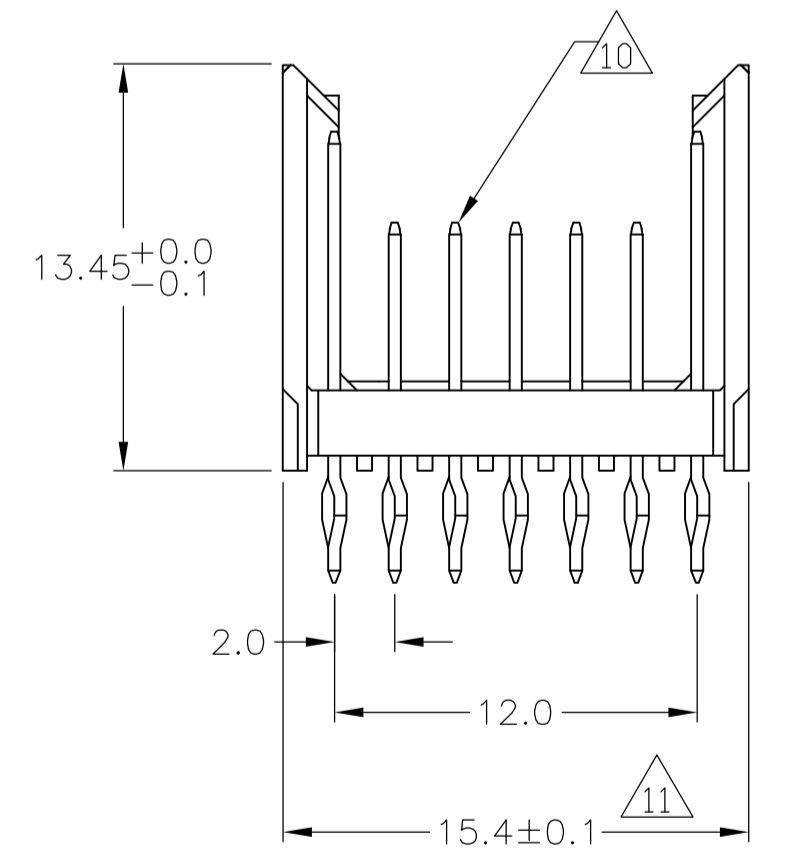

CONTACT DIMENSIONS
SCALE 5:1

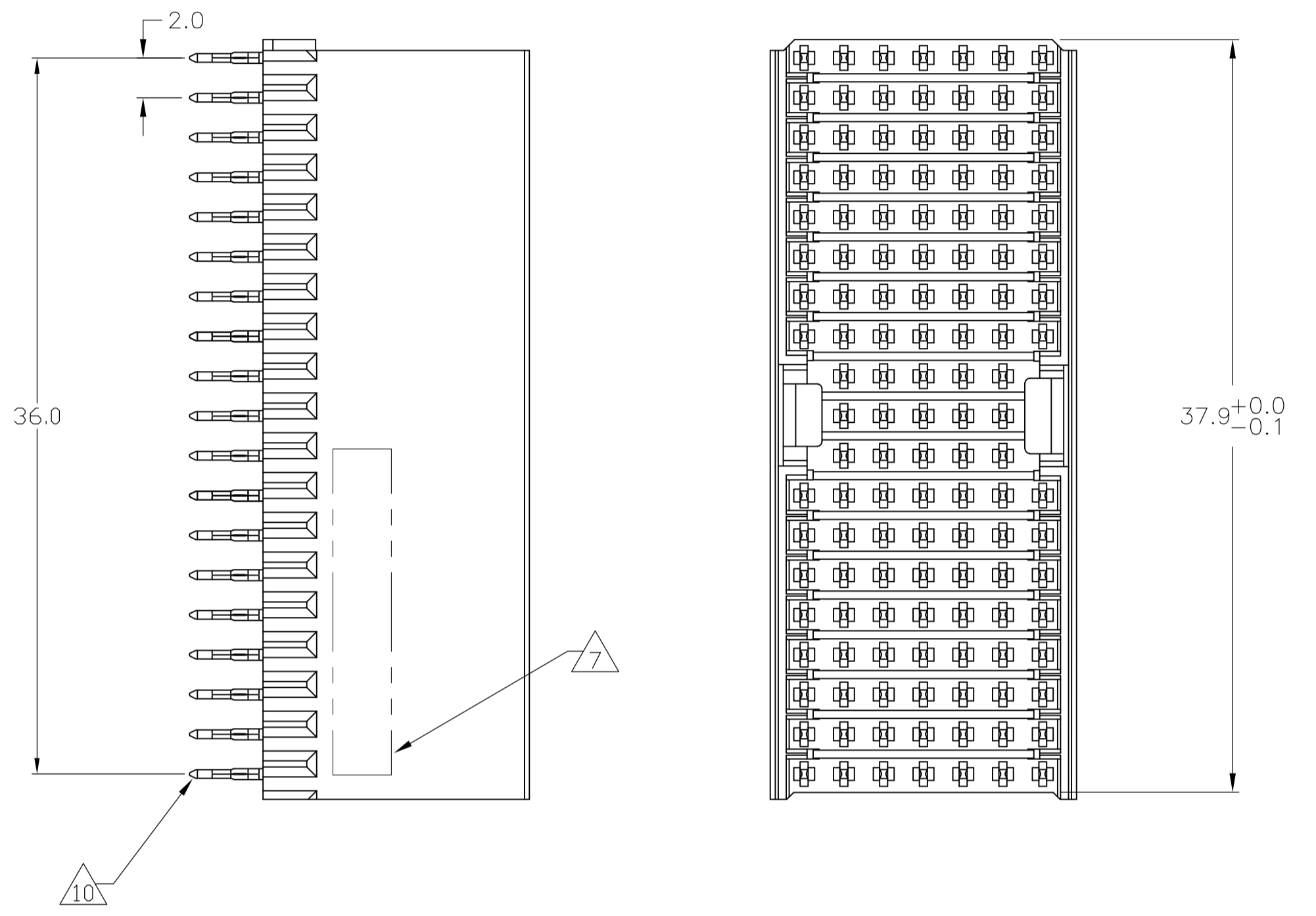
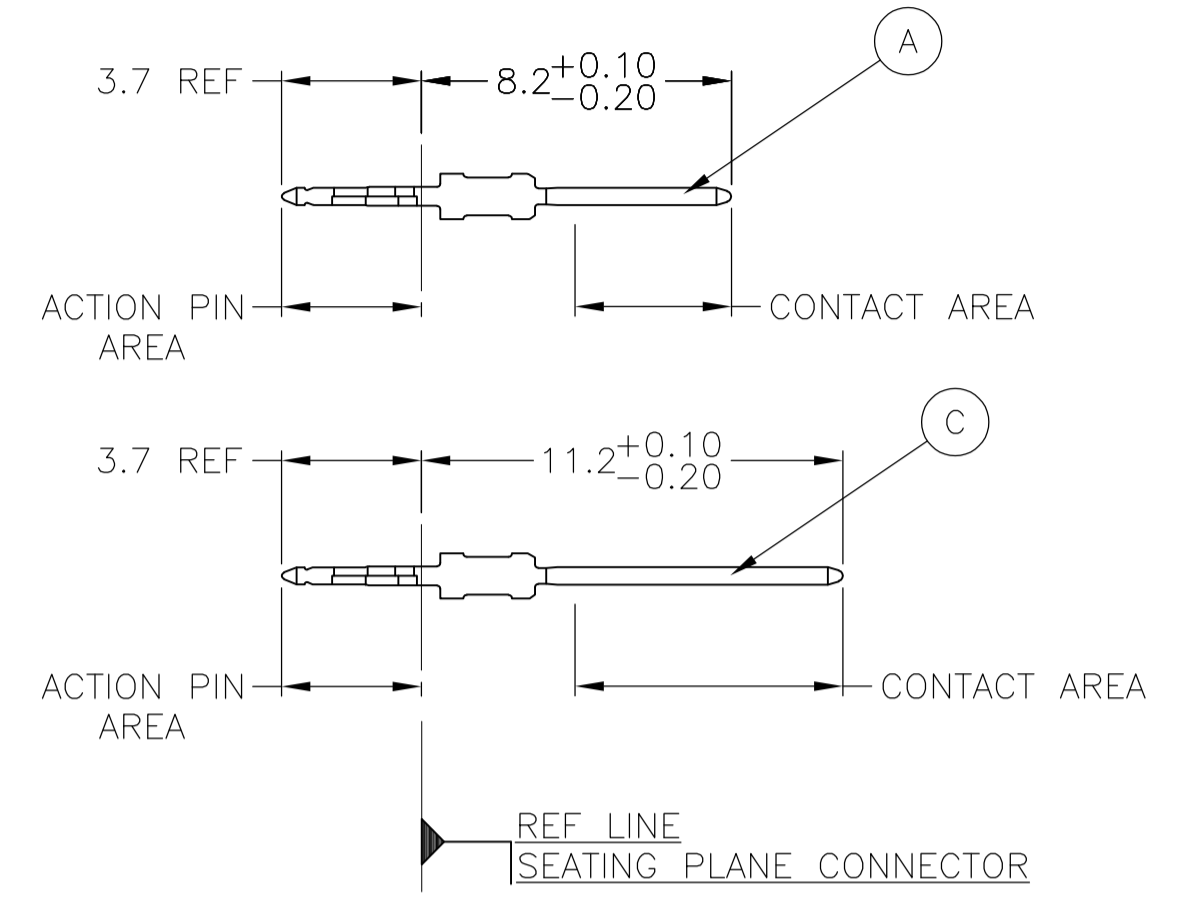

CONTACT LAYOUT

	z	a	b	c	d	e	f
1	C	A	A	A	A	A	C
2	C	A	A	A	A	A	C
3	C	A	A	A	A	A	C
4	C	A	A	A	A	A	C
5	C	A	A	A	A	A	C
6	C	A	A	A	A	A	C
7	C	A	A	A	A	A	C
8	C	A	A	A	A	A	C
9		A	A	A	A	A	
10		A	A	A	A	A	
11		A	A	A	A	A	
12	C	A	A	A	A	A	C
13	C	A	A	A	A	A	C
14	C	A	A	A	A	A	C
15	C	A	A	A	A	A	C
16	C	A	A	A	A	A	C
17	C	A	A	A	A	A	C
18	C	A	A	A	A	A	C
19	C	A	A	A	A	A	C

**RECOMMENDED PCB-HOLE LAYOUT
COMPONENT SIDE SHOWN**

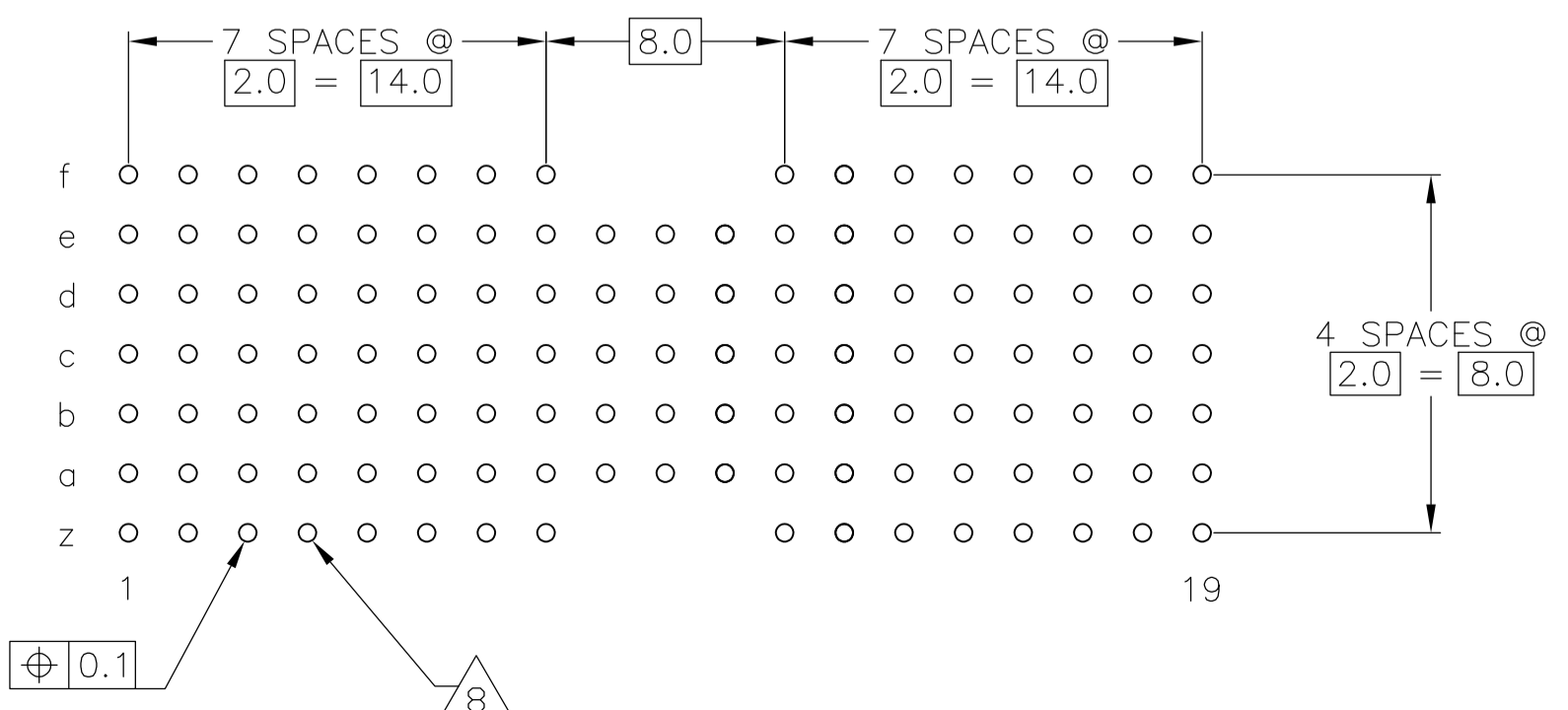

PLATED THRU HOLES PARAMETERS
REFERENCE APPLICATION SPECIFICATION

2 3 13	3-646530-0
2 6 12	1-646530-9
2 5 12	646530-9
2 4	646530-4
2 3	646530-1
OBSOLETE	
FINISH	PART NUMBER

THIS DRAWING IS A CONTROLLED DOCUMENT.

DIMENSIONS: mm	TOLERANCES UNLESS OTHERWISE SPECIFIED:	DIN B CARBO 07SEP05	Tyco Electronics Corporation Harrisburg, Pa 17105-3608
0-PLC ±	±0.2	CHK G SKIPPER 07SEP05	APVD G SKIPPER 07SEP05
1-PLC ±		NAME	MALE ASSEMBLY, Z-PACK 2mm HM, TYPE A/B
2-PLC ±		PRODUCT SPEC	108-19082
3-PLC ±		APPLICATION SPEC	114-19029
4-PLC ±		WEIGHT	A1 00779 C=646530
ANGLES	SEE TABLE	CUSTOMER DRAWING	SCALE 4:1 SHEET 1 OF 2 REV D

LOC		DIST		REVISIONS			
#	DATE	DESCRIPTION	DATE	OWN	APVD		
AD	00	SEE SHEET 1	-	-	-		

- 1 MATERIAL:
CONTACT: PHOSPHOR BRONZE.
HOUSING: GLASS-FILLED POLYESTER.
- 2 GENERAL PLATING SPECIFICATION: UNDERPLATING
(ENTIRE CONTACT): 1.27µm MIN NICKEL AND ACTION
PIN: 0.5µm MIN TIN/LEAD.
FOR PLATING OF MATING SURFACES SEE APPLICABLE
SPECIFICATION REFERENCE FOR EACH DASH NUMBER.
- 3 CONFORMS TO ALL TESTING ACCORDING TO IEC 61076-4-101
PERFORMANCE LEVEL 2.
- 4 CONFORMS TO ALL TESTING ACCORDING TO IEC 61076-4-101
PERFORMANCE LEVEL 1.
- 5 CONNECTOR TESTED AND QUALIFIED AGAINST TELCORDIA GR-1217-CORE QUALITY LEVEL 3,
CENTRAL OFFICE APPLICATIONS.
- 6 CONNECTOR TESTED AND QUALIFIED AGAINST TELCORDIA GR-1217-CORE QUALITY LEVEL 3,
UNCONTROLLED ENVIROMENT APPLICATIONS.
- 7 CONNECTOR MARKED WITH PART NUMBER AND DATE CODE.
ADDITIONAL CHARACTERS OR MARKINGS, AS WELL AS THE LOCATION OF THE MARKINGS,
MAY BE ADDED FOR TRACEABILITY BASED UPON MANUFACTURERS DISCRETION.
- 8 PLATED-THROUGH HOLES AT 2x2mm SQUARE GRID
PATTERN DEFINED BY CONTACT LAYOUT.
- 9 FOR ACTUAL PIN LOADING SEE "CONTACT LAYOUT".
- 10 FOR ACTUAL PIN DIMENSIONS SEE "CONTACT DIMENSIONS".
- 11 TO BE MEASURED AT BOTTOM OF SHROUD.
- 12 CONNECTOR LUBRICATED WITH BELCORE APPROVED LUBRICANT,
TECHNICAL REFERENCE: TR-NWT-001217 ISSUE 1, SEP 1992.
- 13 0.76µm MIN. GOLD PLATING AT MATING SURFACES.

THIS DRAWING IS A CONTROLLED DOCUMENT.		DWN E CARBO 07SEP05	Tyco Electronics Corporation Harrisburg, Pa 17105-3608	
DIMENSIONS: mm		CHK G SKIPPER 07SEP05	NAME MALE ASSEMBLY, Z-PACK 2mm HM, TYPE A/B	
TOLERANCES UNLESS OTHERWISE SPECIFIED:		APVD G SKIPPER 07SEP05	RESTRICTED TO	
0-PLC ±		PRODUCT SPEC	SIZE	
1-PLC ±0.1		108-19082	CAGE CODE	
2-PLC ±		APPLICATION SPEC	DRAWING NO	
3-PLC ±		114-19029	A1 00779	
4-PLC ±		WEIGHT	C=646530	
ANGLES ±		—	SCALE 4:1	
MATERIAL SEE SHEET 1	FINISH SEE SHEET 1	CUSTOMER DRAWING	SHEET 2 OF 2	
			REV D	

X-ON Electronics

Largest Supplier of Electrical and Electronic Components

Click to view similar products for [Hard Metric Connectors](#) category:

Click to view products by [TE Connectivity](#) manufacturer:

Other Similar products are found below :

[10146110-VR5C](#) [6345127-1](#) [646916-9](#) [6469658-1](#) [853016](#) [973108](#) [1-2000713-0](#) [1-2000713-2](#) [1-2000713-3](#) [120646-1](#) [134187](#) [1645343-1](#)
[1645456-1](#) [1645564-3](#) [1645594-1](#) [1645601-1](#) [1934822-1](#) [2000829-2](#) [2000985-2](#) [223085-1](#) [278071110010833](#) [1645179-1](#) [1645245-1](#)
[1645457-1](#) [1645525-1](#) [1645570-1](#) [1645596-1](#) [17-8072-125-000-863+](#) [1857470-1](#) [1934275-1](#) [1934289-1](#) [1934759-1](#) [2000673-1](#) [2000843-2](#)
[2000984-2](#) [204975](#) [2170292-2](#) [2-536642-6](#) [3-100668-0](#) [3-106015-1](#) [352188-1](#) [352629-1](#) [3-646346-0](#) [3-646356-0](#) [3-646457-0](#) [3-646529-0](#) [3-646530-0](#) [5120823-1](#) [5120899-1](#) [5120948-1](#)