

SAFETY ORGANIZATION(S),

THIS FILTER HAS BEEN FORMALLY RECOGNIZED, CERTIFIED OR APPROVED BY THE LISTED AGENCY. THEREFORE, ALL TEST/REQUIREMENTS SPECIFIED IN THE LATEST REVISION OF THE FOLLOWING AGENCY STANDARDS HAVE BEEN MET:

UL RECOGNIZED	UL 1283
CSA CERTIFIED	CSA 22.2, NO.0,0.4,8
VDE APPROVED	VDE 565-3, 625

OPERATING SPECIFICATIONS,

LINE VOLTAGE/CURRENT, 3 AMP., 120/250 VAC
2 AMP./40°C, 250 VAC

LINE FREQUENCY, 50-60Hz
MAX. LEAKAGE CURRENT, EACH
LINE TO GROUND .3mA @ 120V 60Hz
.5mA @ 250V 50Hz
OPERATING AMBIENT TEMP. RANGE, -10°C TO +40°C @ RATED CURRENT, I_r

IN AN AMBIENT, T_a, HIGHER THAN 40°C, THE MAXIMUM OPERATING CURRENT, I_o, IS AS FOLLOWS:

$$I_o = I_r \sqrt{\frac{85 - T_a}{45}}$$

RELIABILITY SPECIFICATIONS,

STORAGE TEMPERATURE, -25°C TO +85°C
HUMIDITY, 21 DAYS @ 40°C 95% RH
CURRENT OVERLOAD TEST, 6 TIMES RATED CURRENT FOR 8 SECONDS

TEST SPECIFICATIONS,

INDUCTANCE, 2.3mH NOMINAL
CAPACITANCE, (MEASURED @ 1 KHz, 0.25 VAC MAX., 25°C ±1°C)
LINE TO GROUND, .004μF ±20%
LINE TO LINE, .37μF ±20%
DISCHARGE RESISTOR, 820KΩ
LINE/GROUND AND LINE/LINE 6000 MΩ (MIN) AT 100 VDC
INSULATION RESISTANCE 20°C AND 50% RH (W/O DISCHARGE RESISTOR)

RECOMMENDED RECEIVING INSPECTION HIPOT,

LINES TO GROUND, 1500 VAC FOR 1 MINUTE
LINE TO LINE, 1450 VDC FOR 1 MINUTE

FILTER APPROVAL,

THE BEST WAY TO SELECT AND QUALIFY A FILTER IS FOR YOUR ENGINEERING TO TEST THE UNIT IN YOUR EQUIPMENT.

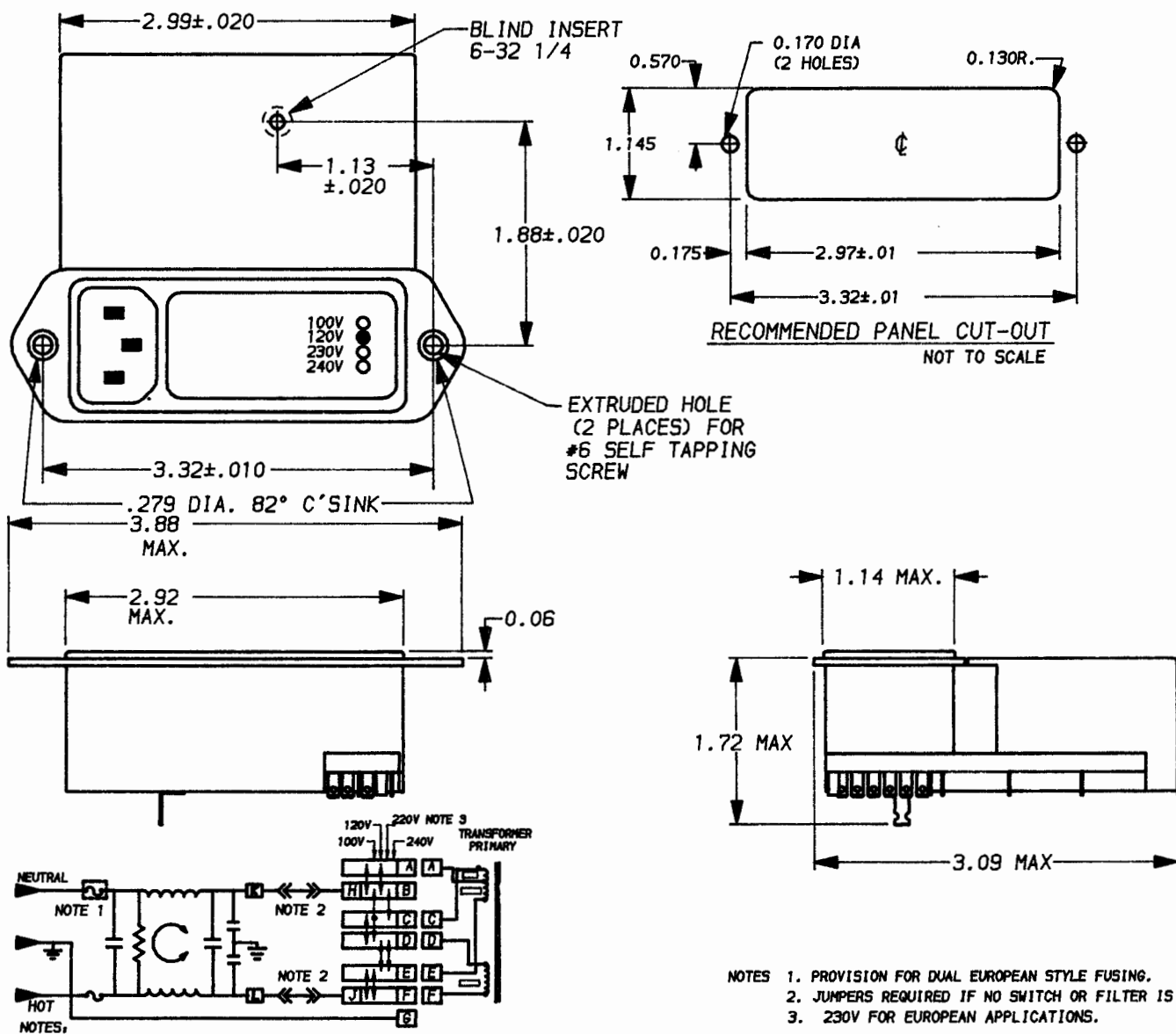

50Ω - 50Ω (MINIMUM) INSERTION LOSS									
FREQUENCY MHz	.01	.05	.07	.15	.50	1.0	5	10	30
COMMON dB	2	13	16	23	40	46	44	44	44
DIFF. dB	—	—	5	34	62	68	60	50	40

UNLESS OTHERWISE SPECIFIED, TOLERANCE TO BE ±.025
MATERIAL & FINISH, AS SUPPLIED
This document is proprietary to CORCOM INC. and is not to be reproduced nor used for manufacturing purposes except on CORCOM'S prior written consent.

corcom
LIBERTYVILLE, IL 60048

POWER LINE FILTER

DATE: 4-18-94 CATALOG NO. REV. 3EXM4 02
APPRVD.

CAD NO. 3EXM4.02

X-ON Electronics

Largest Supplier of Electrical and Electronic Components

Click to view similar products for [AC Power Entry Modules](#) category:

Click to view products by [TE Connectivity](#) manufacturer:

Other Similar products are found below :

[0098.0050](#) [6167.0002](#) [6609100-2](#) [7-6609955-2](#) [FKI2-50-6/M5](#) [FN361-6-06](#) [FN389-4-22](#) [FN9226B-6-02](#) [FN9233S1-10-06](#) [FN9233S1-8-06](#)
[FN9233S1B-8-06](#) [FN9233S1R-1-06](#) [FN9233S1R-12-06](#) [FN9233SB-1-06](#) [FN9233SB-12-06](#) [FN9233SB-8-06](#) [FN9233SR-10-06](#) [FN9244B-15-06HI](#) [FN9244EB-3-06](#) [FN9244EB-8-06](#) [FN9244ER-15-06](#) [FN9244ER-8-06](#) [FN9244ES1-8-06](#) [FN9244ESB-8-06](#) [FN9244R-12-06](#)
[FN9244S1-12-06](#) [FN9244S1R-3-06](#) [FN9244SB-8-06](#) [FN9244SR-6-06](#) [FN9244U-3-06](#) [FN9244U-8-06](#) [8-6609940-2](#) [PE00SSSXB](#) [Fuse-H-EUR-1](#) [Fuse-H-USA-1](#) [PM00XD000](#) [A-0701-HT-H](#) [15EJMS8](#) [1-6609941-2](#) [200JM6-2](#) [CA121003-6](#) [SK-1015\(F1-5\)](#) [161-R3015-E](#) [1-6609153-2](#) [FN323-1-05](#) [FN9233B-8-06](#) [FN9233EB-1-06](#) [FN9233ES1R-10-06](#) [FN9233R-12-06](#) [FN9233S-10-06](#)