

LOC	DIST	REVISIONS					
		P	LTN	DESCRIPTION	DATE	DWN	APVD
		A		RELEASE	30DEC2015	JY	SH
		B		REVISED PER ECO-19-016043	21OCT2019	SH	SH

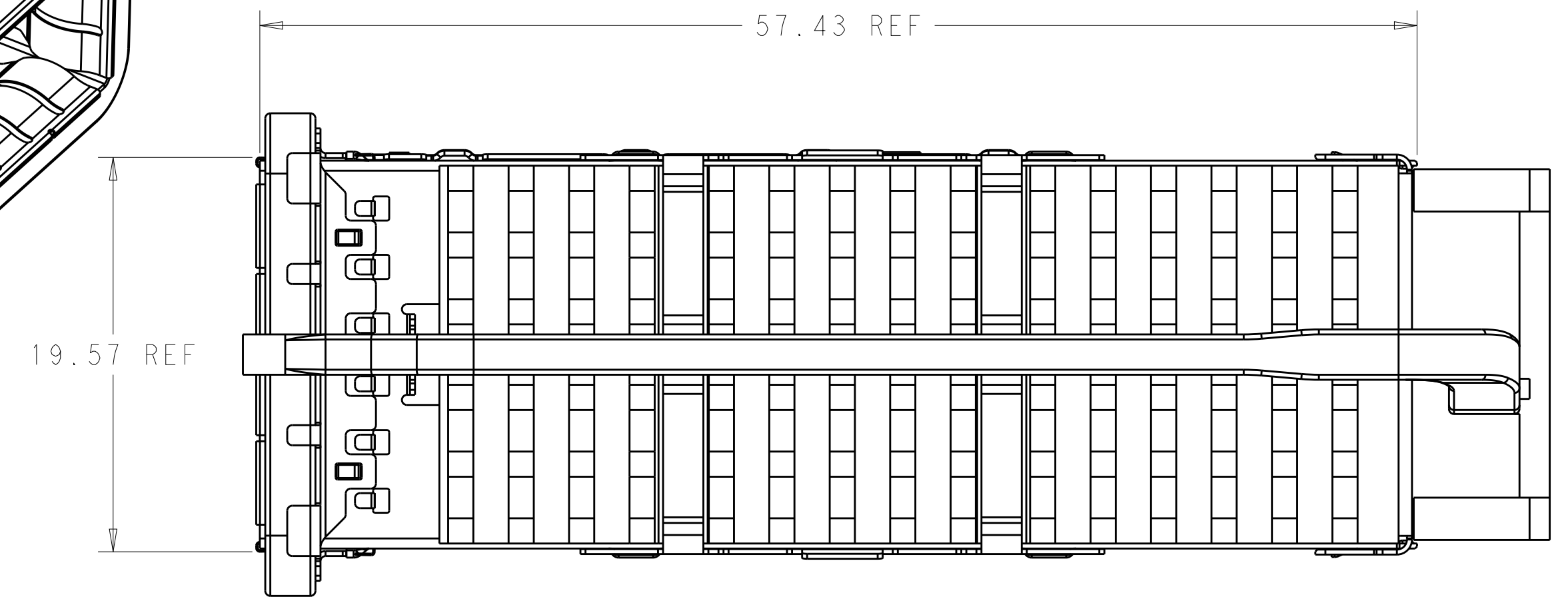
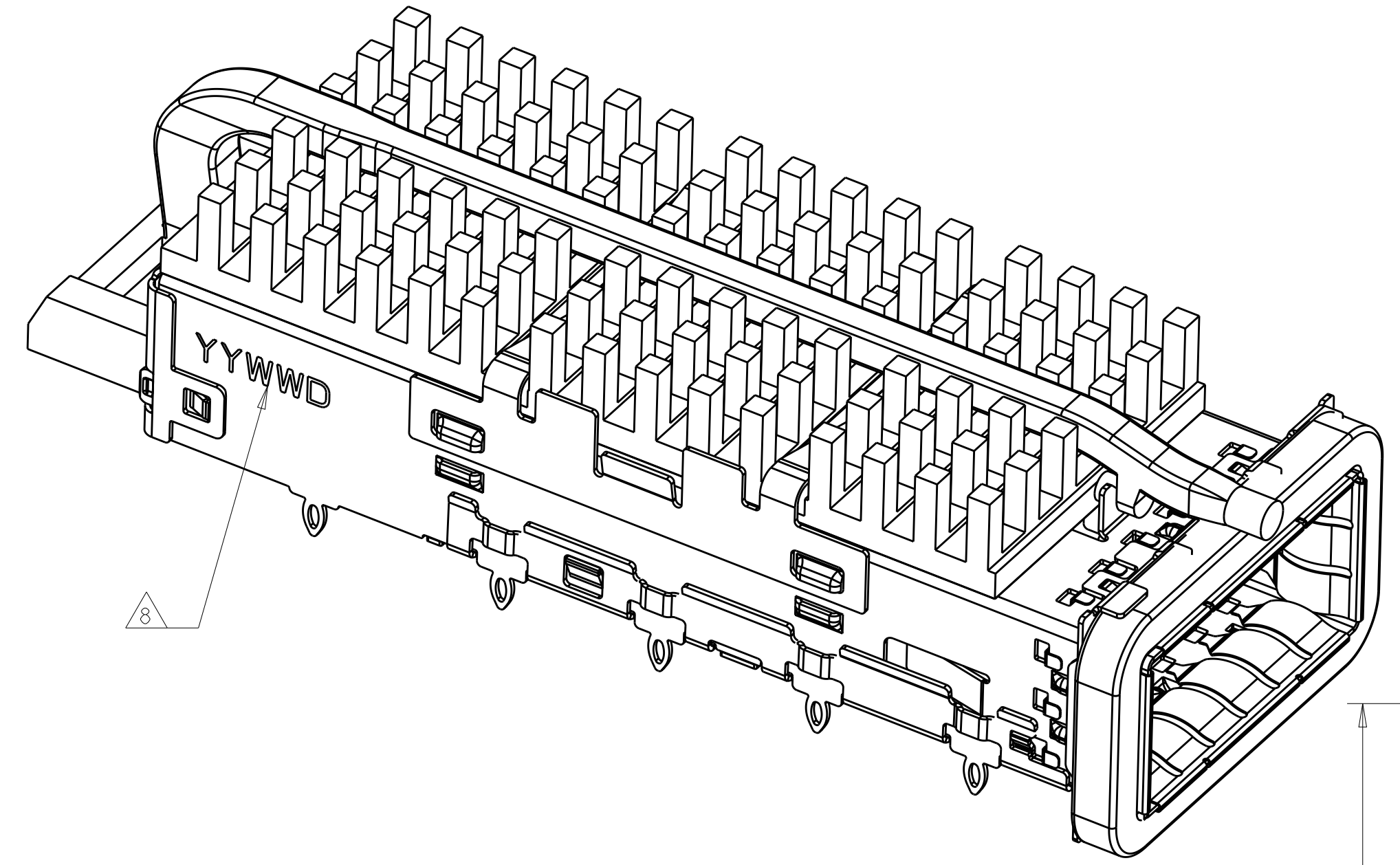

1. MATERIAL:  
 CAGE MATERIAL : 0.25 THICK NICKEL SILVER.  
 SPRING MATERIAL : COPPER ALLOY  
 HEAT SINK MATERIAL : ALUMINUM  
 CLIP MATERIAL : STAINLESS STEEL  
 LIGHT PIPE : POLYCARBONATE WITH 94 V-0  
 EMI GASKET : PLATED FILLED SILICONE  
 ORGANIZER MATERIAL : POLYESTER WITH 94 V-0

2. FINISH:  
 SPRING : NICKEL PLATING  
 HEAT SINK : BLACK ANODIZE

3. DIMENSION APPLIES WITH MODULE INSTALLED IN THE CAGE TO TOP OF HEAT SINK.

4. REFERENCE APPLICATION SPEC 114-32023 FOR RECOMMENDED DRILL HOLE DIAMETER AND PLATING THICKNESS.

5. DATUM AND BASIC DIMENSIONS ESTABLISHED BY CUSTOMERS.

6. MINIMUM PC BOARD THICKNESS :  
 SINGLES SIDED : 1.57 MIN  
 DOUBLE SIDED : 3.00 MIN

7. DATUM -A- IS TOP SURFACE OF THE HOST BOARD.

8. DATE CODE (YYWWD) MARKED APPROXIMATELY AS SHOWN

9. MATES WITH QSFP28 MSA COMPATIBLE TRANSCEIVER.

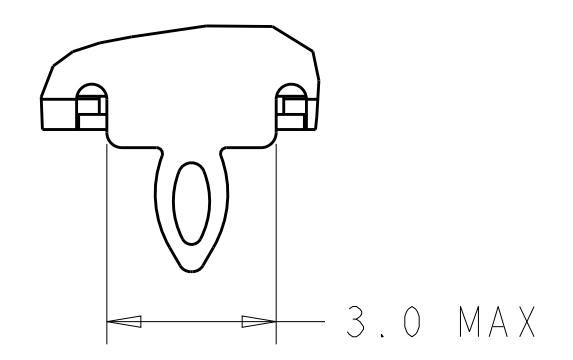
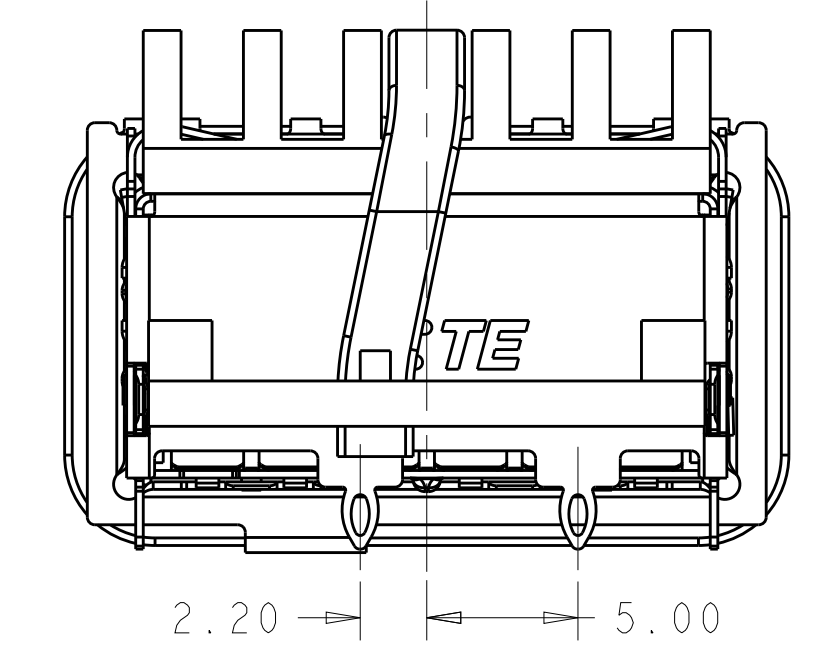
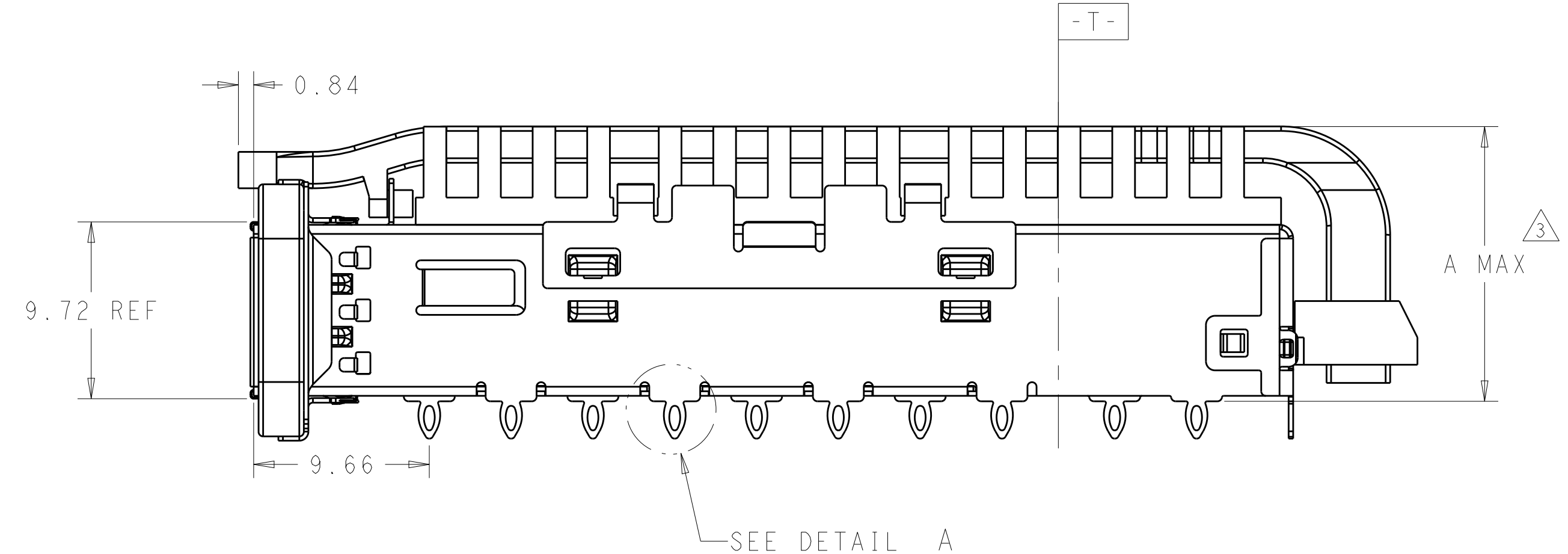
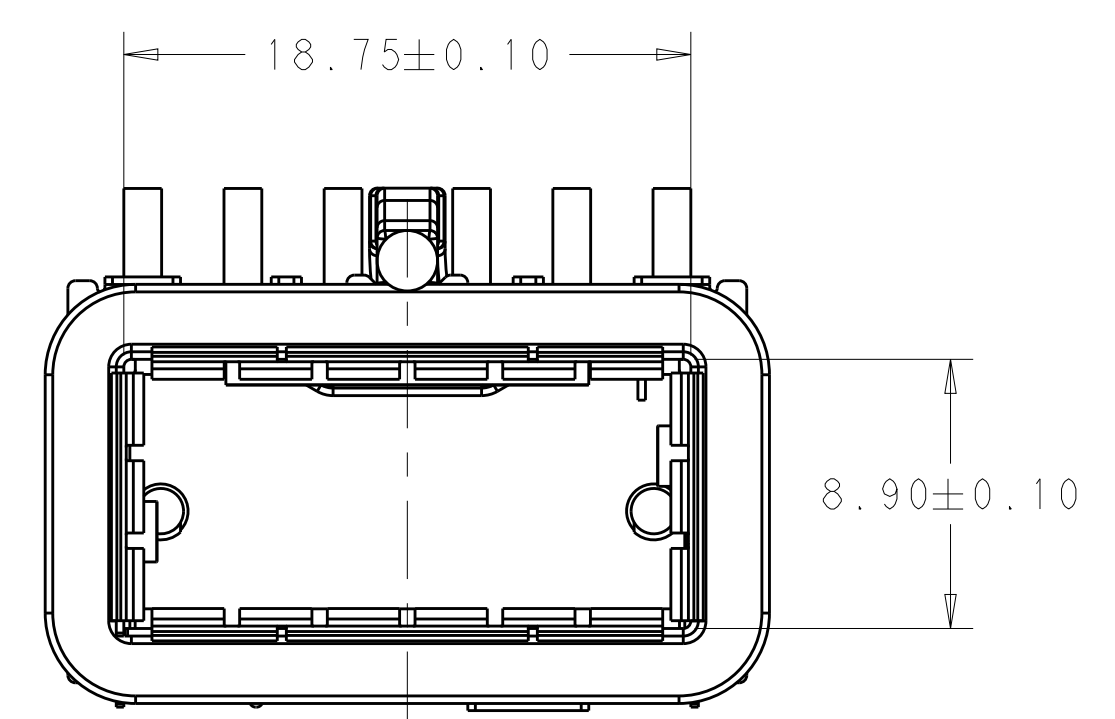

DETAIL A  
SCALE 8:1

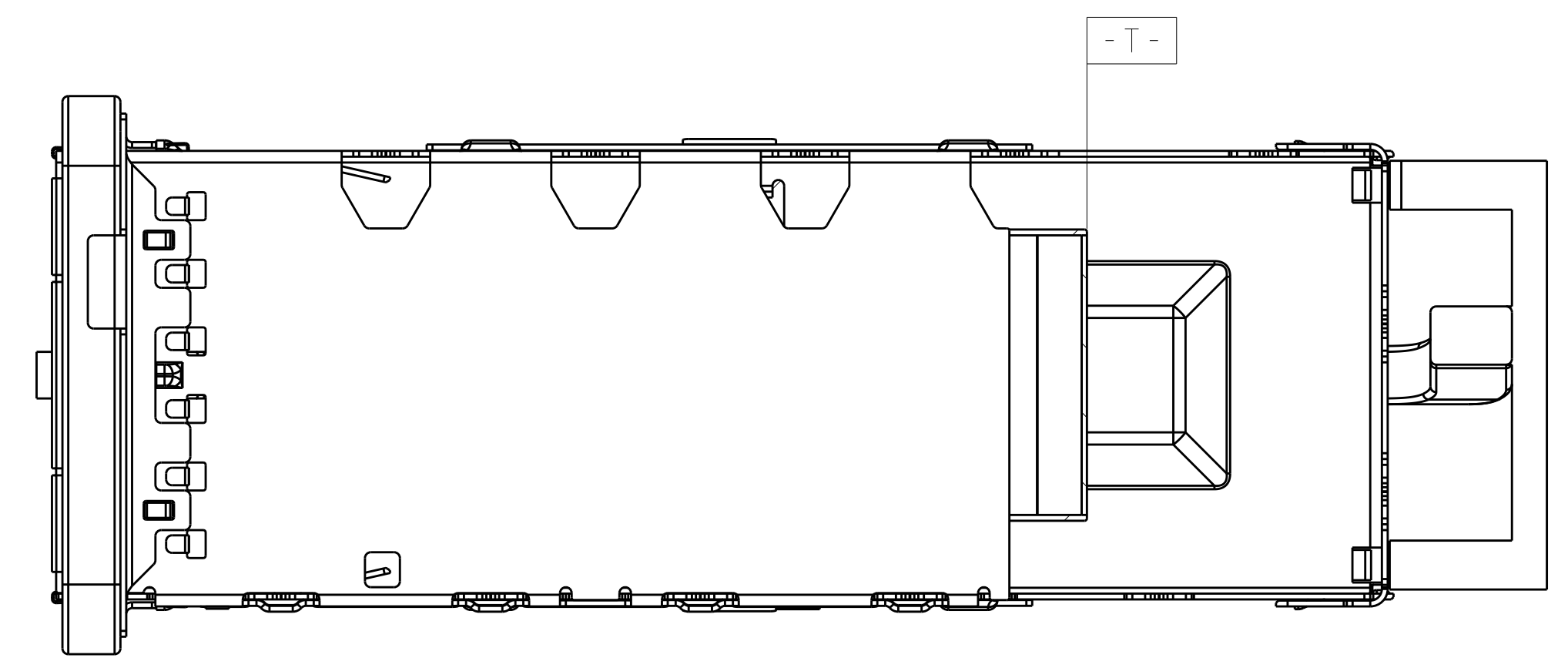

2170754-2 AS SHOWN

THIS DRAWING IS A CONTROLLED DOCUMENT.		DWN: JASON YANG 01APR2014	TE Connectivity
		CHK: SEAN HAN 30DEC2015	
DIMENSIONS:		NAME	
TOLERANCES UNLESS OTHERWISE SPECIFIED:		CAGE ASSEMBLY, QSFP28 1X1, THRU BEZEL, WITH EMI GASKET, HEAT SINK, LIGHT PIPE	
mm	0 PLC ±0.25	PRODUCT SPEC	RESTRICTED TO
	1 PLC ±0.25	108-19428	
	2 PLC ±0.20	APPLICATION SPEC	
	3 PLC ±0.100	114-32023	
	4 PLC ±	WEIGHT	
	ANGLES	CUSTOMER DRAWING	
	FINISH	SCALE 2:1	SHEET 1 OF 7
		REV B	

LOC		DIST		REVISIONS			
P	LYR	DESCRIPTION	DATE	OWN	APVD		
-	-	SEE SHEET 1	-	-	-		

# HEAT SINK OPTIONS

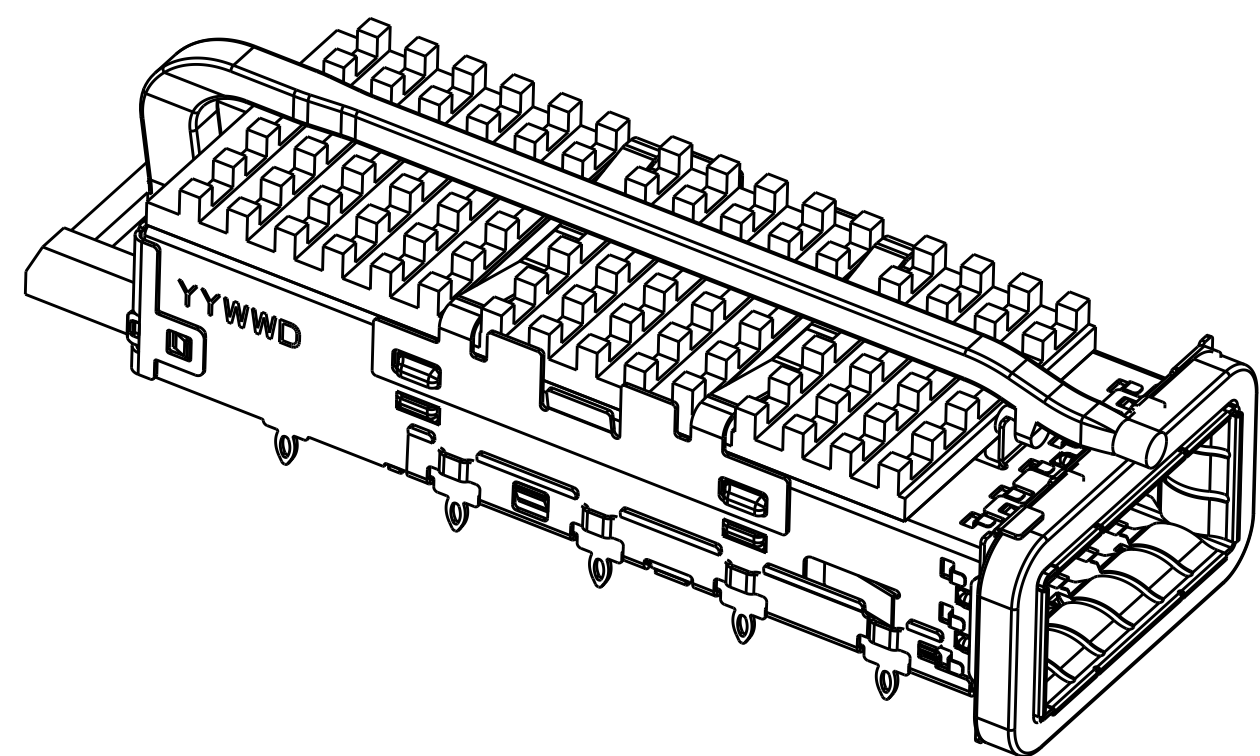

PCI HEAT SINK  
SCALE 5:2

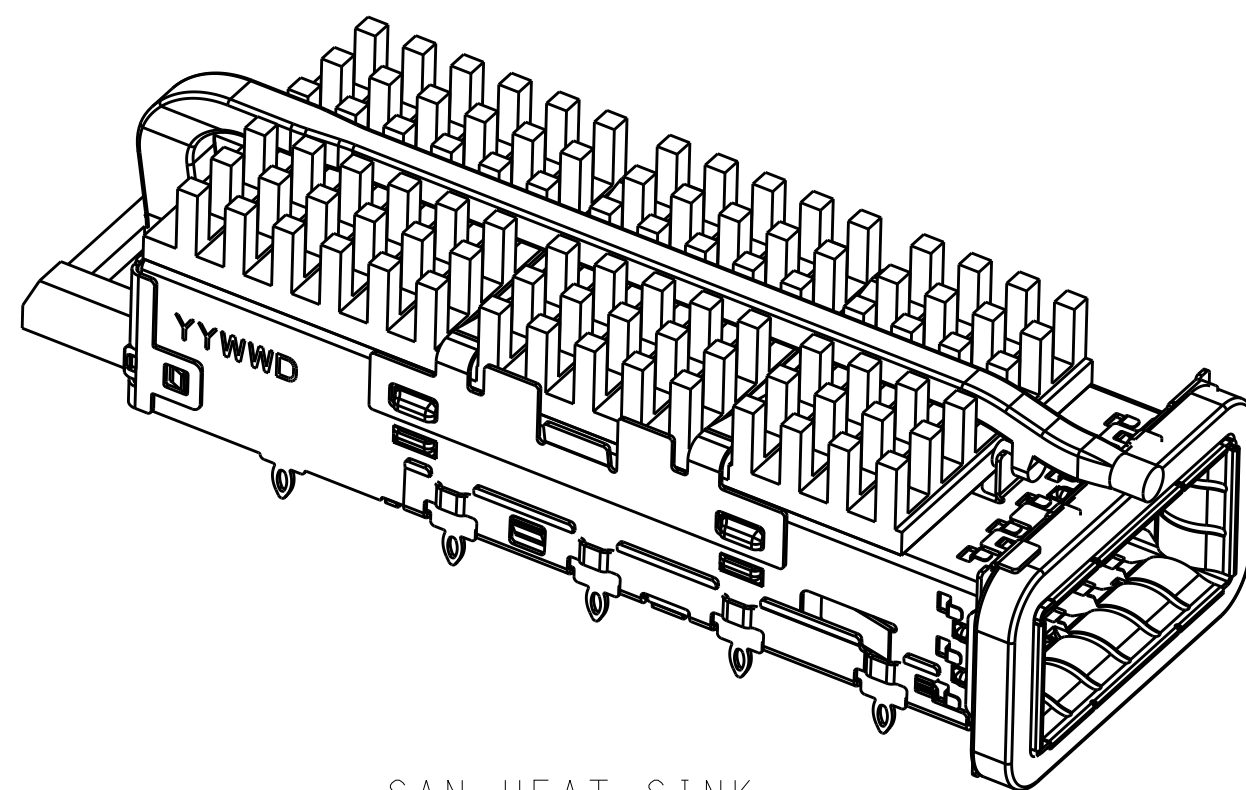

SAN HEAT SINK  
SCALE 5:2

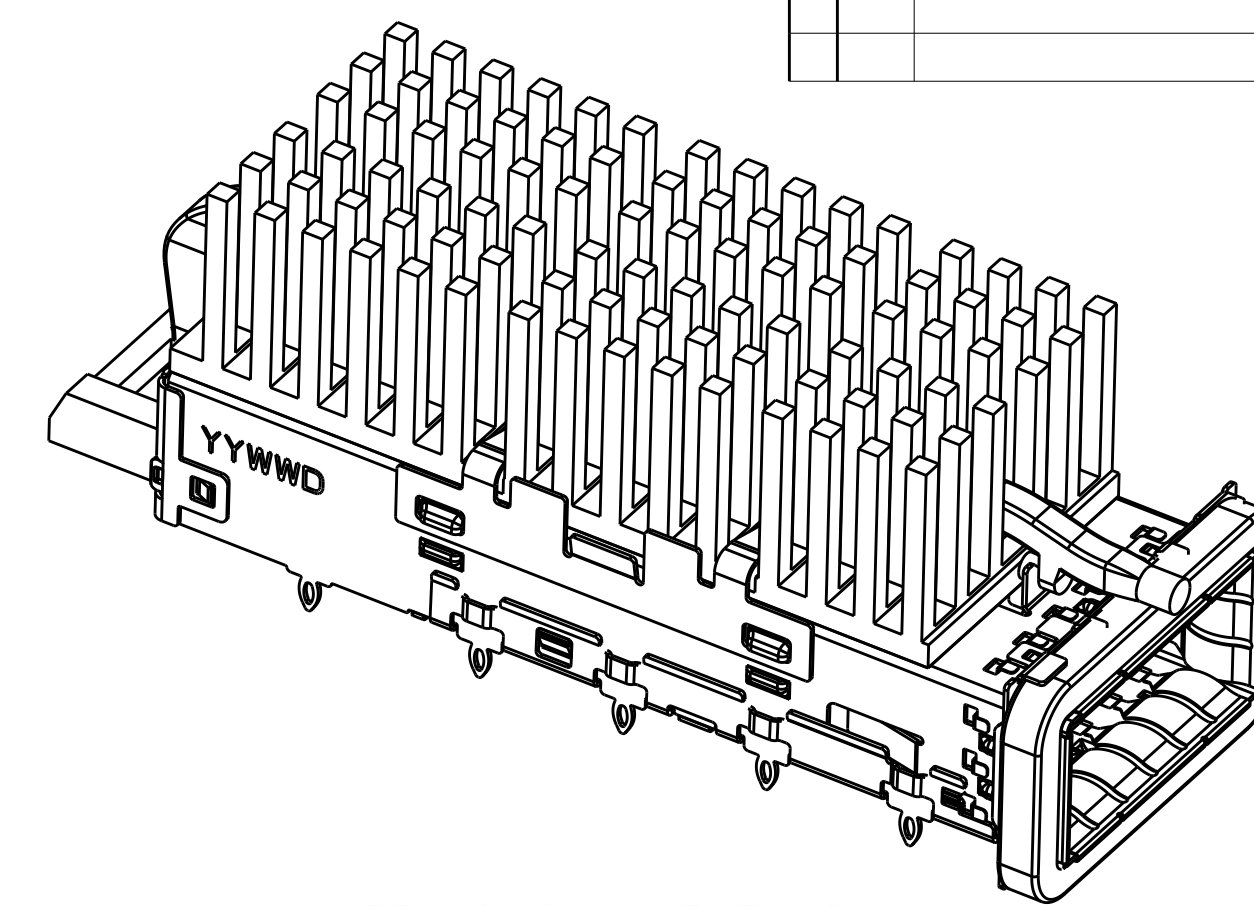

NETWORKING HEAT SINK  
SCALE 5:2

# # OF REAR LEGS OPTIONS

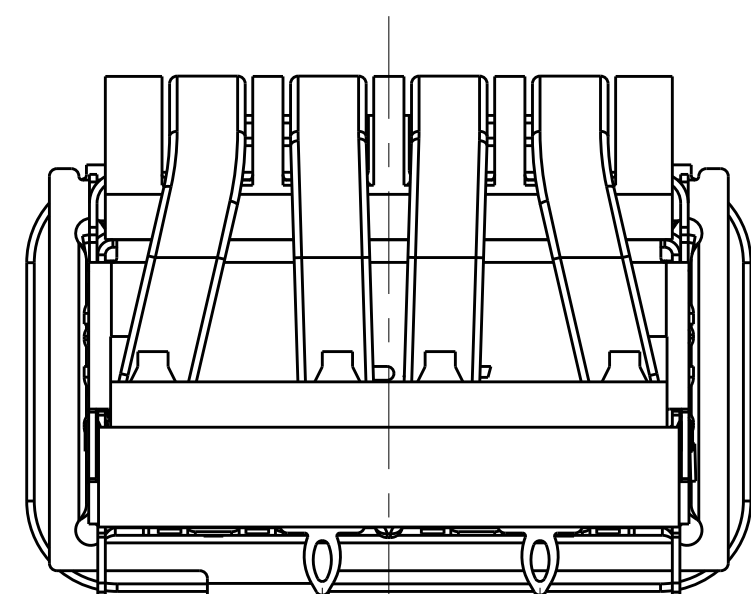

(2.20) (5.00)

2 REAR LEGS  
SCALE 4:1

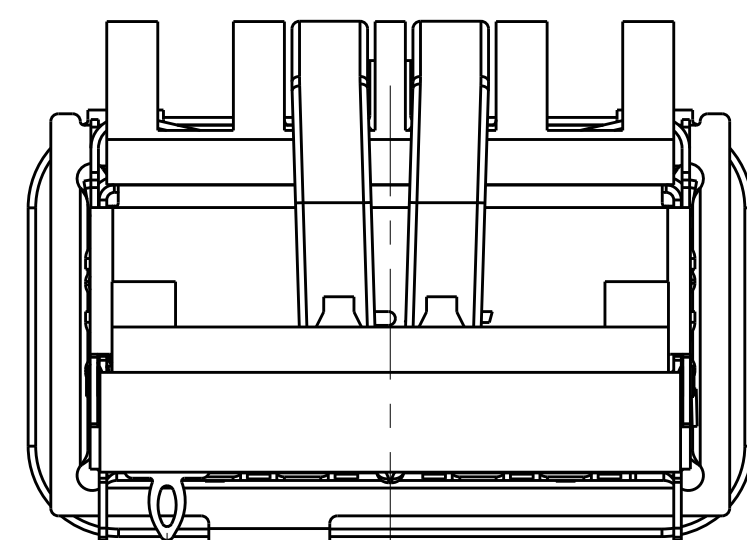

7.38

1 REAR LEG  
SCALE 4:1

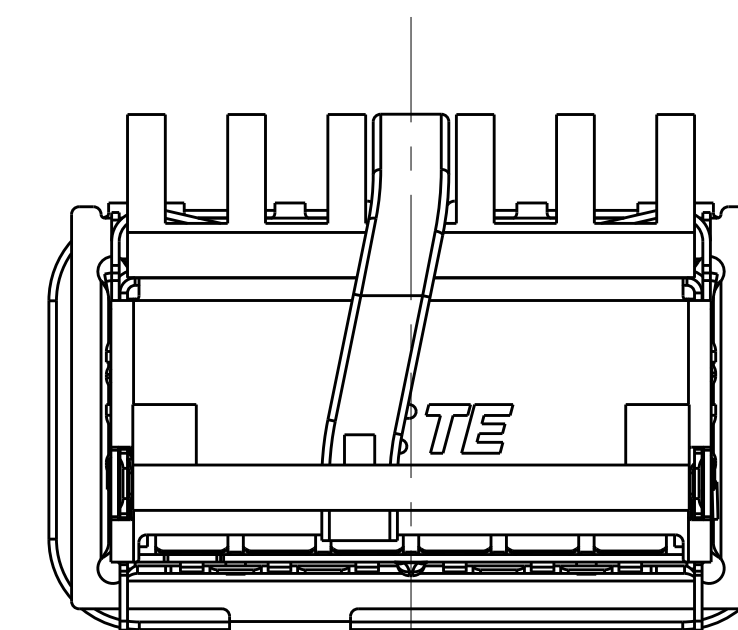

0 REAR LEG  
SCALE 4:1

# LIGHT PIPE OPTIONS

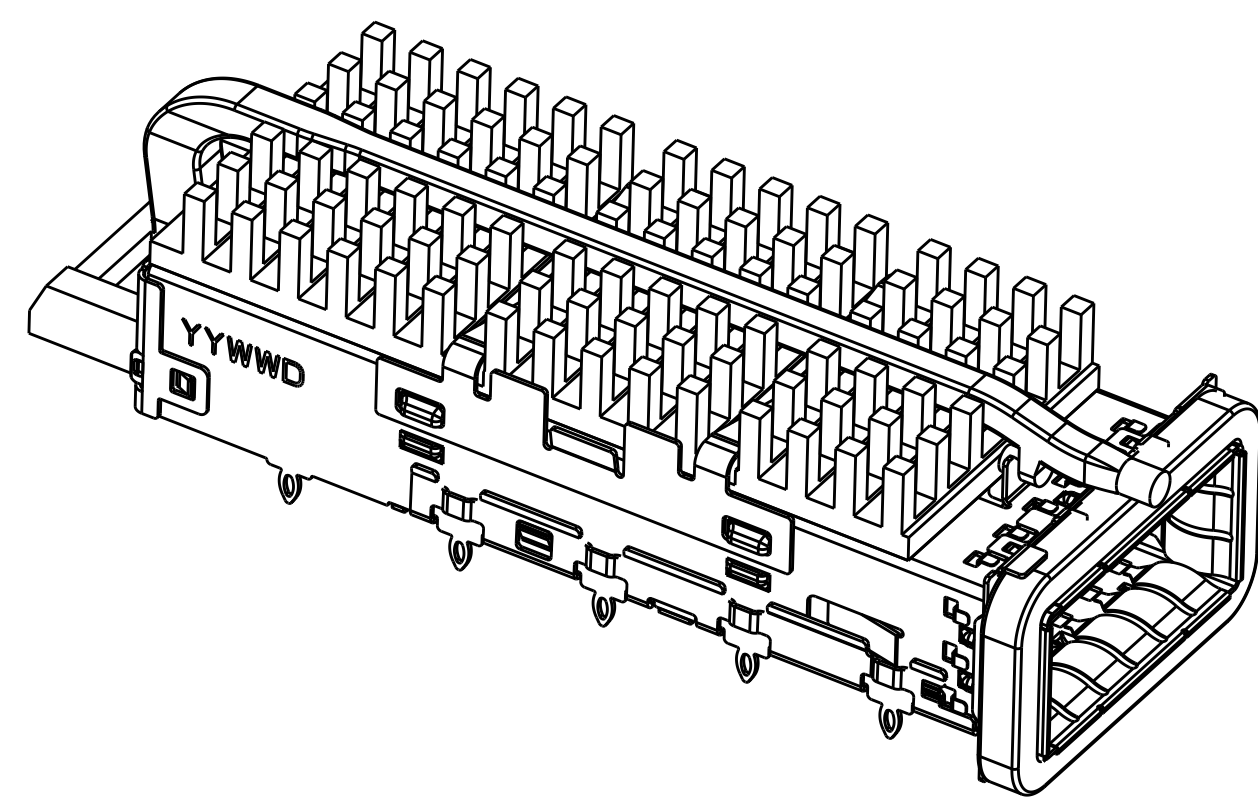

SINGLE LIGHT PIPE  
SCALE 5:2

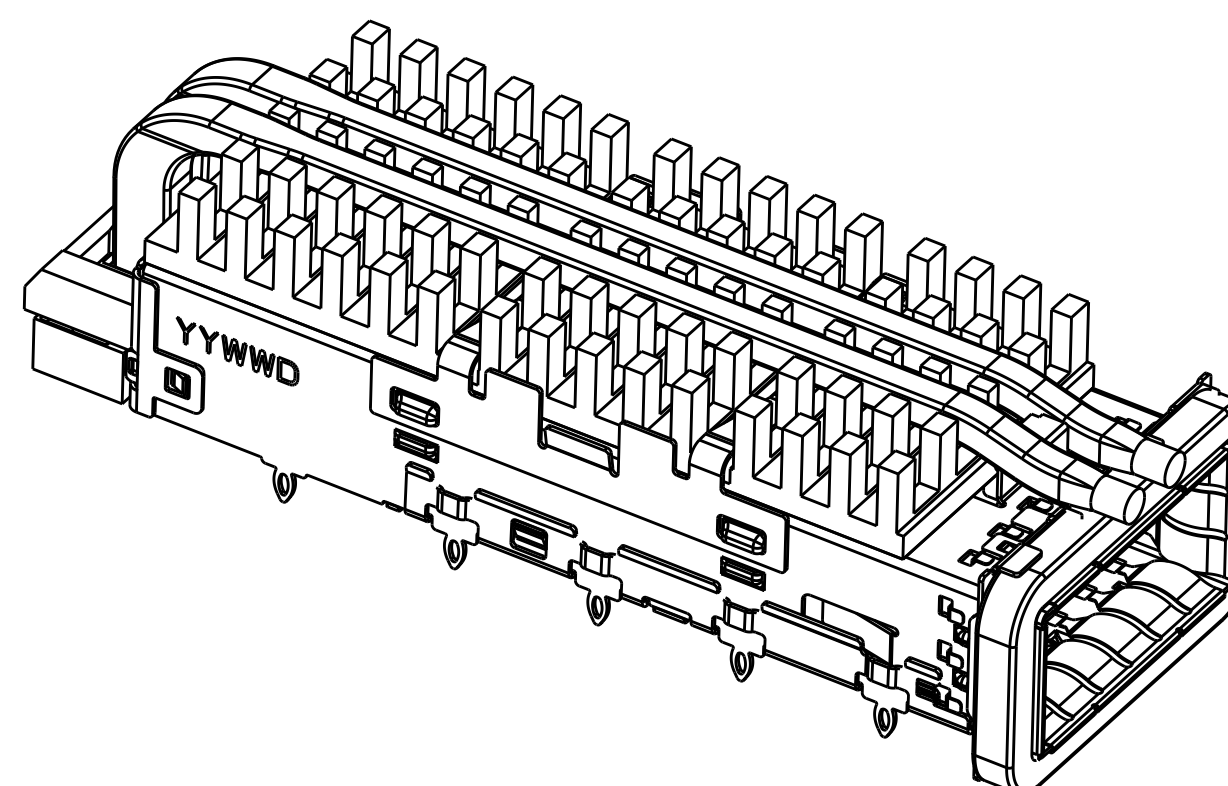

DUAL LIGHT PIPE  
SCALE 5:2

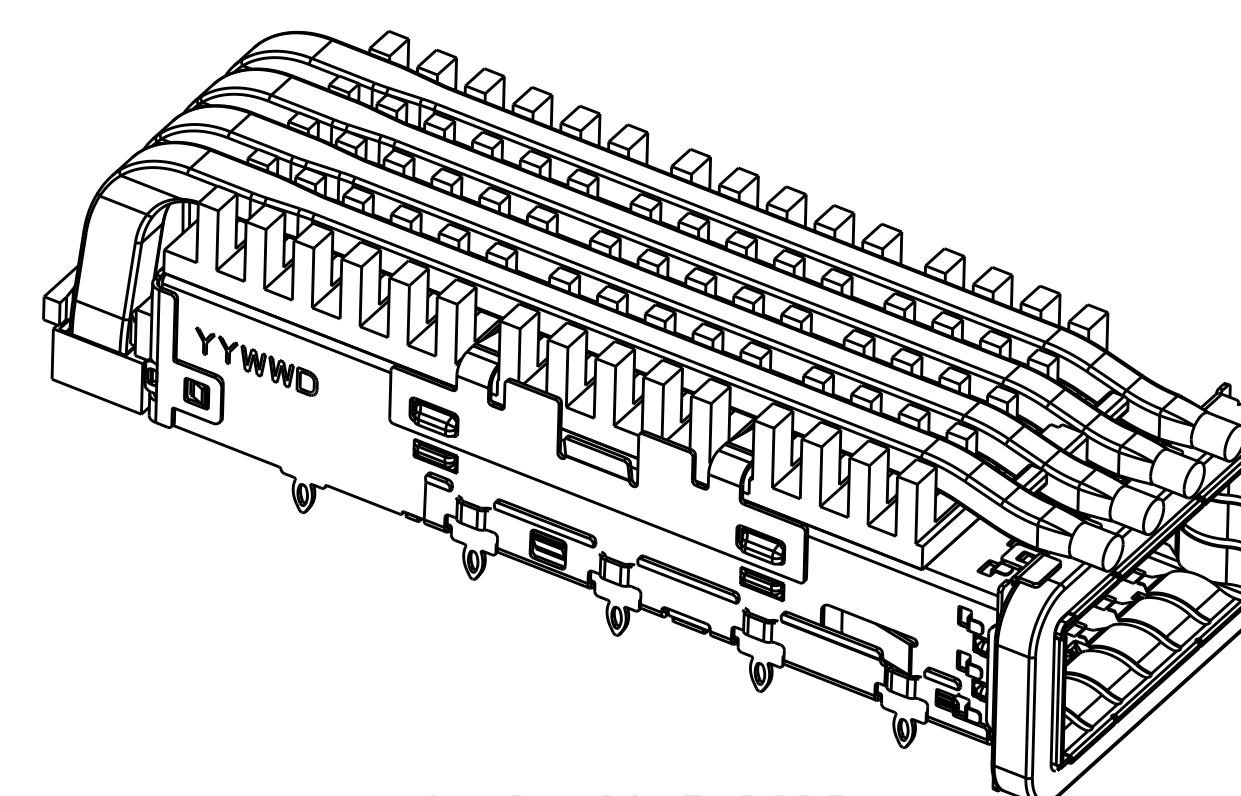

QUAD LIGHT PIPE  
SCALE 5:2

THIS DRAWING IS A CONTROLLED DOCUMENT.		OWN: JASON YANG 01APR2014	
		CHK: SEAN HAN 30DEC2015	
DIMENSIONS:		NAME: CAGE ASSEMBLY, QSFP28 1X1, THRU BEZEL, WITH EMI GASKET HEAT SINK, LIGHT PIPE	
mm	0 PLC ±0.25 1 PLC ±0.25 2 PLC ±0.25 3 PLC ±0.25 4 PLC ±0.100 ANGLES ±°	PRODUCT SPEC: 108-19428	RESTRICTED TO:
MATERIAL:		APPLICATION SPEC: 114-32023	SIZE: A100779
		WEIGHT: Customer Drawing	CAGE CODE: C=2170754
		SCALE: 4:1	SHEET 2 OF 7
			REV B

LOC	DIST	REVISIONS			
P	LTN	DESCRIPTION	DATE	DMN	APVD
-	-	SEE SHEET 1	-	-	-

0	16.0	WITHOUT	SINGLE	1-2170754-0
1	23.0	NETWORKING	QUAD	4-2170754-9
1	16.0	SAN	QUAD	4-2170754-8
1	13.7	PCI	QUAD	4-2170754-7
0	23.0	NETWORKING	QUAD	4-2170754-6
0	16.0	SAN	QUAD	4-2170754-5
0	13.7	PCI	QUAD	4-2170754-4
2	23.0	NETWORKING	QUAD	4-2170754-3
2	16.0	SAN	QUAD	4-2170754-2
2	13.7	PCI	QUAD	4-2170754-1
1	23.0	NETWORKING	DUAL	2-2170754-9
1	16.0	SAN	DUAL	2-2170754-8
1	13.7	PCI	DUAL	2-2170754-7
0	23.0	NETWORKING	DUAL	2-2170754-6
0	16.0	SAN	DUAL	2-2170754-5
0	13.7	PCI	DUAL	2-2170754-4
2	23.0	NETWORKING	DUAL	2-2170754-3
2	16.0	SAN	DUAL	2-2170754-2
2	13.7	PCI	DUAL	2-2170754-1
1	23.0	NETWORKING	SINGLE	2170754-9
1	16.0	SAN	SINGLE	2170754-8
1	13.7	PCI	SINGLE	2170754-7
0	23.0	NETWORKING	SINGLE	2170754-6
0	16.0	SAN	SINGLESINGLE	2170754-5
0	13.7	PCI	SINGLE	2170754-4
2	23.0	NETWORKING	SINGLE	2170754-3
2	16.0	SAN	SINGLE	2170754-2
2	13.7	PCI	SINGLE	2170754-1
# REAR PINS	DIM A	APPLICATION (HEAT SINK OPTION)	LIGHT PIPE OPTION	PART NUMBER

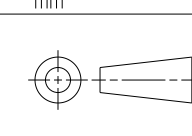
THIS DRAWING IS A CONTROLLED DOCUMENT.		DMN JASON YANG CHK SEAN HAN	01APR2014 30DEC2015	 TE Connectivity
DIMENSIONS: mm		TOLERANCES UNLESS OTHERWISE SPECIFIED: 0 PLC ±0.25 1 PLC ±0.25 2 PLC ±0.25 3 PLC ±0.100 4 PLC ±0.100 ANGLES ±°		
		PRODUCT SPEC 108-19428 APPLICATION SPEC 114-32023		NAME CAGE ASSEMBLY, QSFP28 1X1, THRU BEZEL, WITH EMI GASKET HEAT SINK, LIGHT PIPE
MATERIAL		WEIGHT		SIZE A100779C=2170754
-		-		RESTRICTED TO Customer Drawing SCALE 4:1 SHEET 3 OF 7 REV B

LOC		DIST		REVISIONS			
P	LTN	DESCRIPTION	DATE	DWN	APVD		
-	-	SEE SHEET 1	-	-	-		

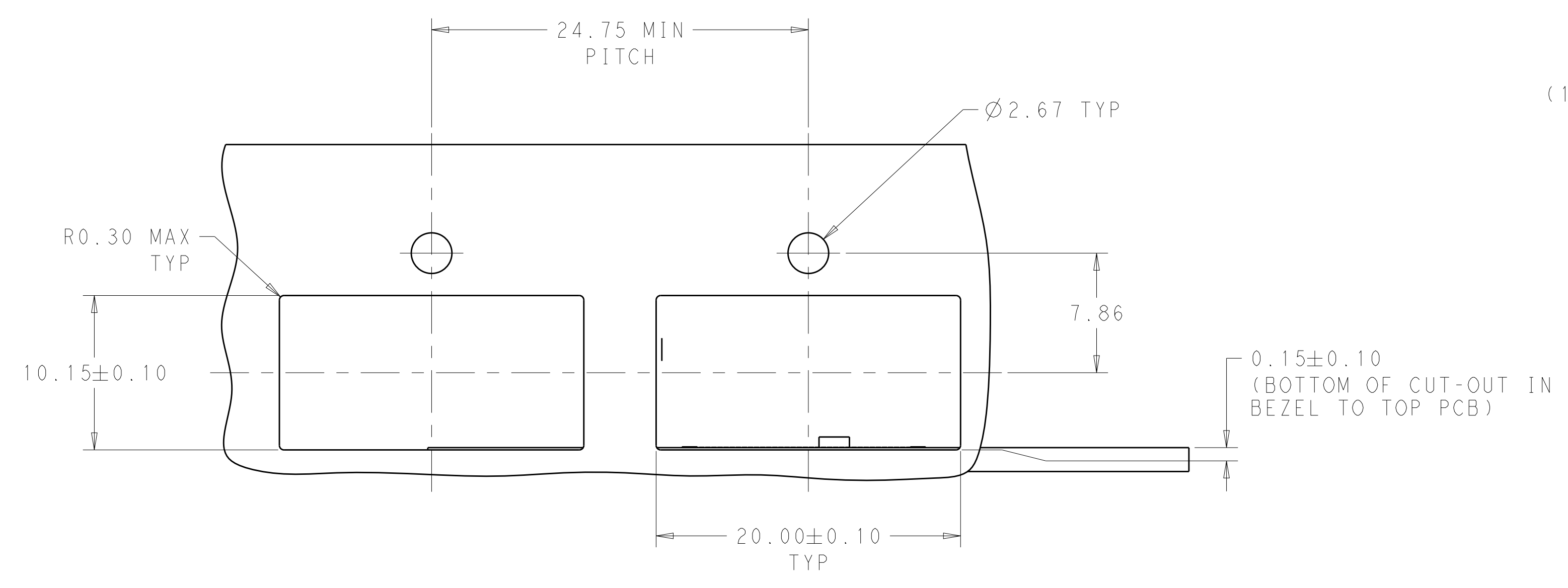

SINGLE LIGHT PIPE TYPE

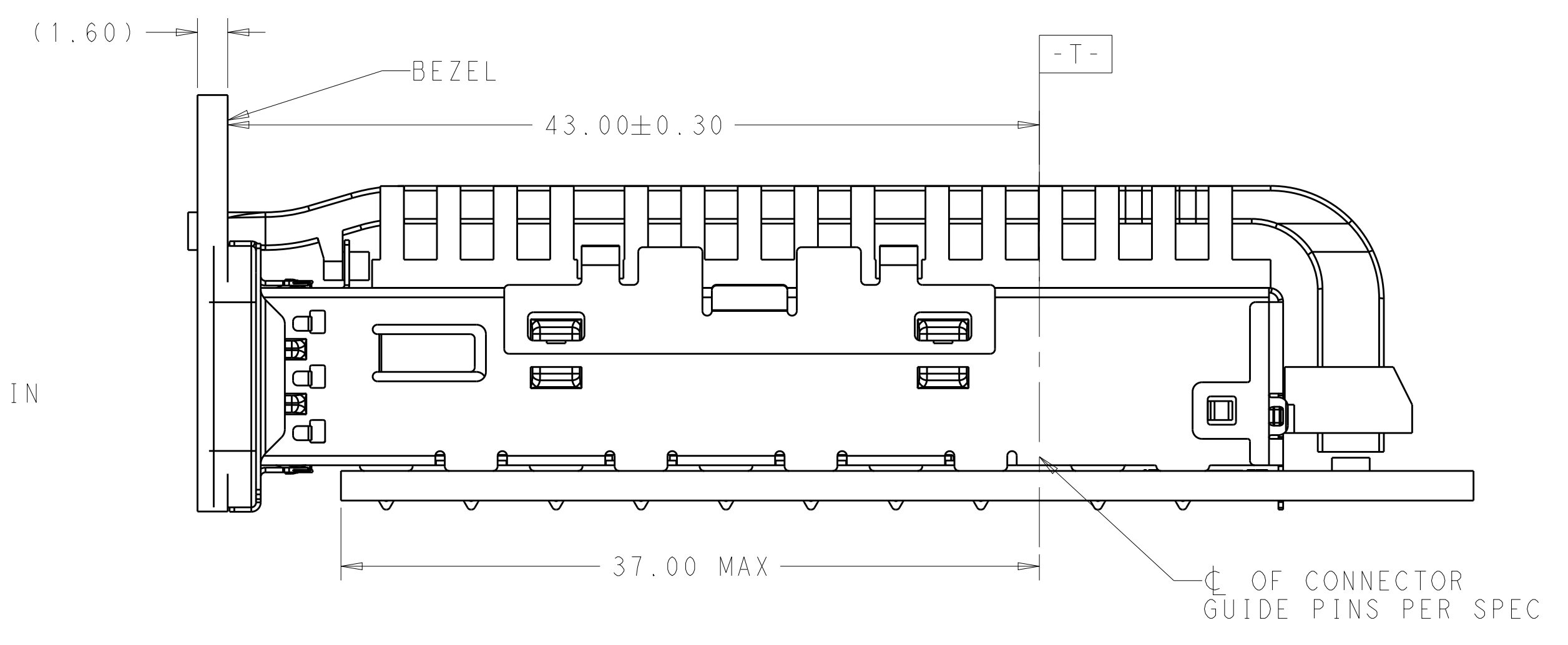

SINGLE SIDE MOUNTING SCALE 4:1

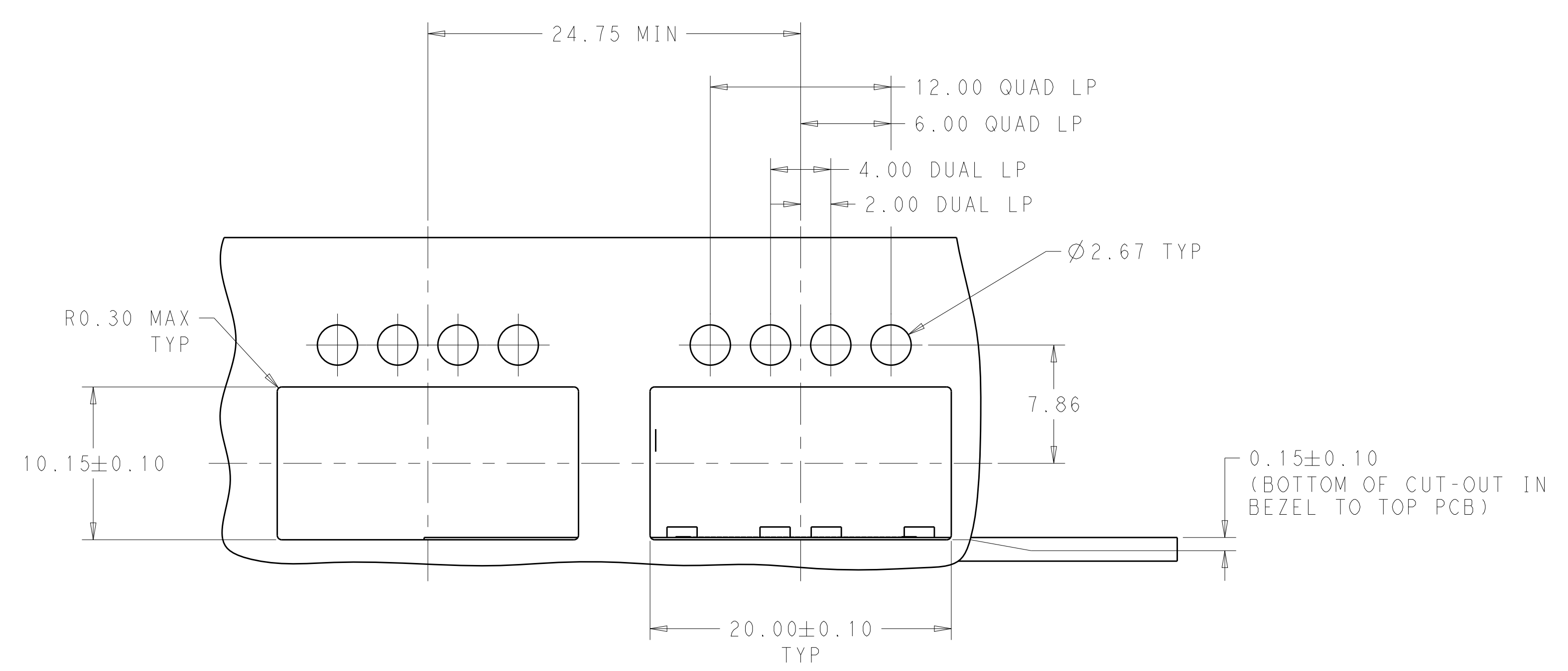

DUAL/QUAD LIGHT PIPE TYPE

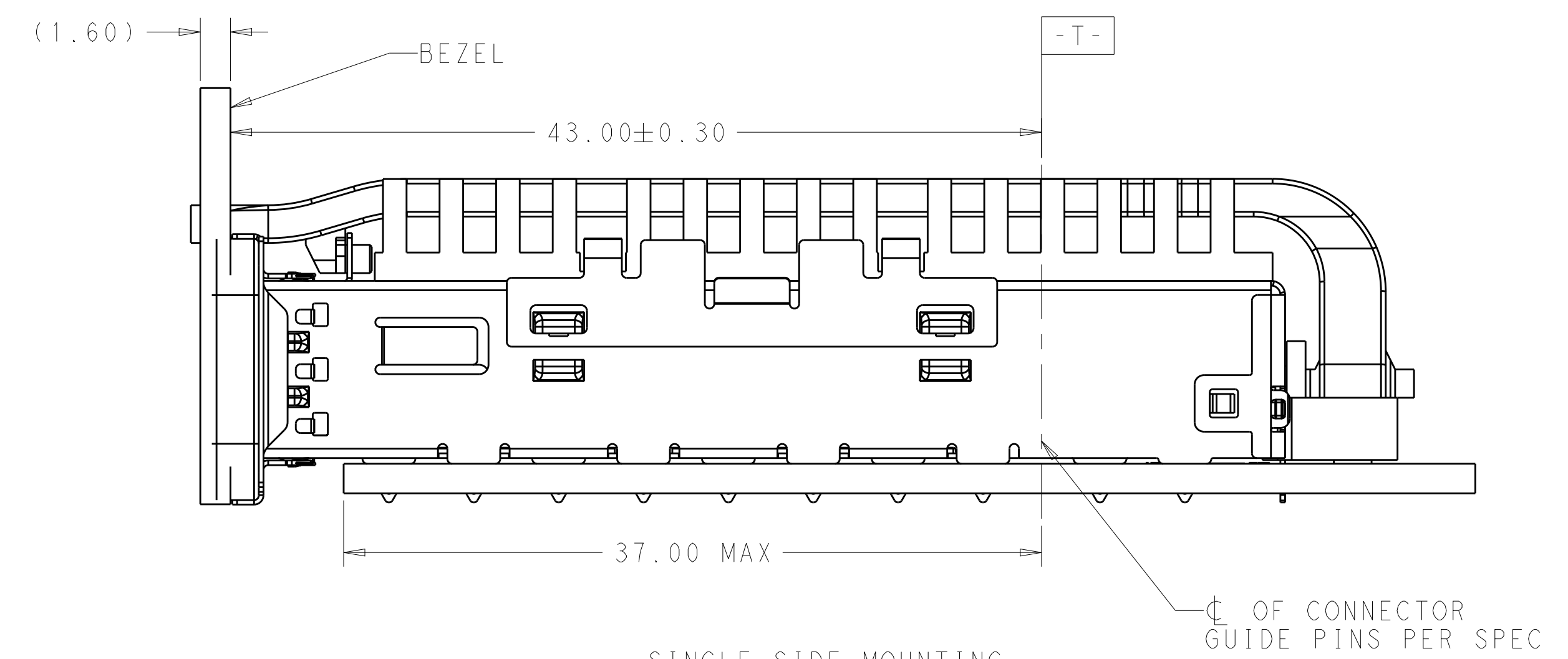

SINGLE SIDE MOUNTING SCALE 4:1

THIS DRAWING IS A CONTROLLED DOCUMENT.		DWN: JASON YANG 01APR2014	TE Connectivity
DIMENSIONS: mm		CHK: SEAN HAN 30DEC2015	
TOLERANCES UNLESS OTHERWISE SPECIFIED:		APVD: -	NAME: CAGE ASSEMBLY, QSFP28 1X1, THRU BEZEL, WITH EMI GASKET HEAT SINK, LIGHT PIPE
0 PLC	±0.25	PRODUCT SPEC	SIZE: CAGE CODE DRAWING NO
1 PLC	±0.25	108-19428	RESTRICTED TO
2 PLC	±0.20	APPLICATION SPEC	A100779C=2170754
3 PLC	±0.100	114-32023	SCALE: 4:1 SHEET 4 OF 7 REV B
4 PLC	±	Customer Drawing	
ANGLES	±		
MATERIAL			
FINISH			

LOC	DIST	REV	DATE	APPD
		1		

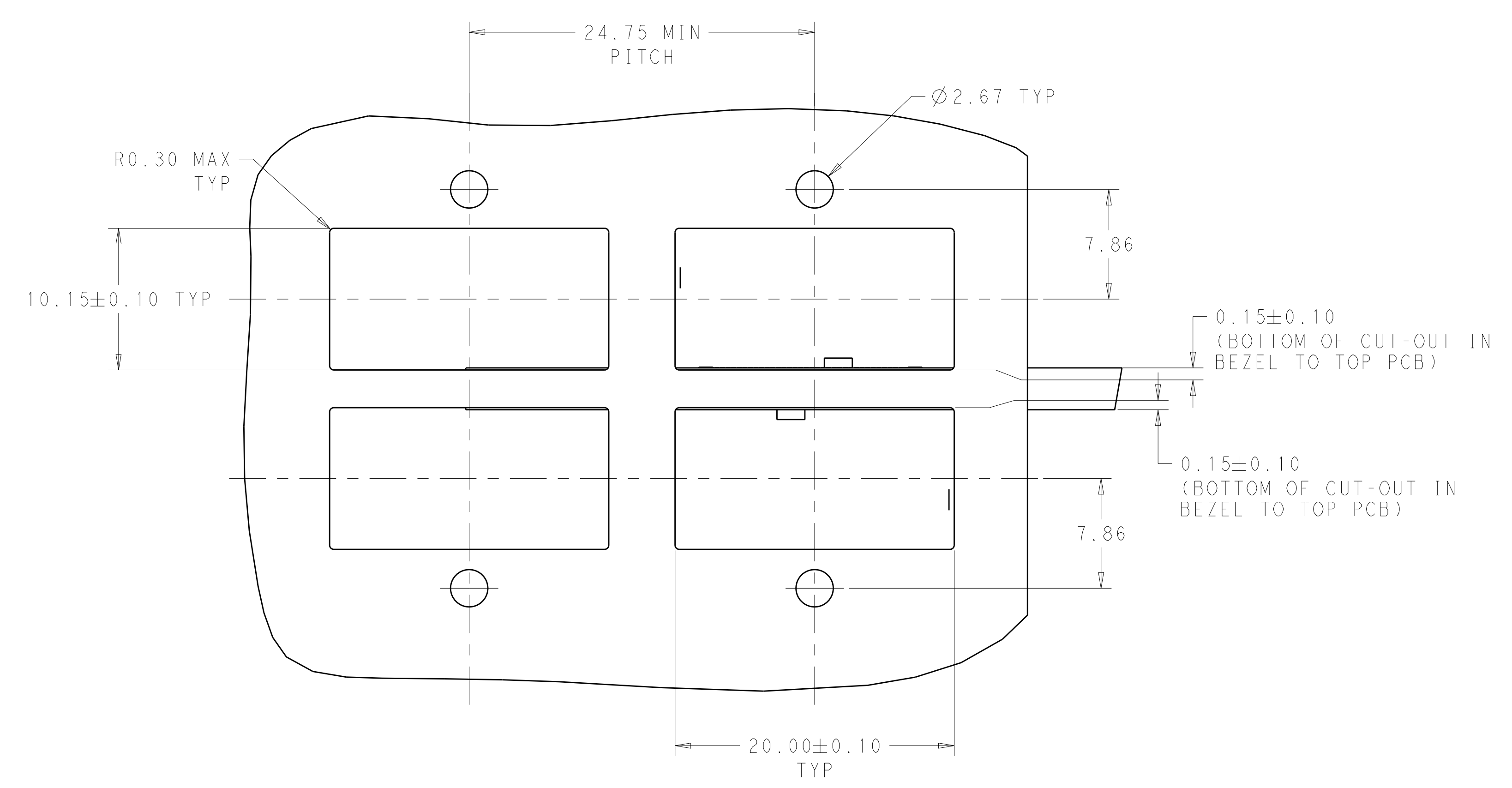

SINGLE LIGHT PIPE TYPE

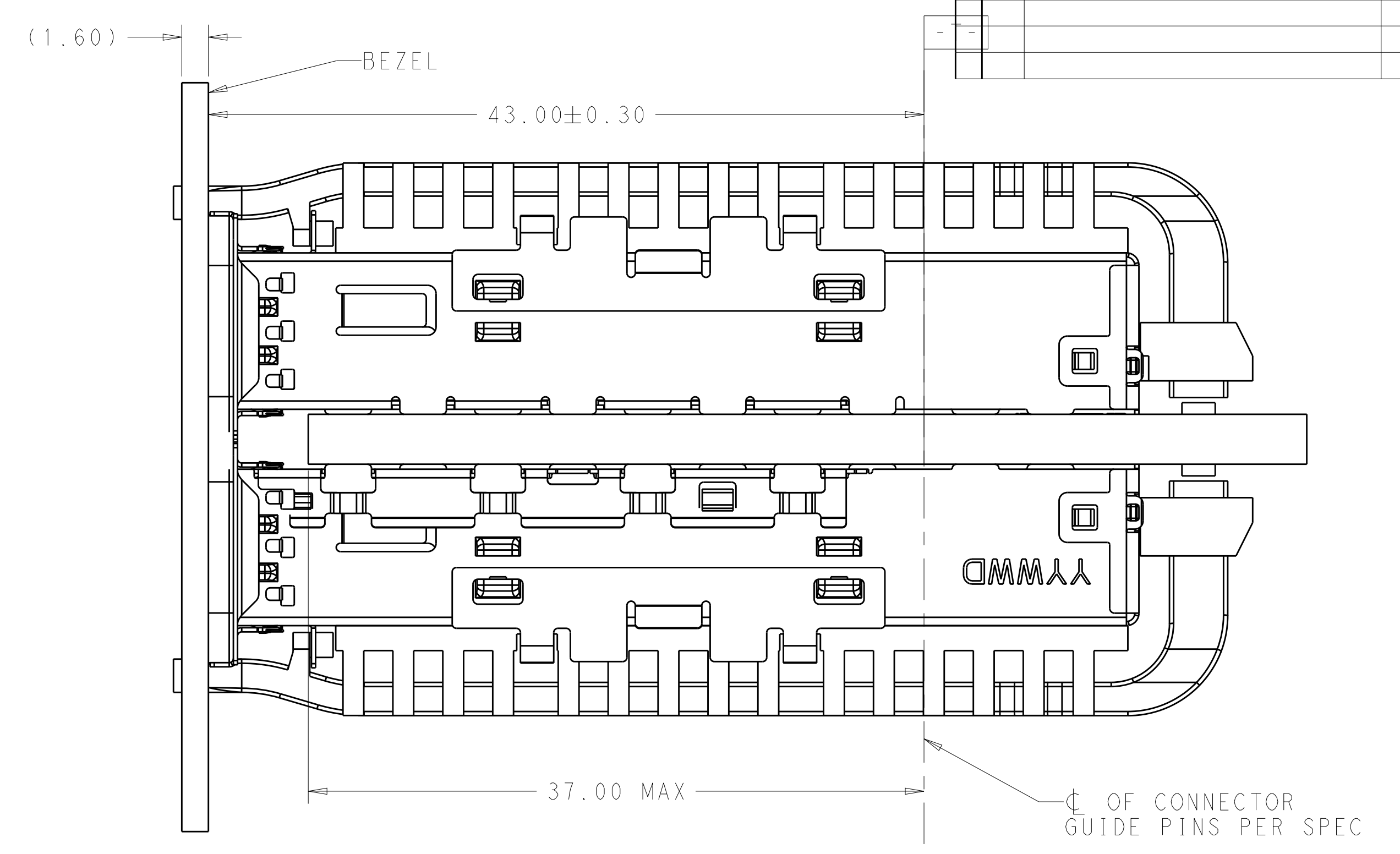

BELLY TO BELLY MOUNTING  
SCALE 4:1

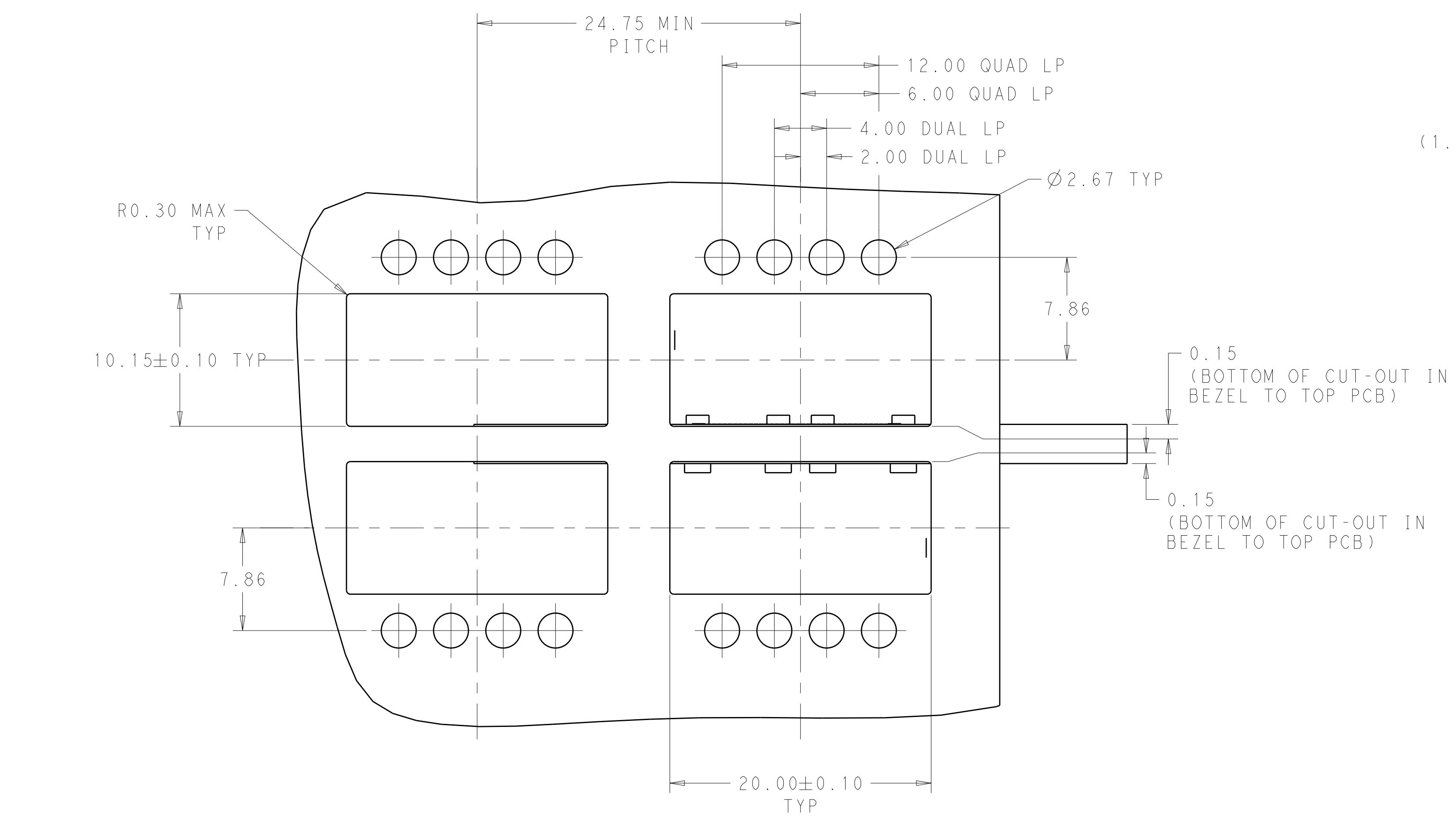

DUAL/QUAD LIGHT PIPE TYPE

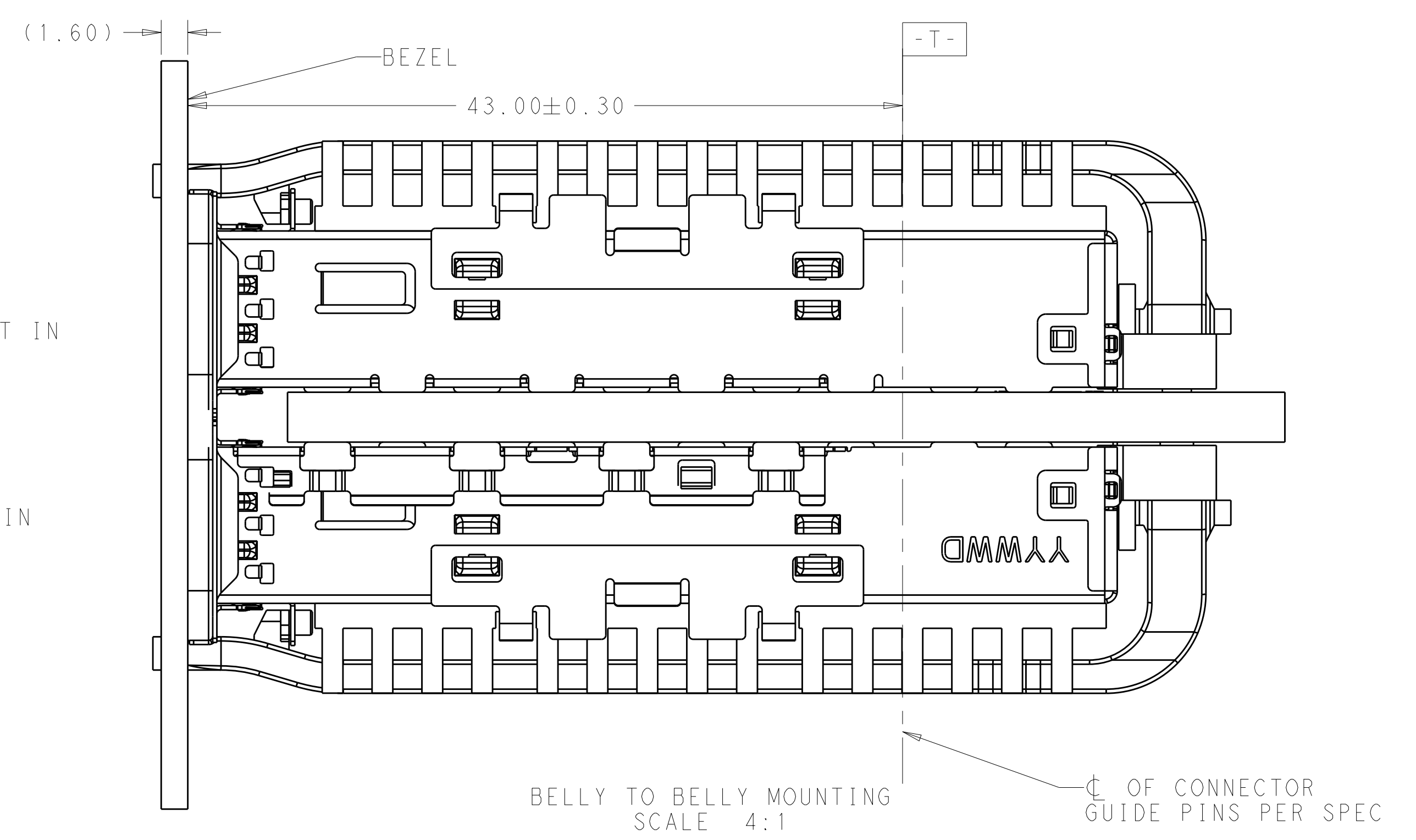

BELLY TO BELLY MOUNTING  
SCALE 4:1

THIS DRAWING IS A CONTROLLED DOCUMENT.		OWN: JASON YANG 01APR2014	TE Connectivity
DIMENSIONS: mm		CHK: SEAN HAN 30DEC2015	
TOLERANCES UNLESS OTHERWISE SPECIFIED:		APVD:	NAME: CAGE ASSEMBLY, QSP28 1X1, THRU BEZEL, WITH EMI GASKET HEAT SINK, LIGHT PIPE
0 PLC	±0.25	PRODUCT SPEC	108-19428
1 PLC	±0.25	APPLICATION SPEC	114-32023
2 PLC	±0.20	SIZE	A100779
3 PLC	±0.20	CAGE CODE	C=2170754
4 PLC	±0.100	DRAWING NO	SCALE 4:1
ANGLES	±°	WEIGHT	SHEET 5 OF 7
MATERIAL	FINISH	Customer Drawing	REV B

LOC	DIST	REV	DATE	BY	APPV
		1			

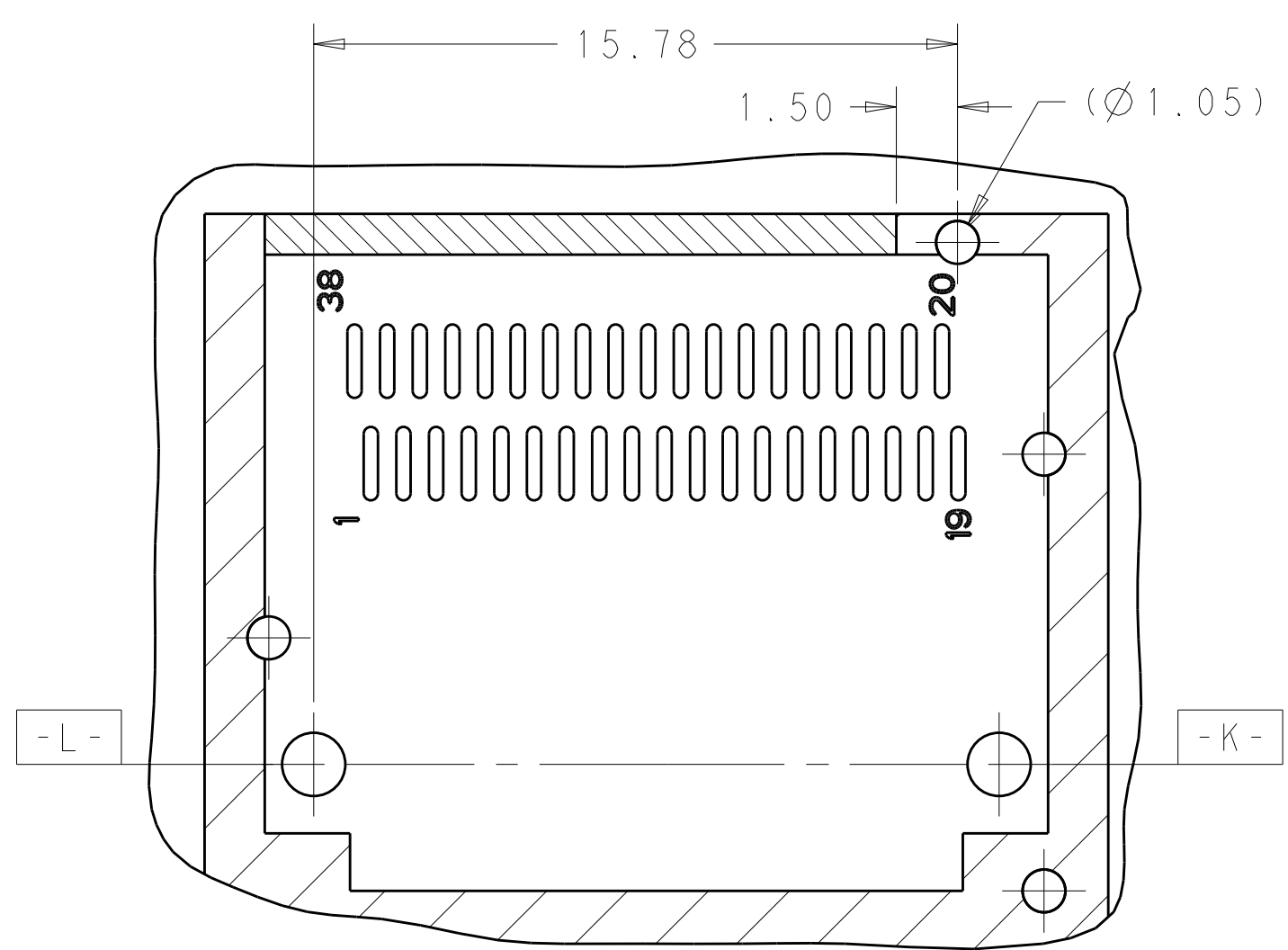
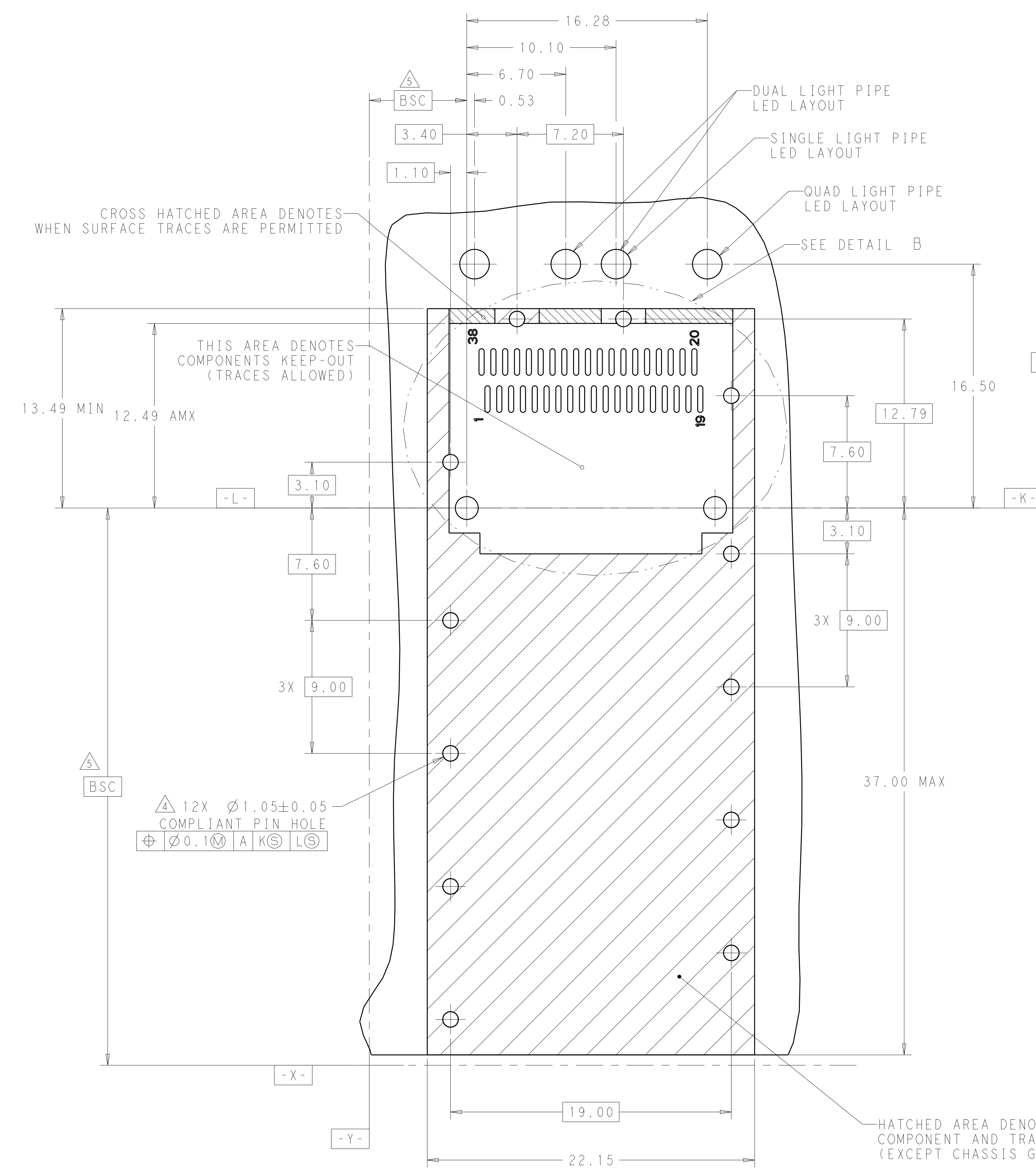

RECOMMENDED PCB LAYOUT  
 SINGLE TYPE OF 1 REAR HOLES OF LEGS  
 PCB TOLERANCE: ±0.05  
 SCALE 6:1

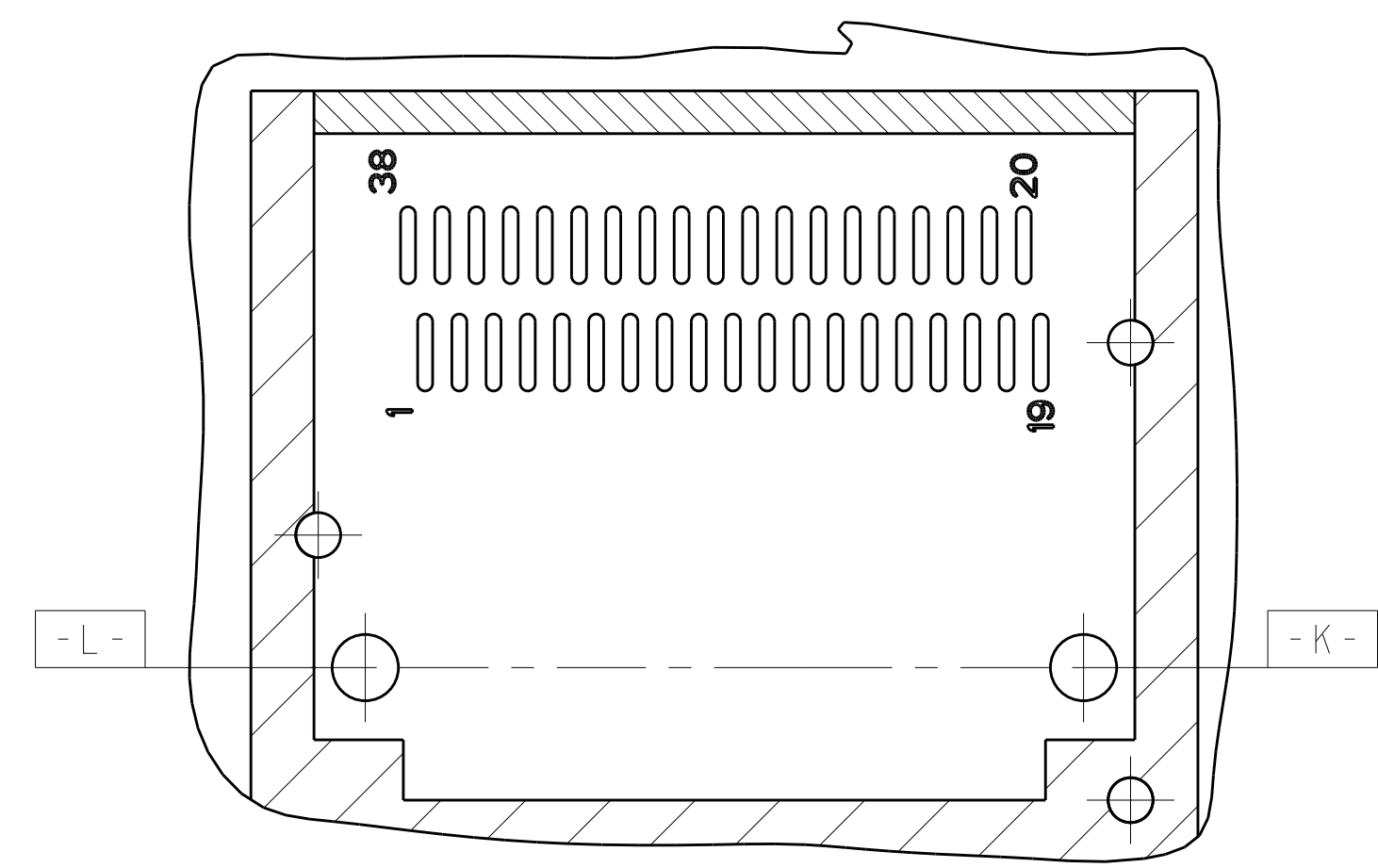

RECOMMENDED PCB LAYOUT  
 SINGLE TYPE OF 0 REAR HOLES OF LEGS  
 PCB TOLERANCE: ±0.05  
 SCALE 6:1

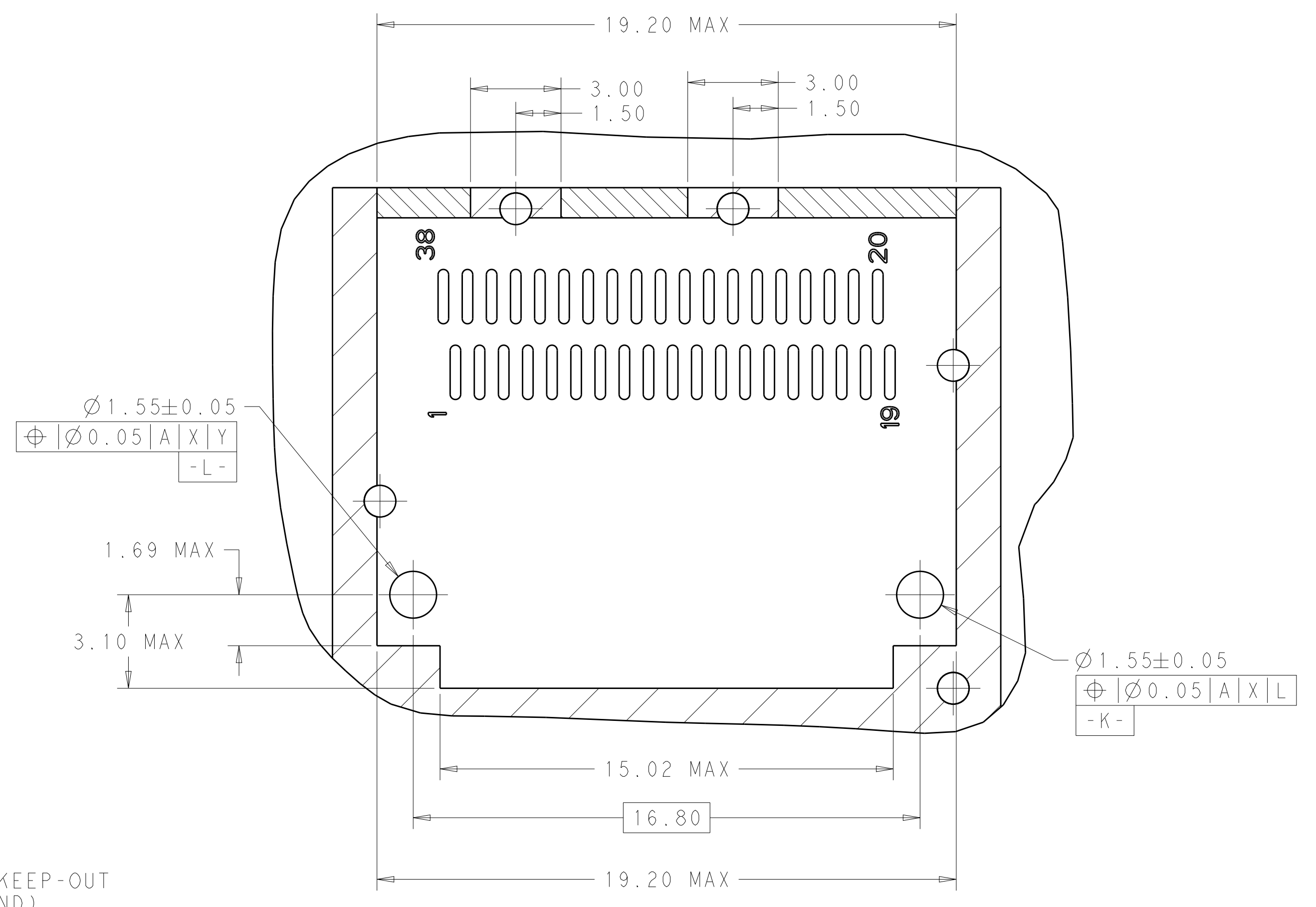

DETAIL B  
 SCALE 8:1

RECOMMENDED PCB LAYOUT  
 SINGLE TYPE OF 2 REAR HOLES OF LEGS  
 PCB TOLERANCE: ±0.05  
 SCALE 6:1

HATCHED AREA DENOTES  
 COMPONENT AND TRACE KEEP-OUT  
 (EXCEPT CHASSIS GROUND)

THIS DRAWING IS A CONTROLLED DOCUMENT.		OWN: JASON YANG 01APR2014	TE Connectivity
DIMENSIONS: mm		CHK: SEAN HAN 30DEC2015	
TOLERANCES UNLESS OTHERWISE SPECIFIED:		APVD:	NAME: CAGE ASSEMBLY, QSFP28 1X1, THRU BEZEL, WITH EMI GASKET HEAT SINK, LIGHT PIPE
0 PLC	±0.25	PRODUCT SPEC:	108-19428
1 PLC	±0.25	APPLICATION SPEC:	114-32023
2 PLC	±0.20	WEIGHT:	A100779C=2170754
3 PLC	±0.100	RESTRICTED TO:	
4 PLC	±	SCALE: 4:1	SHEET 6 OF 7
ANGLES	±	REV: B	
MATERIAL:		Customer Drawing	



LOC	DIST	REV	DATE	BY	APPD
		1			

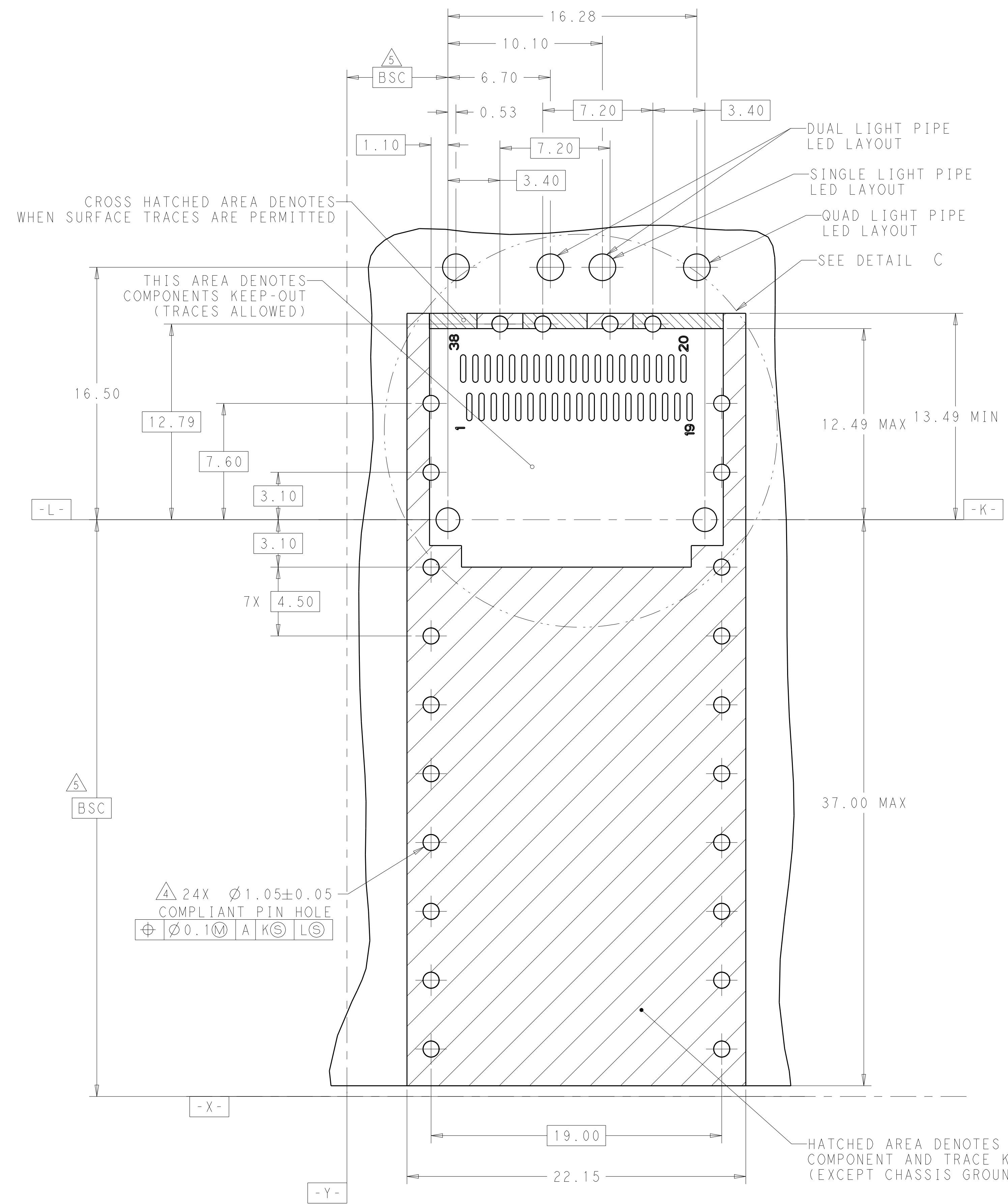

RECOMMENDED PCB LAYOUT  
 BELLY TO BELLY TYPE OF 2 REAR HOLES OF LEGS  
 PCB TOLERANCE: ±0.05  
 SCALE 6:1

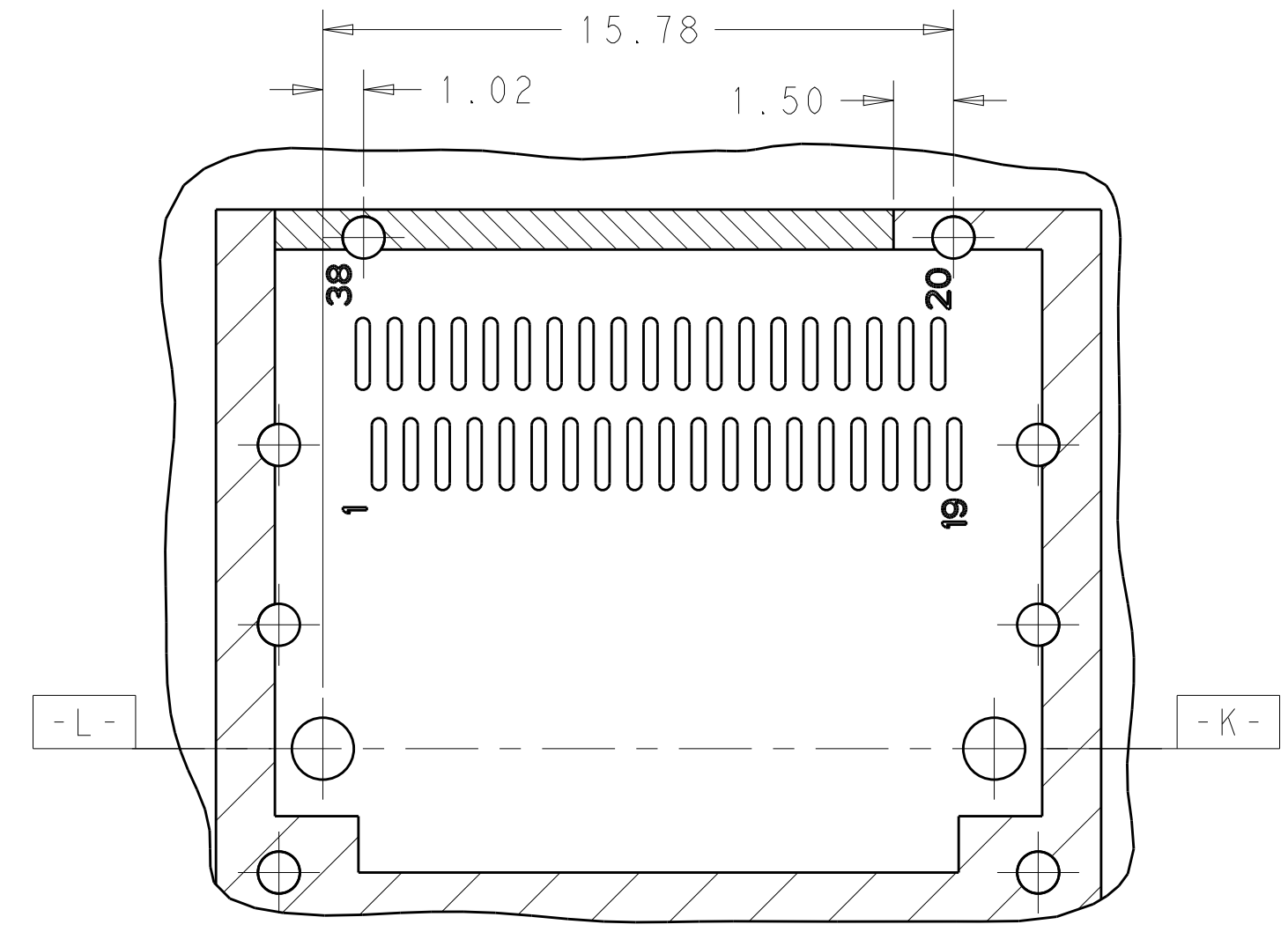

RECOMMENDED PCB LAYOUT  
 BELLY TO BELLY TYPE OF 1 REAR HOLES OF LEGS  
 PCB TOLERANCE: ±0.05  
 SCALE 6:1

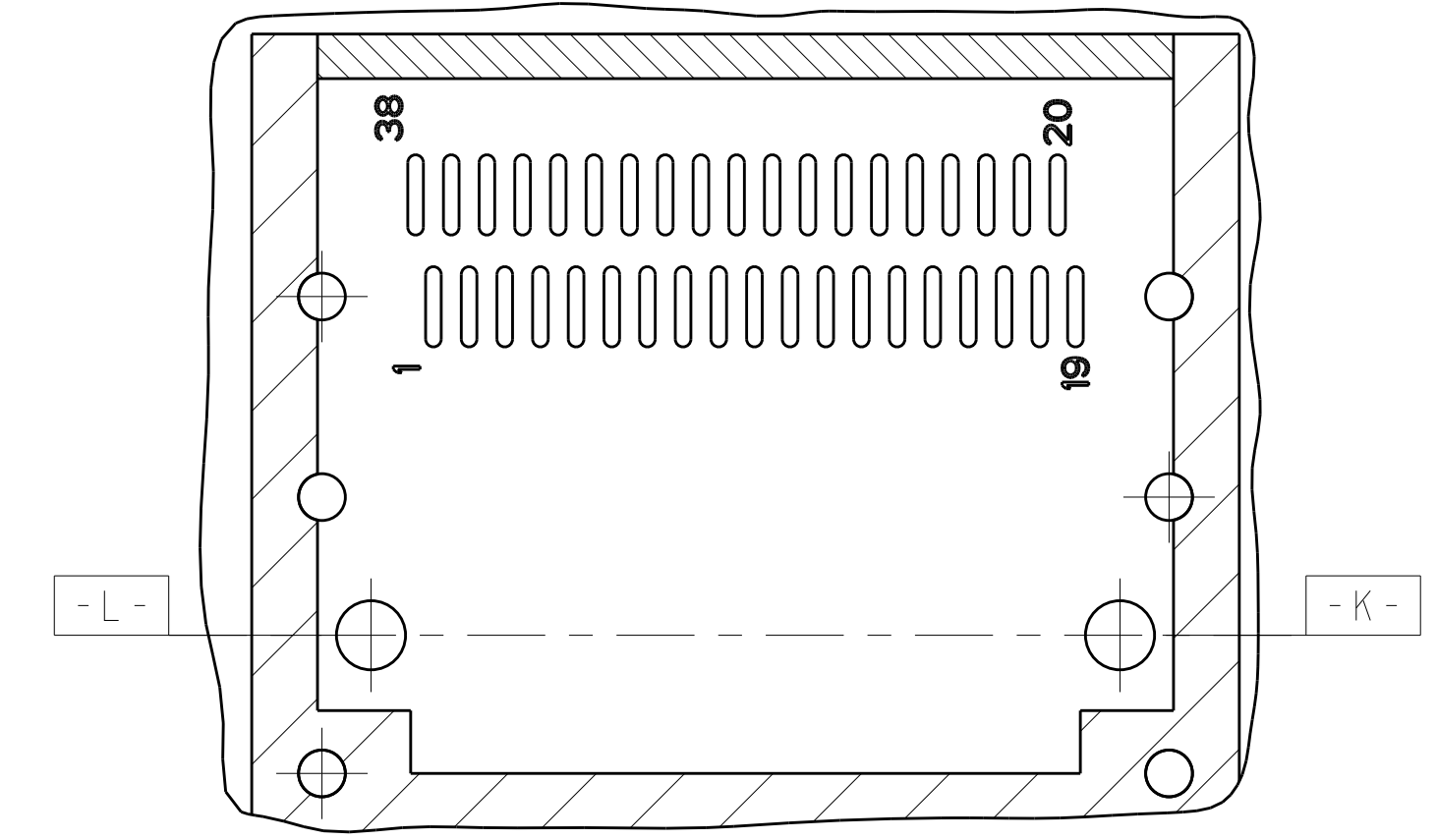

RECOMMENDED PCB LAYOUT  
 BELLY TO BELLY TYPE OF 0 REAR HOLES OF LEGS  
 PCB TOLERANCE: ±0.05  
 SCALE 6:1

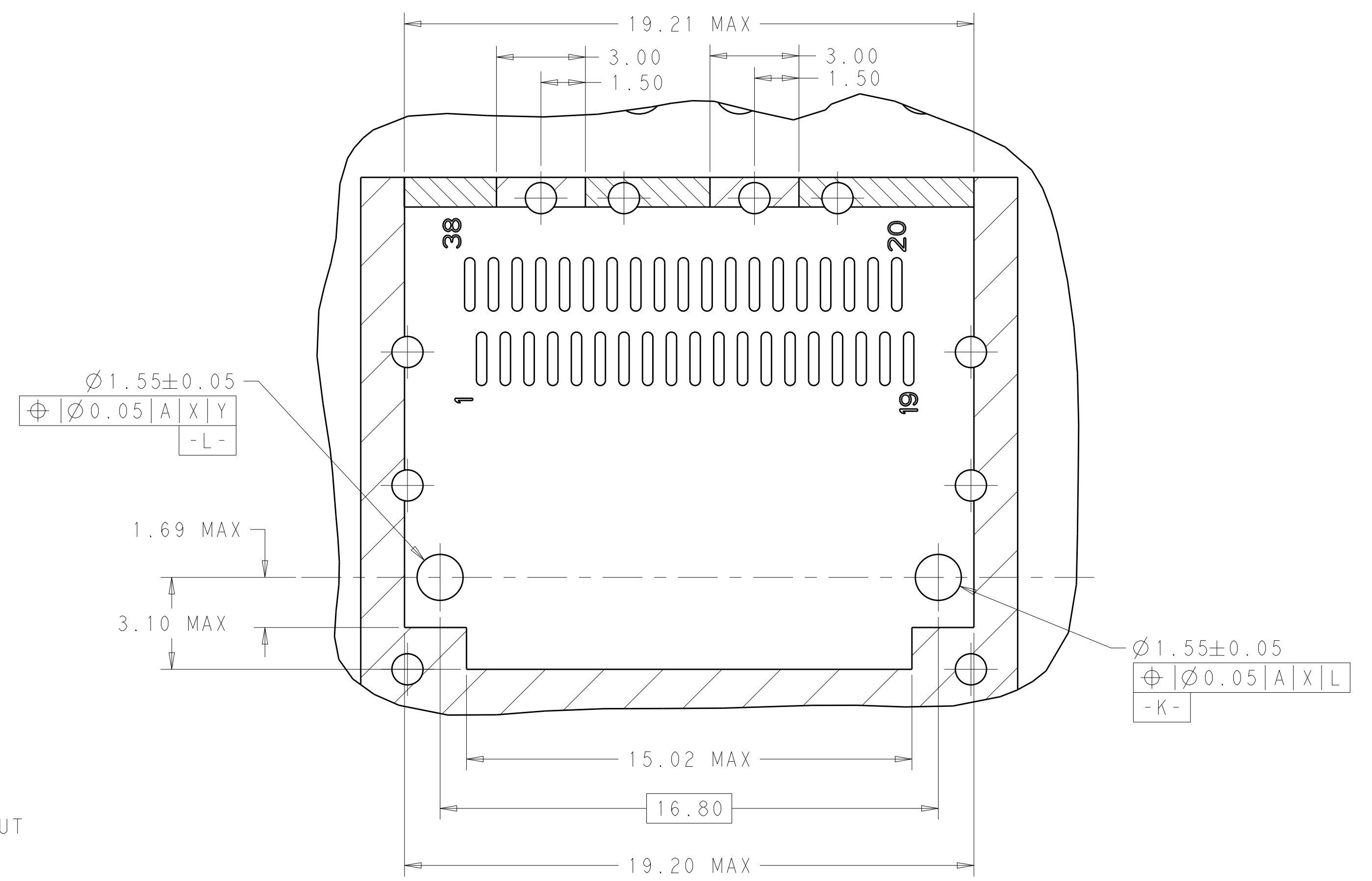

DETAIL C  
 SCALE 8:1

THIS DRAWING IS A CONTROLLED DOCUMENT.		DWN: JASON YANG 01APR2014 CHG: SEAN HAN 30DEC2015 APVD:	TE Connectivity
DIMENSIONS: mm 	TOLERANCES UNLESS OTHERWISE SPECIFIED: 0 PLC ±0.25 1 PLC ±0.25 2 PLC ±0.25 3 PLC ±0.25 4 PLC ±0.100 ANGLES ±°	NAME: CAGE ASSEMBLY, QSFP28 1X1, THRU BEZEL, WITH EMI GASKET HEAT SINK, LIGHT PIPE PRODUCT SPEC: 108-19428 APPLICATION SPEC: 114-32023 WEIGHT:	
MATERIAL:	FINISH:	Customer Drawing	SCALE: 4:1 SHEET: 7 of 7 REV: B

## X-ON Electronics

Largest Supplier of Electrical and Electronic Components

*Click to view similar products for [I/O Connectors](#) category:*

*Click to view products by [TE Connectivity](#) manufacturer:*

Other Similar products are found below :

[571763P](#) [72.250.1628.2](#) [72.250.2428.2](#) [74720-0505](#) [76.350.0729.0](#) [76871-1403](#) [FCN-244F080-G/1](#) [FCN-260A9920](#) [MP-5T180MUNNA-005](#)  
[PCR-E36PM](#) [PCS-XE26MA+](#) [G38A71314B](#) [1571250010](#) [157-22500-3](#) [MS3471L14-19P L/C](#) [91-569786-35H](#) [172501-4002](#) [172501-6002](#)  
[FCN-260C008-A/L0](#) [FCN-260C024-AL0](#) [FCN-261Z008](#) [2000314-1](#) [200331-1](#) [PCR-E36FC+](#) [PCS-E28FS+](#) [PCS-XE26SLFD+](#) [PCS-](#)  
[XE26SLFDT+](#) [G730VID08BDC24](#) [U90B2054081210](#) [UE86K842720321](#) [38113800006](#) [DP3AR020WQ1R200](#) [Z4.102.0680.0](#) [500-1040](#)  
[500-1052](#) [500-1054](#) [ZP-4008-66L](#) [0709821002](#) [10-565995-597N](#) [DX40-20P\(55\)](#) [5554841-1](#) [U90B3054061110](#) [U65-E04-4020](#)  
[ZPF00000000097891](#) [557-262M2-06C](#) [747360449](#) [10099439-003C-TRLF](#) [10137239-0021LF](#) [E9320-001-01](#) [10137239-0011LF](#)