

- THIS CONNECTOR ASSEMBLY IS SUPPLIED WITH METAL CONTACT RETENTION CLIPS INSTALLED IN THE INSERT ASSEMBLY.
- THIS CONNECTOR ASSEMBLY MEETS THE REQUIREMENTS OF LORAL SPEC 010772 AND MATES WITH ANY RECEPTACLE CONNECTOR WITH SAME INSERT ARRANGEMENT.
- MARK WITH .047 [1.19]-.062 [1.57] HIGH CHARACTERS. FAR SIDE REFERS TO THE WIDE SIDE OF THE KEYSTONE. NEAR SIDE REFERS TO THE NARROW SIDE OF THE KEYSTONE. IF THE REAR SHELL IS TOO SMALL FOR THE ENTIRE CUSTOMER PART NUMBER, MARKING SHALL BE LOCATED AS FOLLOWS:
 - "B010772" ON FRONT SHELL, FAR SIDE.
 - CUSTOMER BASE NUMBER ON FRONT SHELL, NEAR SIDE.
 - "AMP" AND DATE CODE ON FRONT SHELL, NEAR SIDE.
 - AMP PART NUMBER ON REAR SHELL, NEAR SIDE.
- DIMENSIONS ARE .155 [3.94] MINIMUM FULL PIN DIAMETER EXTENSION (SIZES 3 THRU 6) AND .164 [4.17] MINIMUM FULL PIN DIAMETER EXTENTION (SIZES 1 AND 2).
- MAXIMUM WIRE INSULATION TO BE USED WITH THIS CONNECTOR ASSEMBLY IS .072 [1.83] DIAMETER.
- FOR CONTACT CRIMPING INSTRUCTION SHEET REFER TO AMP IS 7516. FOR CONTACT INSTALLATION AND REMOVAL INSTRUCTION SHEET REFER TO AMP IS 7508.
- DIMENSIONS AND TOLERANCES PER ANSI Y14.5M-1982.
- THIS DRAWING SHALL BE INTERPRETED IN ACCORDANCE WITH APPLICABLE STANDARDS LISTED IN MIL-STD-100.

PRELIMINARY - NOT RELEASED FOR PRODUCTION	.040 [1.02] .020 [0.51]	.432 [10.97] .412 [10.46]	1.093 [27.76] 1.073 [27.25]	.241 [6.12] .229 [5.82]	.432 [10.97] .412 [10.46]	.509 [12.93] .479 [12.17]	.334 [8.48] .324 [8.23]	1.317 [33.45] 1.307 [33.20]	.999 [25.37] .989 [25.12]	1.556 [39.52] 1.526 [38.76]	MS18274-1	15	2	B010772-0044	3-448815-2	3-448815-2
PRELIMINARY - NOT RELEASED FOR PRODUCTION	.049 [1.24] .029 [0.74]	.544 [13.82] .524 [13.31]	2.188 [55.58] 2.168 [55.07]	.236 [5.99] .224 [5.69]	.436 [11.07] .416 [10.57]	.620 [15.75] .590 [14.99]	.441 [11.20] .431 [10.95]	2.411 [61.24] 2.401 [60.99]	2.084 [52.93] 2.074 [52.68]	2.650 [67.31] 2.620 [66.55]	MS18277-1	50	5	B010772-0031	1-448815-5	1-448815-5
			1.635 [41.53] 2.262 [57.45]					2.505 [63.63] 2.495 [63.37]	2.187 [55.55] 2.177 [55.30]	2.744 [69.70] 2.714 [68.94]	MS18276-1	37	4	B010772-0029	1-448815-4	1-448815-4
		.432 [10.97] .412 [10.46]	1.093 [27.76] 1.073 [27.25]	.241 [6.12] .229 [5.82]	.432 [10.97] .412 [10.46]	.509 [12.93] .479 [12.17]	.334 [8.48] .324 [8.23]	1.857 [47.17] 1.847 [46.91]	1.539 [39.09] 1.529 [38.84]	2.103 [53.42] 2.073 [52.65]	MS18275-1	25	3	B010772-0027	1-448815-3	1-448815-3
	.040 [1.02] .020 [0.51]		1.093 [27.76] 1.073 [27.25]	.241 [6.12] .229 [5.82]	.432 [10.97] .412 [10.46]			1.317 [33.45] 1.307 [33.20]	.999 [25.37] .989 [25.12]	1.556 [39.52] 1.526 [38.76]	MS18274-1	15	2	B010772-0025	1-448815-2	1-448815-2
		.544 [13.82] .524 [13.31]	2.188 [55.58] 2.168 [55.07]	.236 [5.99] .224 [5.69]	.436 [11.07] .416 [10.57]	.620 [15.75] .590 [14.99]	.441 [11.20] .431 [10.95]	2.411 [61.24] 2.401 [60.99]	2.084 [52.93] 2.074 [52.68]	2.650 [67.31] 2.620 [66.55]	MS18277-1	50	5	A010772-0009	1-448815-0	1-448815-0
	.049 [1.24] .029 [0.74]		2.282 [57.96] 2.262 [57.45]	.236 [5.99] .224 [5.69]	.436 [11.07] .416 [10.57]			2.505 [63.63] 2.495 [63.37]	2.187 [55.55] 2.177 [55.30]	2.744 [69.70] 2.714 [68.94]	MS18276-1	37	4	A010772-0007	448815-9	448815-9
		.432 [10.97] .412 [10.46]	1.635 [41.53] 2.262 [57.45]			.509 [12.93] .479 [12.17]	.334 [8.48] .324 [8.23]	1.857 [47.17] 1.847 [46.91]	1.539 [39.09] 1.529 [38.84]	2.103 [53.42] 2.073 [52.65]	MS18275-1	25	3	A010772-0005	448815-8	448815-8
	.040 [1.02] .020 [0.51]		1.093 [27.76] 1.073 [27.25]	.241 [6.12] .229 [5.82]	.432 [10.97] .412 [10.46]			1.317 [33.45] 1.307 [33.20]	.999 [25.37] .989 [25.12]	1.556 [39.52] 1.526 [38.76]	MS18274-1	15	2	A010772-0003	448815-7	448815-7
		.544 [13.82] .524 [13.31]	2.188 [55.58] 2.168 [55.07]	.236 [5.99] .224 [5.69]	.436 [11.07] .416 [10.57]	.620 [15.75] .590 [14.99]	.441 [11.20] .431 [10.95]	2.411 [61.24] 2.401 [60.99]	2.084 [52.93] 2.074 [52.68]	2.650 [67.31] 2.620 [66.55]	MS18277-1	50	5	B010772-0009	448815-5	448815-5
	.049 [1.24] .029 [0.74]		2.282 [57.96] 2.262 [57.45]	.236 [5.99] .224 [5.69]	.436 [11.07] .416 [10.57]			2.505 [63.63] 2.495 [63.37]	2.187 [55.55] 2.177 [55.30]	2.744 [69.70] 2.714 [68.94]	MS18276-1	37	4	B010772-0007	448815-4	448815-4
		.432 [10.97] .412 [10.46]	1.635 [41.53] 2.262 [57.45]			.509 [12.93] .479 [12.17]	.334 [8.48] .324 [8.23]	1.857 [47.17] 1.847 [46.91]	1.539 [39.09] 1.529 [38.84]	2.103 [53.42] 2.073 [52.65]	MS18275-1	25	3	B010772-0005	448815-3	448815-3
	.040 [1.02] .020 [0.51]		1.093 [27.76] 1.073 [27.25]	.241 [6.12] .229 [5.82]	.432 [10.97] .412 [10.46]			1.317 [33.45] 1.307 [33.20]	.999 [25.37] .989 [25.12]	1.556 [39.52] 1.526 [38.76]	MS18274-1	15	2	B010772-0003	448815-2	448815-2
		.544 [13.82] .524 [13.31]	2.188 [55.58] 2.168 [55.07]	.236 [5.99] .224 [5.69]	.436 [11.07] .416 [10.57]	.620 [15.75] .590 [14.99]	.441 [11.20] .431 [10.95]	2.411 [61.24] 2.401 [60.99]	2.084 [52.93] 2.074 [52.68]	2.650 [67.31] 2.620 [66.55]	MS18277-1	50	5	B010772-0009	448815-5	448815-5
	.049 [1.24] .029 [0.74]		2.282 [57.96] 2.262 [57.45]	.236 [5.99] .224 [5.69]	.436 [11.07] .416 [10.57]			2.505 [63.63] 2.495 [63.37]	2.187 [55.55] 2.177 [55.30]	2.744 [69.70] 2.714 [68.94]	MS18276-1	37	4	B010772-0007	448815-4	448815-4
		.432 [10.97] .412 [10.46]	1.635 [41.53] 2.262 [57.45]			.509 [12.93] .479 [12.17]	.334 [8.48] .324 [8.23]	1.857 [47.17] 1.847 [46.91]	1.539 [39.09] 1.529 [38.84]	2.103 [53.42] 2.073 [52.65]	MS18275-1	25	3	B010772-0005	448815-3	448815-3
	.040 [1.02] .020 [0.51]		1.093 [27.76] 1.073 [27.25]	.241 [6.12] .229 [5.82]	.432 [10.97] .412 [10.46]			1.317 [33.45] 1.307 [33.20]	.999 [25.37] .989 [25.12]	1.556 [39.52] 1.526 [38.76]	MS18274-1	15	2	B010772-0003	448815-2	448815-2
		.544 [13.82] .524 [13.31]	2.188 [55.58] 2.168 [55.07]	.236 [5.99] .224 [5.69]	.436 [11.07] .416 [10.57]	.620 [15.75] .590 [14.99]	.441 [11.20] .431 [10.95]	2.411 [61.24] 2.401 [60.99]	2.084 [52.93] 2.074 [52.68]	2.650 [67.31] 2.620 [66.55]	MS18277-1	50	5	B010772-0009	448815-5	448815-5
	.049 [1.24] .029 [0.74]		2.282 [57.96] 2.262 [57.45]	.236 [5.99] .224 [5.69]	.436 [11.07] .416 [10.57]			2.505 [63.63] 2.495 [63.37]	2.187 [55.55] 2.177 [55.30]	2.744 [69.70] 2.714 [68.94]	MS18276-1	37	4	B010772-0007	448815-4	448815-4
		.432 [10.97] .412 [10.46]	1.635 [41.53] 2.262 [57.45]			.509 [12.93] .479 [12.17]	.334 [8.48] .324 [8.23]	1.857 [47.17] 1.847 [46.91]	1.539 [39.09] 1.529 [38.84]	2.103 [53.42] 2.073 [52.65]	MS18275-1	25	3	B010772-0005	448815-3	448815-3
	.040 [1.02] .020 [0.51]		1.093 [27.76] 1.073 [27.25]	.241 [6.12] .229 [5.82]	.432 [10.97] .412 [10.46]			1.317 [33.45] 1.307 [33.20]	.999 [25.37] .989 [25.12]	1.556 [39.52] 1.526 [38.76]	MS18274-1	15	2	B010772-0003	448815-2	448815-2
		.544 [13.82] .524 [13.31]	2.188 [55.58] 2.168 [55.07]	.236 [5.99] .224 [5.69]	.436 [11.07] .416 [10.57]	.620 [15.75] .590 [14.99]	.441 [11.20] .431 [10.95]	2.411 [61.24] 2.401 [60.99]	2.084 [52.93] 2.074 [52.68]	2.650 [67.31] 2.620 [66.55]	MS18277-1	50	5	B010772-0009	448815-5	448815-5
	.049 [1.24] .029 [0.74]		2.282 [57.96] 2.262 [57.45]	.236 [5.99] .224 [5.69]	.436 [11.07] .416 [10.57]			2.505 [63.63] 2.495 [63.37]	2.187 [55.55] 2.177 [55.30]	2.744 [69.70] 2.714 [68.94]	MS18276-1	37	4	B010772-0007	448815-4	448815-4
		.432 [10.97] .412 [10.46]	1.635 [41.53] 2.262 [57.45]			.509 [12.93] .479 [12.17]	.334 [8.48] .324 [8.23]	1.857 [47.17] 1.847 [46.91]	1.539 [39.09] 1.529 [38.84]	2.103 [53.42] 2.073 [52.65]	MS18275-1	25	3	B010772-0005	448815-3	448815-3
	.040 [1.02] .020 [0.51]		1.093 [27.76] 1.073 [27.25]	.241 [6.12] .229 [5.82]	.432 [10.97] .412 [10.46]			1.317 [33.45] 1.307 [33.20]	.999 [25.37] .989 [25.12]	1.556 [39.52] 1.526 [38.76]	MS18274-1	15	2	B010772-0003	448815-2	448815-2
		.544 [13.82] .524 [13.31]	2.188 [55.58] 2.168 [55.07]	.236 [5.99] .224 [5.69]	.436 [11.07] .416 [10.57]	.620 [15.75] .590 [14.99]	.441 [11.20] .431 [10.95]	2.411 [61.24] 2.401 [60.99]	2.084 [52.93] 2.074 [52.68]	2.650 [67.31] 2.620 [66.55]	MS18277-1	50	5	B010772-0009	448815-5	448815-5
	.049 [1.24] .029 [0.74]		2.282 [57.96] 2.262 [57.45]	.236 [5.99] .224 [5.69]	.436 [11.07] .416 [10.57]			2.505 [63.63] 2.495 [63.37]	2.187 [55.55] 2.177 [55.30]	2.744 [69.70] 2.714 [68.94]	MS18276-1	37	4	B010772-0007	448815-4	448815-4
		.432 [10.97] .412 [10.46]	1.635 [41.53] 2.262 [57.45]			.509 [12.93] .479 [12.17]	.334 [8.48] .324 [8.23]	1.857 [47.17] 1.847 [46.91]	1.539 [39.09] 1.529 [38.84]	2.103 [53.42] 2.073 [52.65]	MS18275-1	25	3	B010772-0005	448815-3	448815-3
	.040 [1.02] .020 [0.51]		1.093 [27.76] 1.073 [27.25]	.241 [6.12] .229 [5.82]	.432 [10.97] .412 [10.46]			1.317 [33.45] 1.307 [33.20]	.999 [25.37] .989 [25.12]	1.556 [39.52] 1.526 [38.76]	MS18274-1	15	2	B010772-0003	448815-2	448815-2
		.544 [13.82] .524 [13.31]	2.188 [55.58] 2.168 [55.07]	.236 [5.99] .224 [5.69]	.436 [11.07] .416 [10.57]	.620 [15.75] .590 [14.99]	.441 [11.20] .431 [10.95]	2.411 [61.24] 2.401 [60.99]	2.084 [52.93] 2.074 [52.68]	2.650 [67.31] 2.620 [66.55]	MS18277-1	50	5	B010772-0009	448815-5	448815-5
	.049 [1.24] .029 [0.74]		2.282 [57.96] 2.262 [57.45]	.236 [5.99] .224 [5.69]	.436 [11.07] .416 [10.57]			2.505 [63.63] 2.495 [63.37]	2.187 [55.55] 2.177 [55.30]	2.744 [69.70] 2.714 [68.94]	MS18276-1	37	4	B010772-0007	448815-4	448815-4
		.432 [10.97] .412 [10.46]	1.635 [41.53] 2.262 [57.45]			.509 [12.93] .479 [12.17]	.334 [8.48] .324 [8.23]	1.857 [47.17] 1.847 [46.91]	1.539 [39.09] 1.529 [38.84]	2.103 [53.42] 2.073 [52.65]	MS18275-1	25	3	B010772-0005	448815-3	448815-3
	.040 [1.02] .020 [0.51]		1.093 [27.76] 1.073 [27.25]	.241 [6.12] .229 [5.82]	.432 [10.97] .412 [10.46]			1.317 [33.45] 1.307 [33.20]	.999 [25.37] .989 [25.12]	1.556 [39.52] 1.526 [38.76]	MS18274-1	15	2	B010772-0003	448815-2	448815-2
		.544 [13.82] .524 [13.31]	2.188 [55.58] 2.168 [55.07]	.236 [5.99] .224 [5.69]	.436 [11.07] .416 [10.57]	.620 [15.75] .590 [14.99]	.441 [11.20] .431 [10.95]	2.411 [61.24] 2.401 [60.99]	2.084 [52.93] 2.074 [52.68]	2.650 [67.31] 2.620 [66.55]	MS18277-1	50	5	B010772-0009	448815-5	448815-5
	.049 [1.24] .029 [0.74]		2.282 [57.96] 2.262 [57.45]	.236 [5.99] .224 [5.69]	.436 [11.07] .416 [10.57]			2.505 [63.63] 2.495 [63.37]	2.187 [55.55] 2.177 [55.30]	2.744 [69.70] 2.714 [68.94]	MS18276-1	37	4	B010772-0007	448815-4	448815-4
		.432 [10.97] .412 [10.46]	1.635 [41.53] 2.262 [57.45]			.509 [12.93] .479 [12.17]	.334 [8.48] .324 [8.23]	1.857 [47.17] 1.847 [46.91]	1.539 [39.09] 1.529 [38.84]	2.103 [53.42] 2.073 [52.65]	MS18275-1	25	3	B010772-0005	448815-3	448815-3
	.040 [1.02] .020 [0.51]		1.093 [27.76] 1.073 [27.25]	.241 [6.12] .229 [5.82]	.432 [10.97] .412 [10.46]			1.317 [33.45] 1.307 [33.20]	.999 [25.37] .989 [25.12]	1.556 [39.52] 1.526 [38.76]	MS18274-1	15	2	B0107		

LOC		DIST		REVISIONS			
P	LYR	DESCRIPTION	DATE	DNW	APVD		
-	-	SEE SHEET 1	-	-	-	-	-

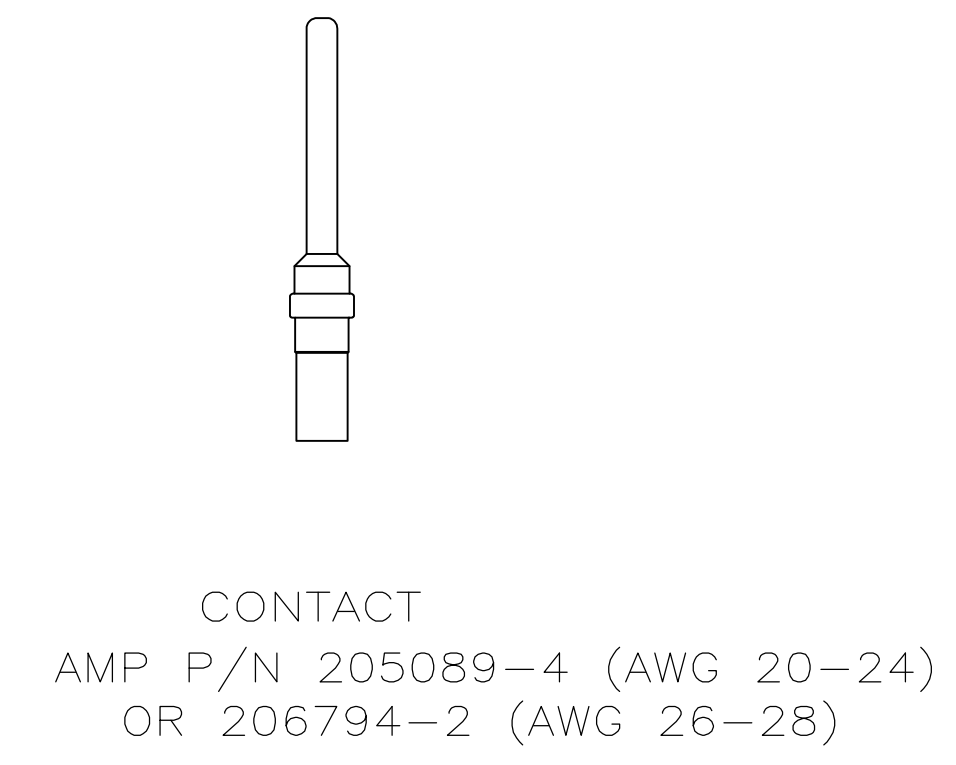
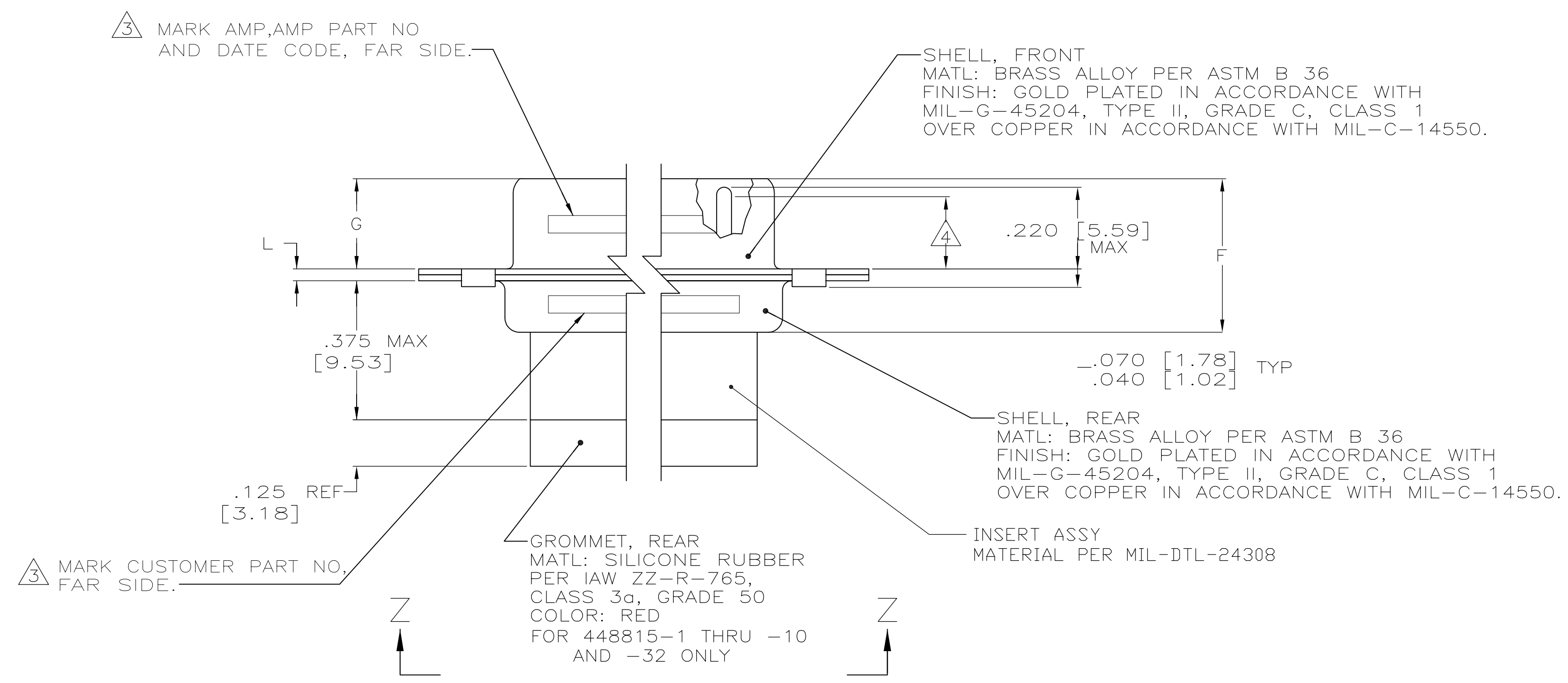
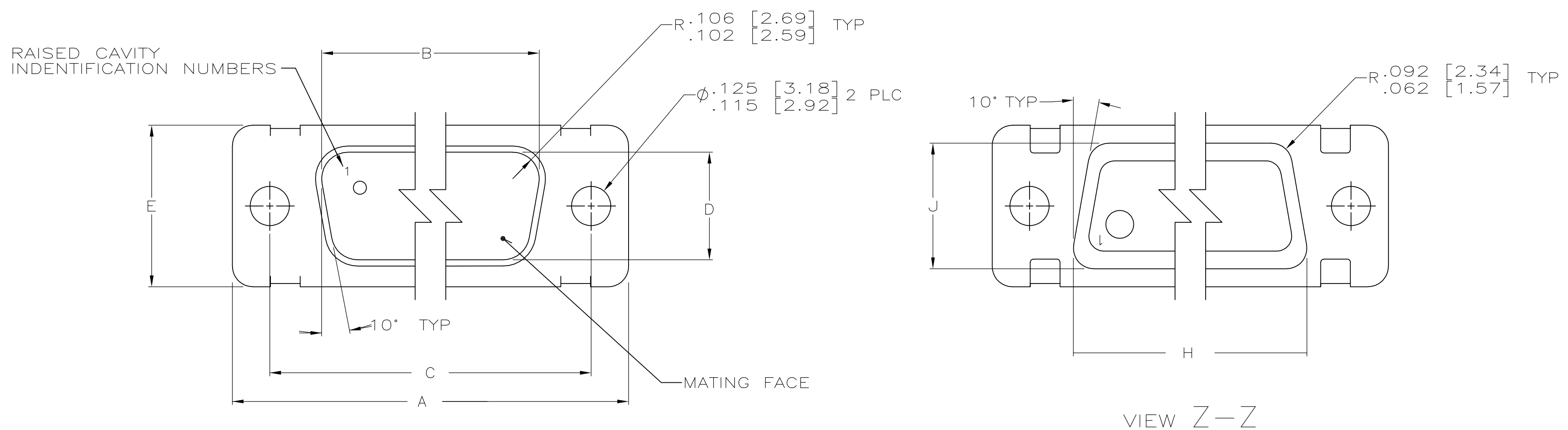

THIS DRAWING IS A CONTROLLED DOCUMENT.		DWN AJ GRAFF 2-11-93 CHK F. KINSEY 2-17-93 APVD -	TE Connectivity
DIMENSIONS: INCHES 	TOLERANCES UNLESS OTHERWISE SPECIFIED: 0 PLC ± - 1 PLC ± - 2 PLC ± - 3 PLC ± - 4 PLC ± - ANGLES ± -	PRODUCT SPEC MIL-C-24308 APPLICATION SPEC -	NAME AMPLIMITE NONMAGNETIC PLUG ASSY WITH SIZE 20 CRIMP TYPE PIN CONTACTS, SERIES 109, SIZE A1 CAGE CODE 00779 DRAWING NO 448815 RESTRICTED TO -
MATERIAL SEE CALLOUTS	FINISH SEE CALLOUTS	WEIGHT -	CUSTOMER DRAWING SCALE 4:1 SHEET 2 OF 2 REV E

X-ON Electronics

Largest Supplier of Electrical and Electronic Components

Click to view similar products for [D-Sub Standard Connectors](#) category:

Click to view products by [TE Connectivity](#) manufacturer:

Other Similar products are found below :

[DCM37S732N](#) [DAM15P500](#) [DEV09S364GTLF](#) [DEM09P032N](#) [DDM50P732N](#) [DAM15S332N](#) [173109-2218](#) [173109-2466](#) [173109-2436](#)
[173109-2435](#) [56F706-005-LI](#) [56F711-015](#) [015-0341-000](#) [015-0372-008](#) [015-8544-011](#) [017041-0005](#) [020419-0104](#) [012-0515-000](#) [012-9507-](#)
[034](#) [012-9507-114](#) [012-9534-001](#) [020745-0008](#) [609-25P](#) [M24308/2-23Z](#) [M243082310F](#) [M243082410F](#) [M243082411F](#) [M24308/4-21](#)
[CT1A18-11PSA206](#) [CT1N36-5SC](#) [CT2-16S-17PS](#) [CT2-20-15PCAU](#) [CT2-24-12PS](#) [CT2-24-28PSF127A206](#) [CT2-32-9PC](#) [CT6F9767-14-4-](#)
[14S-5PC](#) [CT6FA10SL-4PS](#) [CT7-18-10SC](#) [CT7-18-10SCAU](#) [CT7-18-12SCAU](#) [CT7-18-1PC](#) [CT7-18-1PCAU](#) [CT7-18-21SCAU](#) [M83513/01-](#)
[FC](#) [M83723/76W24619 L/C](#) [M85049/48-3-2F](#) [69001-865](#) [6STD09PCM99B70X](#) [6STD09SCM99B30X](#) [6STD09SCT99S40X](#)