



MS4515DO

SPECIFICATIONS

- PCB Mounted Digital Output Transducer
- Combination Temperature and Pressure
- Pressure Ranges from 2 to 30 inches H₂O
- I²C or SPI Protocol
- Differential & Gage
- Temperature Compensated
- 3.3 or 5.0 V_{DC} Supply Voltage
- Low Power Option Available (standby < 1μA)

The MS4515DO is a small, ceramic based, PCB mounted pressure transducer from TE Connectivity. The transducer is built using the latest CMOS sensor conditioning circuitry to create a low cost, high performance digital output pressure (14bit) and temperature (11bit) transducer designed to meet the strictest requirements from OEM customers.

The MS4515DO is fully calibrated and temperature compensated with a total error band (TEB) of less than 1.0% over the compensated range. The sensor operates from single supply of either 3.3 or 5.0V_{DC} and requires a single external component for proper operation.

The rugged ceramic transducer is available in side port, top port, and manifold mount and can measure gage or differential pressure from 2 to 30 inches H₂O. The 1/8" barbed pressure ports mate securely with 3/32" ID tubing.

FEATURES

- Inches H₂O Pressure Ranges
- PCB Mountable
- Digital Output
- Barbed Pressure Ports

APPLICATIONS

- Blocked Filter Detection
- Altitude and Airspeed Measurements
- Medical Instruments
- Fire Suppression System
- Panel Meter
- Air Movement/Environmental Controls
- Pneumatic Controls

STANDARD RANGES (INCHES H₂O)

Range	Gage	Differential	Option Availability
2		DS, SS, TP, MM	-L
4	DS, SS, TP, MM	DS, SS, TP, MM	-L
5	DS, SS, TP, MM	DS, SS, TP, MM	-L
10	DS, SS, TP, MM	DS, SS, TP, MM	-F, -L, -M
20	DS, SS, TP, MM	DS, SS, TP, MM	-F, -L, -M
30	DS, SS, TP, MM	DS, SS, TP, MM	-F, -L, -M

See Package Configurations: DS= Dual Side Port, SS= Single Side Port, TP= Top Port, MM= Manifold Mount
 Only I²C Protocol is Available on "L" type Pin Styles; Reference Ordering Information for Details
 Pin Style "L" is only available SS and MM port types.
 Pin Style "C" is only available SS, TP and MM port types.

BLOCK DIAGRAM

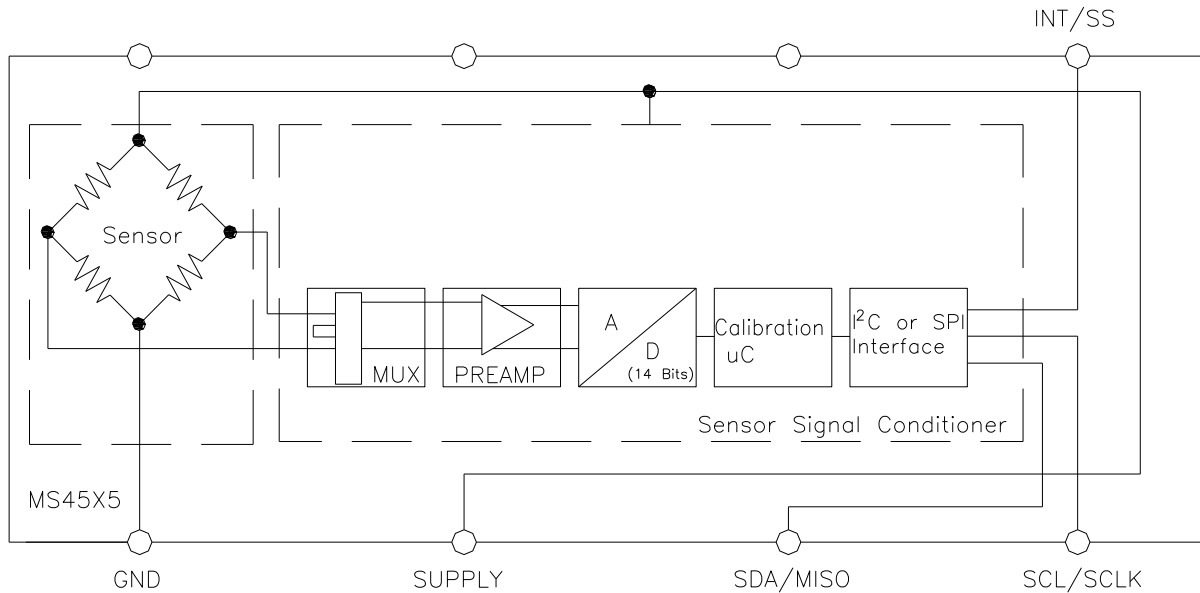

ABSOLUTE MAXIMUM RATINGS

Parameter	Conditions	Min	Max	Unit	Notes
Supply Voltage	T _A = 25 °C	2.7	5.5	V	
Output Current	T _A = 25°C		3	mA	
Storage Temperature		-40	+125	°C	
Humidity	T _A = 25°C		95	%RH	Non Condensing
Overpressure	T _A = 25 °C, both Ports	Not to Exceed 300		psi	
Burst Pressure	T _A = 25 °C, Port 1			psi	See Table 1
ESD	HBM	-4	+4	kV	EN 61000-4-2
Solder Temperature	250°C, 5 sec max.				

TABLE 1: BURST PRESSURE BY RANGE AND PACKAGE STYLE

Style	Port	002	004	005	010	020	030	Unit
DS,MM	Port 1	10	10	10	10	10	20	PSI
	Port 2	10	10	10	10	10	20	PSI
SS,TP	Port 1		10	10	10	10	20	PSI

ENVIRONMENTAL SPECIFICATIONS

Parameter	Conditions
Mechanical Shock	Mil Spec 202F, Method 213B, Condition C, 3 Drops
Mechanical Vibration	Mil Spec 202F, Method 214A, Condition 1E, 1Hr Each Axis
Thermal Shock	100 Cycles over Storage Temperature, 30 minute dwell
Life	1 Million FS Cycles
MTTF	>10Yrs, 70 °C, 1.188 Million Pressure Cycles, 120%FS Pressure

PERFORMANCE SPECIFICATIONS

Supply Voltage¹: 5.0V or 3.3 V_{DC}

Reference Temperature: 25°C (unless otherwise specified)

PARAMETERS	MIN	TYP	MAX	UNITS	NOTES
Output	51E 1EB		3AE0 3EB	Count Hex	1,2,3
Span	31EA 3852	3333 3998	347A 3AE0	%Span	1,2,3
Pressure Accuracy	-0.25		0.25	%Span	2
Total Error Band (TEB)	-1.0		1.0	%Span	3,7
TEB (4inH ₂ O and Below)	-2.0		2.0	%Span	3,7
Temperature Accuracy		1.5		°C	4
Supply Current		3		mA	7
Load Resistance (R _L)	10			kΩ	
Long Term stability (Offset & Span)		±0.5		%Span	
Compensated Temperature	0		+60	°C	5
Operating Temperature	-10		+85	°C	
Output Pressure Resolution			14	bits	
Output Temperature Resolution	8		11	bits	
Update Time		0.5		ms	6
Start Time to Data Ready			8.4	ms	6
Weight			3	grams	
Media	Non-Corrosive Dry Gases Compatible with Ceramic, Silicon, Borosilicate Glass, RTV, Gold, Aluminum and Epoxy. See "Wetted Material by Port Designation" chart below.				

Notes

- Proper operation requires an external capacitor placed as shown in Connection Diagram. Output is not ratiometric to supply voltage.
- The maximum deviation from a best fit straight line (BFSL) fitted to the output measured over the pressure range at 25C. Includes all errors due to pressure non linearity, hysteresis, and non-repeatability.
- Total pressure error band includes all accuracy errors, thermal errors over the compensated temperature range and span and offset calibration tolerances. For ideal sensor output with respect to input pressure and temperature, reference Transfer Function charts below. TEB values are valid only at the calibrated supply voltage.
- The deviation from a best fit straight line (BFSL) fitted to the output measured over the compensated temperature range.
- For errors beyond the compensated temperature range, see Extended Temperature Multiplier chart below.
- Start time to data ready is the time to get valid data after POR (power on reset). The time to get subsequent valid data is then specified by the update time specification.
- This product can be configured for custom OEM requirements, contact factory for lower power consumption or higher accuracy.

CONNECTION DIAGRAM

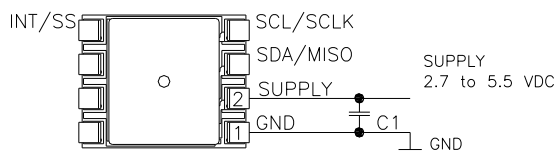

Notes

- Place 100nF capacitor between Supply and GND to within 2 cm of sensor.

PRESSURE AND TEMPERATURE TRANSFER FUNCTION

Pressure Transfer Functions

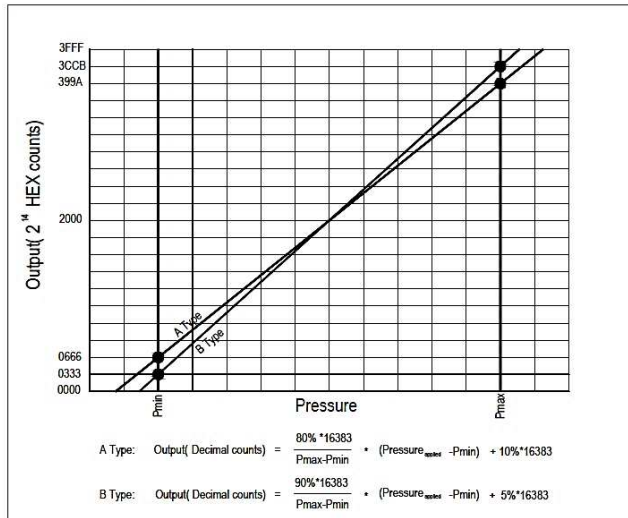

Temperature Transfer Functions

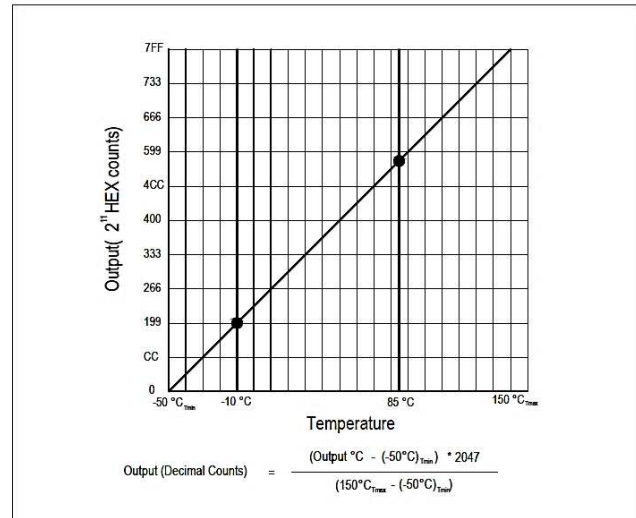

Sensor Output at Significant Percentages

% of Count	Output Type A (inH2O)	Output Type B (inH2O)	Digital Counts (decimal)	Digital Counts (hex)
0	$P_{\text{MIN}} - (P_{\text{MAX}} - P_{\text{MIN}}) \cdot 10/80$	$P_{\text{MIN}} - (P_{\text{MAX}} - P_{\text{MIN}}) \cdot 5/90$	0	0X0000
5		P_{MIN}	819	0X0333
10	P_{MIN}		1638	0X0666
50			8192	0X2000
90	P_{MAX}		14746	0X399A
95		P_{MAX}	15563	0X3CCB
100	$P_{\text{MAX}} + (P_{\text{MAX}} - P_{\text{MIN}}) \cdot 10/80$	$P_{\text{MAX}} + (P_{\text{MAX}} - P_{\text{MIN}}) \cdot 5/90$	16383	0X3FFF

Temperature Output vs Counts

OUTPUT (°C)	Digital Count (decimal)	Digital Counts (hex)
-50	0	0X0000
0	511	0X01FF
10	614	0X0266
25	767	0X02FF
50	1023	0X03FF
85	1381	0X0565
150	2047	0X07FF

EXTENDED TEMPERATURE MULTIPLIER CHART

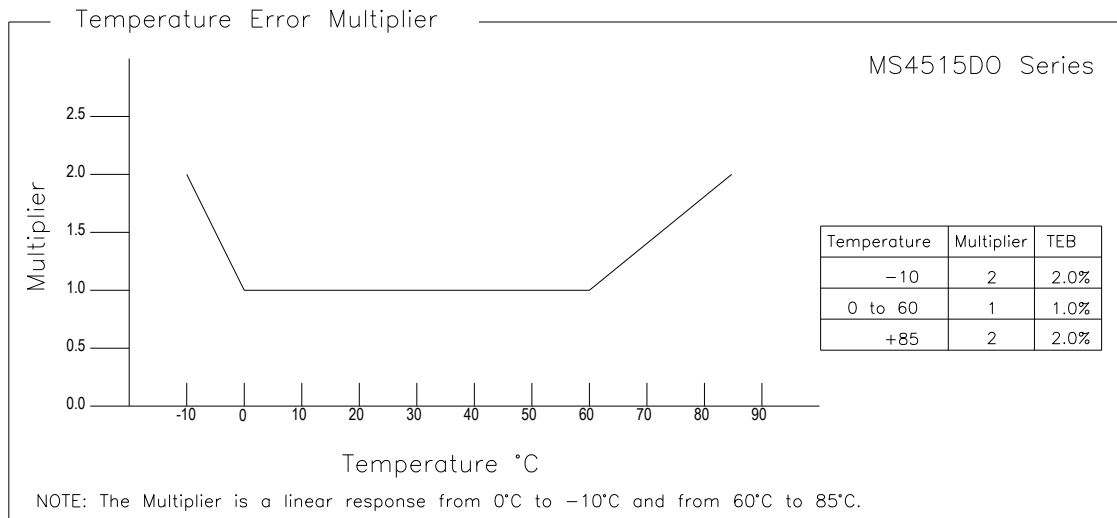

PACKAGE, PINOUT & PRESSURE TYPE CONFIGURATION

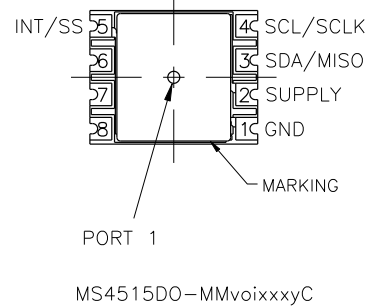
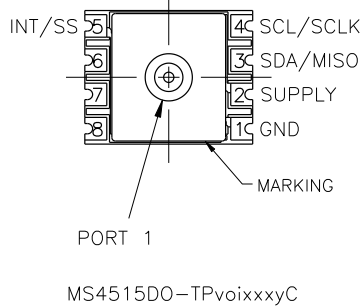
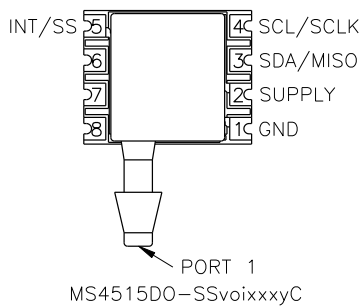
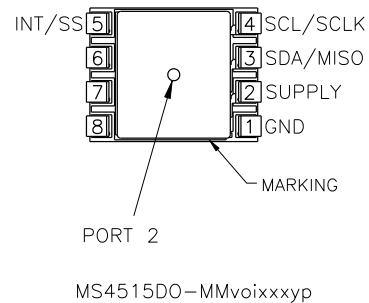
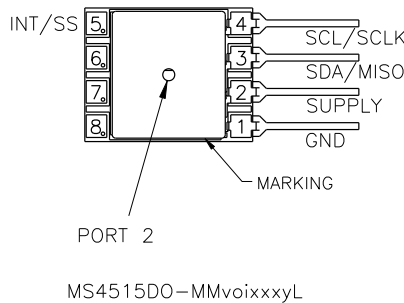
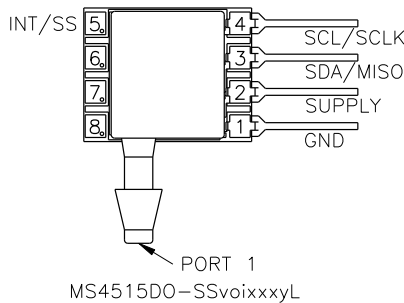
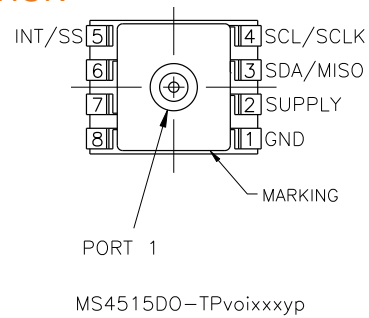
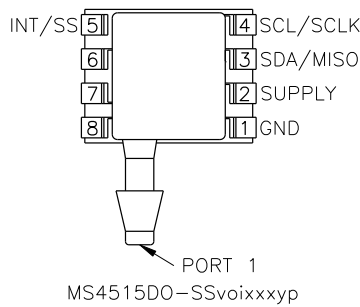
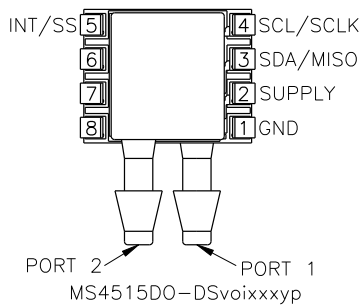

Pin Name	Pin	Function
GND	1	Ground
SUPPLY	2	Positive Supply Voltage
SDA	MISO	I ² C Data
SCL	SCLK	I ² C Clock
INT	SS	I ² C Interrupt
	6-8	No Connection

INT is not available for Pin Style "L" models

Pressure Type	P _{min}	P _{max}	Description
Differential/ Bidirectional	-P _{range}	+P _{range}	Output is proportional to the difference between Port 1 and Port 2. Output swings positive when Port 1 > Port 2. Output is 50% of total counts when Port 1=Port 2
Gauge	0psiG	+P _{range}	Output is proportional to the difference between 0psiG (P _{min}) and Port 1. Output swings positive when Port 1 > Port 2.

P_{range} is equal to the maximum full scale pressure specified in the ordering information.

Standard Range (inH₂O) by port style

WETTED MATERIAL BY PORT DESIGNATION

Style	Port	Material							
		Ceramic	Silicon	Borosilicate	Glass	RTV	Gold	Aluminum	Epoxy
DS, MM	Port 1	X	X	X	X	X			X
	Port 2	X	X	X	X	X	X	X	X
SS, TP, SM	Port 1	X	X	X	X	X	X	X	X

"X" Indicates Wetted Material

I²C INTERFACE

I²C Interface Parameters

Parameters	Symbol	Min	Typ	Max	Units
SCLK Clock Frequency	F _{SCL}	100		400	kHz
Start Condition hold time relative to SCL edge	t _{HDSTA}	0.1			μs
Minimum SCL clock low width ¹	t _{LOW}	0.6			μs
Minimum SCL clock high width ¹	t _{HIGH}	0.6			μs
Start Condition Setup time relative to SCL edge	t _{SUSTA}	0.1			μs
Data hold time on SDA relative to SCL edge	t _{HDDAT}	0			μs
Data setup time on SDA relative to SCL edge	t _{SUDAT}	0.1			μs
Stop condition setup time on SCL	t _{SUSTO}	0.1			μs
Bus free time between stop and start condition	t _{BUS}	2			μs

¹ combined low and high widths must equal or exceed minimum SCL period

I²C INTERFACE TIMING DIAGRAM

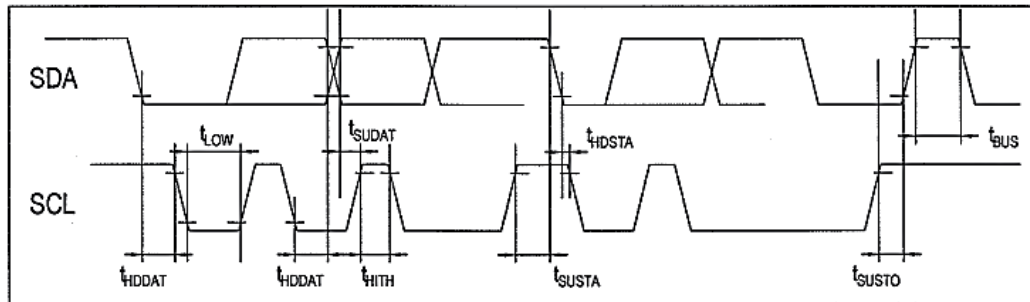

SPI INTERFACE

SPI Interface Parameters

Parameters	Symbol	Min	Typ	Max	Units
SCLK Clock Frequency	F _{SCL}	50		800	kHz
SS Drop to First clock edge	t _{HDSS}	2.5			μs
Minimum SCL clock low width @1	t _{LOW}	0.6			μs
Minimum SCL clock high width @1	t _{HIGH}	0.6			μs
Clock Edge to data transition	t _{CLKD}	0		0.1	μs
Rise of SS relative to last clock edge	t _{SUSS}	0.1			μs
Bus free time rise and fall of SS	t _{BUS}	2			μs

@1 combined low and high widths must equal or exceed minimum SCLK period

SPI INTERFACE TIMING DIAGRAM

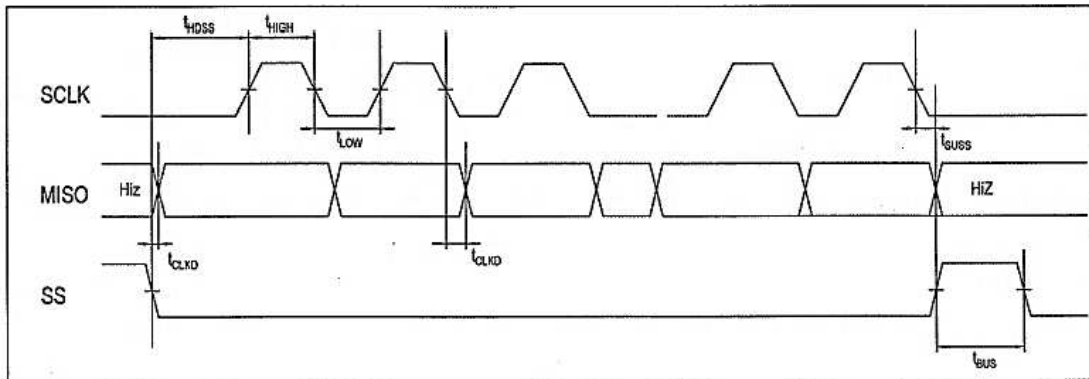

DIMENSIONS

Dimensions are in INCHES [mm]

Model: MS4515DO-DSvoixxyP

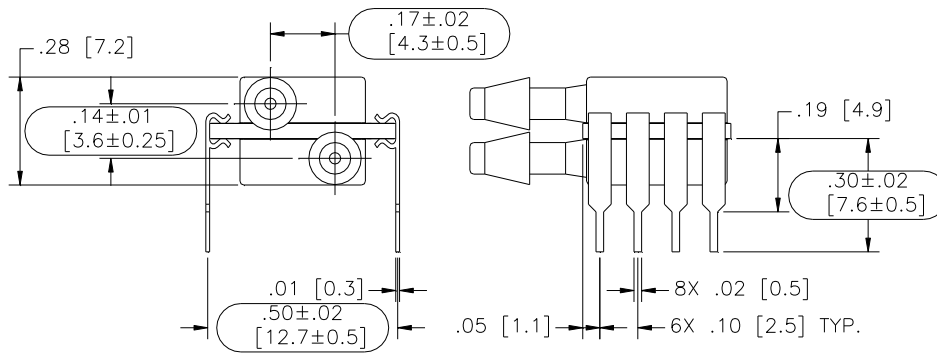
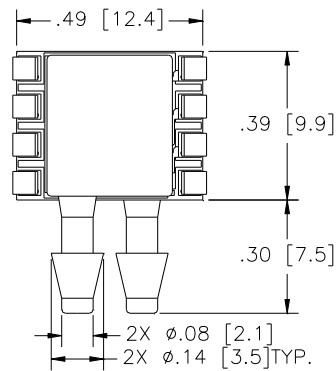

Model: MS4515DO-DSvoixxyS

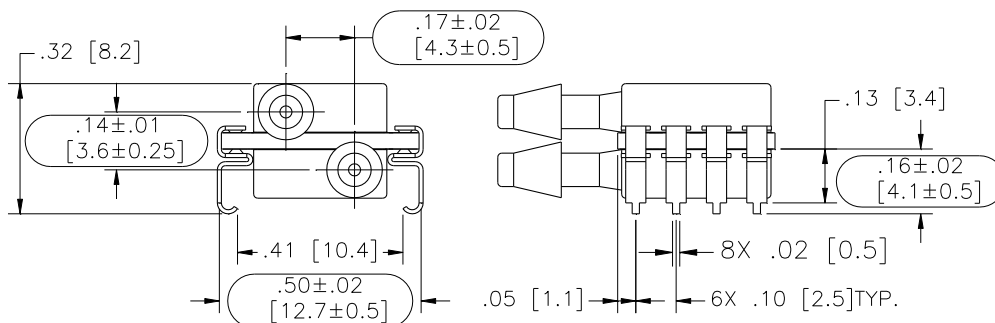
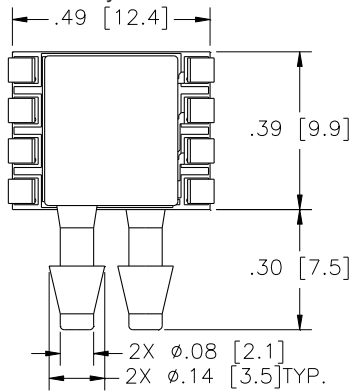

Model: MS4515DO-SSvoixxyP

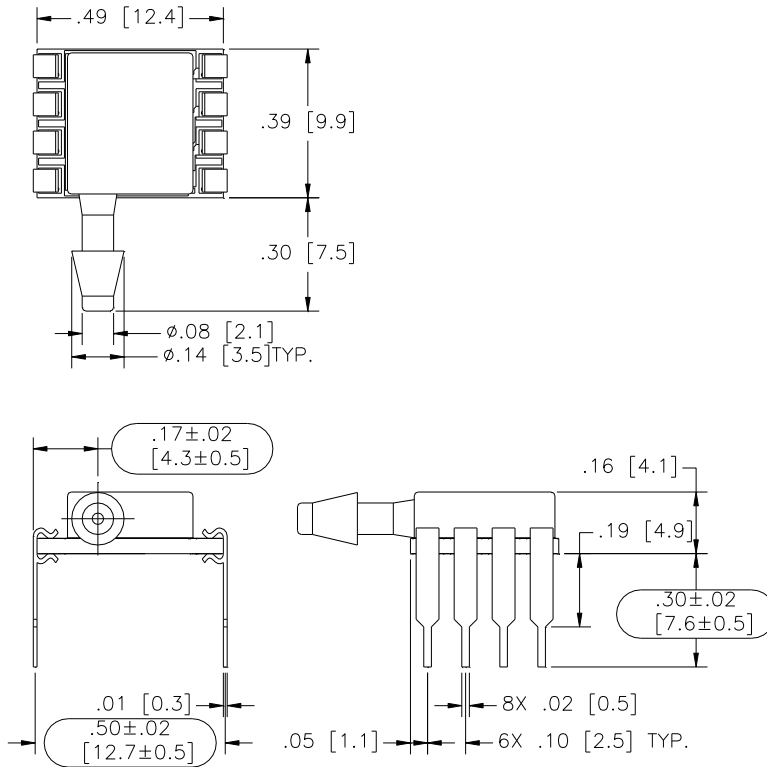

Model: MS4515DO-SSvoixxyS

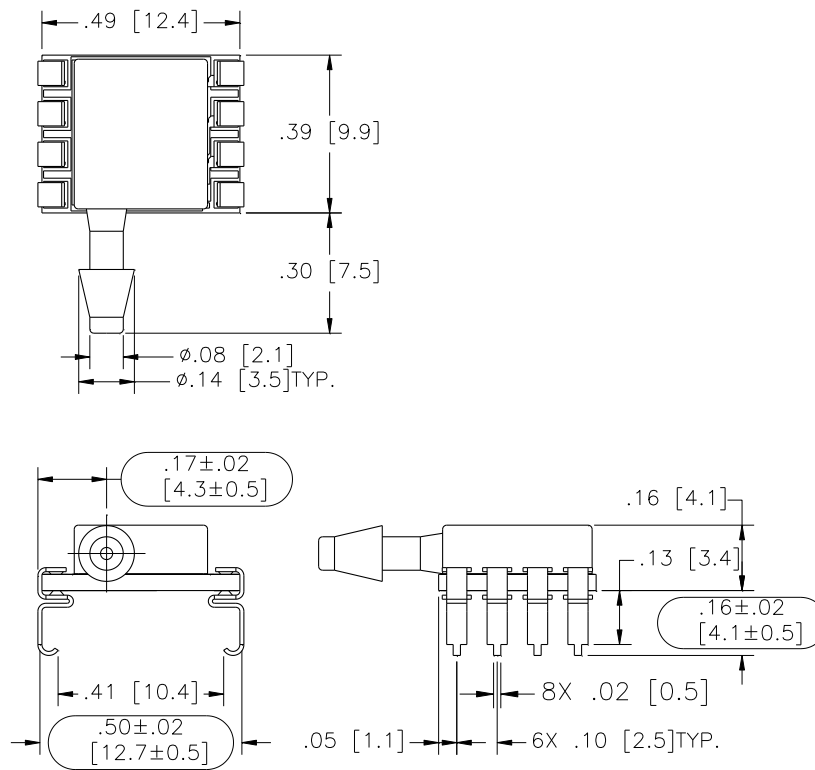

Model: MS4515DO-TPvoixxyP

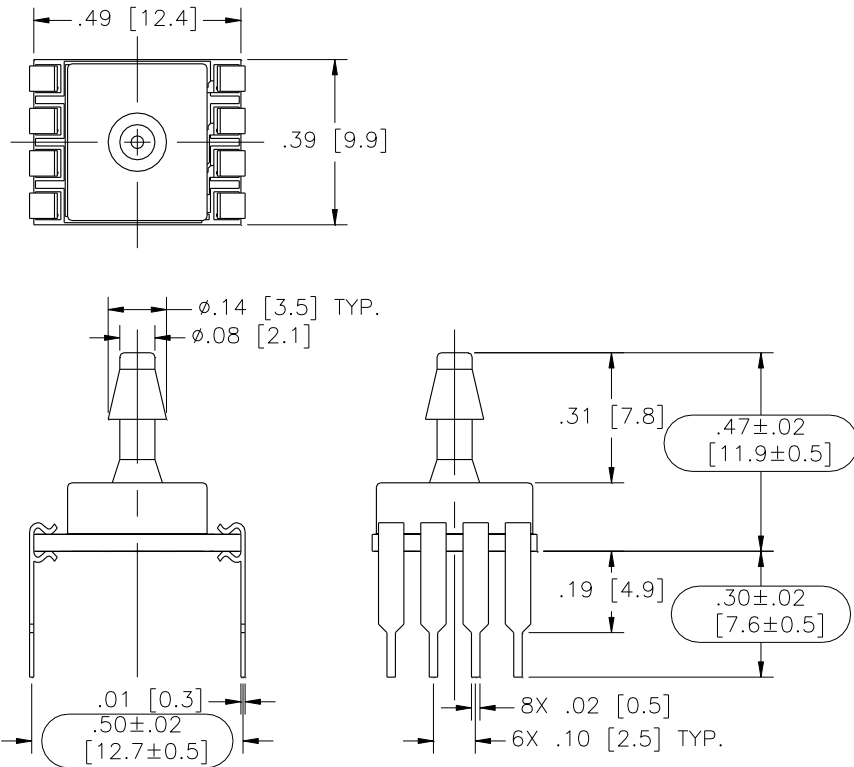

Model: MS4515DO-TPvoixxyS

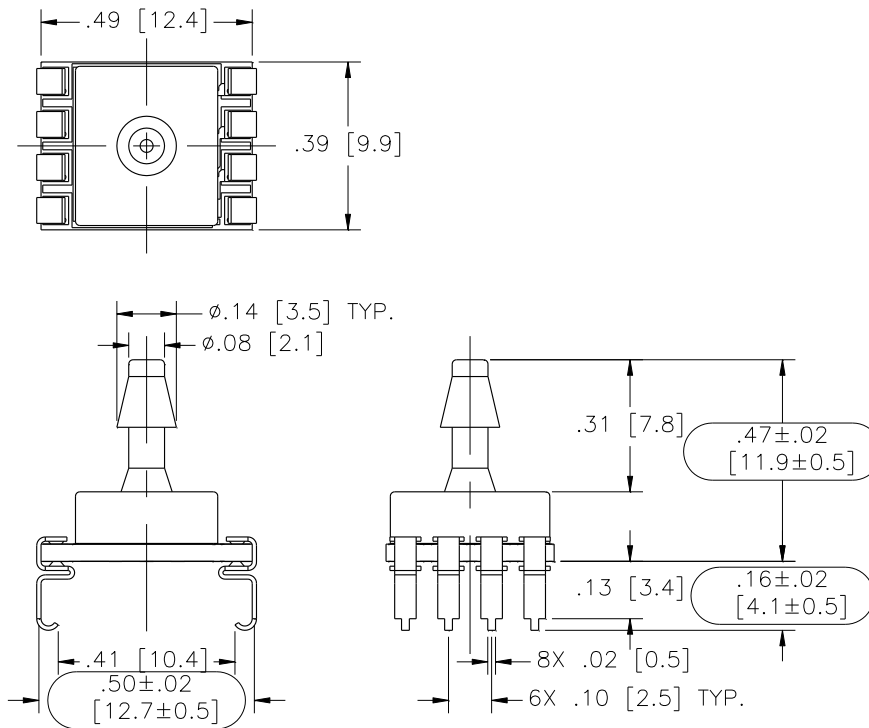

Model: MS4515DO-SSvoixxyL

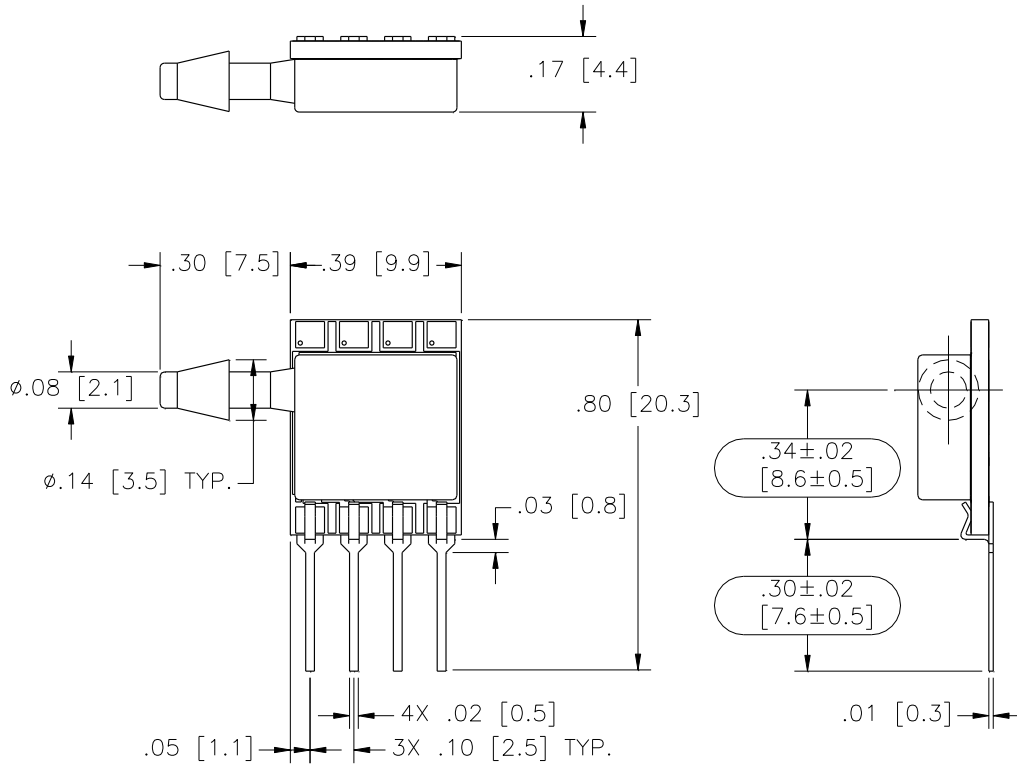

Model: MS4515DO-MMvoixxyL

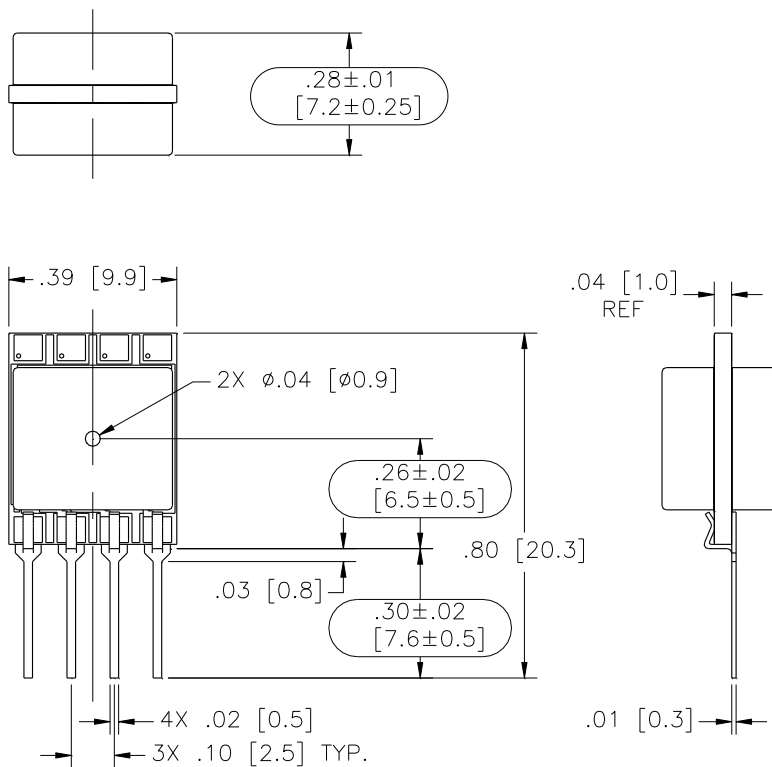

Model: MS4515DO-MMvoixxyP

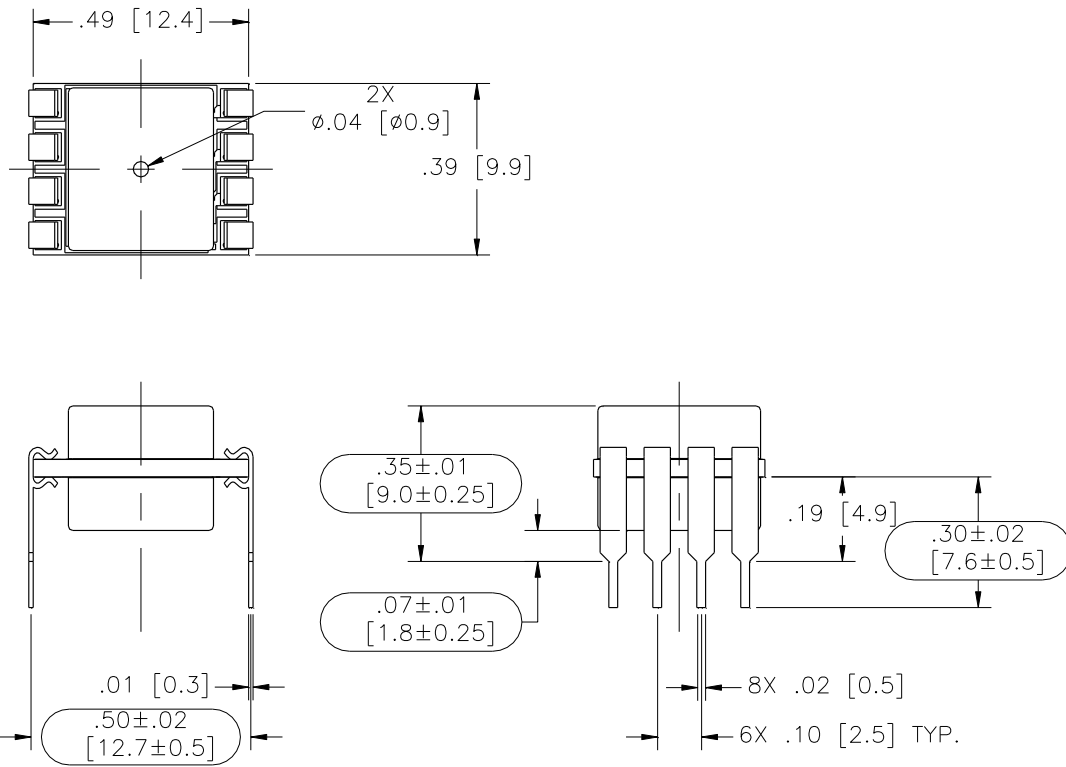

Model: MS4515DO-MMvoixxyS

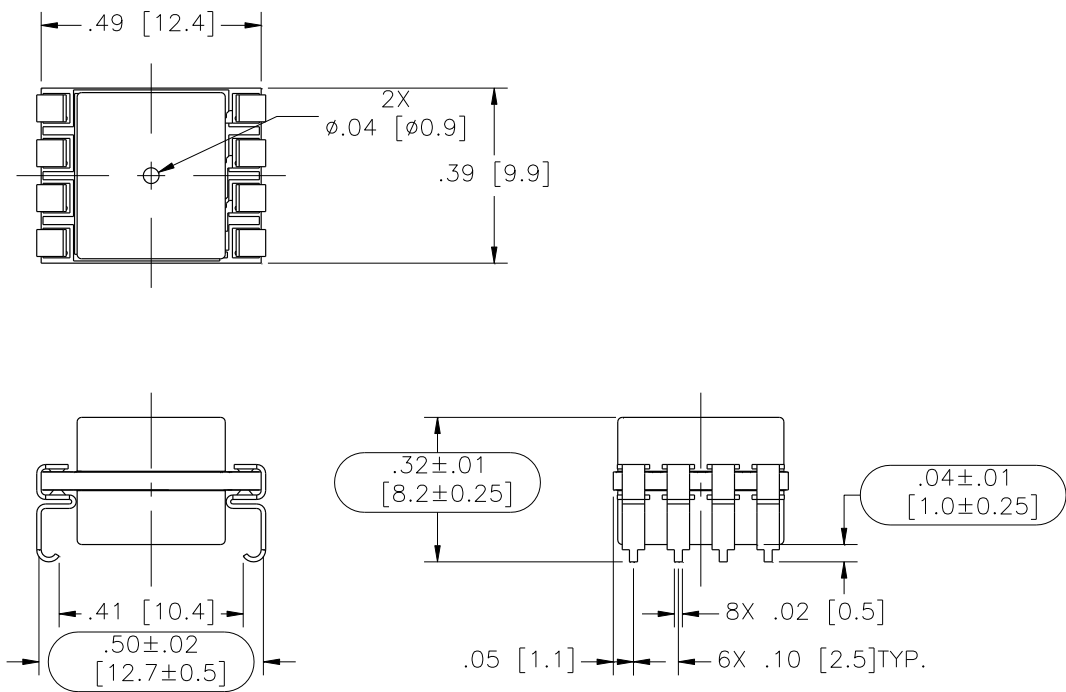

Model: MS4515DO-SSvoixxyC

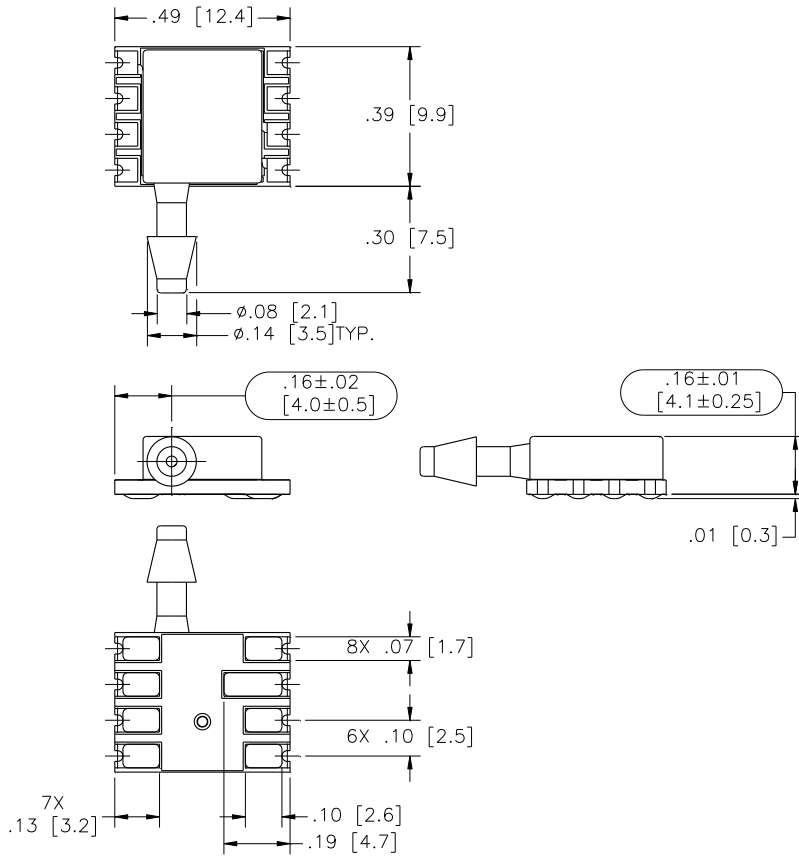

Model: MS4515DO-TPvoixxyC

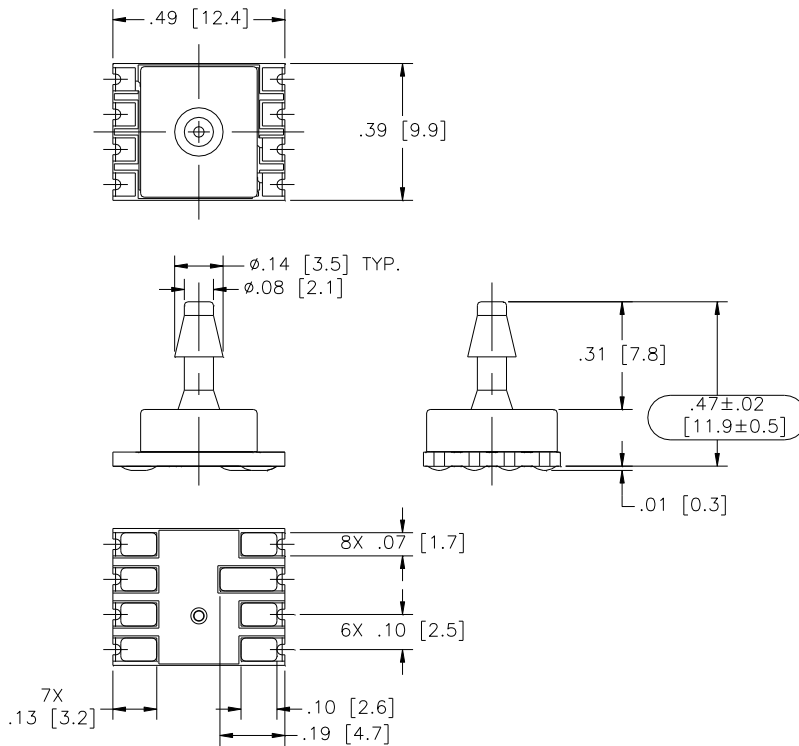

Model: MS4515DO-MMvoixxyC

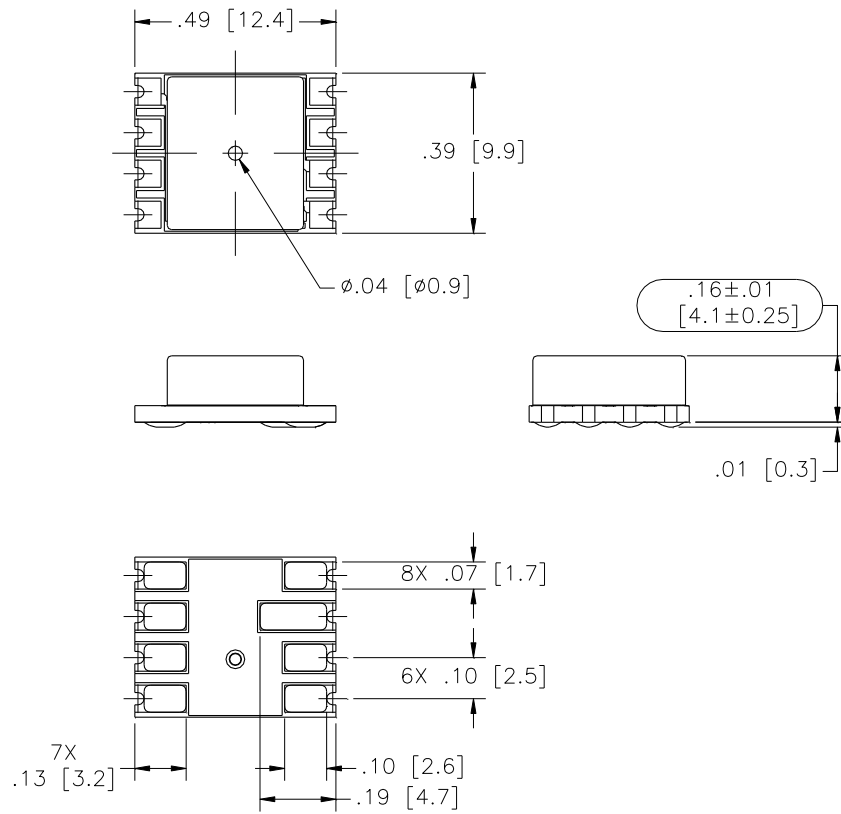

APPLICATION NOTES

Measurement Specialties offers a comprehensive selection of product support documentation.

MS45xx Series Application Note

- Bypass Capacitor Selection
- Pressure Hose Recommendations
- PCB Layout Recommendations

Interfacing to MEAS Digital Pressure Modules

- I²C or SPI Protocol Description
- Data Fetch, Measurement Request Commands
- Timing Diagrams

Configuration, POR and Power Consumption

- Standard and Low Power Configuration
- Power On Reset (POR)
- Current Consumption by Sampling Frequency

AVAILABLE OPTIONS

Gel Coat (-F Option)

The MS4515DO is designed for non-ionic and clean dry air applications. Select this option for added protection in high humidity or slightly corrosive environments with the application of a silicone gel elastomer to sensor and ASIC. For questions concerning media compatibility, contact the factory.

Low Power (-L Option)

Select this option for battery powered or handheld device applications. In this configuration, the sensor and calibration microcontroller are powered down, drawing a current of ~ 0.6uA ($V_s=5.0 V_{DC}$). When the master sends a **Read MR** (measurement request) command (I²C or SPI); the sensor is “awaken” and begins the measurement cycle; data is then placed onto the output registers. The sensor and calibration microcontroller are powered down again, awaiting the **Read DF** (data fetch) command from the master.

ORDERING INFORMATION

4515DO – DS 3 B K 030 D P M

Package Type	
SS	Single Sideport
DS	Dual Sideport
TP	Top Port
MM	Manifold Mount

Supply Voltage	
3	3.3 V _{DC}
5	5.0 V _{DC}

Output Type	
A	10% to 90%
B	5% to 95%

Interface Type	
I	I ² C (Addr. 0x28H)
J	I ² C (Addr. 0x36H)
K	I ² C (Addr. 0x46H)
S	SPI (Not available for 'L' pin Style)
0	I ² C (Addr. 0x48H)
:	:
9	I ² C (Addr. 0x51H)

Option Type	
[Blank]	No Option
F*	Gel Coating
L	Low Power
M*	Gel Coat & Low Power

* Options available for pressure ranges ≥ 10 inH₂O

Pin Type	
P	Thru Hole
S	J Lead
L	In Line
C	Castellation

Pressure Type	
D	Differential
G	Gauge

Pressure Range [inH ₂ O]	
	002
	004
	005
	010
	020
	030

NORTH AMERICA

Measurement Specialties, Inc.,
a TE Connectivity company
Tel: +1 800-522-6752
Email: customercare.frmt@te.com

EUROPE

Measurement Specialties (Europe), Ltd.,
a TE Connectivity Company
Tel: +31 73 624 6999
Email: customercare.bevx@te.com

ASIA

Measurement Specialties (China) Ltd.,
a TE Connectivity company
Tel: +86 0400-820-6015
Email: customercare.shzn@te.com

TE.com/sensorsolutions

Measurement Specialties, Inc., a TE Connectivity company.

Measurement Specialties, TE Connectivity, TE Connectivity (logo) and EVERY CONNECTION COUNTS are trademarks. All other logos, products and/or company names referred to herein might be trademarks of their respective owners.

The information given herein, including drawings, illustrations and schematics which are intended for illustration purposes only, is believed to be reliable. However, TE Connectivity makes no warranties as to its accuracy or completeness and disclaims any liability in connection with its use. TE Connectivity's obligations shall only be as set forth in TE Connectivity's Standard Terms and Conditions of Sale for this product and in no case will TE Connectivity be liable for any incidental, indirect or consequential damages arising out of the sale, resale, use or misuse of the product. Users of TE Connectivity products should make their own evaluation to determine the suitability of each such product for the specific application.

© 2015 TE Connectivity Ltd. family of companies All Rights Reserved.

X-ON Electronics

Largest Supplier of Electrical and Electronic Components

Click to view similar products for te connectivity manufacturer:

Other Similar products are found below :

[570416-000](#) [CLTEQ-M81CE-SSRELAY-4-20V](#) [4-1633138-8](#) [D38999/24FJ4AN](#) [4-1195131-0](#) [650069-000](#) [SMD100-2](#) [2EDL4CM](#)
[DTS20W19-11PD-3028](#) [DTS20W19-11PD-3028-LC](#) [DTS20W19-32SD-3028-LC](#) [DTS20W19-32SD-3028](#) [NC6-P104-06](#) [TXR64AB90-](#)
[3616AI](#) [DTS26F21-41HE](#) [DTS26F21-41AE](#) [DTS26F21-41PE-LC](#) [DTS26F21-11SE-3028-LC](#) [D38999/24WF32JE](#) [D38999/24WF32SE-LC](#)
[DTS24W19-32HE](#) [D38999/20JB35HA](#) [D38999/24WJ20PA](#) [164-8033-08](#) [D38999/24FF32JE](#) [D38999/24FF32SE-LC](#) [D38999/24WF32JB](#)
[D38999/24WG11HA](#) [D38999/24WG11HN](#) [MS27467T21F11H](#) [DJT16E21-11HA](#) [DTS24F19-32HE](#) [DTS20W19-32SA-3028-LC](#) [DTS24F19-](#)
[11SC-3028-LC](#) [DTS24F19-11SC-3028](#) [DJT14E13-98HB](#) [D38999/20WC8BB](#) [1-330599-5](#) [DTS24F21-41HN-LC](#) [DTS24F21-41HN](#)
[DTS24F21-41AN](#) [DTS24F21-39HN](#) [DTS24F21-41PN-LC](#) [AFD50-10-6SN-1A-LC](#) [DJT10F17-26HC](#) [DTS24W19-32HB](#) [ACT20JE99HA](#)
[DJT10E17-26HC](#) [DJT10E17-26HN](#) [DJT10F17-26HA](#)