

PROPER USE GUIDELINES

Cumulative Trauma Disorders can result from the prolonged use of manually powered hand tools. Hand tools are intended for occasional use and low volume applications. A wide selection of powered application equipment for extended-use, production operations is available.

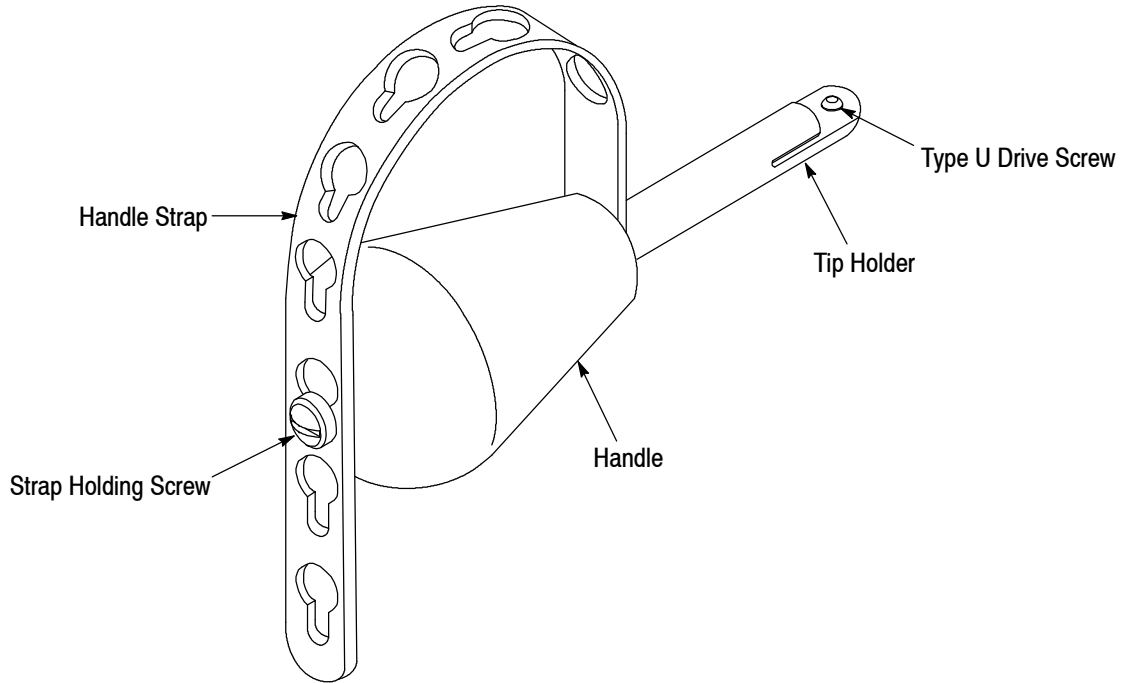

TIP	INSTRUCTION SHEET	PRODUCT
465645-[]	408-9749	Wrap Type Tab Receptacle Contact
465665-1	408-9580	250 Series FASTIN-FASTON* Terminal
465468-[]	408-7144	110, 187, 205, and 250 Series FASTON* Terminals (With Wire Insulation Diameter or Crimp Width of 2.41 mm [.095 in.] or Less)
		All Tab-Lok Flag FASTON Terminals
465488-[]	408-7144	110, 187, 205, and 250 Series FASTON Terminals (With Wire Insulation Diameter or Crimp Width Over 2.41 mm [.095 in.]

Figure 1

1. INTRODUCTION

Universal Hand Tool Assemblies 465629-1 and -2 are used with the tips listed in Figure 1 to insert or extract the products also listed in Figure 1. The tips are not included with the tool. Refer to the tip instruction sheet for the product insertion or extraction procedure.

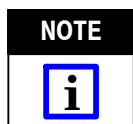

Dimensions in this instruction sheet are in metric units [with U.S. customary units in brackets]. Figures are not drawn to scale.

Reasons for reissue of this instruction sheet are provided in Section 6, REVISION SUMMARY.

2. DESCRIPTION

The hand tool assembly consists of a handle, handle strap, strap holding screw, tip holder, and Type U drive screw. The tip holder of Tool -1 is shorter than that of Tool -2 to accommodate the depth of the application (refer to Figure 3 for length).

3. USING THE TOOL

3.1. Adjusting the Handle Strap

1. Move the strap so that the wide part of the hole is under the strap holding screw.
2. Lift the strap off the strap holding screw, and adjust it to the size desired.

3.2. Installing the Tip

1. Select the proper tip according to Figure 1.
2. Place the tip on the tool tip holder so that the slot fits through the Type U drive screw of the tip holder. See Figure 2.
3. Keeping the tip and tip holder aligned, push the tip toward the tool until the tip locks in the tip holder.

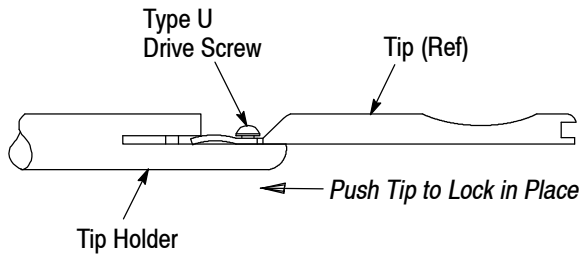

Figure 2

3.3. Removing the Tip

To remove the tip from the tool, pull the tip straight from of the tip holder, and lift it off of the Type U drive screw.

4. MAINTENANCE AND INSPECTION

Ensure that the tool is clean and undamaged, and that no contaminants become lodged in the tip holder. The tool should be inspected before each use.

5. REPLACEMENT AND REPAIR

Customer-replaceable parts are provided in Figure 3. A complete inventory should be stocked and controlled to prevent lost time when replacement of parts is necessary. Parts other than those listed are not repairable. Order replacement parts or new tools through your TE Connectivity Representative, or call 1-800-526-5142, or send a facsimile of your purchase order to 717-986-7605, or write to:

CUSTOMER SERVICE (038-035)
 TYCO ELECTRONICS CORPORATION
 PO BOX 3608
 HARRISBURG PA 17105-3608

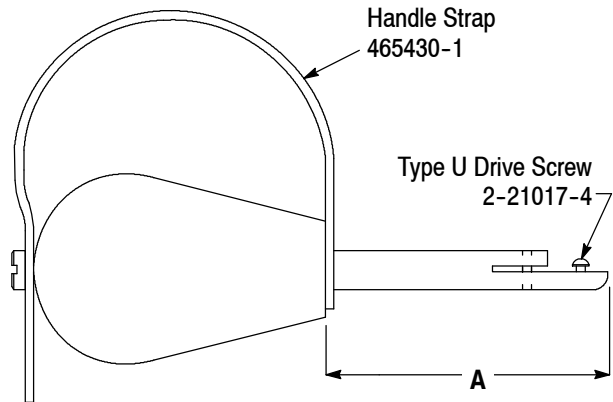

TOOL	DIMENSION A
465629-1	47.5 [1.87]
465629-2	149.1 [5.87]

Figure 3

6. REVISION SUMMARY

- New logo

X-ON Electronics

Largest Supplier of Electrical and Electronic Components

Click to view similar products for [Extraction, Removal & Insertion Tools](#) category:

Click to view products by [TE Connectivity](#) manufacturer:

Other Similar products are found below :

[M8196914-08](#) [768211-2](#) [809-131](#) [844751-2](#) [8-59558-2](#) [91018-1](#) [12014013](#) [12093647](#) [1-21048-0](#) [R282867020](#) [12093078](#) [1-21048-6](#)
[12121897](#) [DCF.91.405.5LT](#) [1322](#) [15314260](#) [15350698](#) [15350707](#) [15430130](#) [1579018-4](#) [1643916-1](#) [1-679532-0](#) [1976593-3](#) [OUTEXT-0321](#)
[2-1579008-3](#) [2-1579008-4](#) [229694-7](#) [231106-1](#) [241469](#) [91040-3](#) [91040-7](#) [965004-000](#) [965069-000](#) [1738219-1](#) [ET-JL05-16](#) [FG 0300 146](#)
[3000](#) [FIT-6](#) [210S048](#) [2-1579007-9](#) [231879-1](#) [312138-3](#) [RJ11FODE](#) [356-162](#) [M8196914-10](#) [4-1579018-0](#) [430395-001](#) [483249-1](#) [5-](#)
[1579007-2](#) [5-1579007-9](#) [BPR10](#)