

- TRUE POSITION TOLERANCE OF THE POST TIPS WHEN THE HEADER IS HELD FLAT AGAINST THE PRINTED CIRCUIT BOARD.
- THE NOTED DIMENSIONS APPLY AT THE INTERSECTION OF THE POST AND HOUSING.
- RETENTION FEATURES ON SOLDER TAILS, LOCATED AT MANUFACTURERS OPTION.
- HOUSING: LCP, COLOR-BLACK. POST: COPPER ALLOY.
- 0.000762[.000030] GOLD IN CONTACT AREA, 0.00254-0.00508 [.0000100-.0000200] MATTE TIN-LEAD ON SOLDER TAIL, ALL OVER 0.00127 [.000050] NICKEL.
- THIS DIMENSION WILL BE 4.67[.184] FOR THE 2 POSITION CONFIGURATION
- 0.000762[.000030] GOLD IN CONTACT AREA, 0.00254-0.00508 [.0000100-.0000200] MATTE TIN ON SOLDER TAIL, ALL OVER 0.00127 [.000050] NICKEL.
- OBSOLETE PARTS: OBSOLETE CIS STREAMLINING PER D.RENAUD/D.SINISI

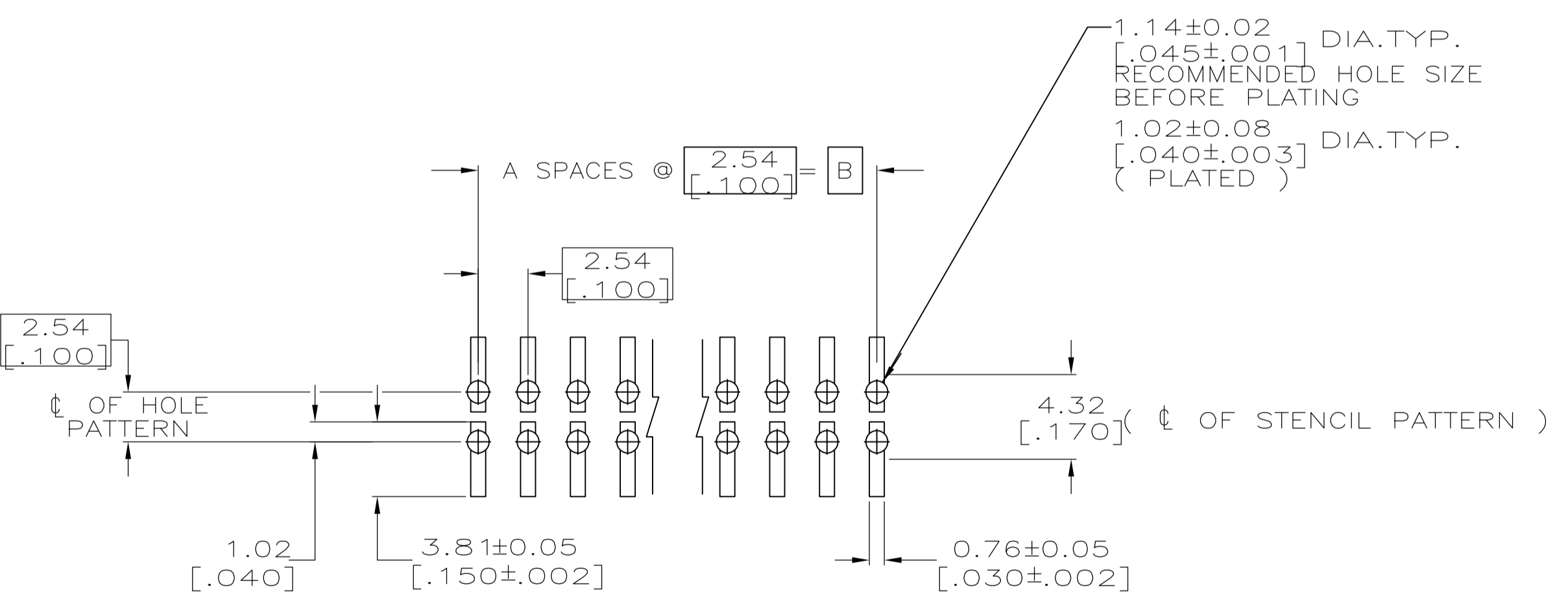
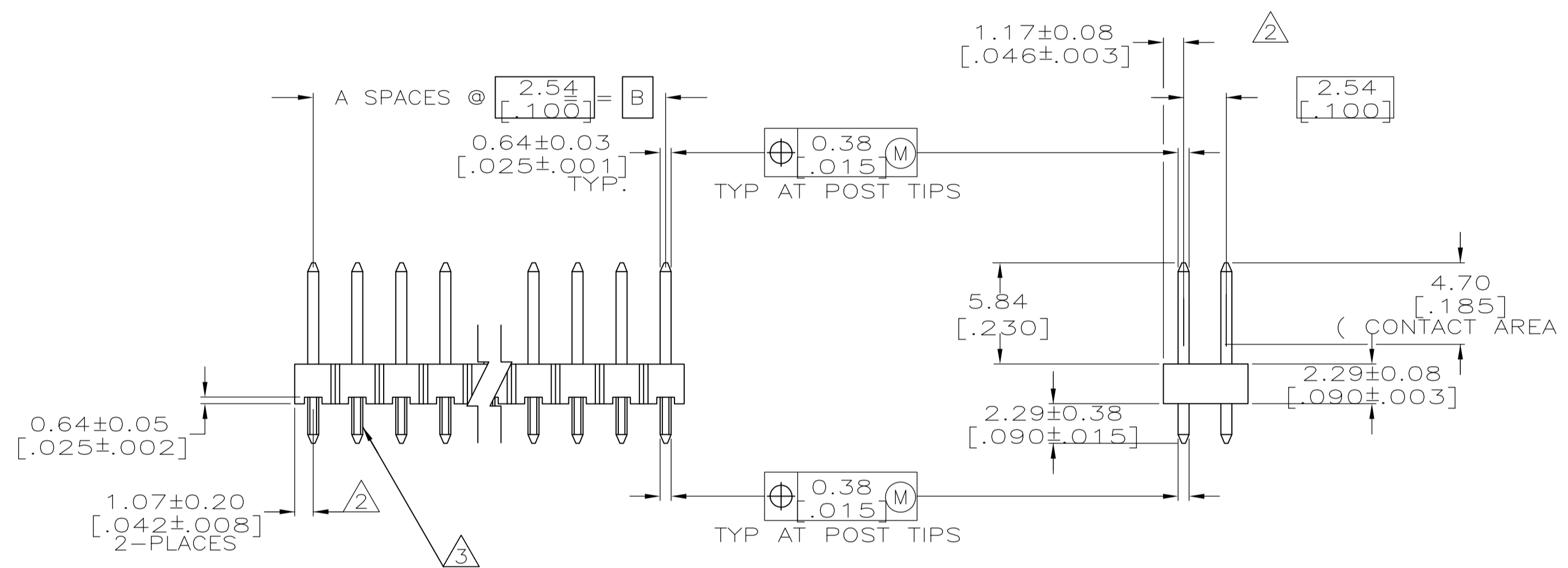
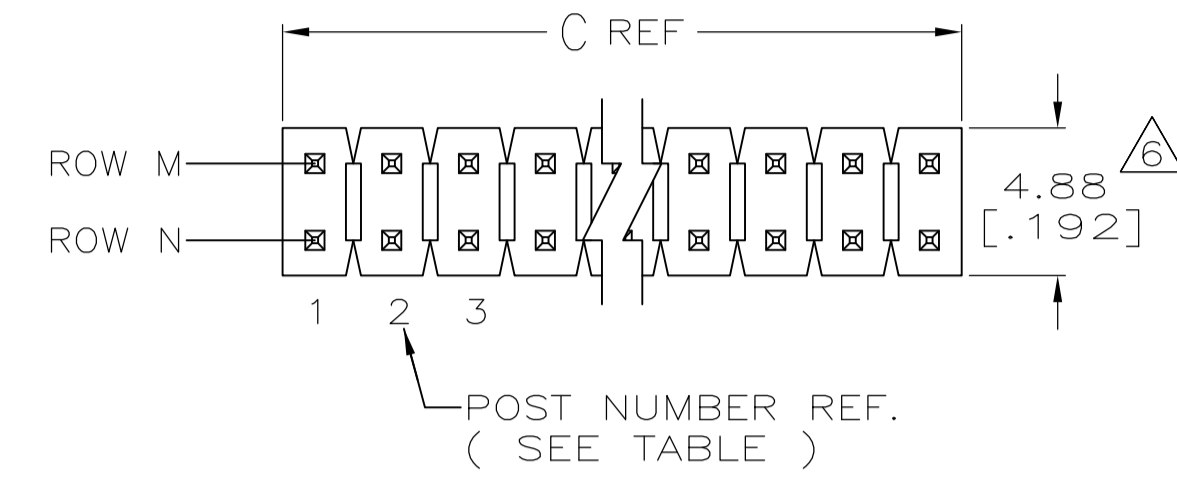

RECOMMENDED PC BOARD MOUNTING DIMENSIONS FOR .063 [1.60] THICK PC BOARD AND .012 [.305] STENCIL THICK.

FINISH	C	B	A	NO. OF POSITIONS	PART NUMBER
7	101.19 [3.984]	99.06 [3.900]	39	80	9-146273-0
7	98.65 [3.884]	96.52 [3.800]	38	78	8-146273-9
7	96.11 [3.784]	93.98 [3.700]	37	76	8-146273-8
7	93.57 [3.684]	91.44 [3.600]	36	74	8-146273-7
7	91.03 [3.584]	88.90 [3.500]	35	72	8-146273-6
7	88.49 [3.484]	86.36 [3.400]	34	70	8-146273-5
7	85.95 [3.384]	83.82 [3.300]	33	68	8-146273-4
7	83.41 [3.284]	81.28 [3.200]	32	66	8-146273-3
7	80.87 [3.184]	78.74 [3.100]	31	64	8-146273-2
7	78.33 [3.084]	76.20 [3.000]	30	62	8-146273-1
7	75.79 [2.984]	73.66 [2.900]	29	60	8-146273-0
7	73.25 [2.884]	71.12 [2.800]	28	58	7-146273-9
7	70.71 [2.784]	68.58 [2.700]	27	56	7-146273-8
7	68.17 [2.684]	66.04 [2.600]	26	54	7-146273-7
7	65.63 [2.584]	63.50 [2.500]	25	52	7-146273-6
7	63.09 [2.484]	60.96 [2.400]	24	50	7-146273-5
7	60.55 [2.384]	58.42 [2.300]	23	48	7-146273-4
7	58.01 [2.284]	55.88 [2.200]	22	46	7-146273-3
7	55.47 [2.184]	53.34 [2.100]	21	44	7-146273-2
7	52.93 [2.084]	50.80 [2.000]	20	42	7-146273-1
7	50.39 [1.984]	48.26 [1.900]	19	40	7-146273-0
7	47.85 [1.884]	45.72 [1.800]	18	38	6-146273-9
7	45.31 [1.784]	43.18 [1.700]	17	36	6-146273-8
7	42.77 [1.684]	40.64 [1.600]	16	34	6-146273-7
7	40.23 [1.584]	38.10 [1.500]	15	32	6-146273-6
7	37.69 [1.484]	35.56 [1.400]	14	30	6-146273-5
7	35.15 [1.384]	33.02 [1.300]	13	28	6-146273-4
7	32.61 [1.284]	30.48 [1.200]	12	26	6-146273-3
7	30.07 [1.184]	27.94 [1.100]	11	24	6-146273-2
7	27.53 [1.084]	25.40 [1.000]	10	22	6-146273-1
7	24.99 [0.984]	22.86 [0.900]	9	20	6-146273-0
7	22.45 [0.884]	20.32 [0.800]	8	18	5-146273-9
7	19.91 [0.784]	17.78 [0.700]	7	16	5-146273-8
7	17.37 [0.684]	15.24 [0.600]	6	14	5-146273-7
7	14.83 [0.584]	12.70 [0.500]	5	12	5-146273-6
7	12.29 [0.484]	10.16 [0.400]	4	10	5-146273-5
7	9.75 [0.384]	7.62 [0.300]	3	8	5-146273-4
7	7.21 [0.284]	5.08 [0.200]	2	6	5-146273-3
7	4.67 [0.184]	2.54 [0.100]	1	4	5-146273-2
7	2.33 [0.092]	-	-	2	5-146273-1

FINISH	C	B	A	NO. OF POSITIONS	PART NUMBER
5	101.19 [3.984]	99.06 [3.900]	39	80	4-146273-0
5	98.65 [3.884]	96.52 [3.800]	38	78	3-146273-9
5	96.11 [3.784]	93.98 [3.700]	37	76	3-146273-8
5	93.57 [3.684]	91.44 [3.600]	36	74	3-146273-7
5	91.03 [3.584]	88.90 [3.500]	35	72	3-146273-6
5	88.49 [3.484]	86.36 [3.400]	34	70	3-146273-5
5	85.95 [3.384]	83.82 [3.300]	33	68	3-146273-4
5	83.41 [3.284]	81.28 [3.200]	32	66	3-146273-3
5	80.87 [3.184]	78.74 [3.100]	31	64	3-146273-2
5	78.33 [3.084]	76.20 [3.000]	30	62	3-146273-1
5	75.79 [2.984]	73.66 [2.900]	29	60	3-146273-0
5	73.25 [2.884]	71.12 [2.800]	28	58	2-146273-9
5	70.71 [2.784]	68.58 [2.700]	27	56	2-146273-8
5	68.17 [2.684]	66.04 [2.600]	26	54	2-146273-7
5	65.63 [2.584]	63.50 [2.500]	25	52	2-146273-6
5	63.09 [2.484]	60.96 [2.400]	24	50	2-146273-5
5	60.55 [2.384]	58.42 [2.300]	23	48	2-146273-4
5	58.01 [2.284]	55.88 [2.200]	22	46	2-146273-3
5	55.47 [2.184]	53.34 [2.100]	21	44	2-146273-2
5	52.93 [2.084]	50.80 [2.000]	20	42	2-146273-1
5	50.39 [1.984]	48.26 [1.900]	19	40	2-146273-0
5	47.85 [1.884]	45.72 [1.800]	18	38	1-146273-9
5	45.31 [1.784]	43.18 [1.700]	17	36	1-146273-8
5	42.77 [1.684]	40.64 [1.600]	16	34	1-146273-7
5	40.23 [1.584]	38.10 [1.500]	15	32	1-146273-6
5	37.69 [1.484]	35.56 [1.400]	14	30	1-146273-5
5	35.15 [1.384]	33.02 [1.300]	13	28	1-146273-4
5	32.61 [1.284]	30.48 [1.200]	12	26	1-146273-3
5	30.07 [1.184]	27.94 [1.100]	11	24	1-146273-2
5	27.53 [1.084]	25.40 [1.000]	10	22	1-146273-1
5	24.99 [0.984]	22.86 [0.900]	9	20	1-146273-0
5	22.45 [0.884]	20.32 [0.800]	8	18	146273-9
5	19.91 [0.784]	17.78 [0.700]	7	16	146273-8
5	17.37 [0.684]	15.24 [0.600]	6	14	146273-7
5	14.83 [0.584]	12.70 [0.500]	5	12	146273-6
5	12.29 [0.484]	10.16 [0.400]	4	10	146273-5
5	9.75 [0.384]	7.62 [0.300]	3	8	146273-4
5	7.21 [0.284]	5.08 [0.200]	2	6	146273-3
5	4.67 [0.184]	2.54 [0.100]	1	4	146273-2
5	2.33 [0.092]	-	-	2	146273-1

OBSOLETE 8

THIS DRAWING IS A CONTROLLED DOCUMENT.

DIMENSIONS: mm [INCHES]	TOLERANCES UNLESS OTHERWISE SPECIFIED:	0 PLC ± -	1 PLC ± 0.15[.005]	2 PLC ± 0.25[.010]	3 PLC ± 0.38[.015]	4 PLC ± 0.51[.020]	ANGLES ± 0.127[.005]
MATERIAL	SEE TABLE	WEIGHT	-	SIZE	A1	CAGE CODE	00779
CUSTOMER DRAWING		SCALE	4:1	SHEET	1 of 1	REV	K

DWN T. HOFFMAN 5/8/95
 CHK G. DUBNICZKI 3/4/96
 APVD G. DUBNICZKI 3/4/96
 NAME: HEADER ASSEMBLY, MOD II, BREAKAWAY, DOUBLE ROW, .100 X.100CL, VERTICAL, WITH RETENTION FEATURE, .025 SQ.POSTS, HIGH TEMPERATURE
 DRAWING NO: 00779
 DRAWING NO: 146273
 STRENGTH OF CONNECTIVITY

X-ON Electronics

Largest Supplier of Electrical and Electronic Components

Click to view similar products for [Headers & Wire Housings](#) category:

Click to view products by [TE Connectivity](#) manufacturer:

Other Similar products are found below :

[892-18-020-10-001101](#) [58102-G61-06LF](#) [582553-1](#) [0009485154](#) [009176003701906](#) [0050291907](#) [LY20-4P-DT1-P1E-BR](#) [02.125.8002.8](#)
[609-3404](#) [61062-3](#) [61082-181009](#) [622-3653LF](#) [63453-116](#) [636-1030](#) [636-1427](#) [636-3427](#) [636-4007](#) [641938-9](#) [641991-4](#) [644827-2](#) [65817-](#)
[010LF](#) [65817-015LF](#) [65863-015LF](#) [66207-023LF](#) [67095-007LF](#) [67601157](#) [68645-018](#) [68648-049](#) [70.362.1628.0](#) [70-4210](#) [70-4226B](#) [70-](#)
[4853B](#) [707-5020](#) [707-5028](#) [71.350.2428.0](#) [71918-208LF](#) [71961-016LF](#) [733-134](#) [733-162](#) [754199-000](#) [760-3052](#) [787-8014-00](#) [79531-3000](#)
[FCN-360C032-B](#) [FCN-367T-T012/H](#) [FCN-723D010/2](#) [80.063.4001.1](#) [800-90-001-10-001000](#) [800-90-010-10-002000](#) [801-43-002-10-013000](#)