

THIS DRAWING IS UNPUBLISHED. RELEASED FOR PUBLICATION JUNE , 2004.
 © COPYRIGHT 2004 By - ALL RIGHTS RESERVED.

LOC	DIST	REVISIONS					
E	B	P	LTR	DESCRIPTION	DATE	DWN	APVD
		C1		ECO-09-023525	20 OCT 09	RITA	BOB
		D		ECO-12-014680	20Aug2012	TITAN	MARTIN

- NOTES**
- 1 IP PACK: 1PC/ONE BAG, 100PCS/INNER BOX, 1000PCS/OUTER BOX
 - 2 BULK PACK: 100PCS/ONE BAG, 100PCS/INNER BOX, 1000PCS/OUTER BOX
 - 3 Au PLATING OVER Ni PLATING OVER Cu PLATING
 - 4 Ni PLATING OVER Cu PLATING
 5. HAND TOOL: 9-1478240-0
 6. DIE SET: SEE TABLE
 7. FOR TECHNICAL DATA REFER TO YOUR LOCAL TYCO ELECTRONICS SALES OFFICE
 8. ALL DIMENSIONS ARE NOMINAL FOR REFERENCE ONLY UNLESS OTHERWISE STATED

			1.1	9-1478242-0	RG58C/U, 141A/U, URM43, 76, BELDEN 9907, KX 15		5-1634511-3
			1.1	9-1478242-0	RG58C/U, 141A/U, URM43, 76, BELDEN 9907, KX 15		5-1634511-2
			0.57	9-1478242-0	RG174A/U, 188A/U, 316/U, URM95, KX 3B, KX 22A		5-1634511-1
			0.57	9-1478242-0	RG174A/U, 188A/U, 316/U, URM95, KX 3B, KX 22A		5-1634511-0
			A	DIE SET	CABLE GROUPS		PART NO.
DIMENSIONS							

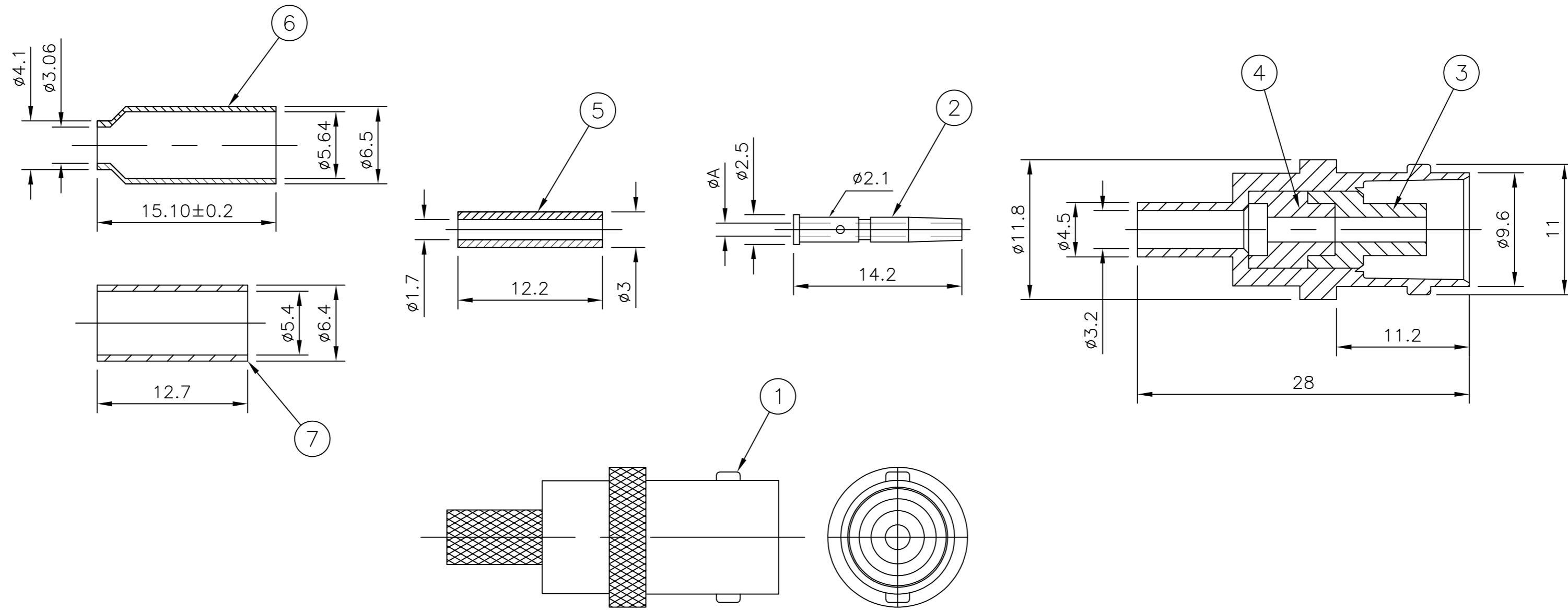

QTY	UNIT	DESCRIPTION	ITEM
1	1	BRASS	CRIMP SLEEVE 7
-	-	BRASS	CRIMP SLEEVE 6
-	-	NYLON	PUSHER SLEEVE 5
1	1	POLYMETHYLPENTENE	INSULATOR 4
1	1	POLYMETHYLPENTENE	INSULATOR 3
1	1	PHOSPHOR BRONZE	CONTACT 2
1	1	ZINC ALLOY	BODY 1
5	35	25	15

Obsolete

THIS DRAWING IS A CONTROLLED DOCUMENT.

DWN	RITA ZUO	24 Feb 09
CHK	ANSON MA	24 Feb 09
APVD	BOB ZHAO	24 Feb 09
PRODUCT SPEC	108-112000	
APPLICATION SPEC	SEE SHEET 2	
MATERIAL	SEE TABLE	
FINISH	SEE TABLE	

TE Connectivity

BNC STRAIGHT JACK CRIMP
50 OHM

SIZE	CAGE CODE	DRAWING NO	RESTRICTED TO
A2	00779	C=1634511	-
SCALE	NTS	SHEET	1 OF 2
REV	D		

THIS DRAWING IS UNPUBLISHED. RELEASED FOR PUBLICATION JUNE ,2004.
 © COPYRIGHT 2004 By - ALL RIGHTS RESERVED.

LOC	DIST	REVISIONS			
P	LTR	DESCRIPTION	DATE	DWN	APVD
-	-	SEE SHEET 1	-	-	-

COMPONENTS

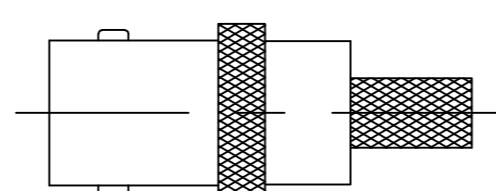
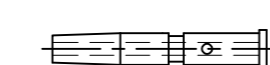
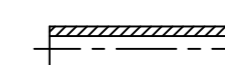
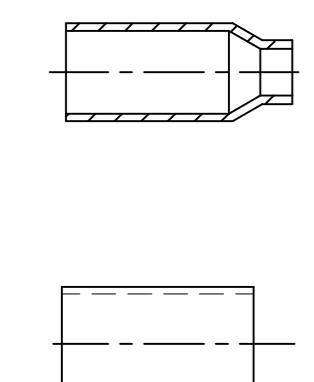
MAIN BODY (ITEM 1,3, & 4)	CONTACT (ITEM 2)	PUSHER SLEEVE (ITEM 5)	CRIMP FERRULES (ITEM 6 & 7)
			

ASSEMBLY INSTRUCTION

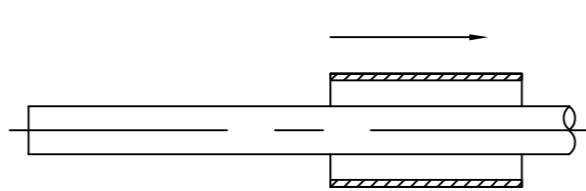
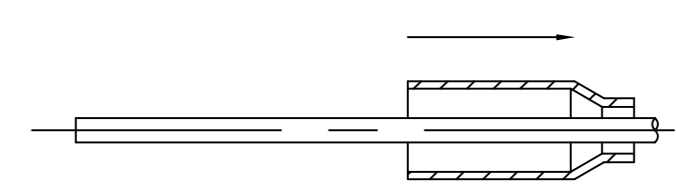
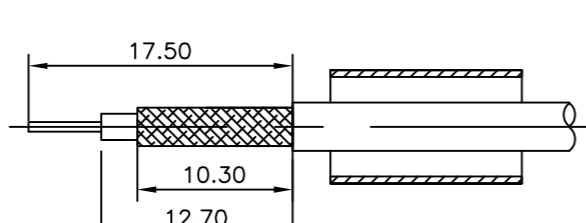
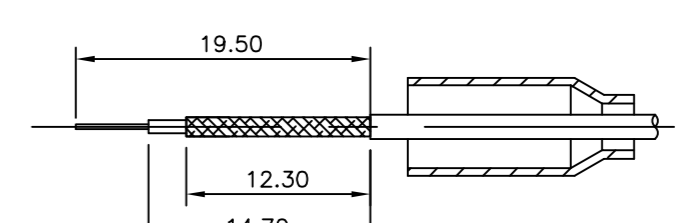
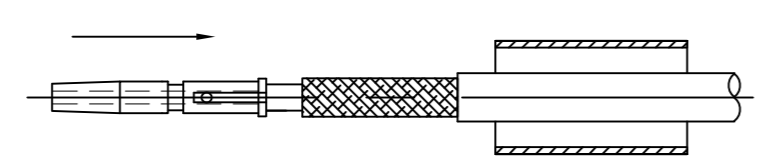
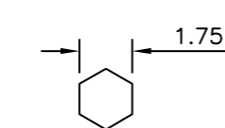
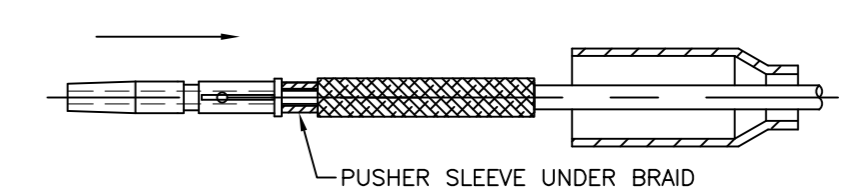
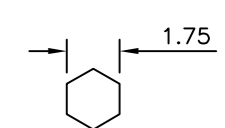
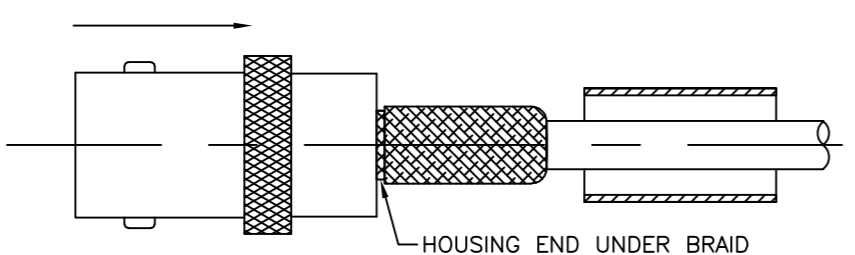
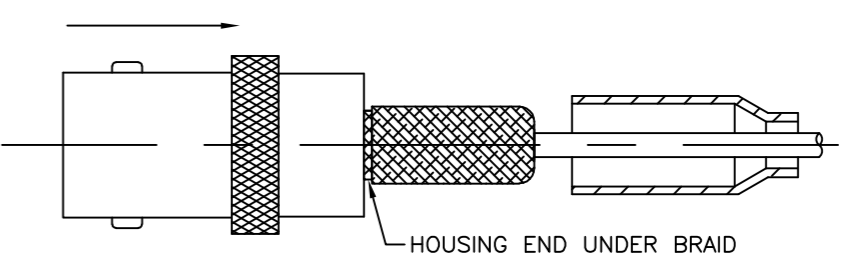
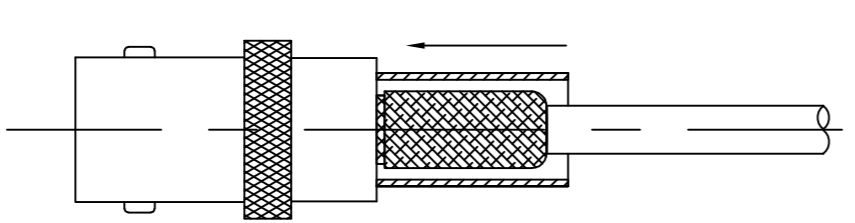
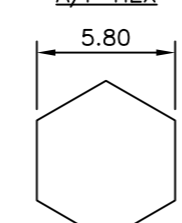
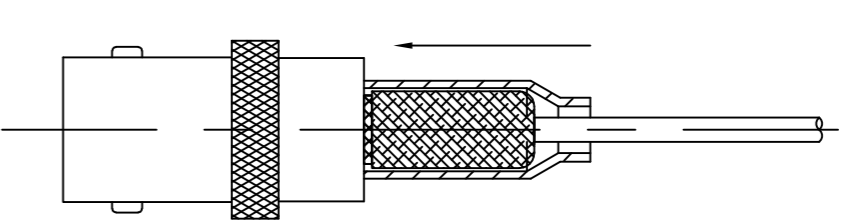
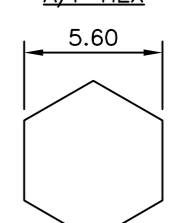
CABLES: RG58C/U, 141A/U, URM43, 76, BELDEN 9907, KX 15	CABLES: RG174A/U, 188A/U, 316/U, URM95, KX 3B, KX 22A
<p>STEP 1</p> <p>1. SLIDE METAL CRIMP FERRULE OVER CABLE</p> 	<p>STEP 1</p> <p>1. SLIDE METAL CRIMP FERRULE OVER CABLE</p> 
<p>STEP 2</p> <p>1. STRIP CABLE TO DIMENSIONS AS SHOWN</p> 	<p>STEP 2</p> <p>1. STRIP CABLE TO DIMENSIONS AS SHOWN</p> 
<p>STEP 3</p> <p>1. FIT CONTACT OVER CENTRE CONDUCTOR TO BUTT AGAINST DIELECTRIC. 2. CRIMP USING TOOL AS NOTES ON PAGE 1.</p>  <p>RECOMMENDED CENTRE CONTACT A/F HEX</p> 	<p>STEP 3</p> <p>1. SLIDE ITEM 10 PUSHER SLEEVE OVER DIELECTRIC BEFORE FITTING THE CONTACT. 2. FIT CONTACT OVER CENTRE CONDUCTOR TO BUTT AGAINST DIELECTRIC. 3. CRIMP USING TOOL AS NOTES ON PAGE 1.</p>  <p>PUSHER SLEEVE UNDER BRAID</p> <p>RECOMMENDED CENTRE CONTACT A/F HEX</p> 
<p>STEP 4</p> <p>1. PRESS SUB-ASSEMBLY INTO BODY, UNTIL CONTACT IS FULLY LOCATED BY AN AUDIBLE CLICK. 2. ENSURE THAT KNURLED HOUSING INSERTS BETWEEN THE DIELECTRIC AND CABLE BRAID.</p>  <p>HOUSING END UNDER BRAID</p>	<p>STEP 4</p> <p>1. PRESS SUB-ASSEMBLY INTO BODY, UNTIL CONTACT IS FULLY LOCATED BY AN AUDIBLE CLICK. 2. ENSURE THAT KNURLED HOUSING INSERTS BETWEEN THE PUSHER SLEEVE AND CABLE BRAID.</p>  <p>HOUSING END UNDER BRAID</p>
<p>STEP 5</p> <p>1. SLIDE CRIMP FERRULE ALONG THE CABLE UNTIL IT BUTTS AGAINST THE HOUSING BODY. 2. CRIMP USING TOOL AS NOTED ON PAGE 1. 3. CRIMP DIMENSION AS SHOWN.</p>  <p>RECOMMENDED CRIMP SLEEVE A/F HEX</p> 	<p>STEP 5</p> <p>1. SLIDE CRIMP FERRULE ALONG THE CABLE UNTIL IT BUTTS AGAINST THE BODY HOUSING. 2. CRIMP USING TOOL AS NOTED ON PAGE 1. 3. CRIMP DIMENSION AS SHOWN.</p>  <p>RECOMMENDED CRIMP SLEEVE A/F HEX</p> 

THIS DRAWING IS A CONTROLLED DOCUMENT.

DWN	RITA ZUO	24 Feb 09
CHK	ANSON MA	24 Feb 09
APVD	BOB ZHAO	24 Feb 09

PRODUCT SPEC: 108-112000
 APPLICATION SPEC: SHEET 2

TE Connectivity
 BNC STRAIGHT JACK CRIMP
 50 OHM

SIZE: A2 CAGE CODE: 00779 DRAWING NO: C-1634511 RESTRICTED TO: -

SCALE: NTS SHEET: 2 of 2 REV: D

X-ON Electronics

Largest Supplier of Electrical and Electronic Components

Click to view similar products for [RF Connectors / Coaxial Connectors](#) *category:*

Click to view products by [TE Connectivity](#) *manufacturer:*

Other Similar products are found below :

[R125315120](#) [8915-1511-000](#) [89674-0827](#) [5916-1103-603](#) [6-0001-3](#) [6001-7071-019](#) [6002-7051-003](#) [6002-7551-202](#) [6059674-1](#) [619550-1](#)
[630059-000](#) [M39012/25-0021](#) [M39012/79-3008](#) [M39030/3-01N](#) [M39030/3-03N](#) [M3933/25-36N](#) [6500-7071-046](#) [M83723/72W24576](#)
[M83723/72W2457N](#) [6769](#) [CX050L2AQ](#) [7002-1541-010](#) [7002-1572-002](#) [7003-1572-002](#) [7010-1511-000](#) [7029-1511-060](#) [7101-1541-010](#)
[7101-1571-002](#) [7105-1521-002](#) [7145-1521-002](#) [7209-1511-011](#) [7210-1511-015](#) [7210-1511-019](#) [7225-1512-050](#) [7242-1511-000](#) [73137-5015](#)
[73251-0111](#) [73251-0672](#) [7325-1512-000](#) [73276-1501](#) [73366-0013](#) [73404-2300](#) [73413-6080](#) [73415-5721](#) [7405-1521-005](#) [7405-1521-802](#)
[7406-1521-005](#) [804S01D04M040](#) [8145-1521-002](#) [81590](#)