

REVISIONS					
P	LTR	DESCRIPTION	DATE	DWN	APVD
G1		ECR-19-013959	06SEP2019	A.L	H.L

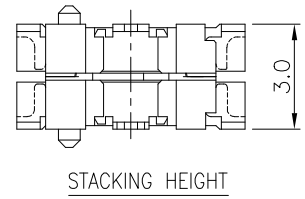
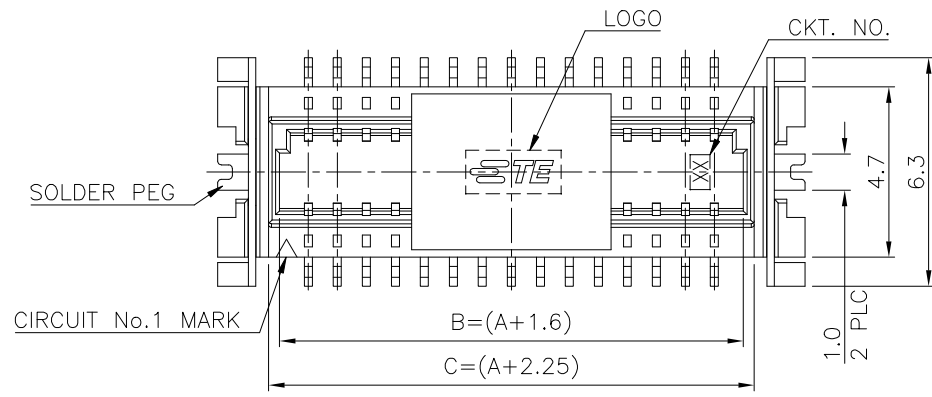

- NOTES:
- MATERIAL:
 - HOUSING: PA6T, UL94V-0; COLOR: NATURAL.
 - CONTACTS: PHOSPHOR BRONZE.
 - PEGS: BRASS.
 - FINISH:

CONTACTS: (SEE TABLE)
 PLATING B : GOLD FLASH ON ENTIRE CONTACT.
 PLATING C : 100μ" MIN. MATTE-TIN ON ENTIRE CONTACT.
 (WITH ENTIRE CONTACT UNDERPLATED 50μ" MIN. NICKEL.)
 PEGS: 100μ" MIN. TIN OR MATTE-TIN OVER 50μ" MIN. NICKEL.
 - PART NUMBER OF MATING RECEPTACLE: X-1775013-X
 - REFLOW SOLDER CAPABLE TO 260°C AS PER TEC-109-201, CONDITION B.
 - SUBSTANCE RESTRICTIONS FOR LOW HALOGEN (BY WEIGHT):

BROMINE (Br) ≤ 900 PPM (0.09%)
 CHLORINE (Cl) ≤ 900 PPM (0.09%)
 TOTAL CONCENTRATION OF (Cl) + (Br) ≤ 1500 PPM (0.15%)

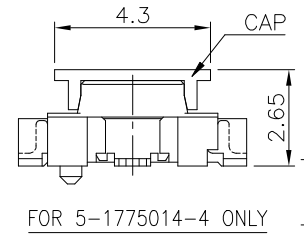
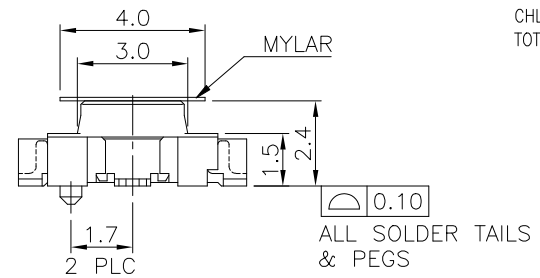
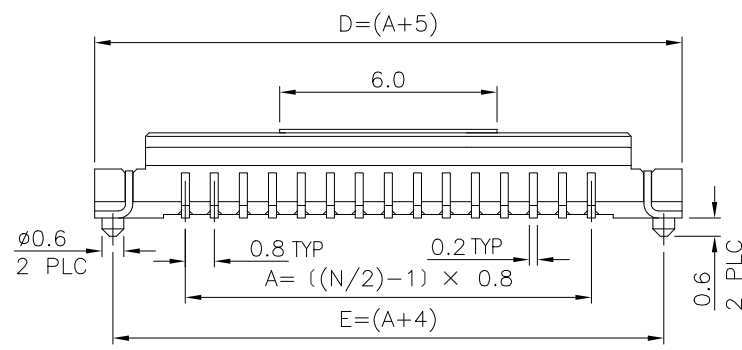

(1775014-1 & 5-1775014-4 ARE OBSOLETE)

CAP OR MYLAR	CONTACT PLATING	DIMENSIONS					NO. OF CONTACTS	PART NUMBER
		E	D	C	B	A		
CAP	C	8	9	6.25	5.6	4.0	12	5-1775014-4
MYLAR	B	12.8	13.8	11.05	10.4	8.8	24	1775014-2
		8	9	6.25	5.6	4.0	12	1775014-1

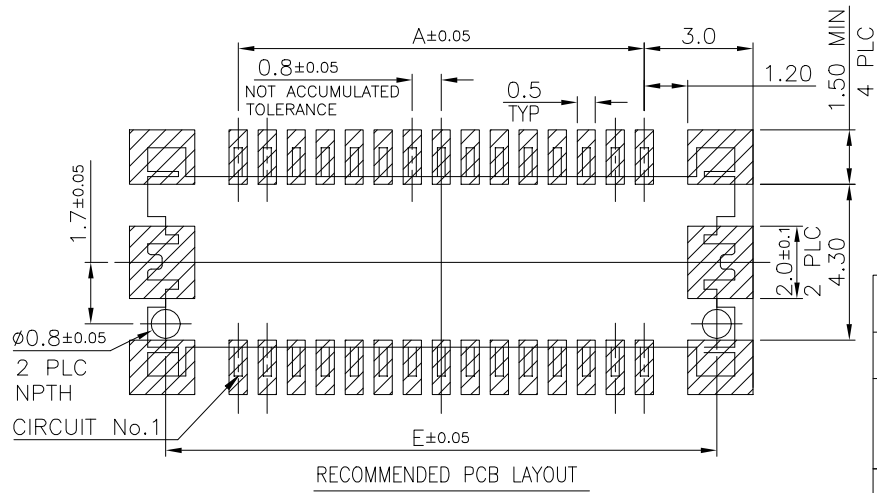

THIS DRAWING IS A CONTROLLED DOCUMENT.

DIMENSIONS: mm	TOLERANCES UNLESS OTHERWISE SPECIFIED:	DWN A. WU 05FEB2013	TE Connectivity BOARD-TO-BOARD CONNECTOR, 0.8mm PITCH, FINE-STACK 3H. PLUG
	0 PLC ± -	CHK S. CHIEN 05FEB2013	
	1 PLC ± 0.3	APVD W. KODAMA 05FEB2013	
	2 PLC ± 0.2	NAME	
MATERIAL	FINISH	PRODUCT SPEC 108-57488	SIZE CAGE CODE DRAWING NO RESTRICTED TO
		APPLICATION SPEC	A3 00779 C=1775014
		WEIGHT 0	SCALE 7:1 SHEET 1 OF 2 REV G1
		CUSTOMER DRAWING	

THIS DRAWING IS UNPUBLISHED.

RELEASED FOR PUBLICATION

ALL RIGHTS RESERVED.

© COPYRIGHT - By -

REVISIONS

P	LTR	DESCRIPTION	DATE	DWN	APVD
-	-	SEE SHEET 1	-	-	-

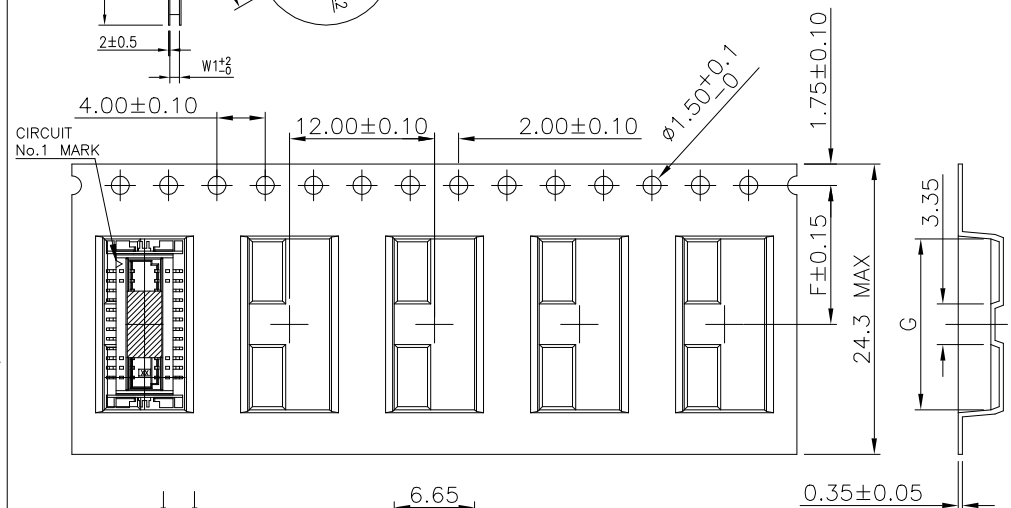
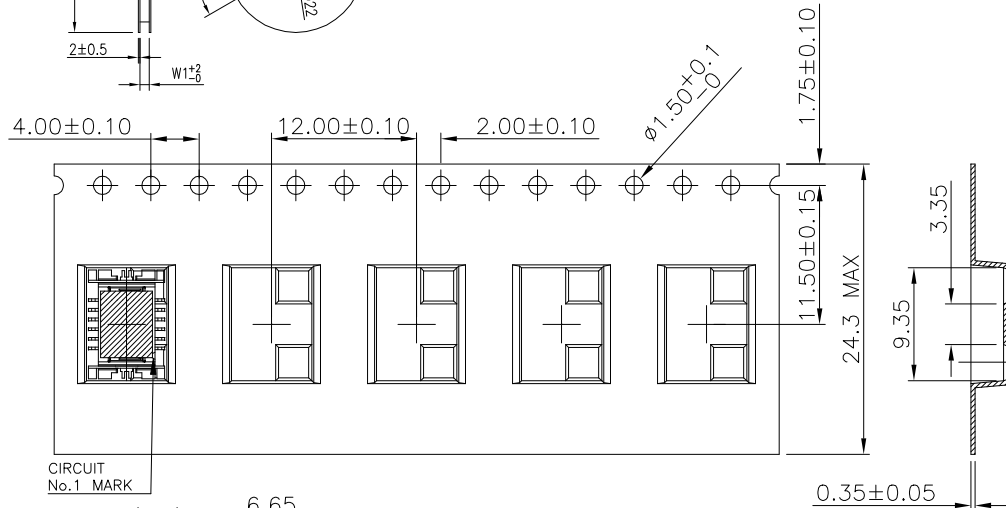
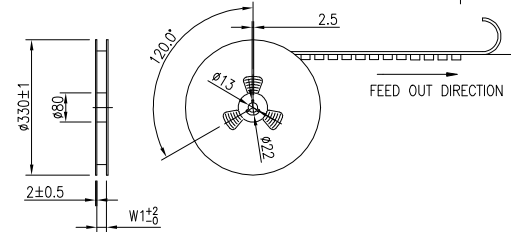
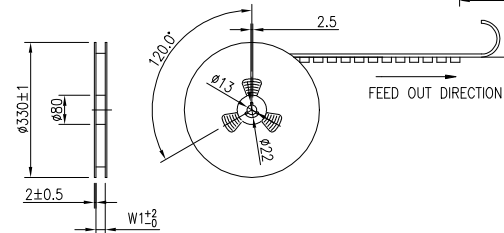
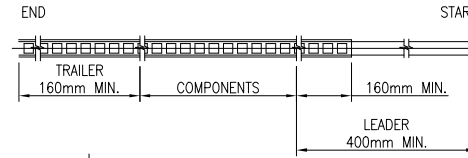
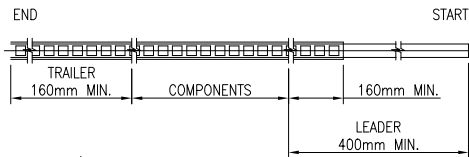

CIRCUIT No.1 MARK

CIRCUIT No.1 MARK

FOR 5-1775014-4 ONLY

FOR 12, 24 CONTACTS (WITH OR WITHOUT MYLAR)

NOTES:

- MATERIAL:
BOX: FIBREBOARD, CORRUGATED, DOUBLE WALL.
COVER TAPE: PET, TRANSPARENT COLOR.
CARRIER TAPE: POLYSTYRENES, BLACK COLOR.
REEL: PAPER, BROWN COLOR.
BAG: POLYETHYLENES, TRANSPARENT COLOR.
- EACH BAG SHALL BE INCLUDED DESICCANT.
- PEELING STRENGTH: 0.1~1.3 N (10~130 GRAMS).
- PEELING SPEED: 300 mm/min.

1500	24.40	24.00	14.15	11.50	24
1500	24.40	24.00	9.35	11.50	12
PCS / TAPE	W1	W	G	F	NO. OF CONTACTS
DIMENSIONS					

THIS DRAWING IS A CONTROLLED DOCUMENT.		DWN A. WU 05FEB2013	TE Connectivity		
DIMENSIONS: mm		CHK S. CHIEN 05FEB2013			
TOLERANCES UNLESS OTHERWISE SPECIFIED:		APVD W. KODAMA 05FEB2013	NAME BOARD-TO-BOARD CONNECTOR, 0.8mm PITCH, FINE-STACK 3H. PLUG		
0 PLC ± - 1 PLC ± 0.3 2 PLC ± 0.2 3 PLC ± 0.15 4 PLC ± - ANGLES ± 2°		PRODUCT SPEC 108-57488	SIZE A3		
MATERIAL		APPLICATION SPEC	CAGE CODE 00779	DRAWING NO G=1775014	RESTRICTED TO
-		WEIGHT 0	CUSTOMER DRAWING		SCALE 7:1 SHEET 2 OF 2 REV G1

X-ON Electronics

Largest Supplier of Electrical and Electronic Components

Click to view similar products for [Headers & Wire Housings](#) category:

Click to view products by [TE Connectivity](#) manufacturer:

Other Similar products are found below :

[892-18-020-10-001101](#) [58102-G61-06LF](#) [582553-1](#) [0009485154](#) [009176003701906](#) [0050291907](#) [LY20-4P-DT1-P1E-BR](#) [02.125.8002.8](#)
[609-3404](#) [61062-3](#) [61082-181009](#) [622-3653LF](#) [63453-116](#) [636-1030](#) [636-1427](#) [636-3427](#) [636-4007](#) [641938-9](#) [641991-4](#) [644827-2](#) [65817-](#)
[010LF](#) [65817-015LF](#) [65863-015LF](#) [66207-023LF](#) [67095-007LF](#) [67601157](#) [68645-018](#) [68648-049](#) [70.362.1628.0](#) [70-4210](#) [70-4226B](#) [70-](#)
[4853B](#) [707-5020](#) [707-5028](#) [71.350.2428.0](#) [71918-208LF](#) [71961-016LF](#) [733-134](#) [733-162](#) [754199-000](#) [760-3052](#) [79531-3000](#) [FCN-](#)
[360C032-B](#) [FCN-367T-T012/H](#) [FCN-723D010/2](#) [80.063.4001.1](#) [800-90-001-10-001000](#) [800-90-010-10-002000](#) [801-43-002-10-013000](#)
[801-43-006-10-002000](#)