

THIS DRAWING IS UNPUBLISHED. RELEASED FOR PUBLICATION NOV ,2006.

© COPYRIGHT 2006 BY TYCO ELECTRONICS CORPORATION. ALL RIGHTS RESERVED.

LOC	DIST	REVISIONS					
E	B	P	LTR	DESCRIPTION	DATE	DWN	APVD
		C		REVISED PER ECO-09-003420	19FEB09	ANS	BOB

NOTES

- 1 SINGLE PACK IN ACCORDANCE WITH AMP SPEC 107-3275
- 2 100 PER BOX ACCORDANCE WITH AMP SPEC 107-3275
- 3 NICKEL PLATING
- 4 GOLD PLATING
- 5. FOR TECHNICAL DATA REFER TO YOUR LOCAL TYCO ELECTRONICS SALES OFFICE
- 6. ALL DIMENSIONS ARE NOMINAL FOR REFERENCE ONLY UNLESS OTHERWISE STATED

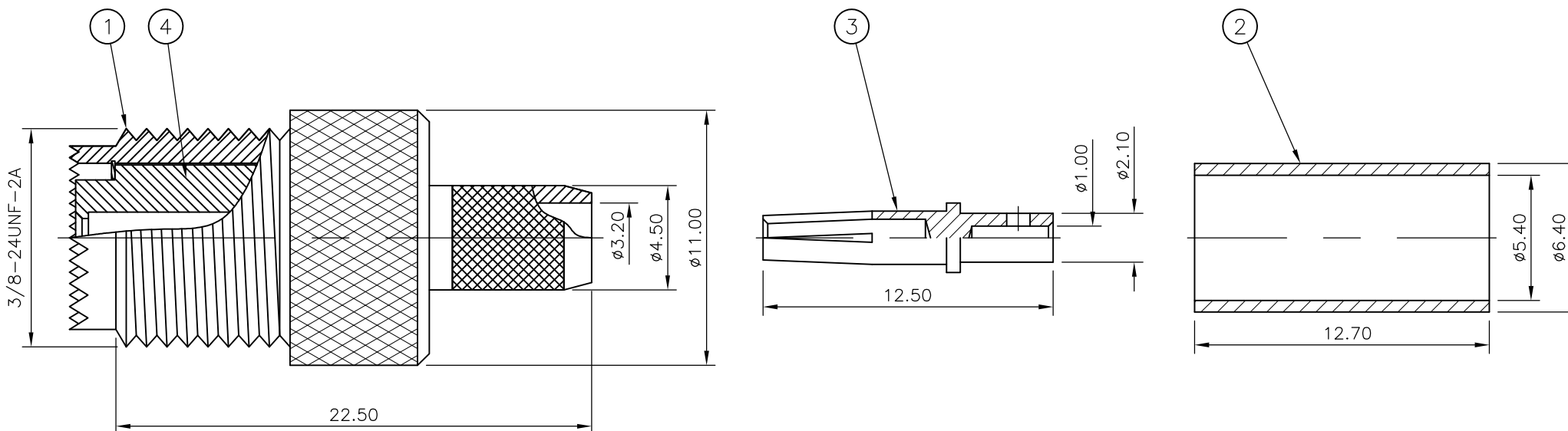

					1	1	POM	INSULATOR	4
					1	1	BRASS	CONTACT	3
					1	1	ZINC ALLOY	FERRULE	2
					1	1	BRASS	BODY	1
					5	15	MATERIAL	DESCRIPTION	ITEM
QUANTITY PER ASSY							PARTS LIST		

THIS DRAWING IS A CONTROLLED DOCUMENT.		DWN	ANSON MA	14FEB09	Tyco Electronics Corporation Kunshan, Jiangsu, PRC 215312				
DIMENSIONS: mm		CHK	RITA ZUO	14FEB09					
TOLERANCES UNLESS OTHERWISE SPECIFIED:		APVD	BOB ZHAO	14FEB09	NAME				
0 PLC ± -		PRODUCT SPEC			M-UHF STR JK HEX				
1 PLC ± 0.3		APPLICATION SPEC			RG58C/U, 141A/U, URM43, 76, KX15				
2 PLC ± 0.2		SEE SHEET 2			SIZE	CAGE CODE	DRAWING NO	RESTRICTED TO	
3 PLC ± -		MATERIAL			A3	00779	C-1814819	-	
4 PLC ± -		FINISH			CUSTOMER DRAWING				
ANGLES ± -		SEE TABLE			SCALE	SHEET	OF	REV	
± -					NTS	1	2	C	

THIS DRAWING IS UNPUBLISHED. RELEASED FOR PUBLICATION NOV. 2004.
 © COPYRIGHT 2006 BY TYCO ELECTRONICS CORPORATION. ALL RIGHTS RESERVED.

LOC	DIST	REVISIONS					
E	B	P	LTR	DESCRIPTION	DATE	DWN	APVD
			-	SEE SHEET 1	-	-	-

ASSEMBLY INSTRUCTION
 RG58C/U, 141A/U, URM43, 76, KX15

STEP 1
 1. SLIDE METAL CRIMP FERRULE OVER CABLE

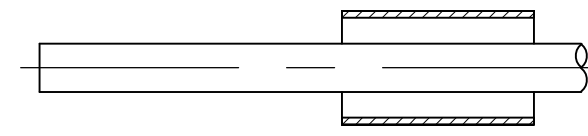

STEP 2
 1. STRIP CABLE TO DIMENSIONS AS SHOWN

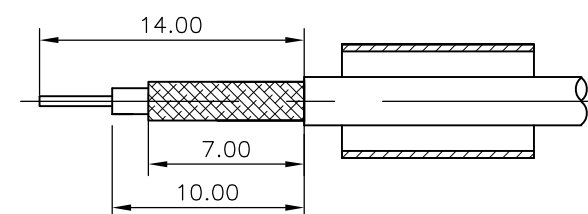

STEP 3
 1. FIT CONTACT OVER CENTRE CONDUCTOR TO BUTT AGAINST DIELECTRIC.
 2. CRIMP USING TOOL AS NOTES ON PAGE 1.

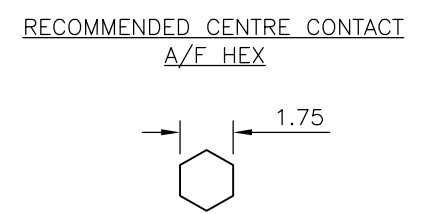
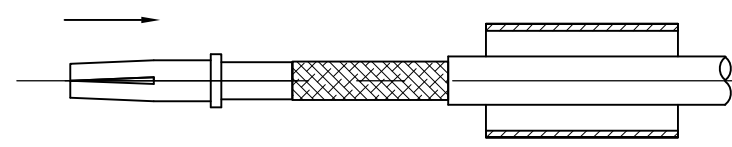

STEP 4
 1. PRESS SUB-ASSEMBLY INTO BODY, UNTIL CONTACT IS FULLY LOCATED BY AN AUDIBLE CLICK.
 2. ENSURE THAT KNURLED HOUSING INSERTS BETWEEN THE DIELECTRIC AND CABLE BRAID.

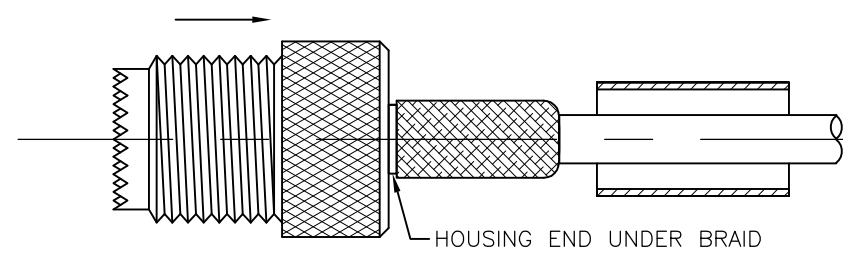

STEP 5
 1. SLIDE CRIMP FERRULE ALONG THE CABLE UNTIL IT BUTTS AGAINST THE HOUSING BODY.
 2. CRIMP USING TOOL AS NOTED ON PAGE 1.
 3. CRIMP DIMENSION AS SHOWN.

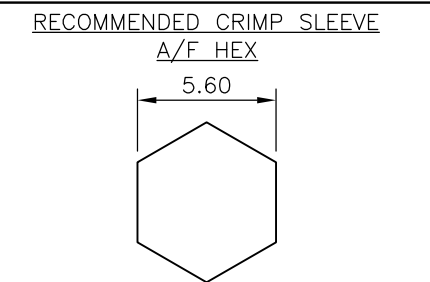
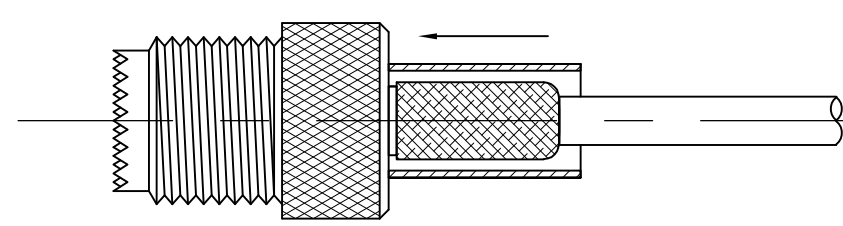

THIS DRAWING IS A CONTROLLED DOCUMENT.		DWN ANSON 14FEB09	Tyco Electronics Corporation Kunshan, Jiangsu, PRC 215312	
DIMENSIONS: mm		CHK RITA ZUO 14FEB09	NAME	
TOLERANCES UNLESS OTHERWISE SPECIFIED:		APVD BOB ZHAO 14FEB09	M-UHF STR JK HEX RG58C/U, 141A/U, URM43, 76, KX15	
0 PLC ± -		PRODUCT SPEC	-	
1 PLC ± -		108-112000	-	
2 PLC ± -		APPLICATION SPEC	-	
3 PLC ± -		SHEET 2	SIZE A3	CAGE CODE 00779
4 PLC ± -		WEIGHT -	DRAWING NO C-1814819	RESTRICTED TO -
ANGLES ± -		CUSTOMER DRAWING	SCALE NTS	SHEET 2 OF 2
FINISH ± -				REV C
MATERIAL SEE TABLE				

X-ON Electronics

Largest Supplier of Electrical and Electronic Components

Click to view similar products for [RF Connectors / Coaxial Connectors](#) category:

Click to view products by [TE Connectivity](#) manufacturer:

Other Similar products are found below :

[8915-1511-000](#) [89674-0827](#) [6001-7071-019](#) [6002-7051-003](#) [6002-7551-202](#) [6059674-1](#) [619550-1](#) [630059-000](#) [M39030/3-01N](#) [6500-7071-046](#) [6769](#) [CX050L2AQ](#) [7002-1541-010](#) [7002-1542-011](#) [7004-1512-000](#) [7009-1511-004](#) [7010-1511-000](#) [7029-1511-060](#) [7101-1541-010](#) [7101-1571-002](#) [7105-1521-002](#) [7145-1521-002](#) [7203-1571-003](#) [7209-1511-011](#) [7210-1511-015](#) [7210-1511-019](#) [73137-5015](#) [73216-2241](#) [73404-2300](#) [7405-1521-005](#) [7405-1521-802](#) [8527](#) [8547](#) [FS11V](#) [877931](#) [9049-9513-000](#) [9074-9513-000](#) [9101-9573-002](#) [910A205F](#) [9130-9573-002](#) [PL11SC-026](#) [PL375-33](#) [PL40-5](#) [PL74C-221](#) [PL75MC-217](#) [PL803-7](#) [1200690078](#) [1-201144-1](#) [R107003010W](#) [R110A172100](#)