

THIS DRAWING IS UNPUBLISHED. RELEASED FOR PUBLICATION  
 © COPYRIGHT - By - ALL RIGHTS RESERVED.

| LOC | DIST | REVISIONS |     |                           |         |     |      |
|-----|------|-----------|-----|---------------------------|---------|-----|------|
| G   | 14   | P         | LTR | DESCRIPTION               | DATE    | DWN | APVD |
|     |      | M1        |     | REVISED PER ECO-11-004917 | 11MAR11 | RK  | HMR  |

|                                |                                |                                |
|--------------------------------|--------------------------------|--------------------------------|
| <b>AMP</b><br>WIRE RANGE       | Listed<br>FILE E13288          | LR7189<br>Certified            |
| 22-16 AWG<br>SOLID OR STRANDED | 22-16 AWG<br>SOLID OR STRANDED | 22-16 AWG<br>SOLID OR STRANDED |

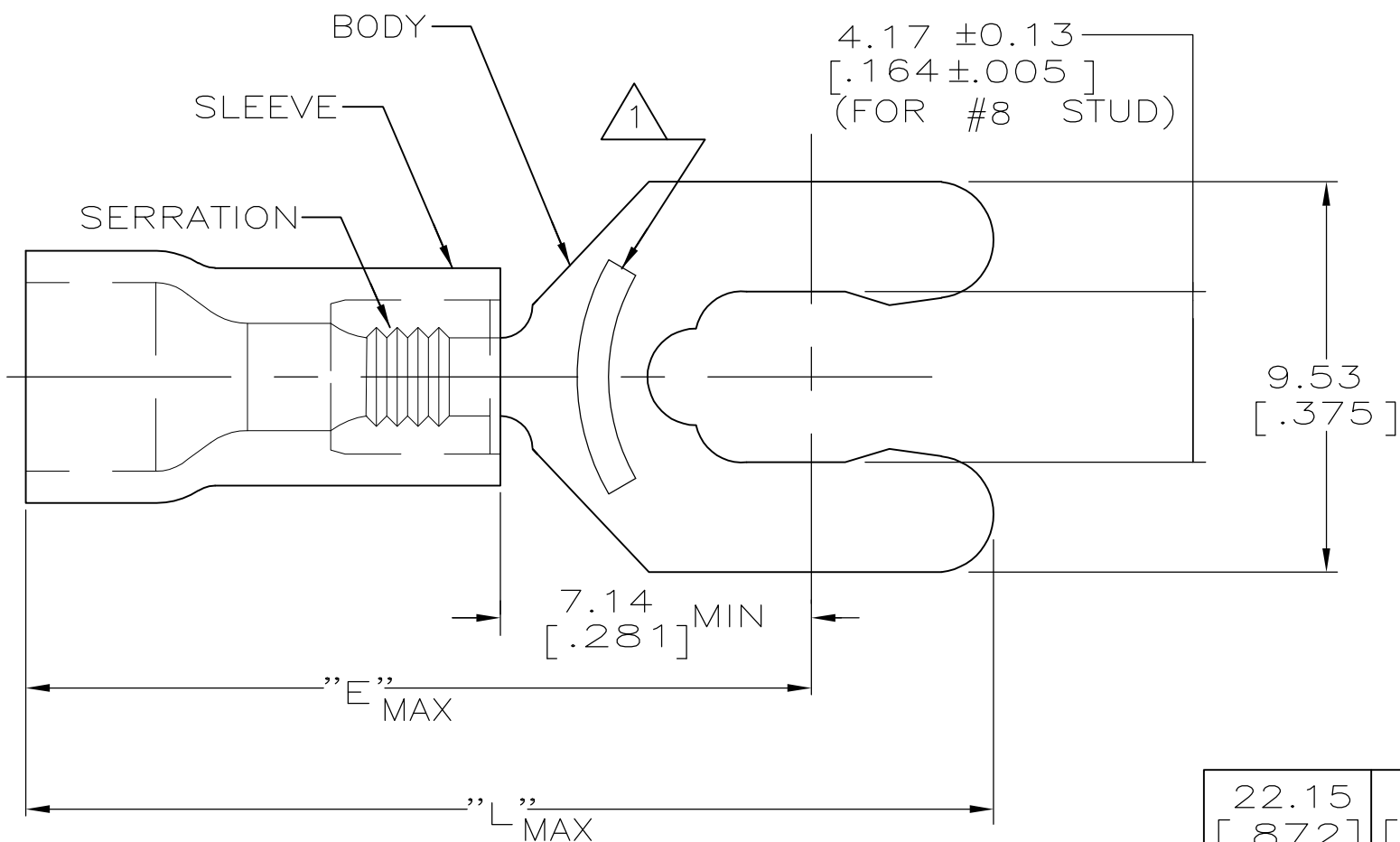

- 1 STAMP 8S AMP 22-18\* APPROX AS SHOWN  
22-16 TERMINALS ARE STAMPED 22-18 IN  
ACCORDANCE WITH MILITARY SPEC MIL-T-7928  
COMMERCIAL WIRE RANGE IS 22-16
- 2. SEE TABLE FOR WIRE INSUL DIA
- 3. TONGUE MATL THK, 0.79±0.05 [.031±.002]
- 4 MATERIAL: BODY - BRASS PER ASTM B36  
SLEEVE - PVC, COLOR - RED

|                 |                 |                          |      |                  |           |
|-----------------|-----------------|--------------------------|------|------------------|-----------|
| 22.15<br>[.872] | 17.70<br>[.697] | 2.67-3.56<br>[.105-.140] | 100  | LOOSE PIECE, BOX | 8-52950-1 |
| 23.39<br>[.921] | 18.95<br>[.746] | 3.81-5.08<br>[.150-.200] | 2500 | ON TAPE, REEL    | 52950-3   |
| 23.39<br>[.921] | 18.95<br>[.746] | 3.81-5.08<br>[.150-.200] | 1000 | LOOSE PIECE      | 52950-2   |
| 22.15<br>[.872] | 17.70<br>[.697] | 2.67-3.56<br>[.105-.140] | 5000 | ON TAPE, REEL    | 52950-1   |
| 22.15<br>[.872] | 17.70<br>[.697] | 2.67-3.56<br>[.105-.140] | 1000 | LOOSE PIECE      | 52950     |
| L               | E               | WIRE INSUL DIA           | QTY  | PACKAGE TYPE     | PART NO   |

**AMP INCORPORATED  
CUSTOMER SERVICE SYSTEMS**

FOR ADDITIONAL PRODUCT INFORMATION OR COPIES OF DRAWINGS AND TECHNICAL DOCUMENTS: PRODUCT INFORMATION CENTER 1-800-522-6752

FOR APPLICATION TOOLING ASSISTANCE CENTER: TOOLING INFORMATION 1-800-722-1111

FOR ORDER ENTRY: 1-800-526-5142

MAX RECOMMENDED OPERATING TEMPERATURE: 105°C [221°F]

VOLTAGE RATING: 600V MAX (1000V FIXTURE OR SIGN)

CIRCULAR MIL AREA: 0.26-1.65mm² [509-3260] SOLID OR STRANDED

THIS DRAWING IS A CONTROLLED DOCUMENT FOR AMP INCORPORATED. IT IS SUBJECT TO CHANGE AND THE CONTROLLING ENGINEERING ORGANIZATION SHOULD BE CONTACTED FOR THE LATEST REVISION.

THIS DRAWING IS A CONTROLLED DOCUMENT.

DIMENSIONS: mm [INCHES]

TOLERANCES UNLESS OTHERWISE SPECIFIED:

|        |               |
|--------|---------------|
| 0 PLC  | ± -           |
| 1 PLC  | ± -           |
| 2 PLC  | ± 0.20 [.008] |
| 3 PLC  | ± -           |
| 4 PLC  | ± -           |
| ANGLES | ± -           |

MATERIAL: TIN PER ASTM B545

DWN L OLMEDA 26JUN95  
 CHK M ELLIS 26JUN95  
 APVD G NGO 26JUN95

**STE** TE Connectivity

NAME: TERMINAL, SPRING SPADE, SHORT, PLASTI-GRIP, WIRE SIZE: 22-16

PRODUCT SPEC: UL 486A

APPLICATION SPEC: -

WEIGHT: -

SIZE: A3 CAGE CODE: 00779 DRAWING NO: C-52950 RESTRICTED TO: -

CUSTOMER DRAWING SCALE: 6:1 SHEET: 1 OF 1 REV: M1

## X-ON Electronics

Largest Supplier of Electrical and Electronic Components

*Click to view similar products for [Terminals](#) category:*

*Click to view products by [TE Connectivity](#) manufacturer:*

Other Similar products are found below :

[00-054007-01074-6](#) [00-054007-70206-1](#) [00-054007-70210-8](#) [00-054007-70217-7](#) [00-054007-70226-9](#) [00-054007-70228-3](#) [00-054007-70248-1](#) [00-054007-70256-6](#) [00-054007-70301-3](#) [00-054007-70316-7](#) [00-054007-49560-4](#) [00-054007-70209-2](#) [00-054007-70225-2](#) [00-054007-70227-6](#) [00-054007-70231-3](#) [00-054007-70241-2](#) [00-054007-70242-9](#) [00-054007-70244-3](#) [00-054007-70246-7](#) [00-054007-70263-4](#) [00-054007-70288-7](#) [00-054007-70290-0](#) [00-054007-70300-6](#) [00-054007-70304-4](#) [01-2065-1-0216](#) [01-2900-1-04412](#) [00581P0075](#) [600TS-10](#) [60205-1](#) [604200-1](#) [605601-1](#) [60598-1-CUT-TAPE](#) [61314-6-C](#) [61810-3](#) [61-S](#) [61-SN](#) [626-0194](#) [62-NBM-A](#) [62-SN](#) [62-SP](#) [63-S](#) [640179-1](#) [M55155/059I03](#) [M55155/079C01](#) [M55155/099H02](#) [M55155/109H01](#) [M55155/109H02](#) [M55155/12XH05](#) [M55155/16XH02](#) [M55155/29-5S](#)