

| REVISIONS | | | | | |
|-----------|-----|---------------|-----------|-----|------|
| P | LTR | DESCRIPTION | DATE | DWN | APVD |
| C | | ECO-20-004897 | 24AUG2020 | SB | JB |

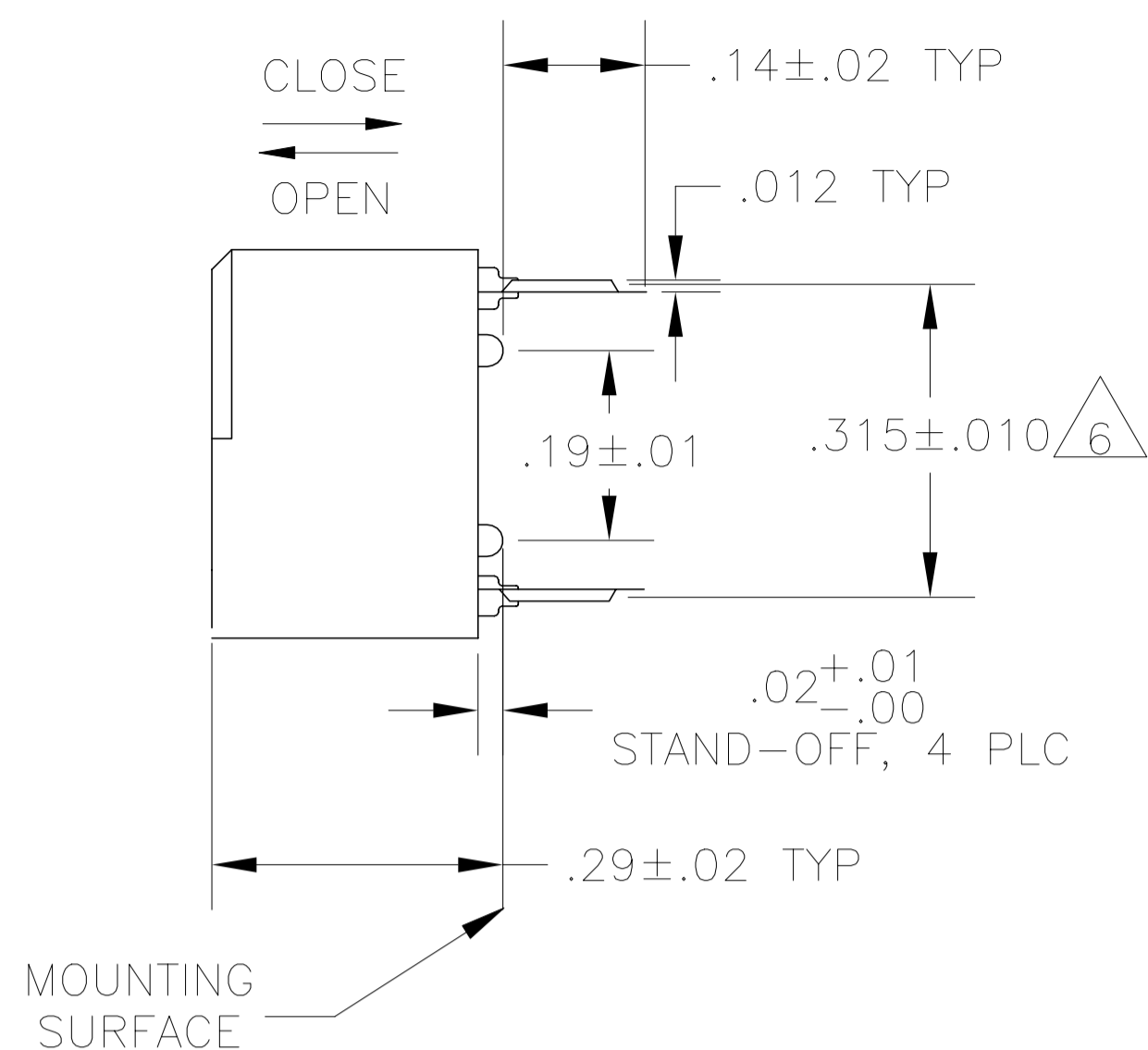
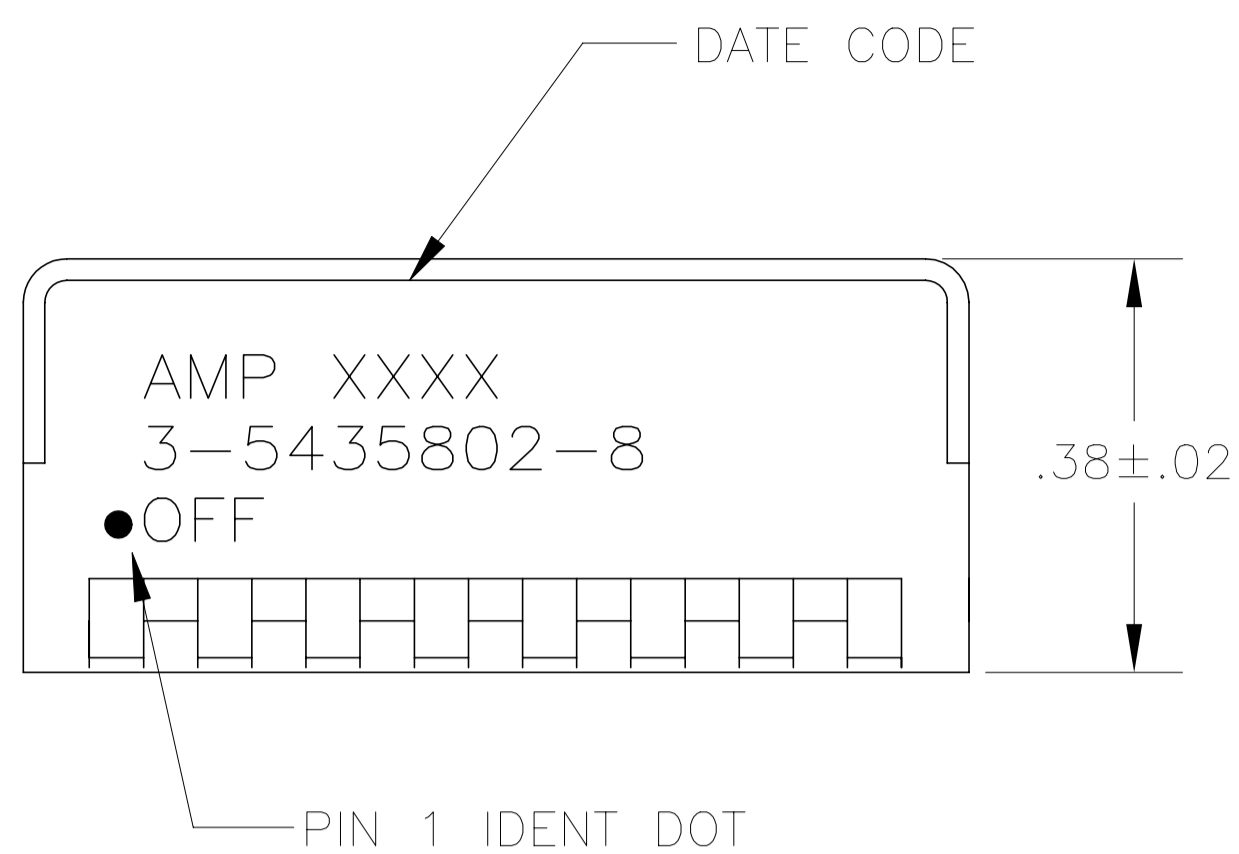

FIG 1

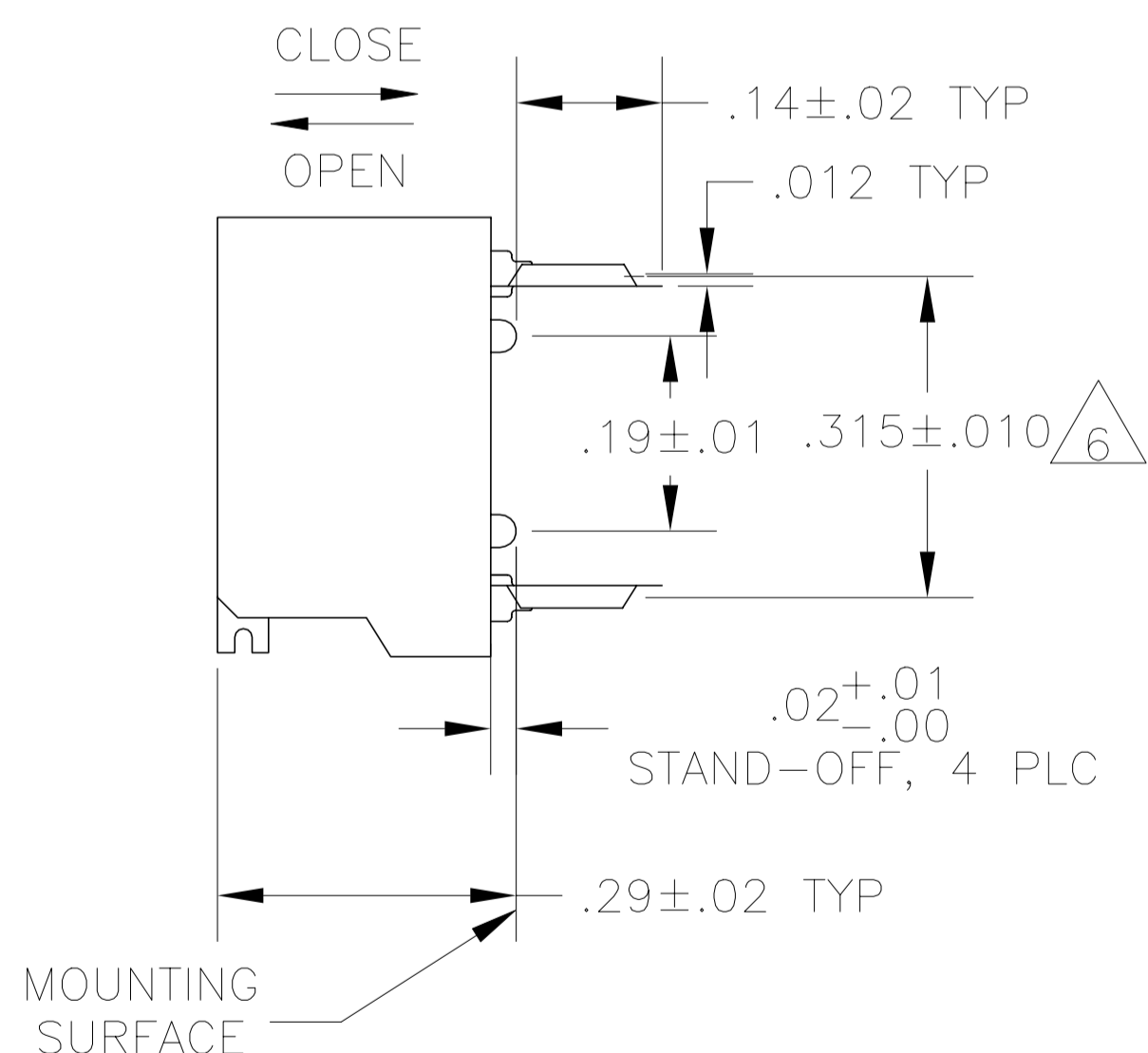
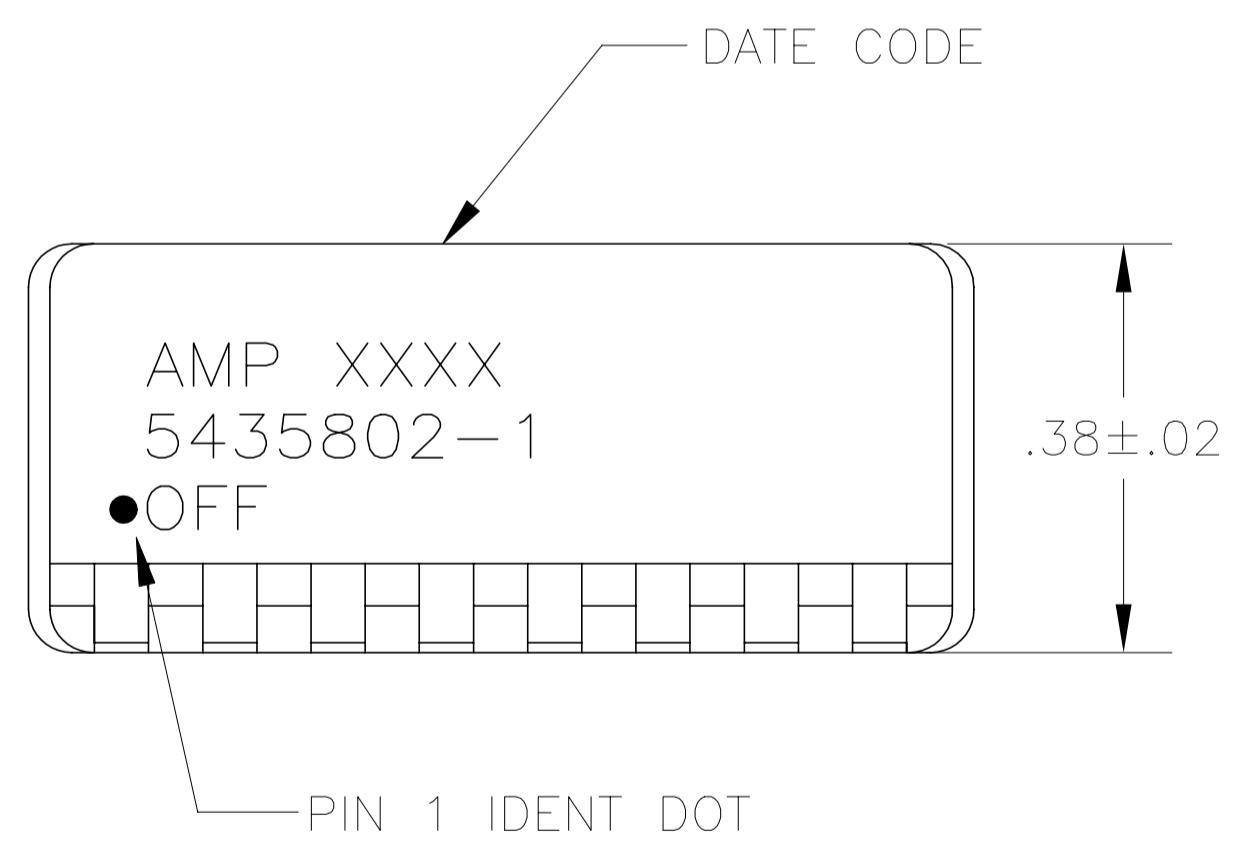
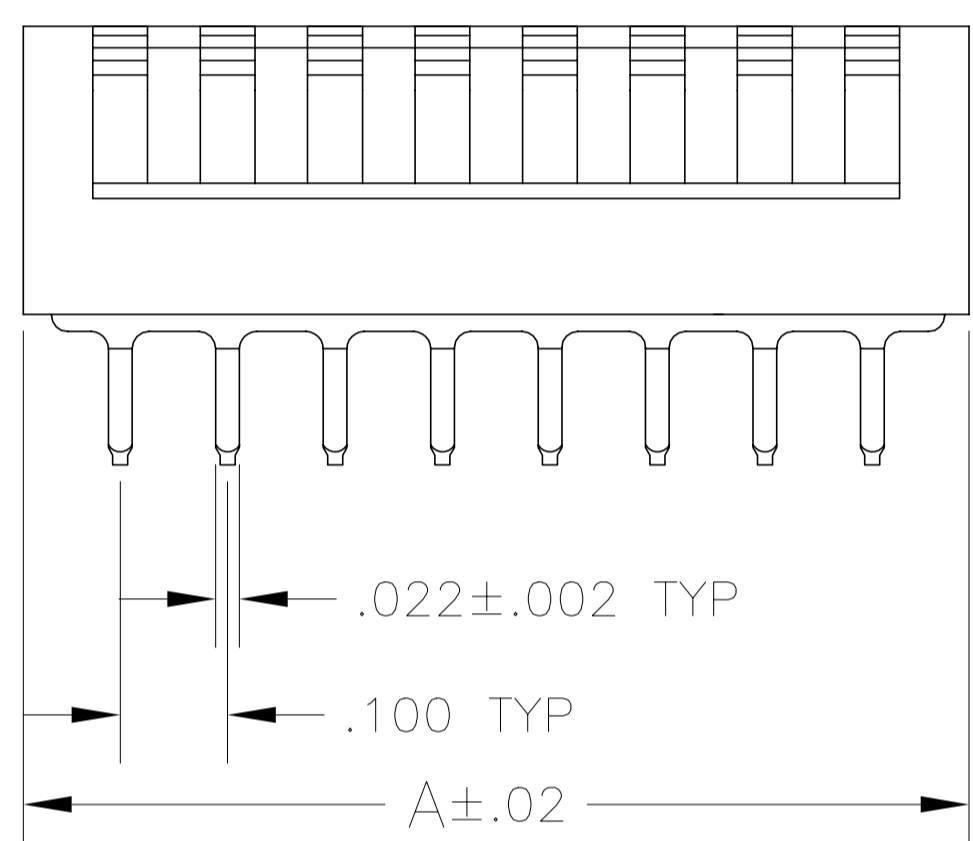
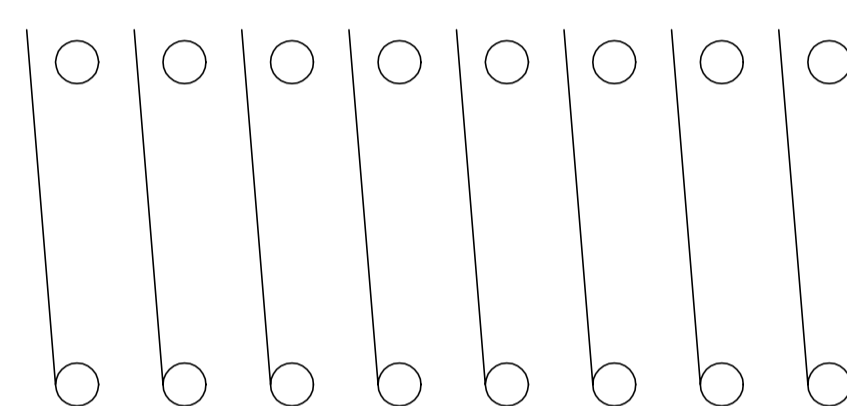
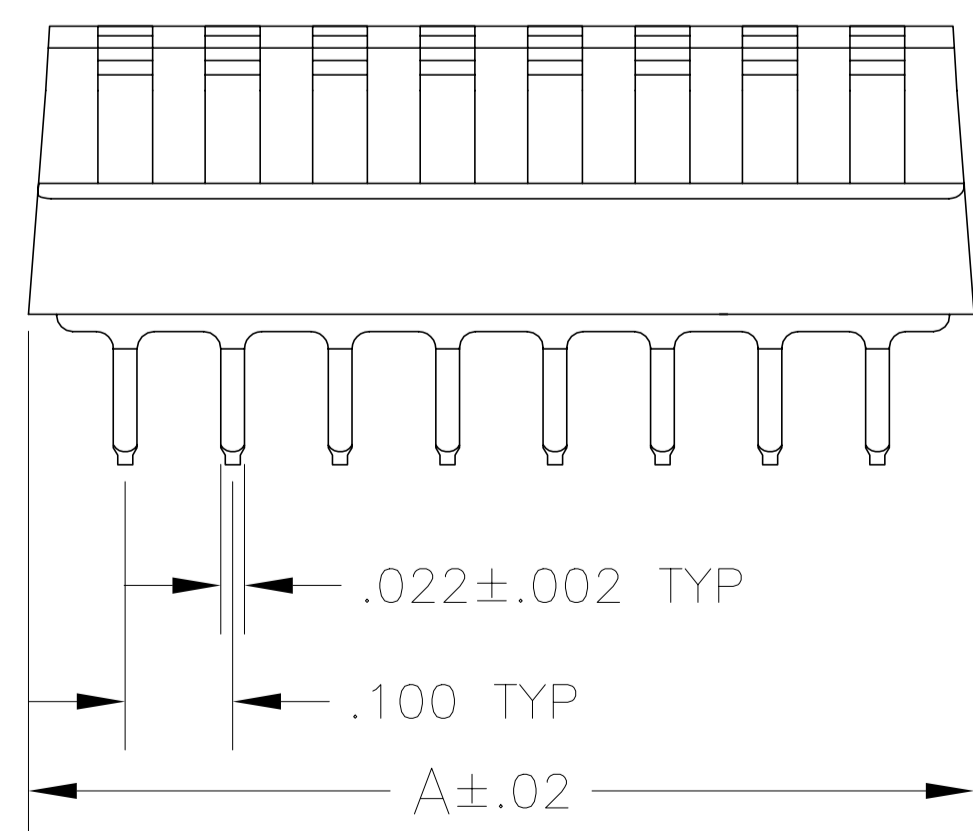

FIG 2



- FOR ADDITIONAL SPECIFICATIONS SEE AMP PRODUCT SPEC 108-7519.
- SWITCH SHOWN IN OPEN POSITION.
- ALL CHARACTERS AND ROCKERS ARE WHITE, HOUSING IS BLACK.
- LASER MARKING WILL VARY ON 2 AND 3 POSITION TOPS DUE TO SPACE RESTRICTIONS.
- $\triangle 5$ STRIPPABLE TRANSPARENT SEAL, SEE FIG 6.
- $\triangle 6$.315 DIMENSION APPLIES AT TERMINAL TIPS. TERMINALS ARE .300^{+.010}_{-.000} AT MOUNTING SURFACE.
- $\triangle 7$ NO POSITION MARKING.
- $\triangle 8$ NO PART NO. MARKING.
- $\triangle 9$ STRIPPABLE TAPE SEAL, SEE FIGURE 8.
- ALL MATERIALS AND FINISHES SHALL COMPLY WITH EU DIRECTIVE 2002/95/EC OF 27JAN2003 (ROHS)
- $\triangle 11$ MATERIAL: HOUSING AND ROCKERS - POLYESTER CONTACT & SOLDER LEAD - COPPER ALLOY
- $\triangle 12$ FINISH: CONTACT - GOLD OVER NICKEL SOLDER LEAD - TIN OVER NICKEL
- $\triangle 13$ OBSOLETE PARTS: OBSOLETE CIS STREAMLINING PER D.RENAUD/D.SINISI
- MARKS WILL BE ADDED BY LASER MARK PROCESS.

| | | | | | | |
|-------------------------|---------|-----------------------------|------------------|------|------------|-------------|
| | FIG 2 | FIG 3A& 7 | | 1.08 | 10 | 6-5435802-3 |
| | FIG 1 | FIG 3B | $\triangle 9$ | .88 | 8 | 3-5435802-8 |
| $\triangle 13$ OBSOLETE | FIG 2 | $\triangle 7$ $\triangle 8$ | $\triangle 5$ | .88 | 8 | 3-5435802-0 |
| | FIG 2 | $\triangle 7$ $\triangle 8$ | $\triangle 5$ | .48 | 4 | 2-5435802-9 |
| | FIG 2 | FIG 3A | $\triangle 5$ | 1.28 | 12 | 2-5435802-2 |
| | FIG 2 | | | 1.18 | 11 | 2-5435802-1 |
| | FIG 2 | | | 1.08 | 10 | 2-5435802-0 |
| | FIG 2 | | | .98 | 9 | 1-5435802-9 |
| | FIG 2 | | | .78 | 7 | 1-5435802-8 |
| | FIG 2 | | | .68 | 6 | 1-5435802-7 |
| | FIG 2 | | | .58 | 5 | 1-5435802-6 |
| | FIG 2 | $\triangle 8$ | | .48 | 4 | 1-5435802-5 |
| | FIG 2 | FIG 3A | | 1.28 | 12 | 1-5435802-2 |
| | FIG 1 | $\triangle 8$ | | .28 | 2 | 1-5435802-0 |
| | FIG 2 | FIG 3A | $\triangle 5$ | .88 | 8 | 5435802-9 |
| | FIG 2 | | | 1.08 | 10 | 5435802-8 |
| | FIG 2 | | | .98 | 9 | 5435802-7 |
| $\triangle 13$ OBSOLETE | FIG 2 | | | .78 | 7 | 5435802-6 |
| | FIG 2 | | | .68 | 6 | 5435802-5 |
| | FIG 2 | | | .58 | 5 | 5435802-4 |
| | FIG 2 | | | .48 | 4 | 5435802-3 |
| | FIG 2 | $\triangle 8$ | | .38 | 3 | 5435802-2 |
| 5435802-1 SHOWN | FIG 2 | FIG 3A | | .88 | 8 | 5435802-1 |
| | HOUSING | MARKING | PROT-ECTIVE SEAL | A | NO OF POSN | PART NO |

| | | | | | | | |
|--|--------------------------|--|---|--------------------|-------------------------|--------------------|----------|
| THIS DRAWING IS A CONTROLLED DOCUMENT. | | DWN R. TALLEY 19-9-89 | TE Connectivity Ltd. | | | | |
| DIMENSIONS: INCHES | | CHK R. MILLER 19-9-89 | | | | | |
| TOLERANCES UNLESS OTHERWISE SPECIFIED: | | APVD H. LEITER 19-9-89 | NAME SWITCH ASSY, DIP, TYPE C, 7000 SERIES, SPST, SIDE ACTUATED | | | | |
| 0 PLC ± - 1 PLC ± - 2 PLC ± - 3 PLC ± .005 4 PLC ± - ANGLES ± - | | PRODUCT SPEC - APPLICATION SPEC - | SIZE A2 | CAGE CODE 00779 | DRAWING NO C=5435802 | RESTRICTED TO - | |
| MATERIAL $\triangle 11$ | FINISH $\triangle 12$ | WEIGHT - | CUSTOMER DRAWING | | SCALE 4:1 | SHEET 1 of 2 | REV C |

| REVISIONS | | | | | |
|-----------|-----|-------------|------|-----|------|
| P | LTR | DESCRIPTION | DATE | DWN | APVD |
| - | - | SEE SHEET 1 | - | - | - |

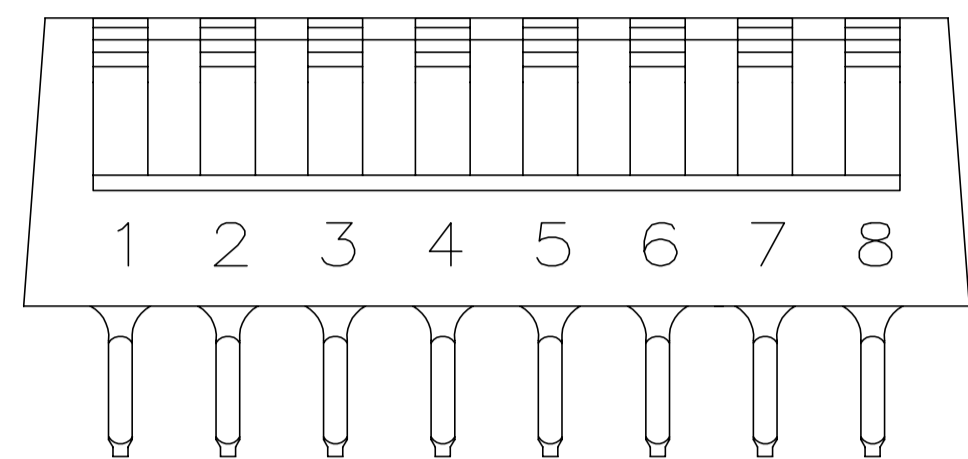

FIG 3A

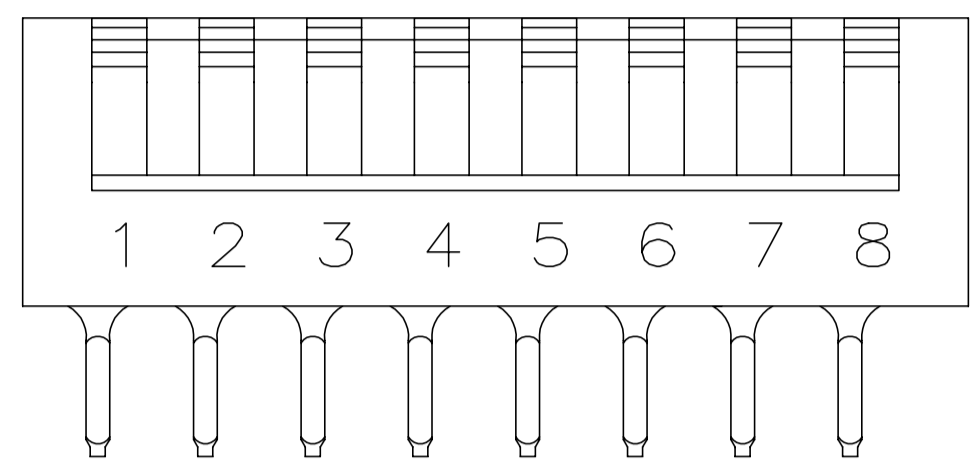

FIG 3B

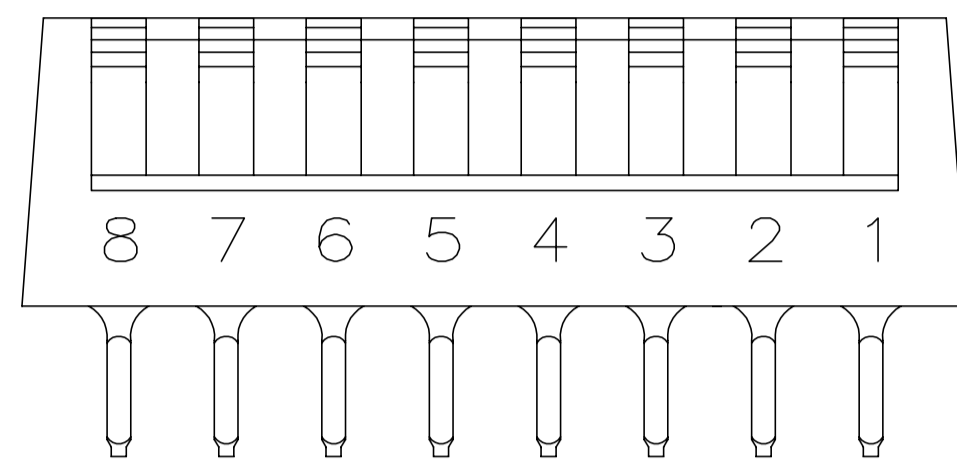
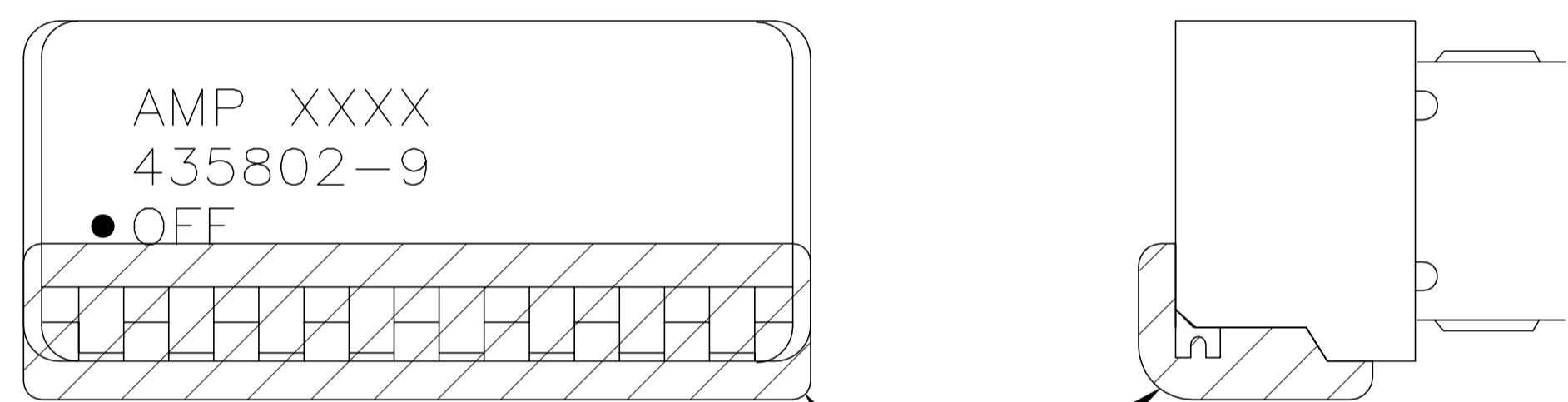
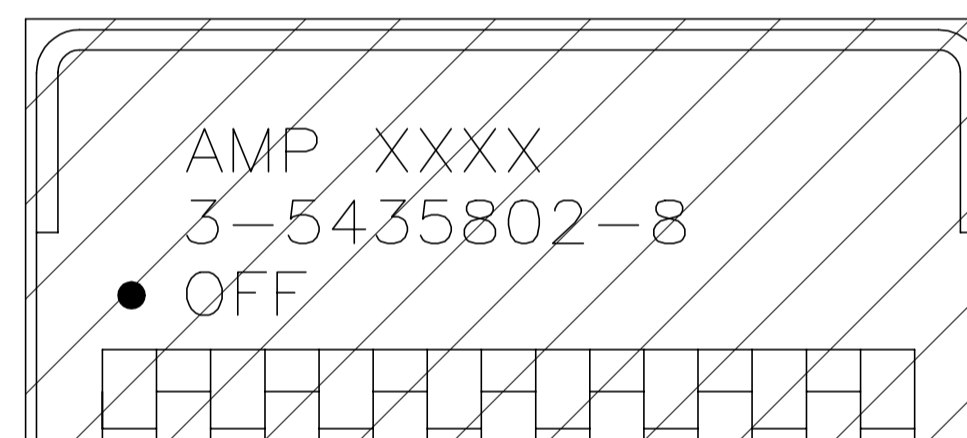

FIG 4



PROTECTIVE SEAL

FIG 6



PROTECTIVE SEAL

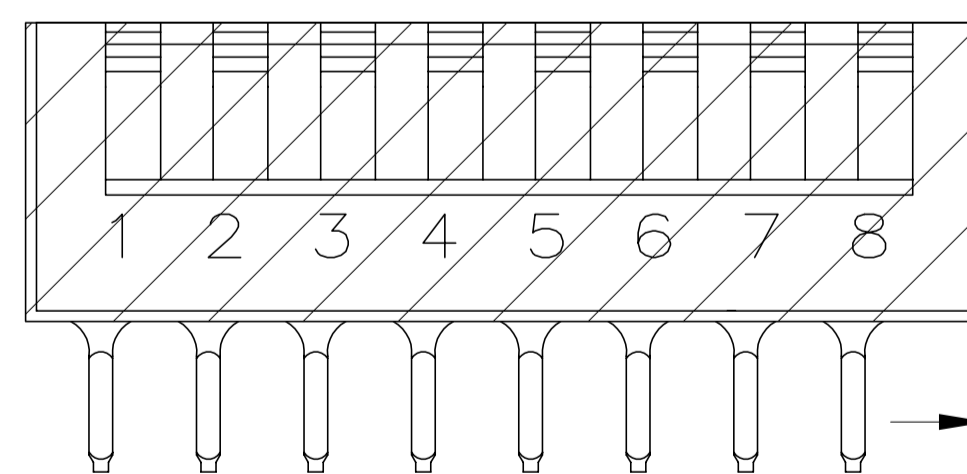

FIG 8

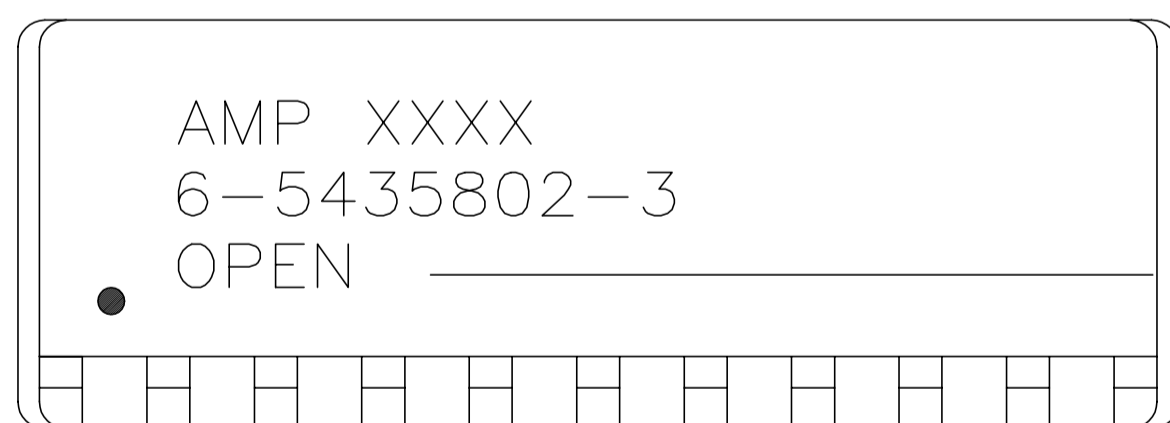

FIG 7

| | | | | | | | | | | | | | | | | |
|---|-----------------------|------------------------------|----------------------|--------------------|-------------------------|---------------|-----|-------|--------|-------|-----|--------|-----|--------------|---|--|
| THIS DRAWING IS A CONTROLLED DOCUMENT. | | DWN R. TALLEY 19-9-89 | TE Connectivity Ltd. | | | | | | | | | | | | | |
| DIMENSIONS: INCHES | | CHK R. MILLER 19-9-89 | | | | | | | | | | | | | | |
| TOLERANCES UNLESS OTHERWISE SPECIFIED: | | APVD H. LEITER 19-9-89 | NAME | | | | | | | | | | | | | |
| <table border="0"> <tr><td>0 PLC</td><td>± -</td></tr> <tr><td>1 PLC</td><td>± -</td></tr> <tr><td>2 PLC</td><td>± -</td></tr> <tr><td>3 PLC</td><td>± .005</td></tr> <tr><td>4 PLC</td><td>± -</td></tr> <tr><td>ANGLES</td><td>± -</td></tr> </table> | | 0 PLC | ± - | 1 PLC | ± - | 2 PLC | ± - | 3 PLC | ± .005 | 4 PLC | ± - | ANGLES | ± - | PRODUCT SPEC | SWITCH ASSY, DIP, TYPE C, 7000 SERIES, SPST, SIDE ACTUATED | |
| 0 PLC | ± - | | | | | | | | | | | | | | | |
| 1 PLC | ± - | | | | | | | | | | | | | | | |
| 2 PLC | ± - | | | | | | | | | | | | | | | |
| 3 PLC | ± .005 | | | | | | | | | | | | | | | |
| 4 PLC | ± - | | | | | | | | | | | | | | | |
| ANGLES | ± - | | | | | | | | | | | | | | | |
| MATERIAL SEE SHEET 1 | FINISH SEE SHEET 1 | APPLICATION SPEC | SIZE A2 | CAGE CODE 00779 | DRAWING NO C=5435802 | RESTRICTED TO | | | | | | | | | | |
| | | WEIGHT - | SCALE 4:1 | | SHEET 2 OF 2 | REV C | | | | | | | | | | |
| | | CUSTOMER DRAWING | | | | | | | | | | | | | | |

X-ON Electronics

Largest Supplier of Electrical and Electronic Components

Click to view similar products for [DIP Switches/SIP Switches](#) category:

Click to view products by [TE Connectivity](#) manufacturer:

Other Similar products are found below :

[78M03S](#) [79B10T](#) [8136-475G4T](#) [G7G-1A2-CB-DC12](#) [H7CZL8AC100240](#) [A7SS-M](#) [A8CA-201](#) [DRR60016](#) [DRS4016](#) [1825008-1](#) [1825444-1](#) [25.350.0653.0](#) [SDA10H1BDA](#) [97R06ST](#) [A2C-2A5](#) [1825444-7](#) [ADE08SA04](#) [ADE12S04](#) [192960010](#) [2-1825058-8](#) [25.330.0653.1](#) [25.352.0353.0](#) [CXDRIVEV2X](#) [IKN0600000](#) [IKN0800000](#) [LA2-002-DC24](#) [DBS1003](#) [438872000](#) [DRD10CRAE04](#) [DSR02T](#) [DSS 208 N](#) [E2FMX2D1M1TGJ03M](#) [NDI10H](#) [219-9MSTP](#) [204-6ES](#) [EPM02FV](#) [701521596](#) [NDS08V](#) [76SB05](#) [79A10](#) [TD06H0SK1](#) [Z7.255.9027.0](#) [1-1825058-3](#) [1825428-4](#) [219-10LPSTF](#) [E3ZG6111D03M](#) [G4D212PUSTV2DC5](#) [195-7MSTN](#) [NDI05H](#) [EPG301BT06](#)