

LOC		DIST		REVISIONS			
P	LTR	DESCRIPTION	DATE	DN	APVD		
E		REV PER ECO 10-004811	08JUL10	PY	RL		

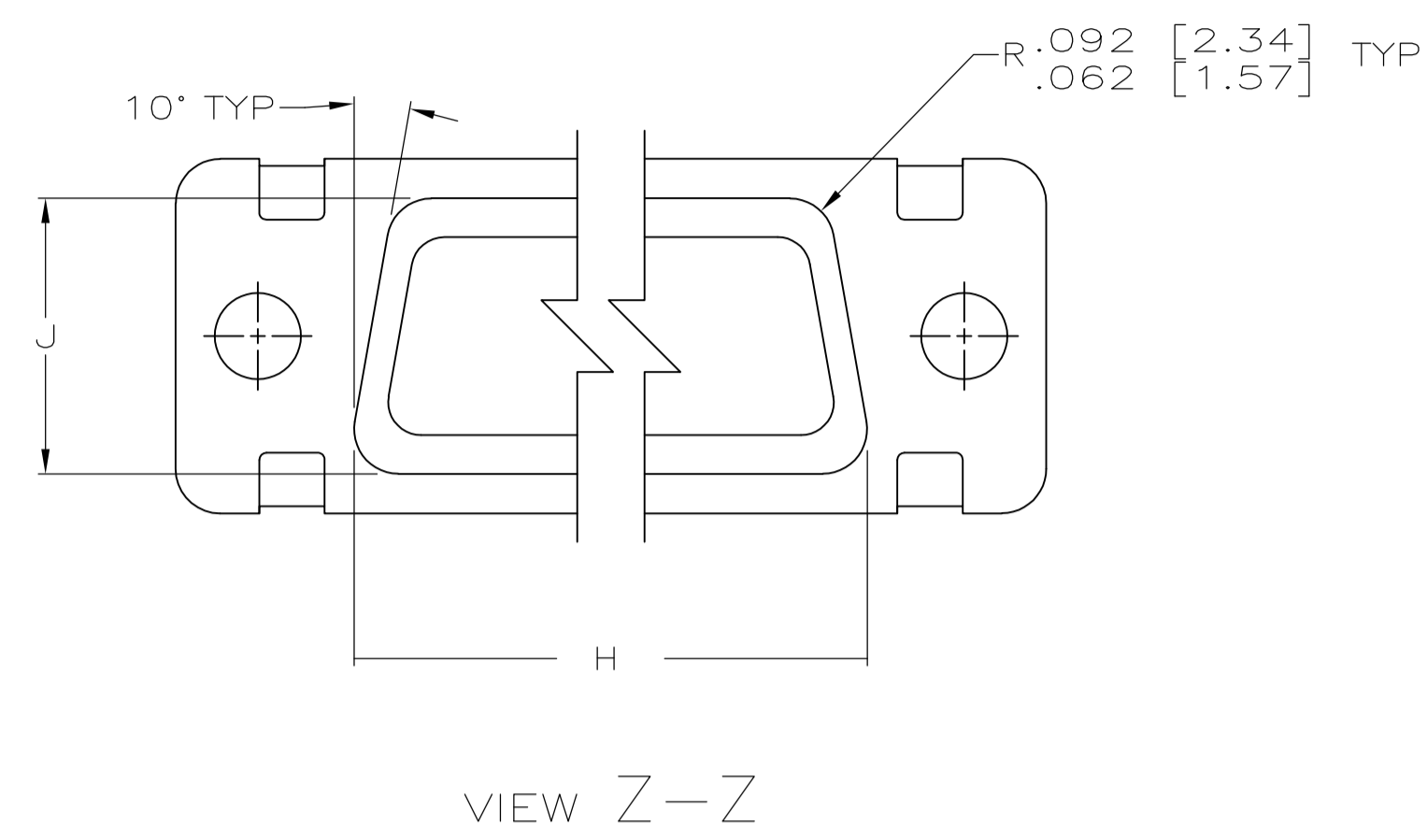

- DIMENSIONS AND TOLERANCES PER ANSI Y14.5M-1982.
- SEE SHEET 2 FOR INSERT ARRANGEMENTS.
- MARK WITH .047 [1.19]-.062 [1.57] HIGH CHARACTERS. FAR SIDE REFERS TO THE WIDE SIDE OF THE KEYSTONE. NEAR SIDE REFERS TO THE NARROW SIDE OF THE KEYSTONE. SIZE 1 AND 2 SHALL BE MARKED AS FOLLOWS:
  - A. "AMP" AND DATE CODE ON REAR SHELL, NEAR SIDE.
  - B. AMP PART NUMBER ON REAR SHELL, FAR SIDE.
- CONTACTS NOT INSTALLED IN CONNECTOR, SHOWN FOR REFERENCE ONLY.
- FINISH: CADMIUM PER QQ-P-416 OVER COPPER PER MIL-C-14550.
- FINISH: ZINC PLATED PER ASTM-B-633 .000200-.000400 THK WITH SUPPLEMENTARY CHROMATE (Cr3+).

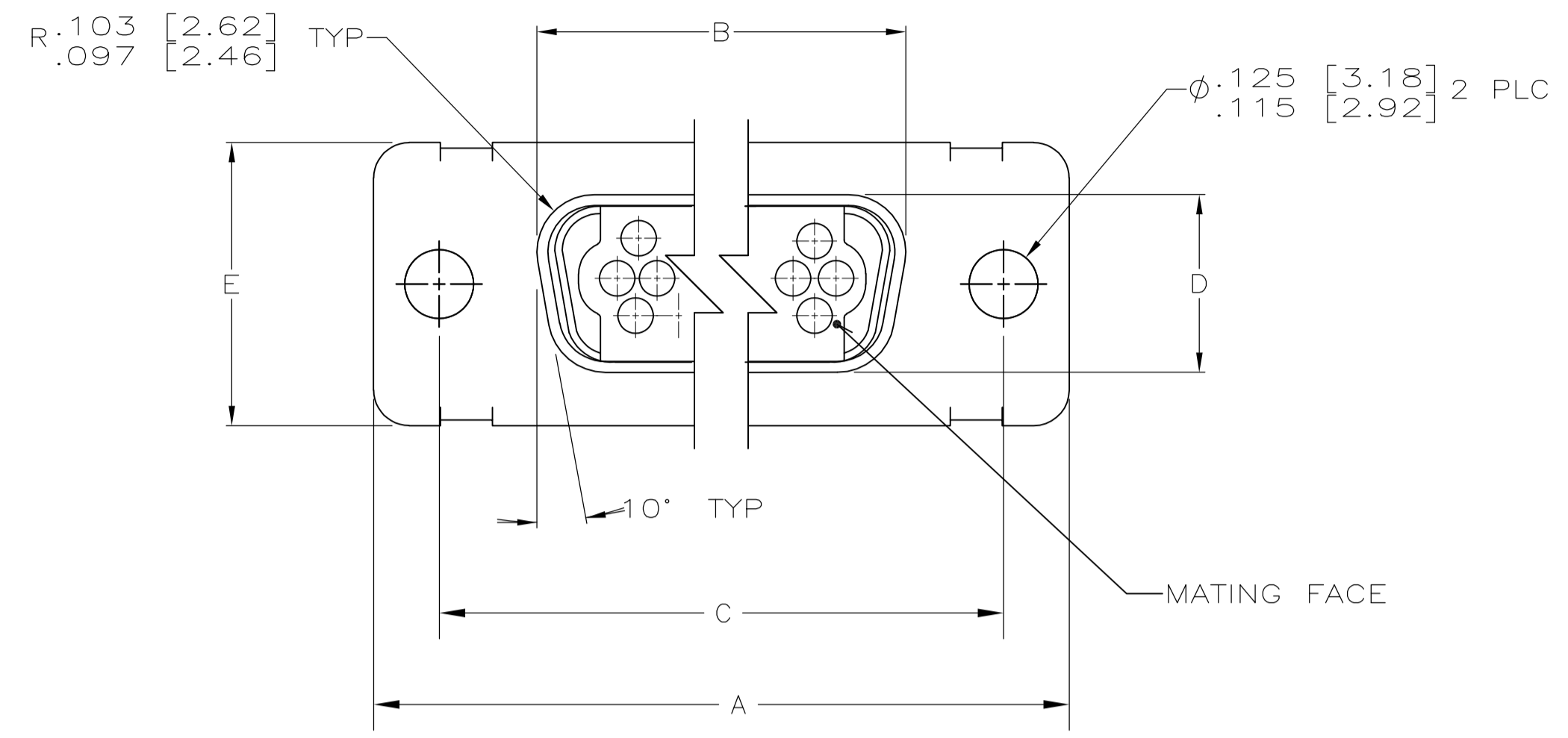
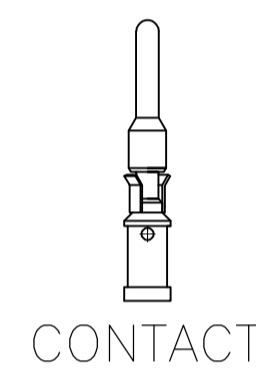
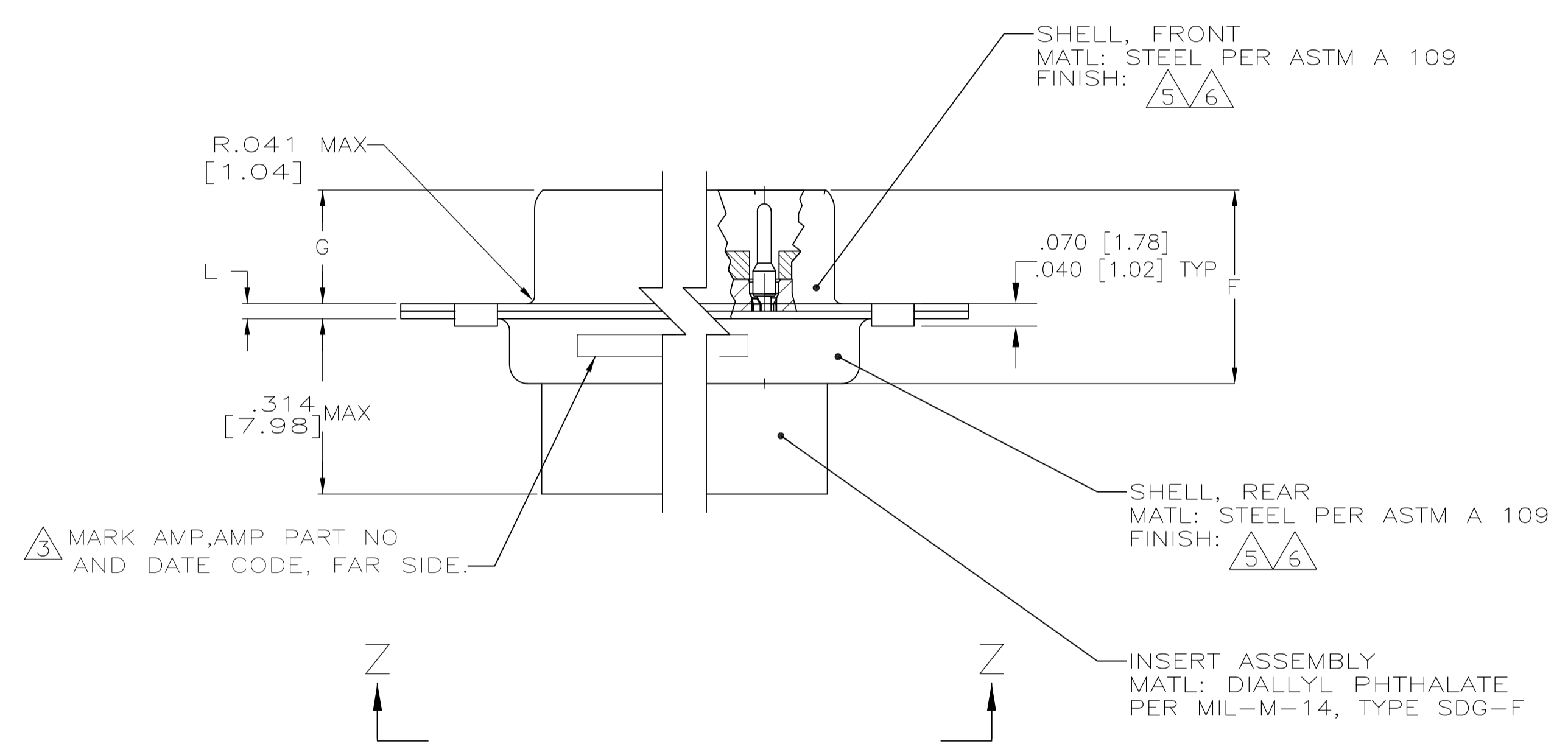

	.040 [1.02] .020 [0.51]	.432 [10.97] .412 [10.46]	.769 [19.53] .749 [19.02]			.509 [12.93] .479 [12.17]	.316 [8.03] .306 [7.77]	.989 [25.12] .979 [24.87]	.648 [16.46] .638 [16.21]	1.228 [31.19] 1.198 [30.43]	19	1	△6	5-593210-1
OBSOLETE		.544 [13.82] .524 [13.31]	2.188 [55.58] 2.168 [55.07]			.620 [15.75] .590 [14.99]	.428 [10.87] .418 [10.62]	2.411 [61.24] 2.401 [60.99]	2.069 [52.55] 2.059 [52.30]	2.650 [67.31] 2.620 [66.55]	100	5	△5	593210-5
OBSOLETE	.049 [1.24] .029 [0.74]		2.282 [57.96] 2.262 [57.45]					2.505 [63.63] 2.495 [63.37]	2.164 [54.97] 2.154 [54.71]	2.744 [69.70] 2.714 [68.94]	79	4	△5	593210-4
OBSOLETE		.432 [10.97] .412 [10.46]	1.635 [41.53] 1.615 [41.02]	.248 [6.30] .238 [6.05]	.439 [11.15] .419 [10.64]	.509 [12.93] .479 [12.17]	.316 [8.03] .306 [7.77]	1.857 [47.17] 1.847 [46.91]	1.516 [38.51] 1.506 [38.25]	2.103 [53.42] 2.073 [52.65]	52	3	△5	593210-3
	.040 [1.02] .020 [0.51]		1.093 [27.76] 1.073 [27.25]					1.317 [33.45] 1.307 [33.20]	.976 [24.79] .966 [24.54]	1.556 [39.52] 1.526 [38.76]	31	2	△5	593210-2
			.769 [19.53] .749 [19.02]					.989 [25.12] .979 [24.87]	.648 [16.46] .638 [16.21]	1.228 [31.19] 1.198 [30.43]	19	1	△5	593210-1
	L	J	H	G	F	E	D	C	B	A	NO OF POS	SHELL SIZE	PART NUMBER	

THIS DRAWING IS A CONTROLLED DOCUMENT.

DIMENSIONS: INCHES

TOLERANCES UNLESS OTHERWISE SPECIFIED:

0 PLC	± .005
1 PLC	± .004
2 PLC	± .003
3 PLC	± .002
4 PLC	± .001
ANGLES	± .001

MATERIAL: SEE CALLOUTS

FINISH: SEE CALLOUTS

THIS DRAWING IS A CONTROLLED DOCUMENT.

DIN: J.A. Baker 03-27-95

CHK: D. MANTIONE 03-27-95

APVD: -

NAME: -

PRODUCT SPEC: MIL-C-24308

APPLICATION SPEC: -

SIZE: A1

CAGE CODE: 00779

DRAWING NO: 593210

RESTRICTED TO: -

WEIGHT: -

CUSTOMER DRAWING

SCALE: 4:1

SHEET: 1 OF 2

REV: E



## X-ON Electronics

Largest Supplier of Electrical and Electronic Components

*Click to view similar products for [D-Sub Standard Connectors](#) category:*

*Click to view products by [TE Connectivity](#) manufacturer:*

Other Similar products are found below :

[DCM37S732N](#) [DAM15P500](#) [DEV09S364GTLF](#) [DEM09P032N](#) [DDM50P732N](#) [DAM15S332N](#) [173109-2218](#) [173109-2466](#) [173109-2436](#)  
[173109-2435](#) [56F706-005-LI](#) [56F711-015](#) [015-0341-000](#) [015-0372-008](#) [015-8544-011](#) [017041-0005](#) [020419-0104](#) [012-0515-000](#) [012-9507-](#)  
[034](#) [012-9507-114](#) [012-9534-001](#) [020745-0008](#) [609-25P](#) [M24308/2-23Z](#) [M243082310F](#) [M243082410F](#) [M243082411F](#) [M24308/4-21](#)  
[CT1A18-11PSA206](#) [CT1N36-5SC](#) [CT2-16S-17PS](#) [CT2-20-15PCAU](#) [CT2-24-12PS](#) [CT2-24-28PSF127A206](#) [CT2-32-9PC](#) [CT6F9767-14-4-](#)  
[14S-5PC](#) [CT6FA10SL-4PS](#) [CT7-18-10SC](#) [CT7-18-10SCAU](#) [CT7-18-12SCAU](#) [CT7-18-1PC](#) [CT7-18-1PCAU](#) [CT7-18-21SCAU](#) [M83513/01-](#)  
[FC](#) [M83723/76W24619 L/C](#) [M85049/48-3-2F](#) [69001-865](#) [6STD09PCM99B70X](#) [6STD09SCM99B30X](#) [6STD09SCT99S40X](#)