

8-Position Unshielded Slim-Line Modular Plug (MP-6AU)

NOTE

All numerical values are in metric units [with U.S. customary units in brackets]. Dimensions are in millimeters [and inches]. Figures and illustrations are for identification only and are not drawn to scale.

1. INTRODUCTION

This specification covers the requirements for application of Category 5e/6/6A Unshielded Slim-Line Modular RJ45 Plug Connectors (MP-6AU). These requirements are applicable to hand or automatic machine terminating tools. Cables approved for use with these connectors are round, twisted-pair cables, unshielded, 24-26 AWG stranded conductors and 23-26 AWG solid conductors. The insulated conductor outside diameter must be between 0.69mm and 1.09mm. The cable jacket outside diameter must be between 4.80mm and 7.90mm.

When corresponding with CommScope Connectivity Personnel, use the terminology provided in this specification to facilitate your inquiries for information. Basic terms and features of components are provided in Figure 1.

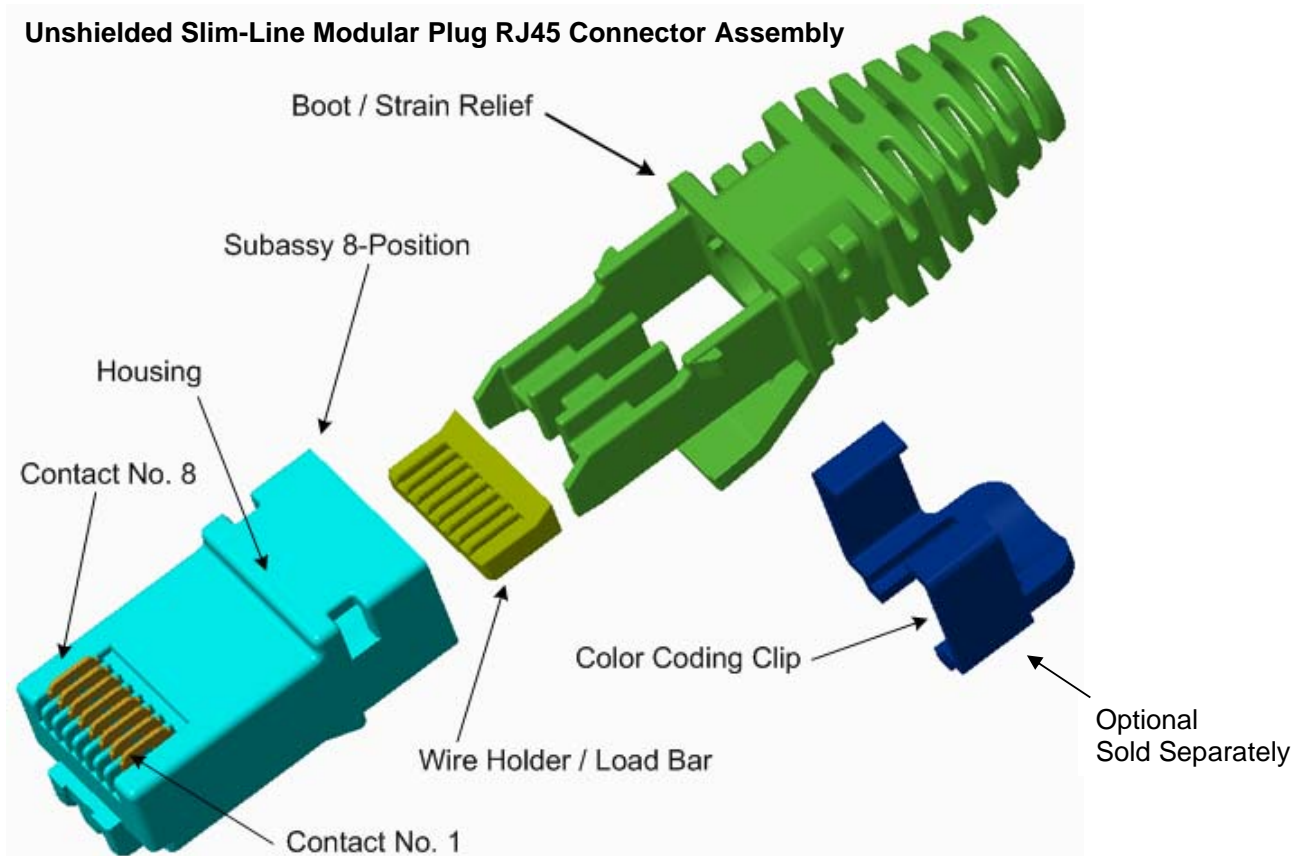

Figure 1: Basic terms and features MP-6AU

2. REFERENCE MATERIAL

2.1. Revision Summary

This paragraph is reserved for a revision summary of changes and additions made to this specification. The following changes were made for this revision:

- Removed references to discontinued tooling.

2.2. Customer Assistance

Reference Part Numbers 6-2843007 (Catalog No. MP-6AU-PLUG-A) and 6-2843008 (Catalog No. MP-6AU-PLUG-B) are representative numbers of 8-position Category 5e/6/6A Unshielded Slim-Line Modular RJ45 Plug Connectors. Use of these numbers will identify the product line and expedite your inquires through a service network established to help you obtain product and tooling information. Such information can be obtained through a local CommScope Connectivity Representative (Field Sales Engineer, Field Applications Engineer, etc.).

2.3. Drawings

Customer Drawings for specific products are available from the service network. The information contained in the Customer Drawings takes priority if there is a conflict with this specification or with any other technical documentation supplied by CommScope Connectivity.

2.4. Specifications

Product Specification 108-131013 provides product performance requirements. Product Qualification Test Report 501-131013 provides test results.

2.5. Instructional Material

The following list includes available instruction sheets (408-series) and customer manuals (409-series) that provide operation, maintenance, and repair of tooling. In addition, follow the instructions and procedures outlined in Paragraph 3.2 of this specification for product assembly procedures.

<u>Document Number</u>	<u>Document Title</u>
408-4389	Crimp Height Gage 904170-1
408-9767	Modular Plug Hand Tool Assembly X-231652-X.

3. REQUIREMENTS

3.1. Storage

A. Ultraviolet Light

Prolonged exposure to ultraviolet light may deteriorate the chemical composition used in the connector components.

B. Shelf Life

All components products should remain in the shipping containers until ready for use to prevent damage. These products should be used on a first in, first out basis to avoid storage contamination.

C. Chemical Exposure

Do not store connector components near any chemicals listed below, as they may cause stress corrosion cracking in the product.

Alkalies	Ammonia	Citrates	Phosphates	Citrates	Sulfur Compounds
Amines	Carbonates	Nitrites	Sulfur Nitrites		Tartrates

NOTE *Where the above environmental conditions exist, phosphor-bronze contacts are recommended if available.*

3.2. Cable

A. Cable Specifications

1. Cable Type: Round jacketed, Unshielded, four twisted pairs.
2. Conductor Type:
 - a. Stranded Conductor: 24-26 AWG
 - b. Solid Conductor: 23-26 AWG
3. Conductor Insulation Outside Diameter: 0.69mm -1.09mm [.027-.043] for any one conductor. See section 7 Ordering Guide.
4. Cable Jacket Insulation Diameter: 4.80mm – 7.40mm [.189 - .291]. See section 7 Ordering Guide.
5. Unshielded Type: With or without cable central filler

3.3. Terminated Connector Requirements and Process

Cable Pair Arrangement: The arrangement of color-coded pairs within the cable jacket applicable to TIA/EIA T568B wiring and the termination procedures described in this specification is shown in Figure 3. Cable end A applies to one end of the cable and cable end B to the opposite end. For TIA/EIA T568A wiring or termination of cables with pair arrangements other than TIA/EIA T568B, contact the responsible CommScope Connectivity Engineering Department.

3.4. Terminated Connector Instruction

This section provides instruction for assembly and terminated of twisted pairs cable to MP-6AU modular plug, see the following process steps below. Note that step 6 on which pairs to have no-twist and add-twist within plug boot manager section is only reference. Note that depending on the electrical characteristics of the customer twisted pair cable the no-twist and add-twist of what pair method maybe different then shown in step 6. Additionally, the position of the pairs in the pair manger described in steps 3 and 4 may also need to be altered to achieve the ultimate performance. It is the responsibility of the user to determine the optimum twist and pair layout depending upon the cable being terminated.

01

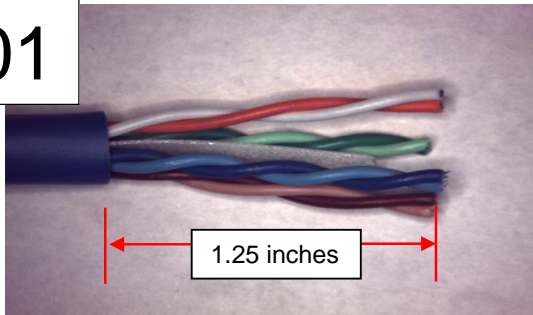

Strip cable jacket back to dimension 1.25 inch.

02



Cut away filler strip from end of cable jacket. Cut as close as you can to the edge of the cable jacket without nicking wires insulation.

03a

Blue Pair on Top
Front View

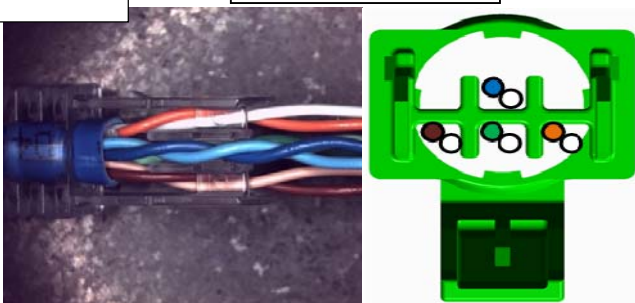

Insert cable jacket and wire pairs into boot/pair manager with **Blue** wire pair on top.

03b

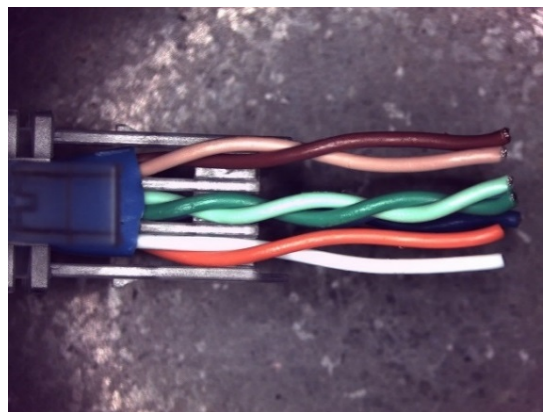

On the reverse latch side; **Orange**, **Green**, and **Brown** wire pairs are positioned as shown.

04a

Green Pair on Top
Front View

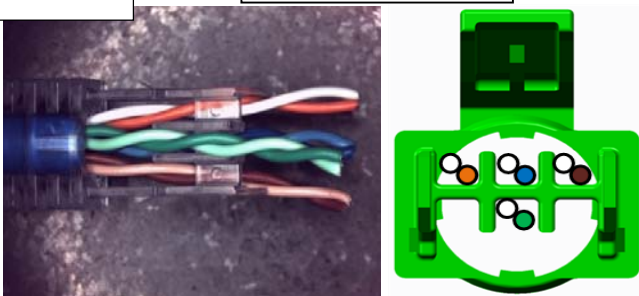

Opposite end of cordage, position **Green** wire pair on top.

04b

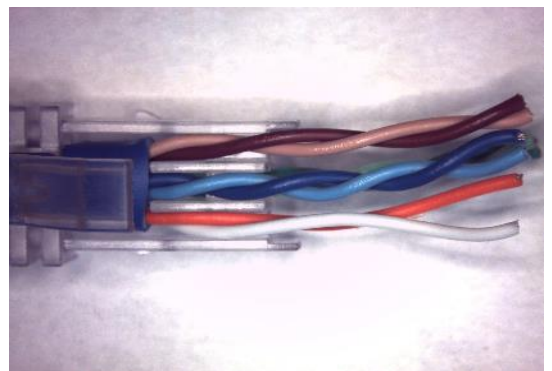

On reverse latch side wire pairs; **Orange**, **Blue**, and **Brown** are positioned as shown.

05

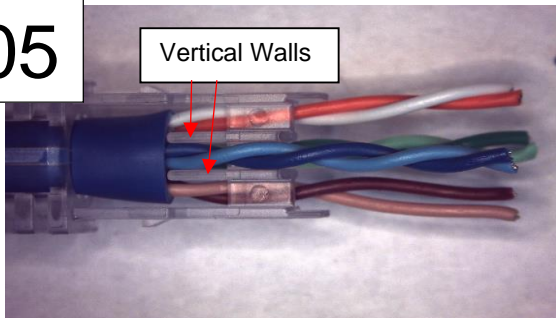

Slide boot/pair manager down to cable jacket (see step #8). Ensure vertical walls are wedged in-between wire pairs as shown.

06

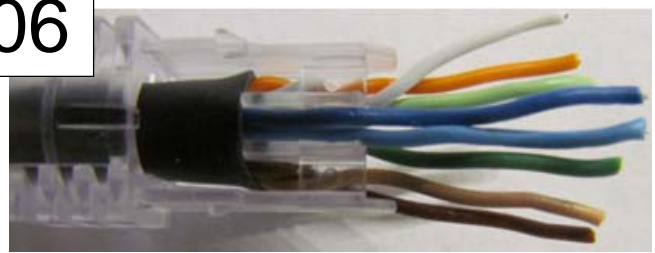

Untwist all wire pairs and **Add Twist** to **Orange** and **Brown** pairs to align with Step 7. Make sure **No Twist** in **Blue** and **Green** pairs back to jacket.

07

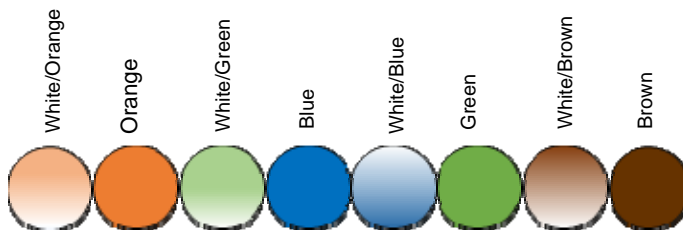

Align wires to standard T568B wiring pattern.

08

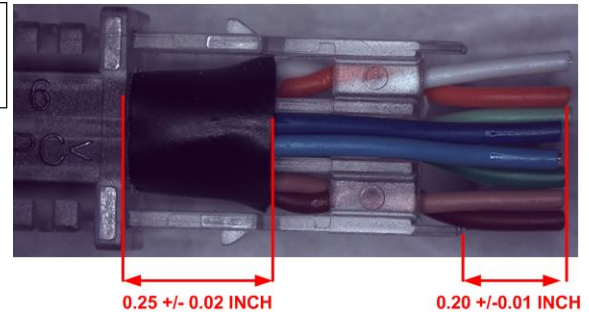

Push cable jacket to dimension 0.25 +/- 0.02 inch. Cut wires to dimension 0.20 +/- 0.01 inch.

09

0.00 TO 0.02 INCH SMALL GAP BETWEEN BOOT AND LOAD BAR

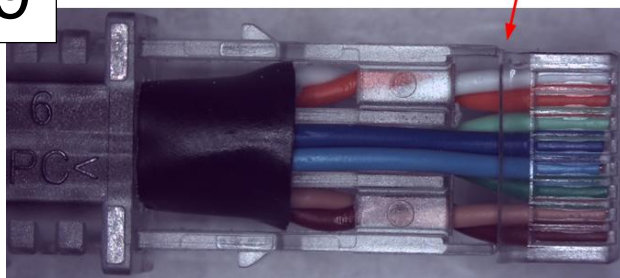

Slide wire pairs into load bar until wire insulation reaches ending point. Make sure wires are all the way into load bar housing.

10

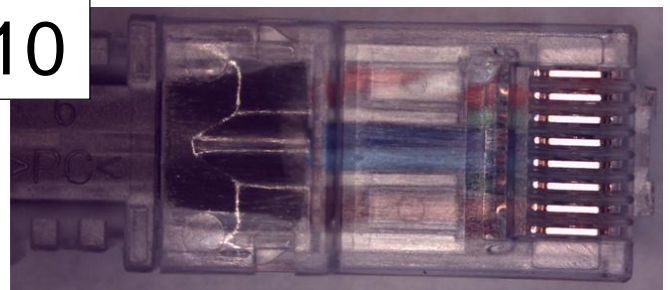

Push the plug housing over the load bar through the boot pair manger all the way until it latches to the boot. Terminate plug contacts to wire pairs with termination tool to seat the contacts.

3.4. Terminated Connector Requirements

Figure 2 shows a cutaway side view of a typical terminated plug and the required location of the plug contact. A visual check through the plastic plug housing and load bar should reveal whether the conductors are within the acceptable location.

For optimum transmission performance (acceptable location), it is preferred that all conductors be fully inserted into the plug load bar housing with the ends of the conductors bottomed against the inside front surface of the plug load bar housing. For reliable electrical termination, the conductors must at least be inserted past the plug contact within the load bar housing.

Proper crimp height can be inspected using an indicator with needle-point probes or equivalent. The crimp height shall be measured at the front of the contact as shown in Figure 16.

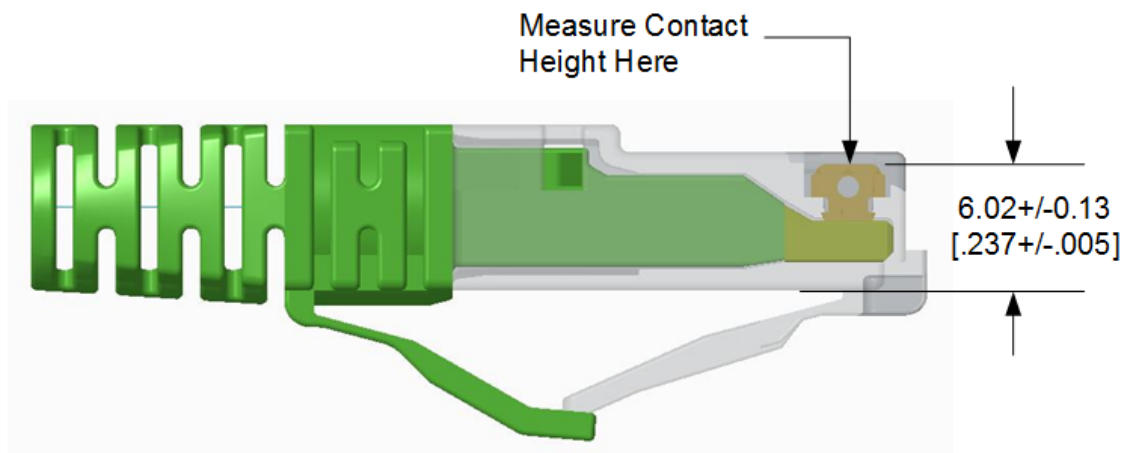

Figure 2

3.5. Repair/Replacement

Damaged components must not be used. If a damaged component is evident, it must be replaced with a new one.

4. QUALIFICATIONS

The Modular Plug Connectors are not required to be Listed or Recognized by Underwriters Laboratories Inc. (UL), or Certified to the Canadian Standards Association (CSA).

5. TOOLING

This section provides information on the hand tool to be used with these plugs.

Modular Plug Hand Tool:
Hand Tool with MP-6AU Die (PINK DOT)
 3-231652-7
Hand Tool with No Die
 2-231652-0

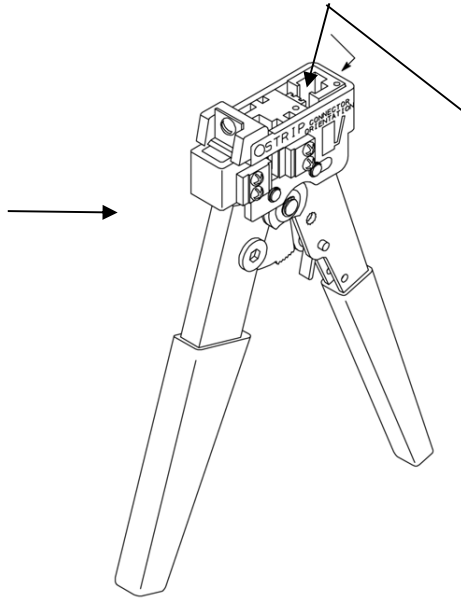

Modular Plug Die Set:
MP-6AU Die Only (PINK DOT)
 1-853400-5

HAND TOOL (DOCUMENT)	
Hand Terminator HAND TOOL	DIE SET ONLY
X-231652-X (408-9767)	1-853400-5

Figure 3: Tooling

5.1 TOOLING MODULE MODIFICATION, IF EXISTING PART NUMBERS BELOW

This section provides instruction for modification of existing dual terminating module with the following Part Numbers: [NOTE: Terminating equipment has been discontinued]

Module 1-856196-1 comes with two Primary Stuffer strain relief blocks per below in Figure 19. Remove the two Primary Stuffer strain relief blocks from module and if require replace the two #8-32UNC socket cap screws with shorter length screws.

Module 856196-2 comes with two Primary Stuffer strain relief blocks and two Secondary Stuffer strain relief blocks per below in Figure 4. Remove the two Primary Stuffer strain relief blocks and two Secondary Stuffer strain relief blocks from module and if require replace the two #8-32UNC socket cap screws with shorter length screws.

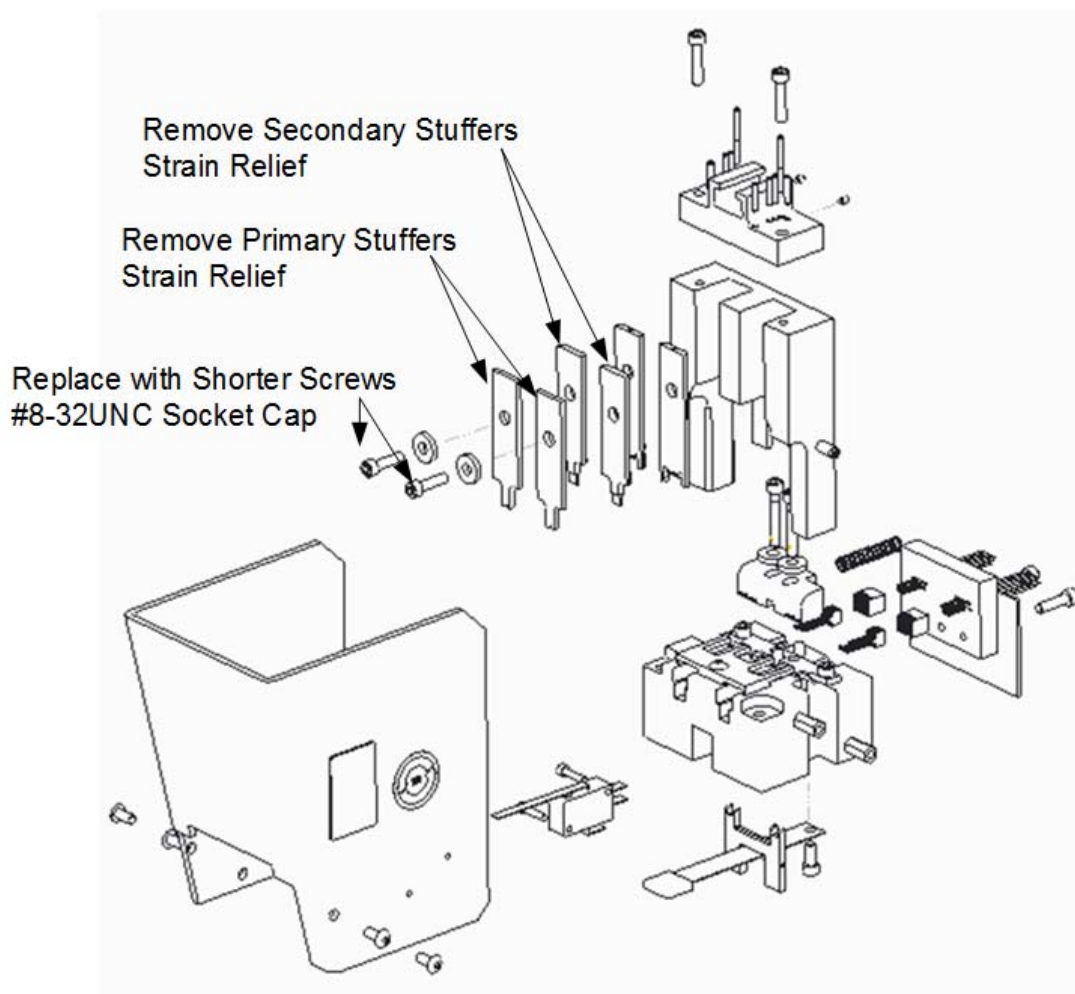

Figure 4: Tooling

6. VISUAL AID

Figure 5 shows typical applications of Modular Plug Connectors. These illustrations should be used by production personnel to ensure a correctly applied product. Applications which DO NOT appear correct should be inspected using the information in the preceding pages of this specification and in the instructional material shipped with the product or tooling.

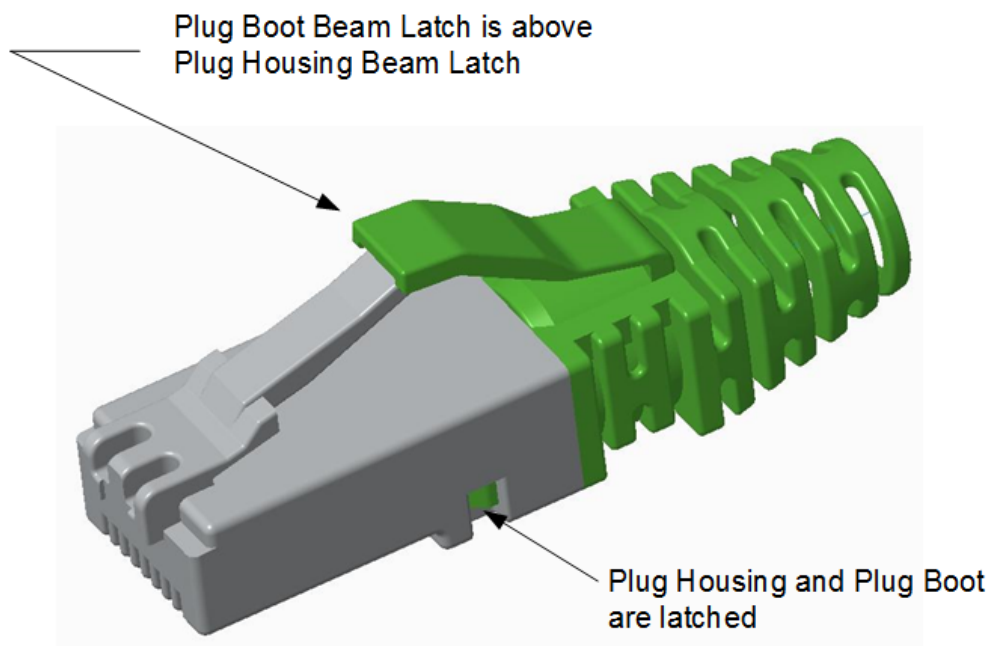
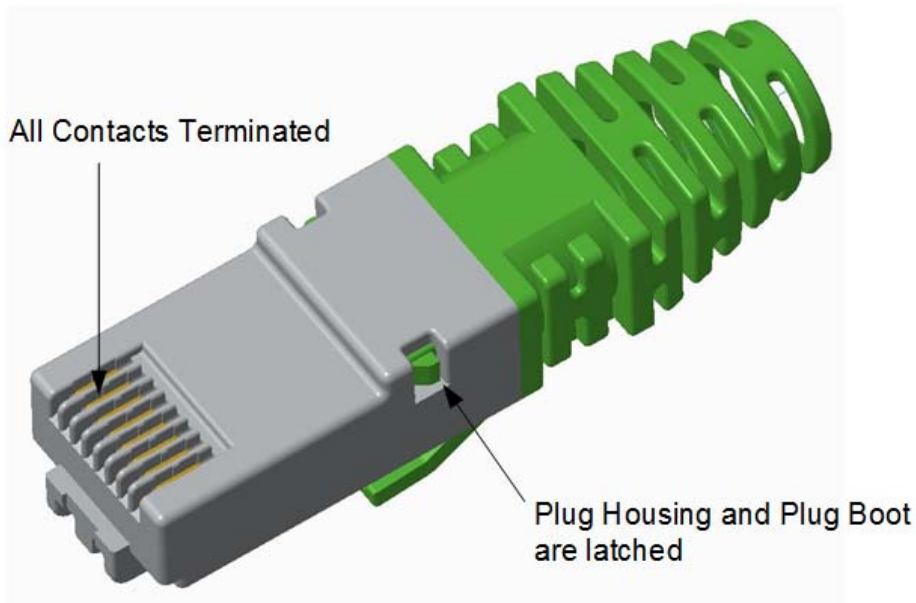

Figure 5: Visual Aid

7. Ordering Information:

MP-6AU Plug Housing with wire manager is ordered as a kit depending upon conductor diameter. MP-6AU-Boot is ordered separately based on cable diameter. See Figure 6, Both the Plug Housing/Wire Manager Kit and the Integrated Boots are sold in bags of 100.

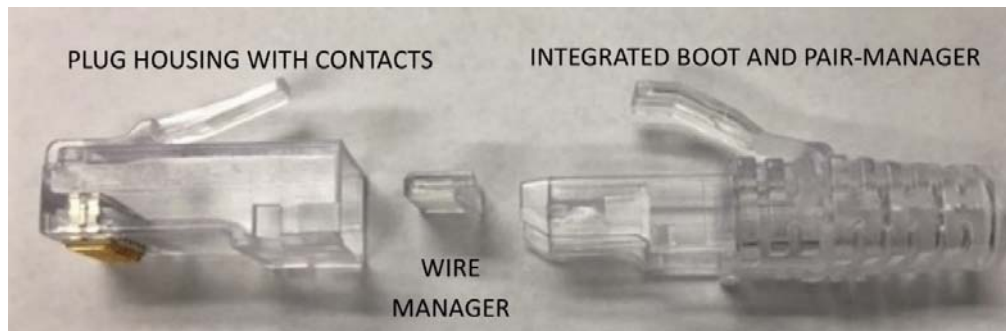

Figure 6: Visual Aid

MID	Catalog Number	Description	Conductor Insulation Diameter
6-2843007-1	MP-6AU-Plug-A-1	Plug Housing with 0.99 mm Wire-Manager	1.09 mm-0.89 mm [0.043 in – 0.035 in]
6-2843008-1	MP-6AU-Plug-B-1	Plug Housing with 0.79 mm Wire-Manager	0.89 mm - 0.69 mm [0.035 in – 0.027 in]
MID	Catalog Number	Description	Cable Diameter
2843018-3	MP-6AU-Boot-71-1	Integrated Boot and Manager, 7.1 mm	7.40 mm - 6.80 mm [0.291 in – 0.268 in]
2843020-3	MP-6AU-Boot-59-1	Integrated Boot and Manager, 5.9 mm	6.20 mm -5.60 mm [0.244 in – 0.220 in]
2843021-3	MP-6AU-Boot-54-1	Integrated Boot and Manager, 5.4 mm	5.70 mm - 5.10 mm [0.224 in – 0.201]
2843023-3	MP-6AU-Boot-51-1	Integrated Boot and Manager, 5.1 mm	5.40 mm - 4.80 mm [0.212 in – 0.189 in]

Figure 7:

8. Plug Accessories (Sold Separately)

8.1 Color Coding Clip

Figure 8 shows typical applications of Modular Plug Connector with Color Coding Clip. The color coding clip simply snaps onto the plug boot in the field by the customer and is exchangeable, latch around the plug boot. The color clips is offered in bags of 50 and come in nine (9) different colors. After the color coding clip is latch onto the plug boot, make sure color clip latches are flush to plug boot surface on each side.

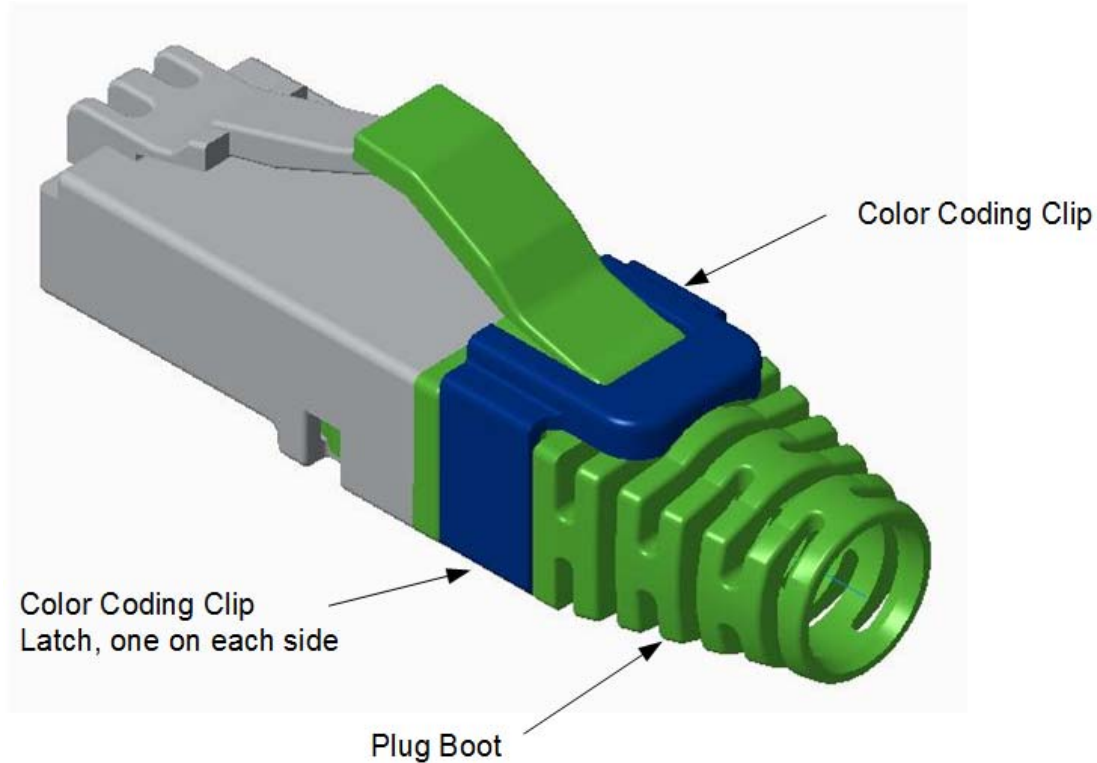

Figure 8: Modular Plug MP-6AU and MP-6AU-Boot with Color Coding Clip

MID	Color Clips	Boot Compatibility
2843022-1	MP-ColorClip-Almond-50	MP-6AU-Boot MP-BOOT-S-SL MP-5EU-Boot
2843022-2	MP-ColorClip-Black-50	
2843022-3	MP-ColorClip-White-50	
2843022-4	MP-ColorClip-Gray-50	
2843022-5	MP-ColorClip-Orange-50	
2843022-6	MP-ColorClip-Blue-50	
2843022-7	MP-ColorClip-Red-50	
2843022-8	MP-ColorClip-Yellow-50	
2843022-9	MP-ColorClip-Green-50	

Figure 9:

X-ON Electronics

Largest Supplier of Electrical and Electronic Components

Click to view similar products for [Headers & Wire Housings](#) category:

Click to view products by [TE Connectivity](#) manufacturer:

Other Similar products are found below :

[57102-F02-18ULF](#) [58102-G61-06LF](#) [582553-1](#) [009176003701906](#) [01.001.5753.1](#) [0050291907](#) [02.125.8002.8](#) [609-3404](#) [61062-3](#)
[CSU011177004](#) [622-0430](#) [622-3653LF](#) [63453-116](#) [636-1030](#) [636-1427](#) [636-3427](#) [636-4007](#) [641938-9](#) [65495-038](#) [65692-001LF](#) [65781-018](#)
[65781-047](#) [65817-010LF](#) [65817-015LF](#) [66207-023LF](#) [67095-007LF](#) [67601157](#) [68631-112](#) [68645-018](#) [699319-000](#) [70.362.1628.0](#) [70-4210](#)
[70-4226B](#) [70-4853B](#) [707-5020](#) [707-5028](#) [71.350.2428.0](#) [71961-016LF](#) [733-134](#) [733-162](#) [754199-000](#) [760-3052](#) [800-90-001-10-001000](#)
[801-43-002-10-013000](#) [801-43-006-10-002000](#) [803-41-018-10-001000](#) [803-43-024-10-001000](#) [803-93-012-10-001000](#) [8-1437020-4](#)
[819-22-004-30-001101](#)