

LOC	DIST	P	F	ZONE	LTR	REVISIONS	DATE	APPD
CM	54					5 REV PER EC 061B-0221-98	26-FEB-99	JH RS

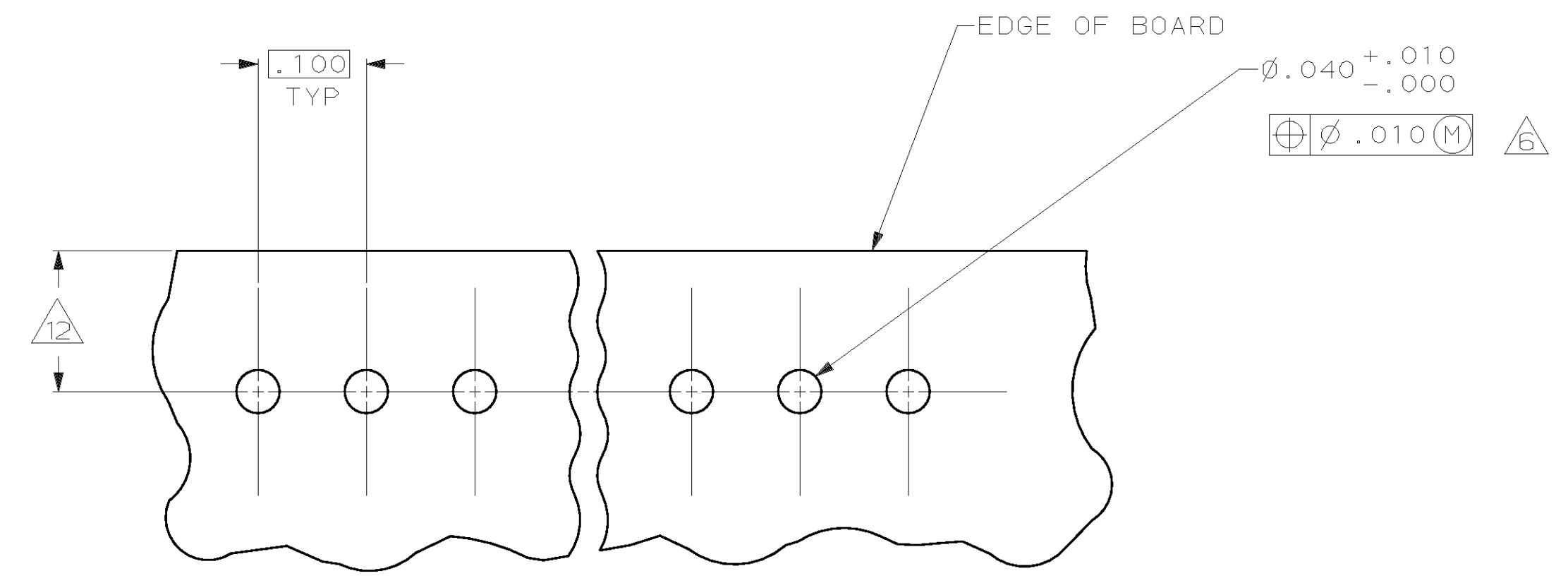
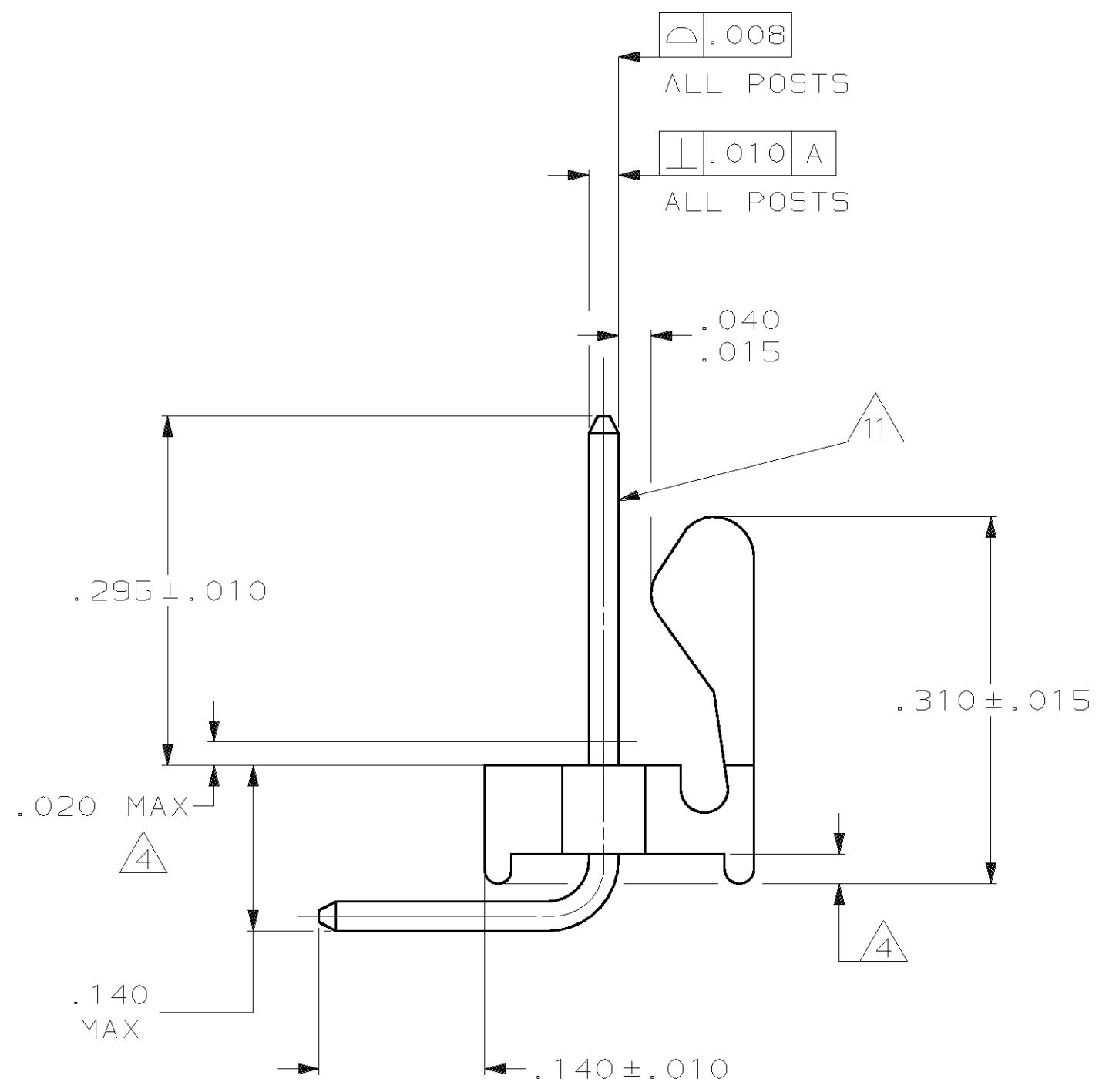
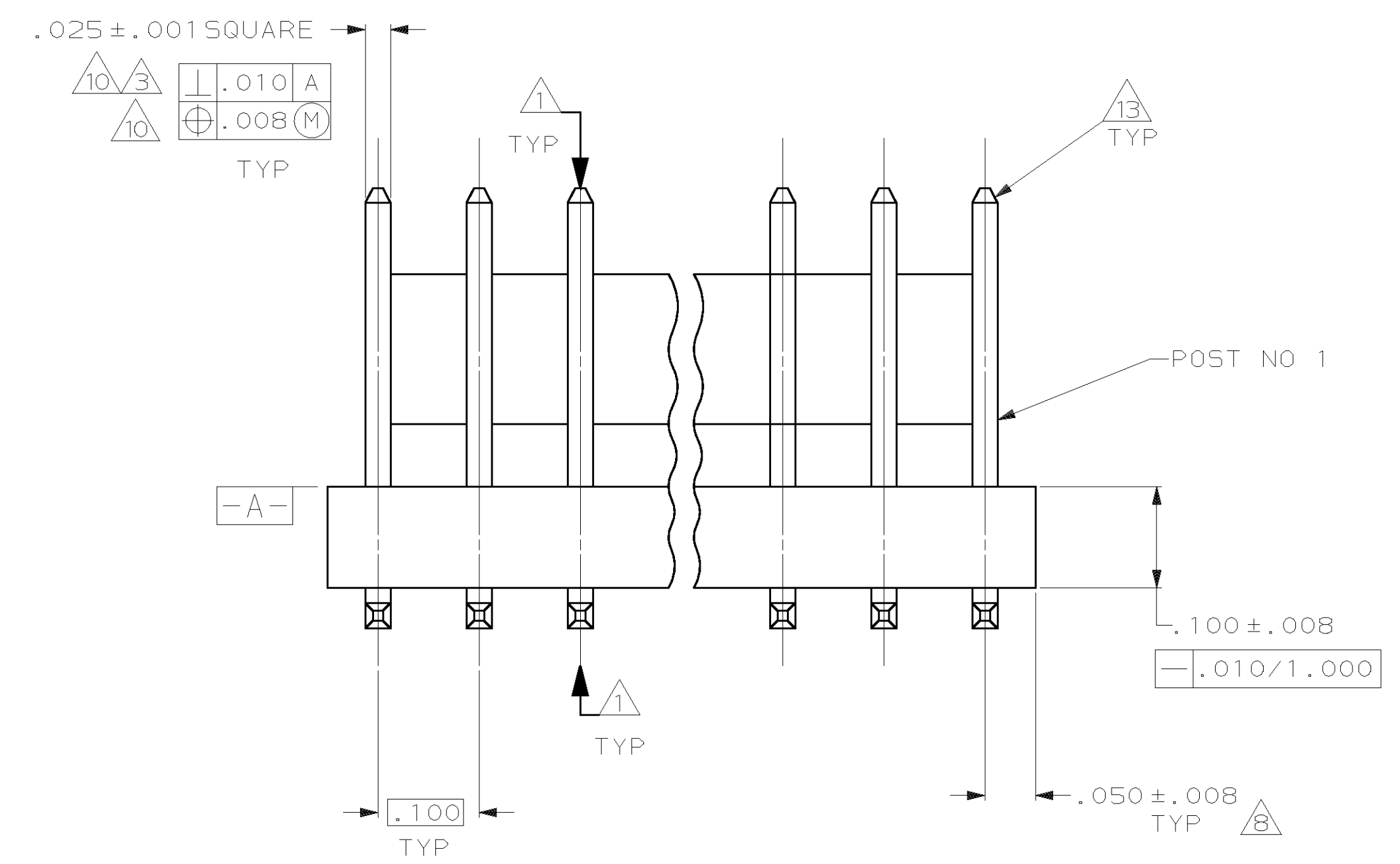
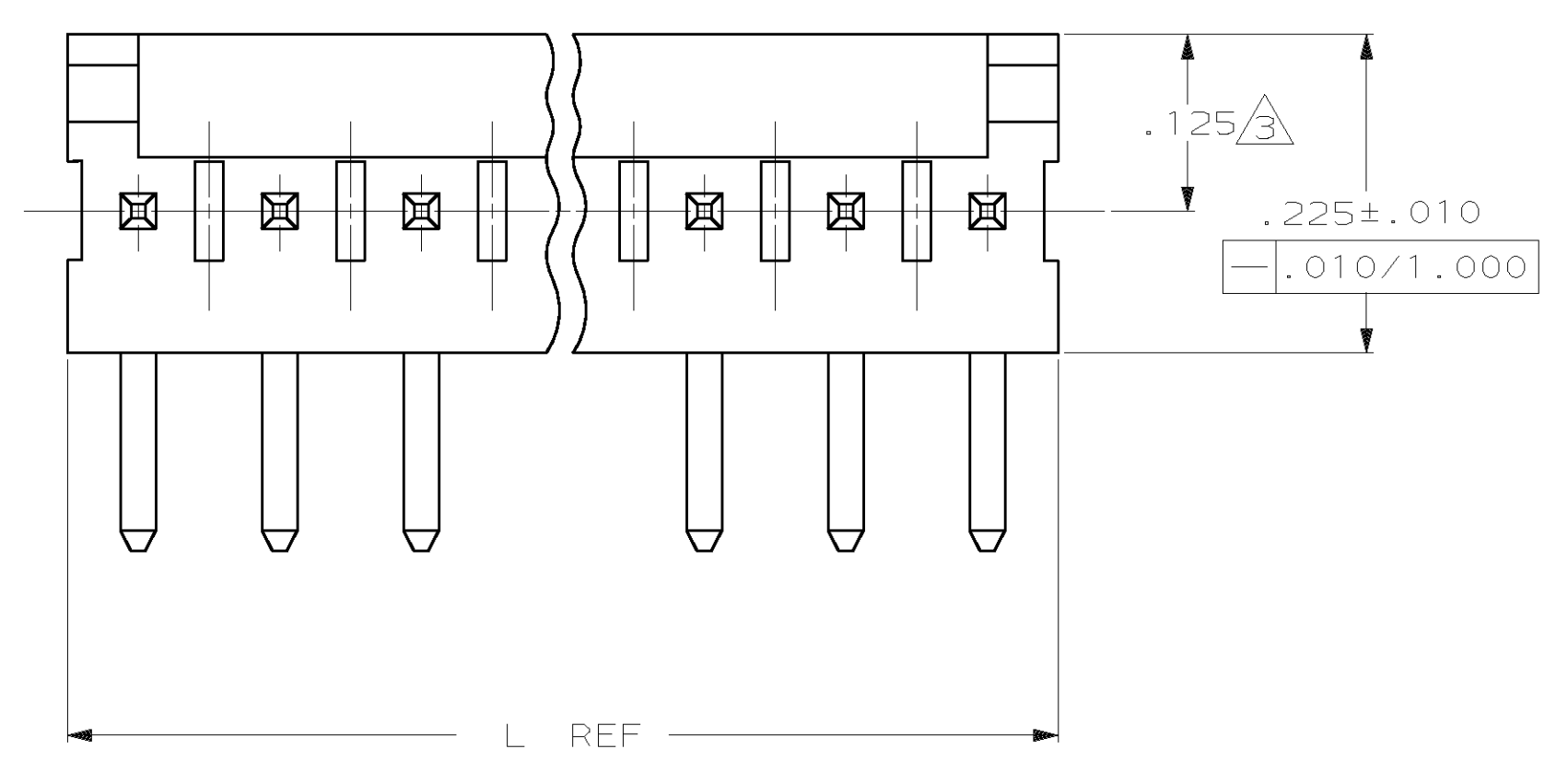

RECOMMENDED MOUNTING HOLE PATTERN FOR .063 THICK P.C. BOARD

- 1 POST TO WITHSTAND 13 NEWTONS (3LBS.) MIN. AXIAL FORCE IN BOTH DIRECTIONS SHOWN WITHOUT DISLODGING.
- 2 TOLERANCES APPLY TO SOLDER SIDE OF BOARD.
- 3 MEASURED AT SURFACE -A-
- 4 PLASTIC FLASH PERMITTED IN THIS AREA.
- 5 PARTS COMPLY WITH AMP SOLDERABILITY SPEC. NO. 109-11-2.
- 6 ONE HOLE MAY BE UNDERSIZED (.035/.032 DIA.) FOR ASSEMBLY RETENTION DURING WAVE SOLDERING.
- 7 MATERIAL: HEADER-THERMOPLASTIC POLYESTER 94V-0 (NATURAL)
POST-COPPER ALLOY (TIN PLATED)
- 8 COORDINATE DIMENSION APPLIES FROM CENTER OF ACTUAL FEATURE.
- 9 PLASTIC BURRS CAUSED BY CUT-OFF TOOLING ARE PERMITTED WITHIN THE MAXIMUM TOLERANCE ENVELOPE.
- 10 POST TO BE MEASURED WHEN STRIP IS HELD FLAT.
- 11 POST MUST WITHSTAND TWO 90° BENDS AGAINST EXTRUSION WITHOUT BREAKING.
- 12 DIMENSION SHOULD BE .110-.160 WHEN MATING WITH A MTA 100 CONNECTOR ASSEMBLY OR .110-.120 WHEN MATING WITH A CST 100 CONNECTOR.
- 13 PIN BURR OF .005 MAX. VERTICAL AND .003 MAX. HORIZONTAL PERMITTED AT POST TIPS ON BOTH ENDS.

IN	MM	NO OF POSITIONS	PART NUMBER
2.800	71.12	28	2-640457-8
2.700	68.58	27	2-640457-7
2.600	66.04	26	2-640457-6
2.500	63.50	25	2-640457-5
2.400	60.96	24	2-640457-4
2.300	58.42	23	2-640457-3
2.200	55.88	22	2-640457-2
2.100	53.34	21	2-640457-1
2.000	50.80	20	2-640457-0
1.900	48.26	19	1-640457-9
1.800	45.72	18	1-640457-8
1.700	43.18	17	1-640457-7
1.600	40.64	16	1-640457-6
1.500	38.10	15	1-640457-5
1.400	35.56	14	1-640457-4
1.300	33.02	13	1-640457-3
1.200	30.48	12	1-640457-2
1.100	27.94	11	1-640457-1
1.000	25.40	10	1-640457-0
.900	22.86	9	640457-9
.800	20.32	8	640457-8
.700	17.78	7	640457-7
.600	15.24	6	640457-6
.500	12.70	5	640457-5
.400	10.16	4	640457-4
.300	7.62	3	640457-3
.200	5.08	2	640457-2

IN	MM	IN	MM
1.000	25.40		
.040	1.02	.310	7.87
.035	0.89	.295	7.49
.032	0.81	.225	5.72
.025	0.64	.160	4.06
.020	0.51	.140	3.56
.015	0.38	.125	3.18
.010	0.25	.120	3.05
.008	0.20	.110	2.79
.005	0.13	.100	2.54
.003	0.08	.063	1.60
.001	0.03	.050	1.27

METRIC

THIS DRAWING IS A CONTROLLED DOCUMENT FOR AMP INCORPORATED. IT IS SUBJECT TO CHANGE AND THE CONTROLLING ENGINEERING ORGANIZATION SHOULD BE CONTACTED FOR THE LATEST REVISION.

DO NOT SCALE PRINT. UNLESS SPECIFIED DIMENSIONS IN mm [INCHES] TOLERANCES ON:		DR 2-12-93 B. LEWIS		PART NO	
2 PLC DEC ±		CHK 2-12-93 R. SWING		AMP Incorporated Harrisburg, PA 17105-3508	
3 PLC DEC ± .005		APPD 3-11-93 R. SPEER			
ANGLES ± 0°30'		APPD 3-11-93 R. SPEER			
MATERIAL	FINISH	PRODUCT SPEC	APPLICATION SPEC	SIZE	CAGE CODE
				D	00779
				DRAWING NO	
				C-640457	
				SCALE	8:1
				SHEET	1 OF 1

X-ON Electronics

Largest Supplier of Electrical and Electronic Components

Click to view similar products for [Headers & Wire Housings](#) category:

Click to view products by [TE Connectivity](#) manufacturer:

Other Similar products are found below :

[95000-104TRLF](#) [10135584-644402LF](#) [DF62W-EP2022PCA](#) [95000-106TRLF](#) [DF62W-2022SCA](#) [DF62W-EP2022PC](#) [2203348](#) [DF62W-2022SC](#) [1084018](#) [1029039](#) [1084017](#) [802-10-012-10-002000](#) [1112640](#) [1112639](#) [000-34000](#) [0009482033](#) [0009507031](#) [57102-S06-03LF](#) [57202-S52-04LF](#) [PCN6-15S-2.5E](#) [0039019024](#) [58102-G61-06LF](#) [582553-1](#) [0009485154](#) [0009508121](#) [0022285053](#) [0050291907](#) [018731A](#) [LY20-4P-DT1-P1E-BR](#) [02.125.8002.8](#) [60101931](#) [60598-1 \(Cut Strip\)](#) [M1625-3R/100](#) [61062-3](#) [61082-181009](#) [636-1427](#) [638009-1](#) [641938-9](#) [641991-4](#) [644168-1](#) [647662-1](#) [65039-019ELF](#) [65817-002LF](#) [65817-015LF](#) [65863-015LF](#) [66207-023LF](#) [67016-026LF](#) [67046-001LF](#) [67095-007LF](#) [67230-005LF](#)