

POSSIBLE MARKING CONFIGURATIONS  
SCALE 5:1

- 1 MATERIAL: HEADER- POLYESTER UL94V-0 (BLACK)  
POST- COPPER ALLOY.
- 2 SOLDER SIDE OF P.C. BOARD SHOWN.
- 3 PARTS COMPLY WITH AMP SOLDERABILITY SPEC 109-11-12.
- 4 ONE HOLE MAY BE UNDERSIZED (.032-.035 DIA) FOR ASSEMBLY RETENTION DURING WAVE SOLDERING.
- 5 LATCH DETENT FEATURE OCCURS 2 PLACES ON EACH END (MAXIMUM OF FOUR PER PART). FOR 2 THRU 5 CIRCUIT HEADERS, LATCH FEATURE OCCURS BETWEEN EACH CIRCUIT.
- 6 COORDINATE DIMENSION APPLIES FROM CENTER OF ACTUAL FEATURE.
- 7 POST: 100% MATTE TIN PLATED.
- 8 POST MUST WITHSTAND 3.0 LBS (13 NEWTONS) MIN FORCE WITHOUT DISLODGING, EITHER DIRECTION.
- 9 UL AND CSA LOGO WILL APPEAR IN THIS AREA. AMP LOGO MAY APPEAR IN THIS AREA OR ON BOTTOM OF PART.
- 10 TWO SIDES OF TAPER, AS SHOWN, MUST BE PLATED. TYPICAL, BOTH ENDS.
- 11 TWO SIDES OF TAPER, AS SHOWN, AND TIP MAY BE UNPLATED. TYPICAL, BOTH ENDS.
- 12 POST: MATTE TIN-LEAD (93/7) PLATED.
- 13 OBSOLETE PART NUMBER.

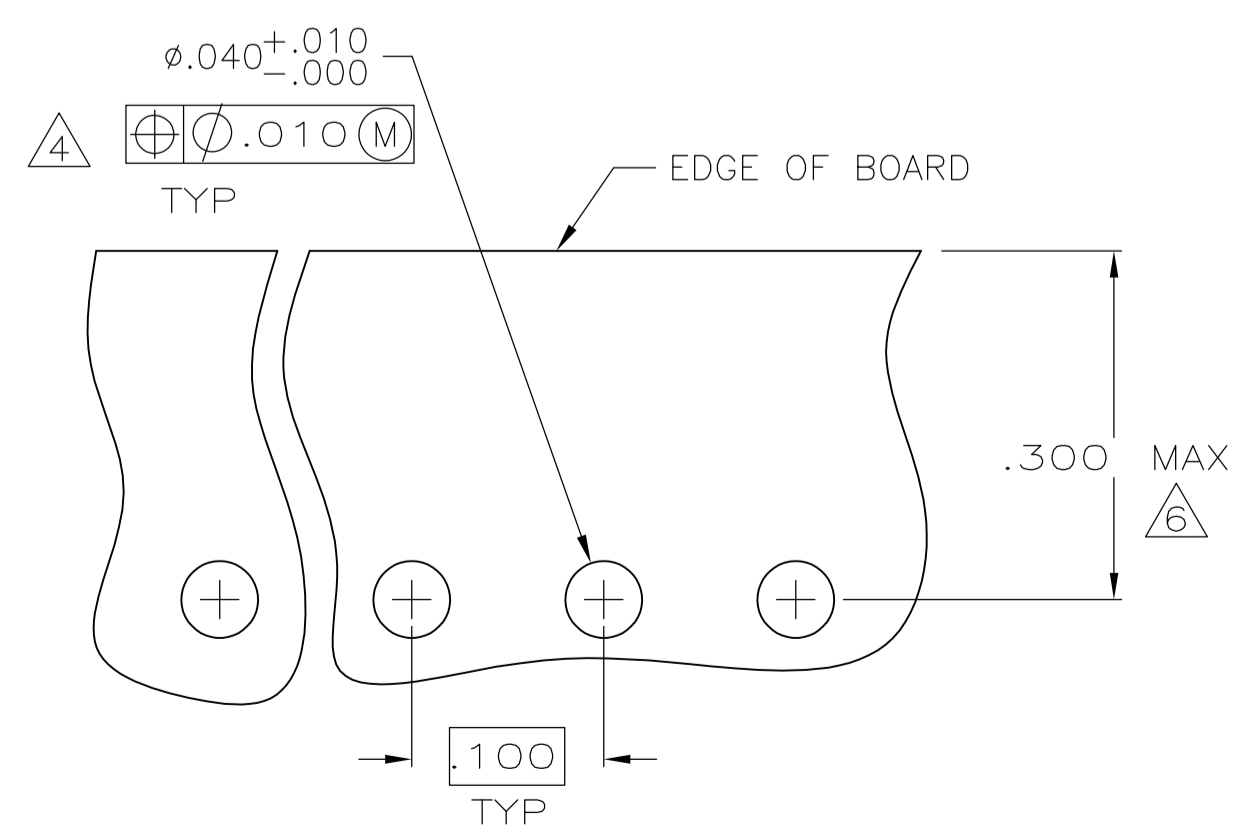
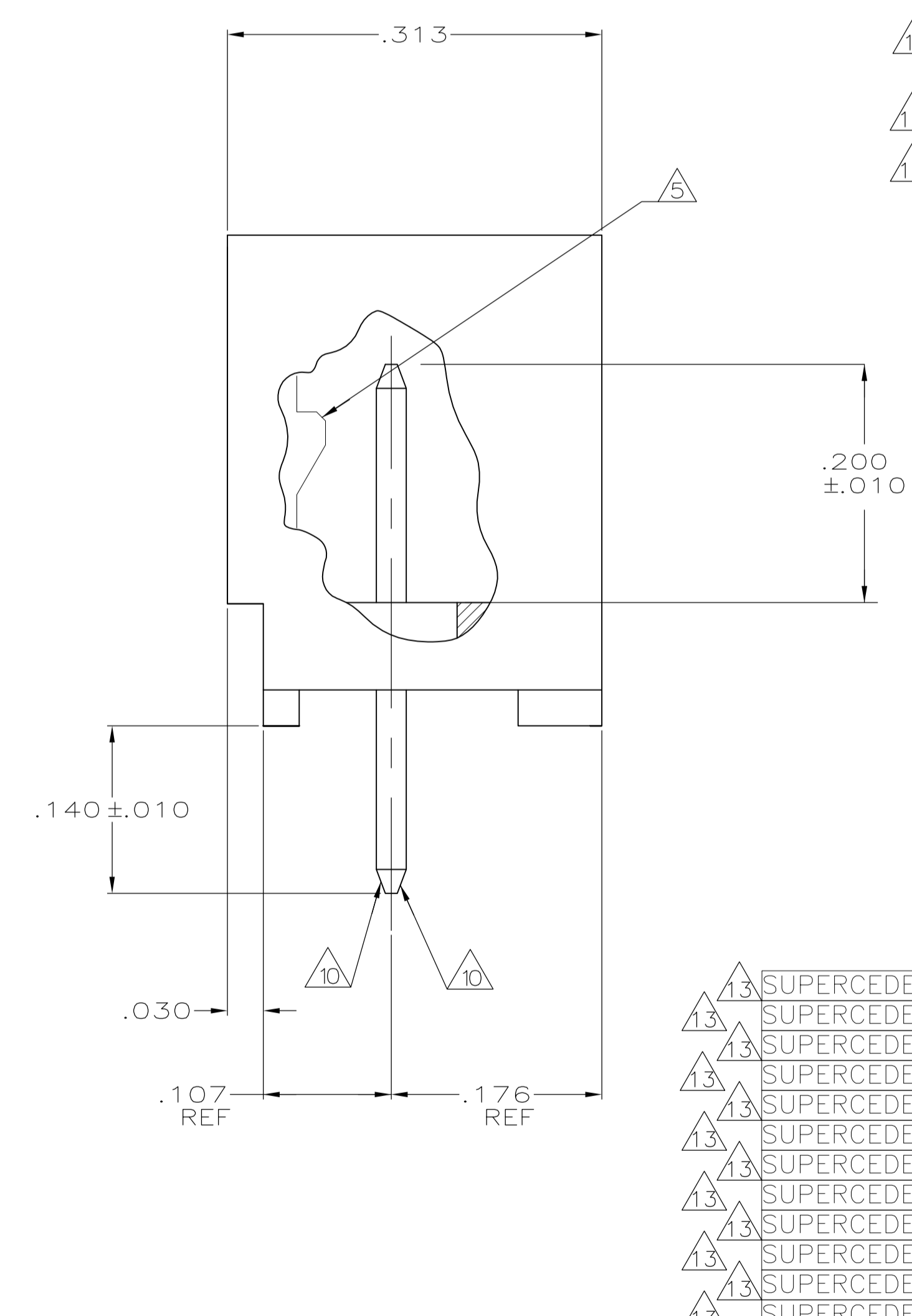
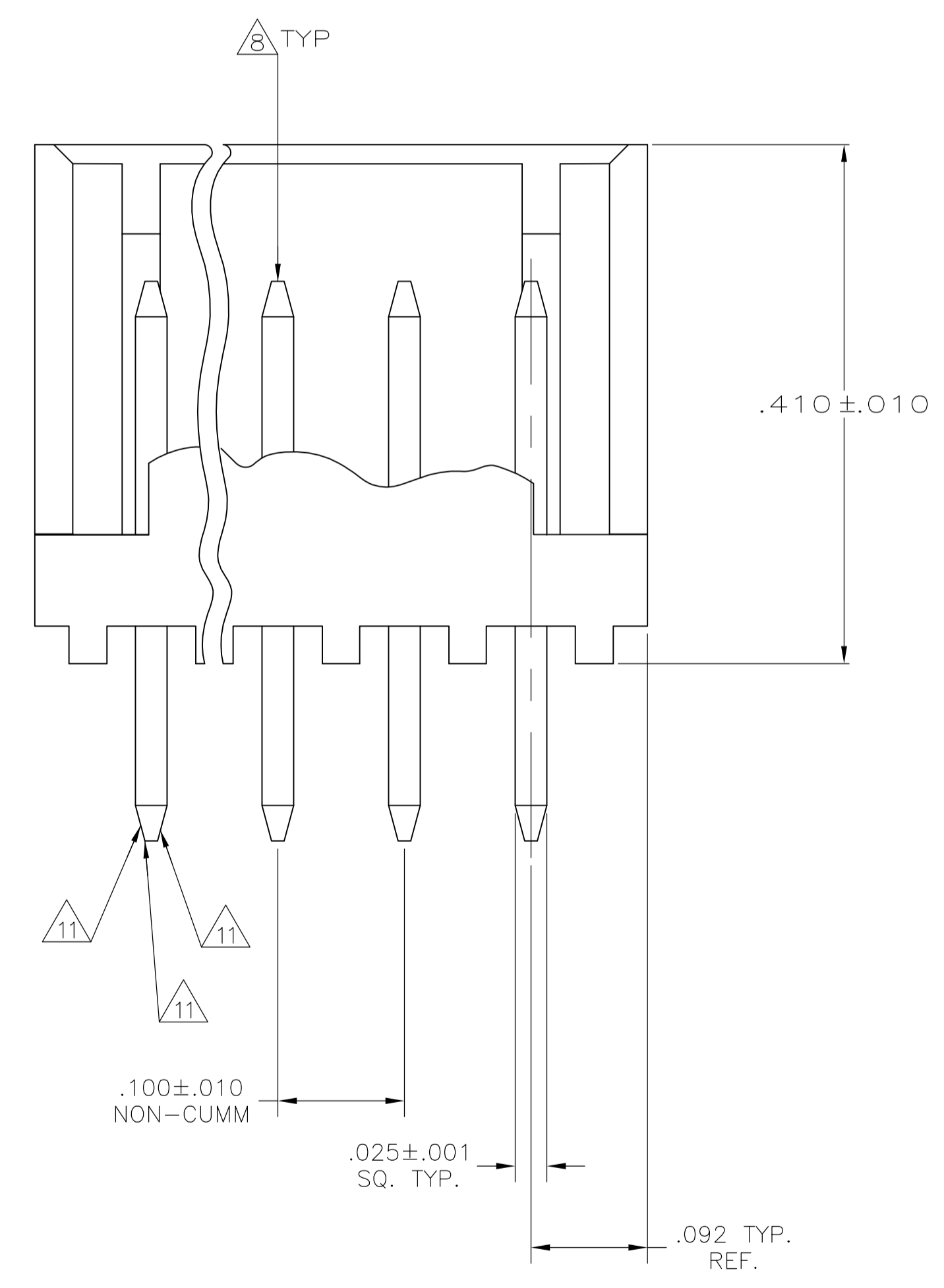

RECOMMENDED MOUNTING HOLE PATTERN FOR .063 THK PRINTED CIRCUIT BOARD

	.035	0.89	.176	4.47	—	—
	.032	0.81	.140	3.56	—	—
	.030	0.76	.107	2.72	—	—
	.025	0.64	.100	2.54	—	—
	.010	0.25	.092	2.34	.410	10.41
	.005	0.13	.063	1.6	.313	7.95
	.001	0.03	.050	1.27	.300	7.62
	.000	0	.040	1.02	.200	5.08
	IN	MM	IN	MM	IN	MM

CONVERSION TABLE

13	SUPERCEDED BY 3-644861-4
13	SUPERCEDED BY 3-644861-3
13	SUPERCEDED BY 3-644861-2
13	SUPERCEDED BY 3-644861-1
13	SUPERCEDED BY 3-644861-0
13	SUPERCEDED BY 2-644861-9
13	SUPERCEDED BY 2-644861-8
13	SUPERCEDED BY 2-644861-7
13	SUPERCEDED BY 2-644861-6
13	SUPERCEDED BY 2-644861-5
13	SUPERCEDED BY 2-644861-4
13	SUPERCEDED BY 2-644861-3
13	SUPERCEDED BY 2-644861-2

YES	7	1.484	37.69	14	3-644861-4
		1.384	35.15	13	3-644861-3
		1.284	32.61	12	3-644861-2
		1.184	30.07	11	3-644861-1
		1.084	27.53	10	3-644861-0
		.984	24.99	9	2-644861-9
		.884	22.45	8	2-644861-8
		.784	19.91	7	2-644861-7
		.684	17.37	6	2-644861-6
		.584	14.83	5	2-644861-5
		.484	12.29	4	2-644861-4
		.384	9.75	3	2-644861-3
		.284	7.21	2	2-644861-2
NO	12	1.484	37.69	14	1-644861-4
		1.384	35.15	13	1-644861-3
		1.284	32.61	12	1-644861-2
		1.184	30.07	11	1-644861-1
		1.084	27.53	10	1-644861-0
		.984	24.99	9	644861-9
		.884	22.45	8	644861-8
		.784	19.91	7	644861-7
		.684	17.37	6	644861-6
		.584	14.83	5	644861-5
		.484	12.29	4	644861-4
		.384	9.75	3	644861-3
		.284	7.21	2	644861-2

LEADFREE	FINISH	IN	MM	NO OF POSITIONS	PART NUMBER
		L		HEADER ASSEMBLY	

THIS DRAWING IS A CONTROLLED DOCUMENT.

DIMENSIONS: INCHES TOLERANCES UNLESS OTHERWISE SPECIFIED:

0 PLC	± .005
1 PLC	± .005
2 PLC	± .005
3 PLC	± .005
4 PLC	± .005
ANGLES	± .005

MATERIAL: 1 FINISH: SEE TABLE

WEIGHT: A1 00779 C=644861

CUSTOMER DRAWING SCALE 10:1 SHEET 1 OF 1 REV N

DIN S. CARPENTER 28MAY2003  
CHK: D. ROSSI 28MAY2003  
APP'D: D. ROSSI 28MAY2003  
NAME: MTA-100 SHROUDED HEADER ASSEMBLY, FRICTION LOCK, STRAIGHT POST, TIN OR TIN LEAD PLATED

STE TE Connectivity

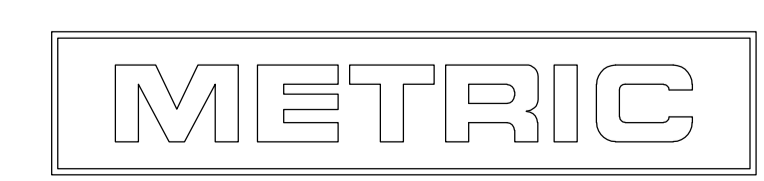

## X-ON Electronics

Largest Supplier of Electrical and Electronic Components

*Click to view similar products for [Headers & Wire Housings](#) category:*

*Click to view products by [TE Connectivity](#) manufacturer:*

Other Similar products are found below :

[95000-104TRLF](#) [10135584-644402LF](#) [DF62W-EP2022PCA](#) [95000-106TRLF](#) [DF62W-2022SCA](#) [DF62W-EP2022PC](#) [2203348](#) [DF62W-2022SC](#) [1084018](#) [1029039](#) [1084017](#) [802-10-012-10-002000](#) [1112640](#) [1112639](#) [000-34000](#) [0009482033](#) [0009507031](#) [57102-S06-03LF](#) [57202-S52-04LF](#) [PCN6-15S-2.5E](#) [0039019024](#) [58102-G61-06LF](#) [582553-1](#) [0009508121](#) [0050291907](#) [018731A](#) [LY20-4P-DT1-P1E-BR](#) [02.125.8002.8](#) [60101931](#) [60598-1 \(Cut Strip\)](#) [M1625-3R/100](#) [61062-3](#) [61082-181009](#) [636-1427](#) [638009-1](#) [641938-9](#) [641991-4](#) [644168-1](#) [647662-1](#) [65039-019ELF](#) [65817-002LF](#) [65817-015LF](#) [65863-015LF](#) [66207-023LF](#) [67016-026LF](#) [67046-001LF](#) [67095-007LF](#) [68002-116](#) [68016-236H](#) [68648-049](#)