

LOC		DIST		REVISIONS			
AD	00	REV	DATE	BY	CHK	APPV	
B1		REVISED PER ECR-10-000455	07JAN2010	JY	SY		
C		ECR-10-019054	15SEP10	SW	MQW		
D		ECR-12-010652	06NOV12	SY	AC		

### CONNECTOR ASSEMBLY EXAMPLARY LOADED

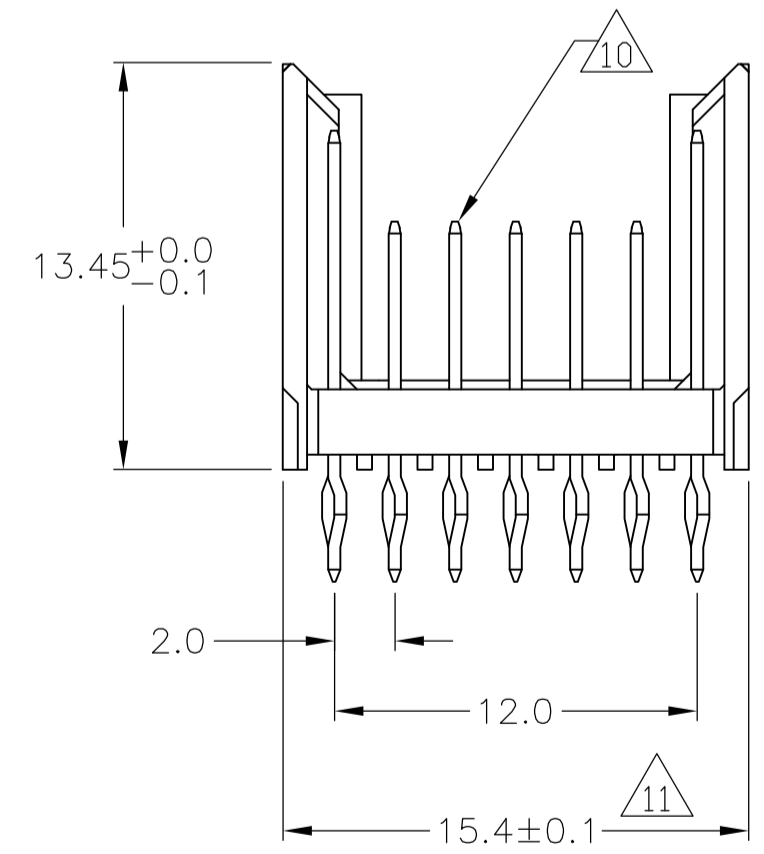

### CONTACT DIMENSIONS SCALE 5:1

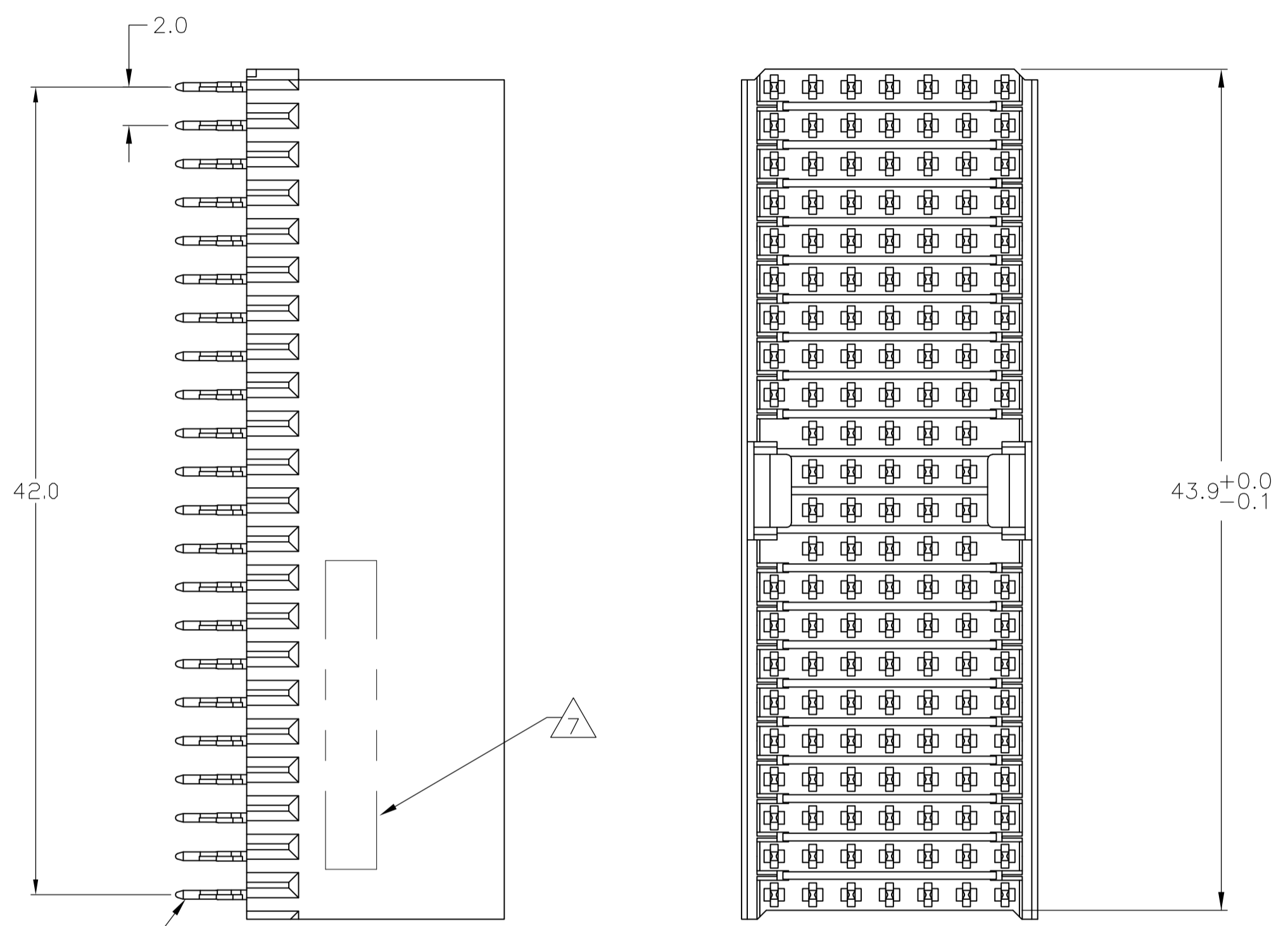
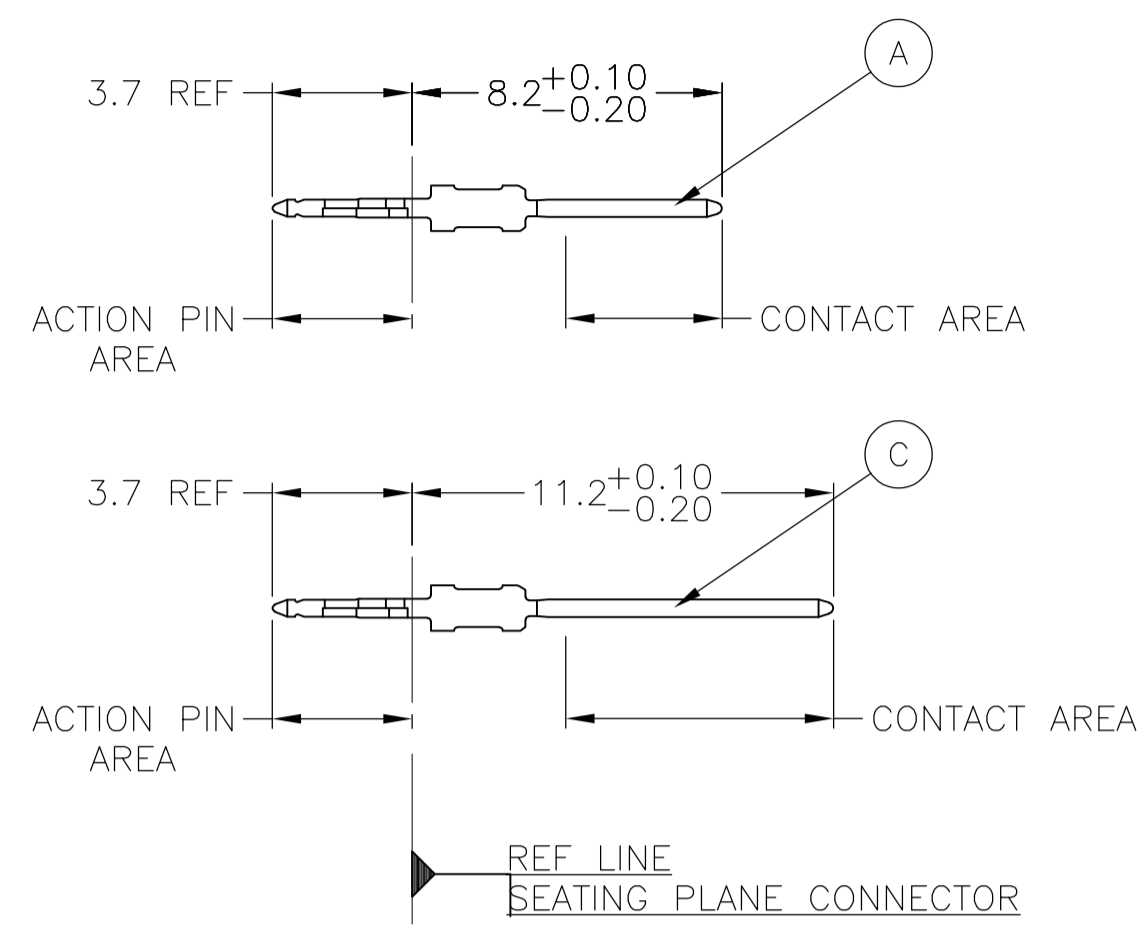

### CONTACT LAYOUT

	z	a	b	c	d	e	f
1	C	A	A	A	A	A	C
2	C	A	A	A	A	A	C
3	C	A	A	A	A	A	C
4	C	A	A	A	A	A	C
5	C	A	A	A	A	A	C
6	C	A	A	A	A	A	C
7	C	A	A	A	A	A	C
8	C	A	A	A	A	A	C
9	C	A	A	A	A	A	C
10		A	A	A	A	A	
11		A	A	A	A	A	
12		A	A	A	A	A	
13		A	A	A	A	A	
14	C	A	A	A	A	A	C
15	C	A	A	A	A	A	C
16	C	A	A	A	A	A	C
17	C	A	A	A	A	A	C
18	C	A	A	A	A	A	C
19	C	A	A	A	A	A	C
20	C	A	A	A	A	A	C
21	C	A	A	A	A	A	C
22	C	A	A	A	A	A	C

### RECOMMENDED PCB-HOLE LAYOUT COMPONENT SIDE SHOWN

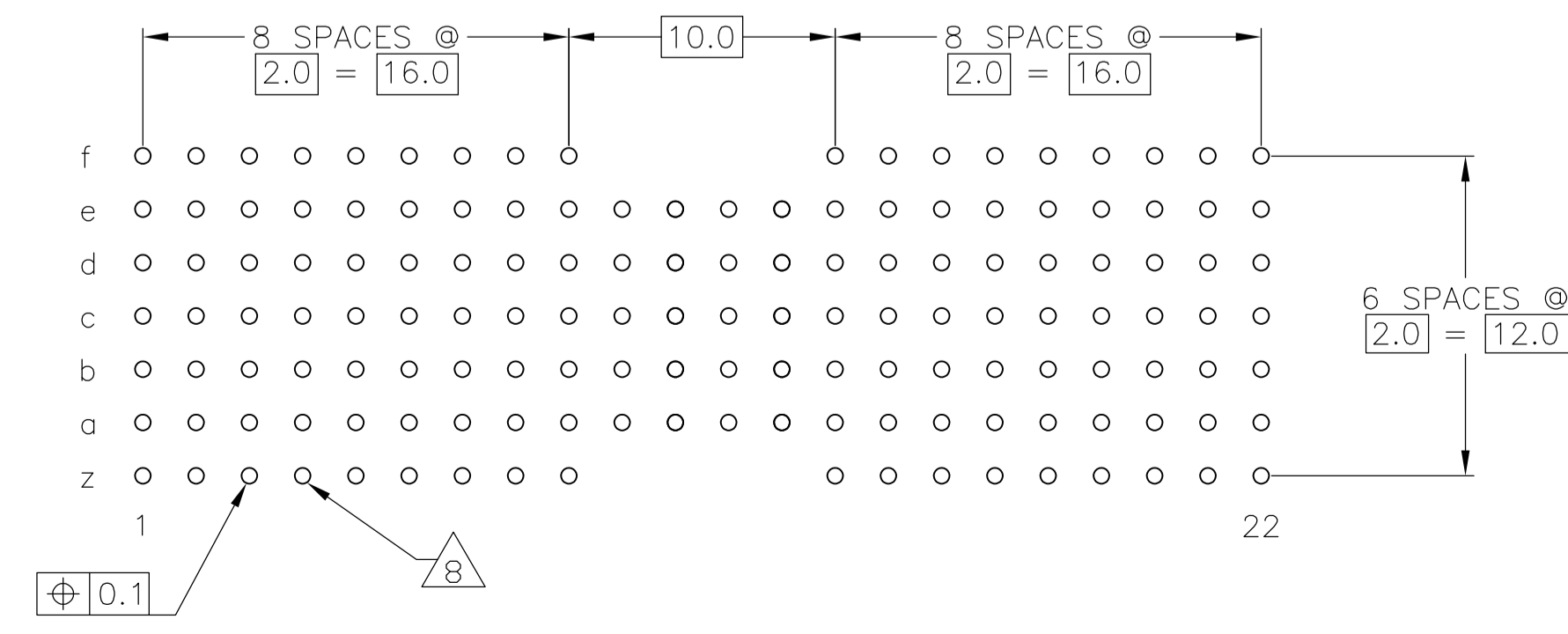

### PLATED THRU HOLES PARAMETERS REFERENCE APPLICATION SPECIFICATION

2	3	13	3-646533-0
2	6	12	1-646533-9
2	5	12	646533-9
2	4		646533-4
2	3		646533-1
OBSOLETE			
FINISH		PART NUMBER	

THIS DRAWING IS A CONTROLLED DOCUMENT.

DIMENSIONS: mm	TOLERANCES UNLESS OTHERWISE SPECIFIED:	DIN B CARBO 29JUL05	G. SKIPPER 29JUL05	Tyco Electronics Corporation Harrisburg, Pa 17105-3608
0-PLC ±	1-PLC ±0.1	APVD G. SKIPPER 29JUL05	NAME	MALE ASSEMBLY, Z-PACK 2mm HM, TYPE A/B
2-PLC ±	3-PLC ±	108-19082	APPLICATION SPEC	114-19029
4-PLC ±	ANGLES	114-19029	SIZE	CAGE CODE
1	SEE TABLE	114-19029	WEIGHT	A1 00779
MATERIAL		FINISH		RESTRICTED TO
1		SEE TABLE		114-19029
CUSTOMER DRAWING		SCALE 4:1		SHEET 1 OF 2

LOC		DIST		REVISIONS			
#	CHR	DESCRIPTION	DATE	DWN	APVD		
AD	00	SEE SHEET 1	-	-	-		

- 1 MATERIAL:  
CONTACT: PHOSPHOR BRONZE.  
HOUSING: GLASS-FILLED POLYESTER.
- 2 GENERAL PLATING SPECIFICATION: UNDERPLATING  
(ENTIRE CONTACT): 1.27µm MIN NICKEL AND ACTION  
PIN: 0.5µm MIN TIN/LEAD.  
FOR PLATING OF MATING SURFACES SEE APPLICABLE  
SPECIFICATION REFERENCE FOR EACH DASH NUMBER.
- 3 CONFORMS TO ALL TESTING ACCORDING TO IEC 61076-4-101  
PERFORMANCE LEVEL 2.
- 4 CONFORMS TO ALL TESTING ACCORDING TO IEC 61076-4-101  
PERFORMANCE LEVEL 1.
- 5 CONNECTOR TESTED AND QUALIFIED AGAINST TELCORDIA GR-1217-CORE QUALITY LEVEL 3,  
CENTRAL OFFICE APPLICATIONS.
- 6 CONNECTOR TESTED AND QUALIFIED AGAINST TELCORDIA GR-1217-CORE QUALITY LEVEL 3,  
UNCONTROLLED ENVIROMENT APPLICATIONS.
- 7 CONNECTOR MARKED WITH PART NUMBER AND DATE CODE.  
ADDITIONAL CHARACTERS OR MARKINGS, AS WELL AS THE LOCATION OF THE MARKINGS,  
MAY BE ADDED FOR TRACEABILITY BASED UPON MANUFACTURERS DISCRETION.
- 8 PLATED-THROUGH HOLES AT 2x2mm SQUARE GRID  
PATTERN DEFINED BY CONTACT LAYOUT.
- 9 FOR ACTUAL PIN LOADING SEE "CONTACT LAYOUT".
- 10 FOR ACTUAL PIN DIMENSIONS SEE "CONTACT DIMENSIONS".
- 11 TO BE MEASURED AT BOTTOM OF SHROUD.
- 12 CONNECTOR LUBRICATED WITH BELCORE APPROVED LUBRICANT,  
TECHNICAL REFERENCE: TR-NWT-001217 ISSUE 1, SEP 1992.
- 13 0.76µm MIN GOLD PLATING AT MATING SURFACES.

THIS DRAWING IS A CONTROLLED DOCUMENT.		DWN E CARBO 29JUL05	Tyco Electronics Corporation Harrisburg, Pa 17105-3608	
DIMENSIONS: mm		CHK G SKIPPER 29JUL05	NAME MALE ASSEMBLY, Z-PACK 2mm HM, TYPE A/B	
TOLERANCES UNLESS OTHERWISE SPECIFIED:		APVD G SKIPPER 29JUL05	RESTRICTED TO	
0-PLG ±		PRODUCT SPEC	SIZE	
1-PLG ± 0.1		108-19082	CAGE CODE	
2-PLG ±		APPLICATION SPEC	DRAWING NO	
3-PLG ±		114-19029	A1 00779	
4-PLG ±		WEIGHT	C=646533	
ANGLES ±		—	—	
MATERIAL SEE SHEET 1	FINISH SEE SHEET 1	CUSTOMER DRAWING		SCALE 4:1
		SHEET 2 OF 2		REV D

## X-ON Electronics

Largest Supplier of Electrical and Electronic Components

*Click to view similar products for [Hard Metric Connectors](#) category:*

*Click to view products by [TE Connectivity](#) manufacturer:*

Other Similar products are found below :

[10146110-VR5C](#) [6345127-1](#) [646916-9](#) [853016](#) [973108](#) [1-2000676-2](#) [1-2000713-0](#) [1-2000713-2](#) [1-2000713-3](#) [134187](#) [1645343-1](#) [1645456-1](#) [1645601-1](#) [1934822-1](#) [223085-1](#) [278071110010833](#) [1645245-1](#) [1645525-1](#) [1645570-1](#) [1645596-1](#) [1857470-1](#) [1934275-1](#) [1934289-1](#) [1934759-1](#) [2000673-1](#) [204975](#) [2170292-2](#) [2-536642-6](#) [3-100668-0](#) [352188-1](#) [352629-1](#) [3-646346-0](#) [3-646457-0](#) [3-646529-0](#) [5120823-1](#) [5120899-1](#) [3-100145-0](#) [3-100147-0](#) [3-100669-1](#) [HM2DK2368PLF](#) [5646530-1](#) [3-352049-0](#) [3-352069-0](#) [3-352115-0](#) [3-352638-0](#) [352189-1](#) [3-646357-0](#) [3-646487-0](#) [3-646513-0](#) [51208191](#)