

LOC		DIST		REVISIONS			
CM	00	F	LTR	DESCRIPTION	DATE	DWN	APVD
		F		REVISED PER ECR-20-000808	26MAY2020	PC	SW

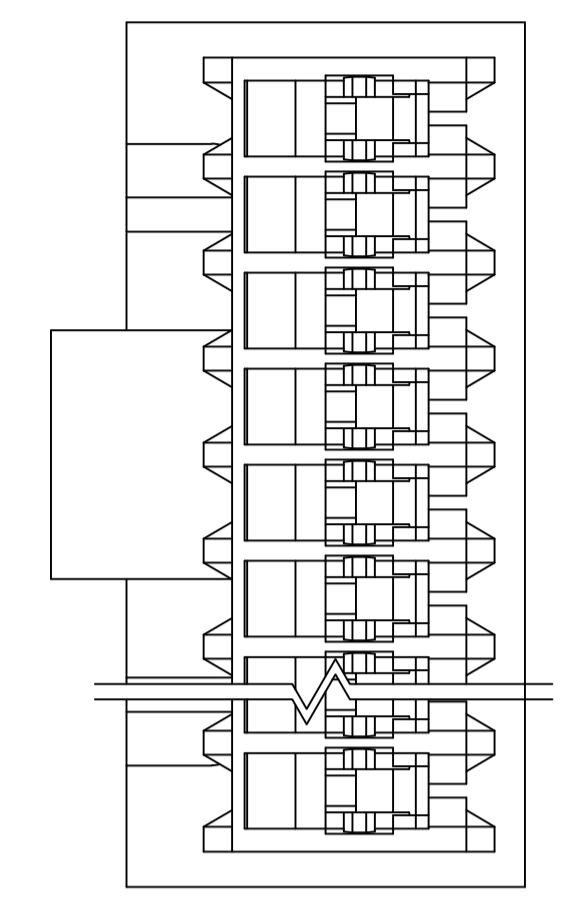

- 1 MATERIAL:
HOUSING- NYLON UL94V-2 (GREEN).
CONTACTS- 0.30 [.012] THK COPPER ALLOY
PLATING : BRIGHT TIN-LEAD FOR 0.00203[.000080] MIN THK FOR 647003-2 THRU 1-647003-9 OR MATTE TIN 0.00203[.000080] MIN THK. FOR 3-647003-2 THRU 4-647003-9,
- 2 CONTACTS ACCEPT 28 AWG (0.08 - 0.09 mm²) TIN PLATED SOLID, CONCENTRIC FUSED STRANDED, OR CONCENTRIC STRANDED (7 STRANDS) WIRE WITH 1.52 [.060] MAX INSULATION DIAMETER.
- 3 MATES WITH STANDARD MTA-100 CONNECTORS: OF THE SAME CIRCUIT SIZES WITH SIMILARLY PLATED CONTACTS WITH POLARIZING TABS-CIRCUIT SIZES 4-19 ONLY WITHOUT POLARIZING TABS-CIRCUIT SIZES 2 & 3.

DOES NOT MATE WITH MTA-100 CONNECTORS: WITH POLARIZING TABS-CIRCUIT SIZES 2 & 3 ONLY. (SEE DETAIL A) WITH BLOCKED CIRCUITS -ALL CIRCUIT SIZES. NOT RECOMMENDED FOR MATING WITH MTA-100 CONNECTOR WITHOUT POLARIZING TABS. CIRCUIT SIZES 4-19.
- 4 ACCESSORIES:
REPLACEMENT IDC CONTACTS: 647033-1.
COVERS: SEE TABLE
- 5 QUANTITY OF CENTRALLY POSITIONED RAILS VARIES WITH CIRCUIT SIZE. (SEE TABLE) LOCATION MAY DIFFER FROM EXAMPLE SHOWN.
- 6 DIMENSIONS IN BRACKETS ARE IN INCHES.
- 7 SIMILAR SIZED LOCK AND SINGLE TAB USED OR CIRCUITS 4 & 5.
- 8 QUANTITY OF GUSSET RIBS VARIES WITH CIRCUIT SIZE (SEE TABLE). LOCATION MAY DIFFER FROM EXAMPLE SHOWN.
- 9 INNER END RAIL PAIR NOT PRESENT FOR CIRCUIT SIZES 2 OR 3.
- 10 CIRCUIT ID MAY APPEAR FULLY NUMBERED OR SHOWING LOCATION 1 ONLY DEPENDING ON CIRCUIT SIZE.
- 11 OBSOLETE PARTS: OBSOLETE CIS STREAMLINING PER D.RENAUD/D.SINISI
- 12 OBSOLETE PARTS

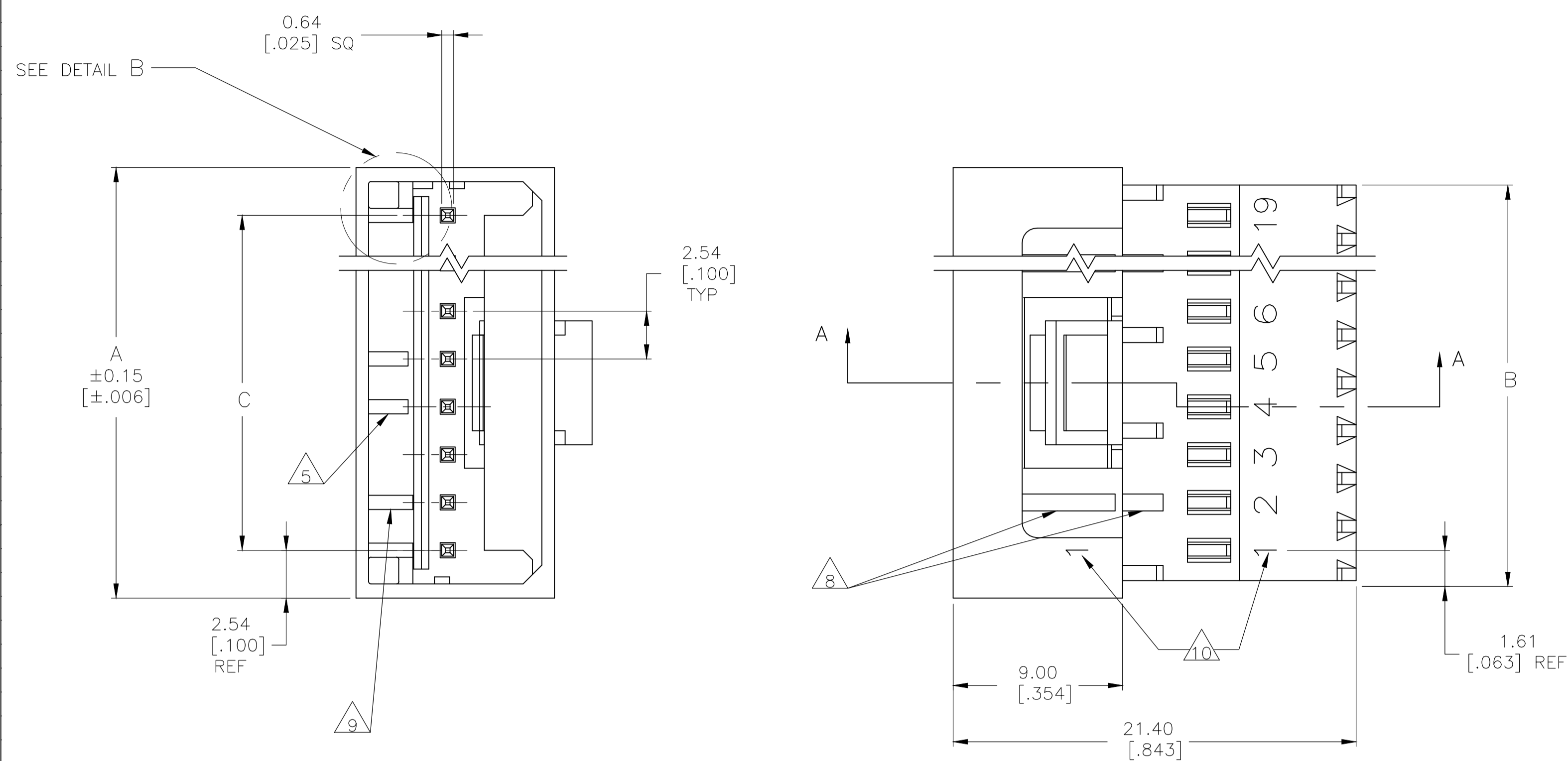
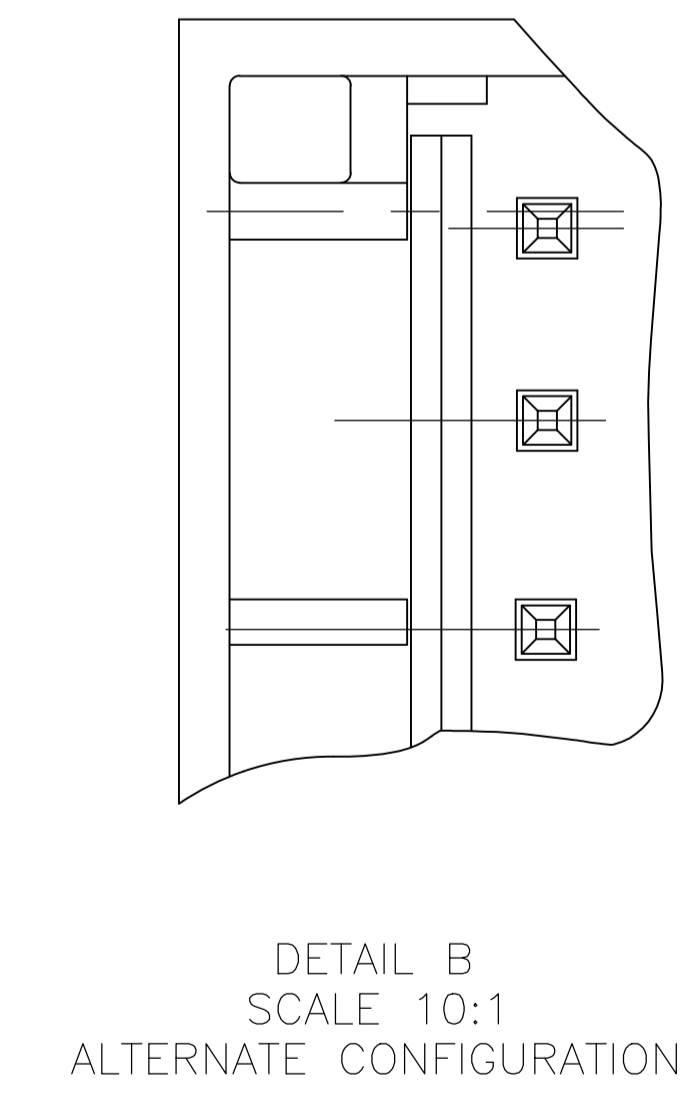
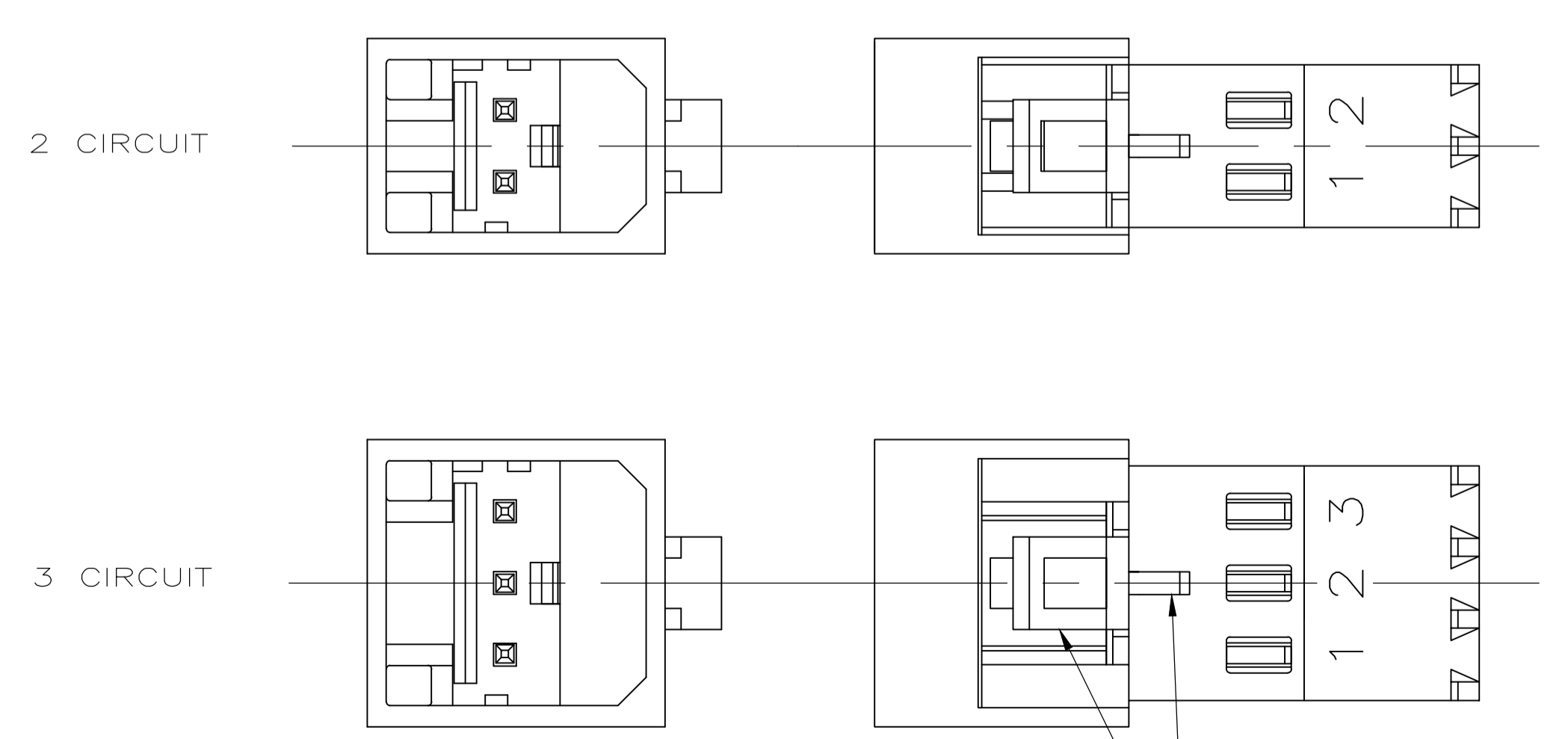
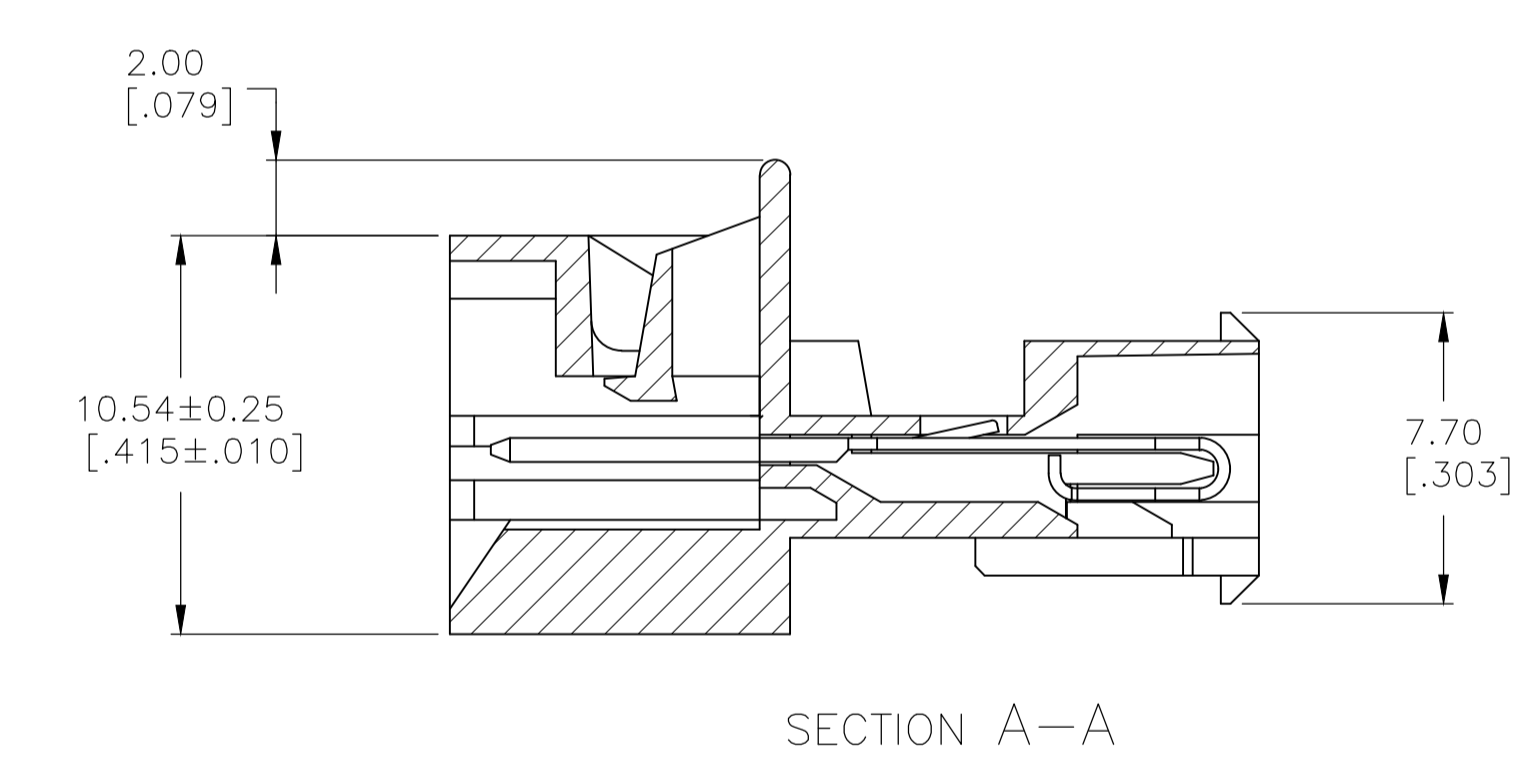

THIS DRAWING IS A CONTROLLED DOCUMENT.		DIN R. LEWIS 29--98	TE Connectivity
DIMENSIONS: mm [INCHES]		CIK R. SWING 29--98	
TOLERANCES UNLESS OTHERWISE SPECIFIED:		APVD J. ELLIS 29--98	NAME
0 PLC ± -	1 PLC ± -	MTA-100 POSTED CONNECTOR ASSEMBLY, CLOSED END, 28 AWG	
2 PLC ± 0.20 [.007]	3 PLC ± -	PRODUCT SPEC	
4 PLC ± -	ANGLES ± -	APPLICATION SPEC	
MATERIAL 1	FINISH 1	SIZE	RESTRICTED TO
		A1	
		WEIGHT	
		A100779	
		C=647003	
		CUSTOMER DRAWING	
		SCALE 5:1	
		SHEET 1 OF 2	
		REV F	

QTY OF GUSSET RIBS	QTY OF CENTRAL RAILS	MM	IN	MM	IN	MM	IN	NO. OF CIRCUITS	PART NO		
4	2	45.72	1.800	48.95	1.927	50.80	2.000	19	4-647003-9		
4	2	43.18	1.700	46.41	1.827	48.26	1.900	18	4-647003-8		
4	2	40.64	1.600	43.86	1.727	45.72	1.800	17	4-647003-7		
4	2	38.10	1.500	41.32	1.627	43.18	1.700	16	4-647003-6		
4	2	35.56	1.400	38.78	1.527	40.64	1.600	15	4-647003-5		
4	2	33.02	1.300	36.24	1.427	38.10	1.500	14	4-647003-4		
4	2	30.48	1.200	33.70	1.327	35.56	1.400	13	4-647003-3		
2	1	27.94	1.100	31.16	1.227	33.02	1.300	12	4-647003-2		
2	1	25.40	1.000	28.62	1.127	30.48	1.200	11	4-647003-1		
2	1	22.86	.900	26.08	1.027	27.94	1.100	10	4-647003-0		
2	1	20.32	.800	23.54	.927	25.40	1.000	9	3-647003-9		
2	0	17.78	.700	21.00	.827	22.86	.900	8	3-647003-8		
0	0	15.24	.600	18.46	.727	20.32	.800	7	3-647003-7		
0	0	12.70	.500	15.92	.627	17.78	.700	6	3-647003-6		
0	0	10.16	.400	13.38	.527	15.24	.600	5	3-647003-5		
0	0	7.62	.300	10.84	.427	12.70	.500	4	3-647003-4		
0	0	5.08	.200	8.30	.327	10.16	.400	3	3-647003-3		
0	0	2.54	.100	5.76	.227	7.62	.300	2	3-647003-2		
4	2	45.72	1.800	48.95	1.927	50.80	2.000	19	4-647003-9		
4	2	43.18	1.700	46.41	1.827	48.26	1.900	18	4-647003-8		
4	2	40.64	1.600	43.86	1.727	45.72	1.800	17	4-647003-7		
4	2	38.10	1.500	41.32	1.627	43.18	1.700	16	4-647003-6		
4	2	35.56	1.400	38.78	1.527	40.64	1.600	15	4-647003-5		
4	2	33.02	1.300	36.24	1.427	38.10	1.500	14	4-647003-4		
4	2	30.48	1.200	33.70	1.327	35.56	1.400	13	4-647003-3		
2	1	27.94	1.100	31.16	1.227	33.02	1.300	12	4-647003-2		
2	1	25.40	1.000	28.62	1.127	30.48	1.200	11	4-647003-1		
2	1	22.86	.900	26.08	1.027	27.94	1.100	10	4-647003-0		
2	1	20.32	.800	23.54	.927	25.40	1.000	9	4-647003-9		
2	0	17.78	.700	21.00	.827	22.86	.900	8	4-647003-8		
0	0	15.24	.600	18.46	.727	20.32	.800	7	4-647003-7		
0	0	12.70	.500	15.92	.627	17.78	.700	6	4-647003-6		
0	0	10.16	.400	13.38	.527	15.24	.600	5	4-647003-5		
0	0	7.62	.300	10.84	.427	12.70	.500	4	4-647003-4		
0	0	5.08	.200	8.30	.327	10.16	.400	3	4-647003-3		
0	0	2.54	.100	5.76	.227	7.62	.300	2	4-647003-2		
DUST COVER	STRAIN RELIEF COVERS	MM		IN		MM		IN		NO. OF CIRCUITS	PART NO
4	ACCESSORIES	8		5		C		B		A	

SUPERCEDED

 SUPERCEDED

 SUPERCEDED

 OBSOLETE

 SUPERCEDED

THIS DRAWING IS A CONTROLLED DOCUMENT.

DIN B. LEWIS 29--98	TE Connectivity MTA-100 POSTED CONNECTOR ASSEMBLY, CLOSED END, 28 AWG
CIK R. SWING 29--98	
APVD J. ELLIS 29--98	NAME
PRODUCT SPEC	APPLICATION SPEC
SIZE	CAGE CODE
DRAWING NO	RESTRICTED TO
WEIGHT	A1 00779 C=647003
CUSTOMER DRAWING	SCALE 1:1 SHEET 2 OF 2 REV F

X-ON Electronics

Largest Supplier of Electrical and Electronic Components

Click to view similar products for [Headers & Wire Housings](#) category:

Click to view products by [TE Connectivity](#) manufacturer:

Other Similar products are found below :

[892-18-020-10-001101](#) [58102-G61-06LF](#) [582553-1](#) [0009485154](#) [009176003701906](#) [0050291907](#) [LY20-4P-DT1-P1E-BR](#) [02.125.8002.8](#)
[609-3404](#) [61062-3](#) [61082-181009](#) [622-3653LF](#) [63453-116](#) [636-1030](#) [636-1427](#) [636-3427](#) [636-4007](#) [641938-9](#) [641991-4](#) [644827-2](#) [65817-010LF](#) [65817-015LF](#) [65863-015LF](#) [66207-023LF](#) [67095-007LF](#) [67601157](#) [68645-018](#) [68648-049](#) [70.362.1628.0](#) [70-4210](#) [70-4226B](#) [70-4853B](#) [707-5020](#) [707-5028](#) [71.350.2428.0](#) [71918-208LF](#) [71961-016LF](#) [733-134](#) [733-162](#) [754199-000](#) [760-3052](#) [787-8014-00](#) [79531-3000](#)
[FCN-360C032-B](#) [FCN-367T-T012/H](#) [FCN-723D010/2](#) [80.063.4001.1](#) [800-90-001-10-001000](#) [800-90-010-10-002000](#) [801-43-002-10-013000](#)