

THIS DRAWING IS UNPUBLISHED. RELEASED FOR PUBLICATION  
 © COPYRIGHT - By - ALL RIGHTS RESERVED.

REVISIONS					
P	LTR	DESCRIPTION	DATE	DWN	APVD
AV		REVISED PER ECO-12-012316	05JUL12	KH	MZ
AW		REVISED PER ECO-17-009977	12JUL2017	RS	MZ

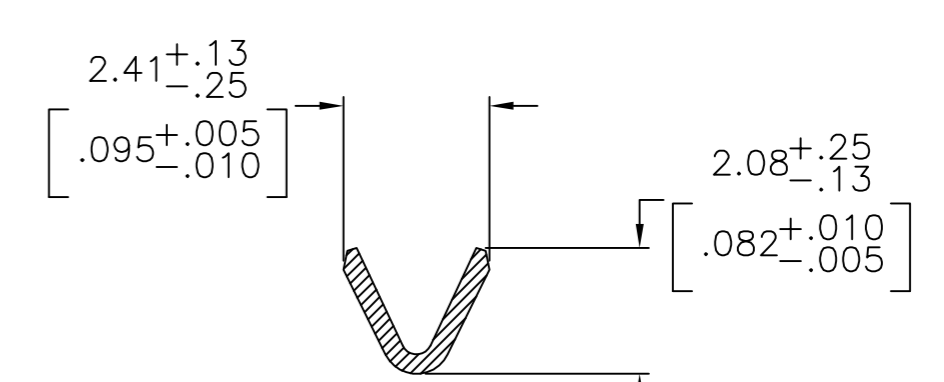
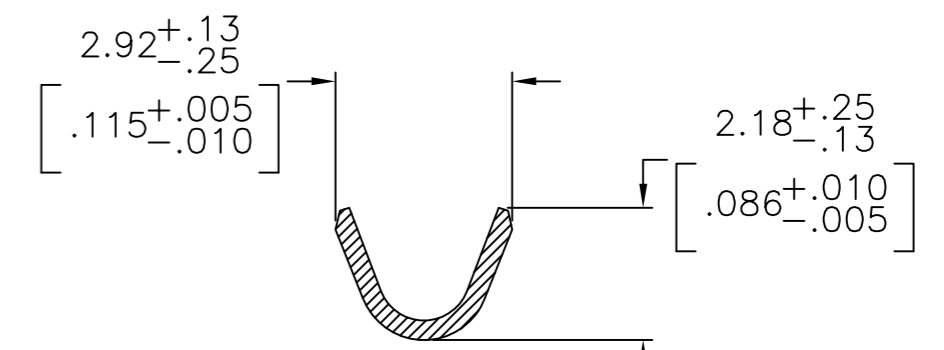
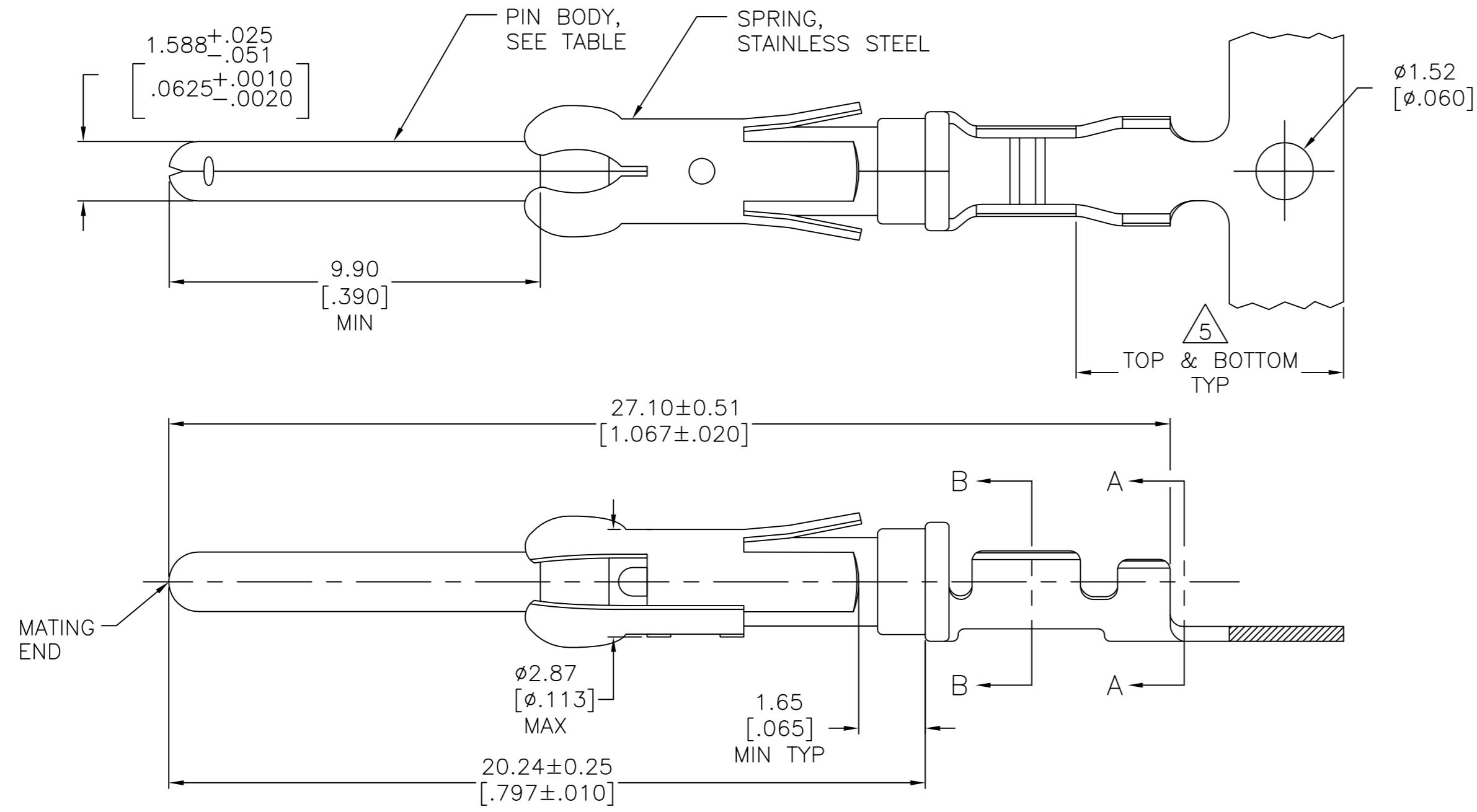

- 1 REVERSE REELED FOR MINI-APPLICATOR.
- 2  $0.76\mu\text{m}$  [.000030] MIN PRECIOUS METAL PLATE ON MATING END FOR A LENGTH OF 5.08 [.200] MIN WITH  $1.27\mu\text{m}$  [.000050] MIN MATTE TIN PLATE IN WIRE CRIMP AREA, BOTH OVER  $1.27\mu\text{m}$  [.000050] MIN NICKEL PLATE. CONFORMS TO THE REQUIREMENTS OF TE CONNECTIVITY PRODUCT SPEC 108-10042, BASED ON EIA/ECA-364-1000.01 ( CONTROLLED ENVIRONMENT APPLICATIONS ),
- 3  $0.76\mu\text{m}$  [.000030] MIN PRECIOUS METAL PLATE ON MATING END FOR A LENGTH OF 5.08 [.200] MIN WITH A UNIFORM GRADIENT TO  $0.25\mu\text{m}$  [.000010] MIN ON REMAINDER, OVER  $1.27\mu\text{m}$  [.000050] MIN NICKEL PLATE. GOLD FLASH ALL OVER. CONFORMS TO THE REQUIREMENTS OF TE CONNECTIVITY PRODUCT SPEC 108-10042, BASED ON EIA/ECA-364-1000.01 ( CONTROLLED ENVIRONMENT APPLICATIONS ).
- 4  $0.38\mu\text{m}$  [.000015] MIN GOLD PER MIL-G-45204 ON MATING END FOR A LENGTH OF 5.08 [.200] MIN WITH  $1.27\mu\text{m}$  [.000050] MIN MATTE TIN PLATE IN WIRE CRIMP AREA, BOTH OVER  $1.27\mu\text{m}$  [.000050] MIN NICKEL PER QQ-N-290.
- 5 GOLD PLATING NEED NOT APPEAR IN THIS AREA.
- 6  $1.27\mu\text{m}$  [.000050] MIN GOLD PER MIL-G-45204 ON MATING END FOR A LENGTH OF 5.08 [.200] MIN WITH GOLD FLASH ON THE REMAINDER OVER  $1.90\mu\text{m}$  [.000075] MIN NICKEL PER QQ-N-290.
- 7  $1.27\mu\text{m}$  [.000050] MIN TIN-LEAD PER MIL-T-10727 OVER  $1.27\mu\text{m}$  [.000050] MIN NICKEL PER QQ-N-290.
- 8 WIRE RANGE 24-20 AWG.
- 9 INSULATION RANGE 1.02[.040]-2.03[.080] DIA.
- 10  $0.38\mu\text{m}$  [.000015] MIN GOLD PER MIL-G-45204 ON MATING END FOR A LENGTH OF 5.08 [.200] MIN,  $1.27\mu\text{m}$  [.000050] MIN TIN-LEAD PER MIL-T-10727 FOR A LENGTH OF 5.69 [.224] MIN ON OPPOSITE END, BOTH OVER  $1.27\mu\text{m}$  [.000050] MIN NICKEL PER QQ-N-290 ON ENTIRE CONTACT.
- 11  $1.27\mu\text{m}$  [.000050] MIN TIN PER MIL-T-10727 OVER  $1.27\mu\text{m}$  [.000050] MIN NICKEL PER QQ-N-290.
- 12  $0.38\mu\text{m}$  [.000015] MIN GOLD PER MIL-G-45204 ON MATING END FOR A LENGTH OF 5.08 [.200] MIN,  $1.27\mu\text{m}$  [.000050] MIN TIN FOR A LENGTH OF 5.69 [.224] MIN ON OPPOSITE END, BOTH OVER  $1.27\mu\text{m}$  [.000050] MIN NICKEL PER QQ-N-290 ON ENTIRE CONTACT.
- 13  $2.54\mu\text{m}$  [.000100] MIN SILVER OVER  $0.76\mu\text{m}$  [.000030] MIN NICKEL PER QQ-N-290
- 14 OBSOLETE PARTS: OBSOLETE CIS STREAMLINING PER D.RENAUD/D.SINISI

14	OBSOLETE	1	13	BRASS	-	2-66102-8
14	OBSOLETE	1	12	BRASS	-	2-66102-7
	STANDARD	1	11	BRASS	1-66103-8	2-66102-6
		1	11	BRASS	1-66103-8	2-66102-5
14	OBSOLETE	1	10	BRASS	1-66103-3	2-66102-3
	OBSOLETE	1	2	PHOSPHOR BRONZE	1-66103-2	2-66102-2
	OBSOLETE	1	7	PHOSPHOR BRONZE	1-66103-1	2-66102-1
	OBSOLETE	1	6	BRASS	1-66103-0	1-66102-7
		1	2	BRASS	66103-4	66102-9
		1	4	BRASS	66103-3	66102-8
		1	7	BRASS	66103-2	66102-7
		1	3	BRASS	66103-1	66102-6
	STANDARD		2	BRASS	66103-4	66102-4
	STANDARD		4	BRASS	66103-3	66102-3
	STANDARD		7	BRASS	66103-2	66102-2
	STANDARD		3	BRASS	66103-1	66102-1
	REELING			PIN BODY FINISH		
				PIN BODY		LOOSE PIECE REF
						PART NO

THIS DRAWING IS A CONTROLLED DOCUMENT.

DWN V. FURLER 11JUL03  
 CHK G. STEINHAUER 11JUL03  
 APVD G. STEINHAUER 11JUL03

TE Connectivity

PIN ASSEMBLY, .062, TYPE III+

SIZE A2 CAGE CODE 00779 DRAWING NO C=66102 RESTRICTED TO -

SCALE 8:1 SHEET 1 of 1 REV AW

MATERIAL SEE CALLOUTS TOLERANCES UNLESS OTHERWISE SPECIFIED: SEE TABLE

0 PLC ± -  
 1 PLC ± -  
 2 PLC ± 0.13[.005]  
 3 PLC ± -  
 4 PLC ± -  
 ANGLES ± -  
 FINISH

PRODUCT SPEC -  
 APPLICATION SPEC -  
 WEIGHT -

CUSTOMER DRAWING

## X-ON Electronics

Largest Supplier of Electrical and Electronic Components

*Click to view similar products for [Standard Circular Contacts](#) category:*

*Click to view products by [TE Connectivity](#) manufacturer:*

Other Similar products are found below :

[RC16M23J](#) [133780-1](#) [RM20M13D28](#) [RM24M9D28](#) [RMMX110-1D28](#) [MS3474W10-6P L/C](#) [ELVP16100E](#) [164-901-CD](#) [EN3545007SCE](#)  
[BV002BSQ20049CZ](#) [BV002SSQ160404CZ](#) [1900ND05S1B00B](#) [166566-1](#) [1900ND04S1X00D](#) [ST-JL05-16S-C3-100](#) [ST-JL05-20S-C1-100](#)  
[ST-JL05-20S-C2-100](#) [T01-CRIMP-S03](#) [APK-SA16A07-002](#) [27963-15T12](#) [CONT-JL05-08S-C2-10](#) [CONT-JL05-12S-C1-10](#) [RC16M-23T](#)  
[RFD26L-1D28](#) [BV002ASJ16049CW](#) [JN1-22-20S-R-PKG100](#) [031-50213](#) [031-50565](#) [031-50794](#) [SJS861301M](#) [ST-JL05-16S-C1-100](#) [ST-](#)  
[JL05-20P-C1-100](#) [82911466K](#) [192991-0087](#) [192900-0570](#) [44-100-1414P-1000-101](#) [T3P16FC3LZ](#) [ST-JL05-16S-C2-3500](#) [ZP-4016-10NF](#)  
[CONT-JL05-12P-C1-10](#) [RM20M12G8D28](#) [031-50676](#) [12115010110](#) [RJFTVC2MG](#) [CAP-DACMDPC2](#) [031-50675-002](#) [CAP-DD1FDPC2](#)  
[CAP-DACMDPC1](#) [031-50966-010](#) [ASSP-10-F-A-C-SA](#)