

THIS DRAWING IS UNPUBLISHED. RELEASED FOR PUBLICATION  
 © COPYRIGHT - By - ALL RIGHTS RESERVED.

REVISIONS					
P	LTR	DESCRIPTION	DATE	DWN	APVD
	AH	REVISED PER ECO-12-012320	04JUL12	KH	MZ
	AJ	REVISED PER ECO-17-009977	11JUL2017	RS	MZ

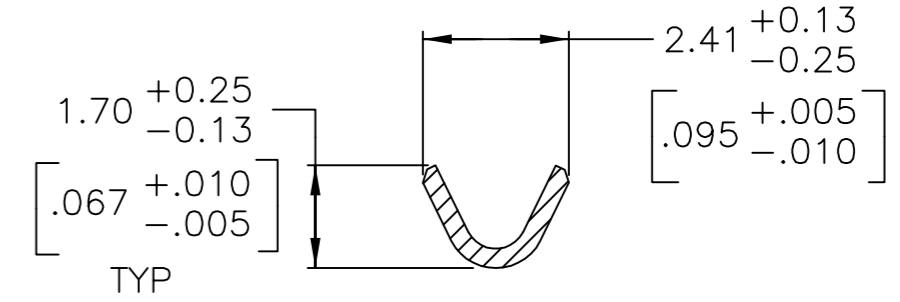

SECTION A-A

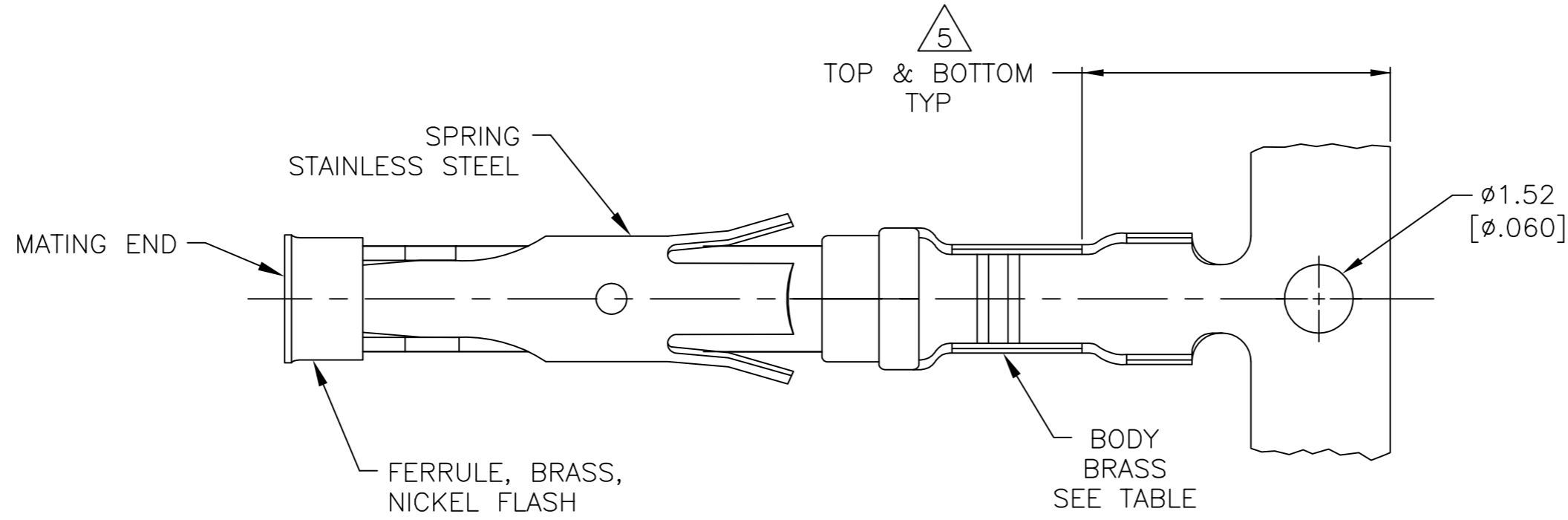
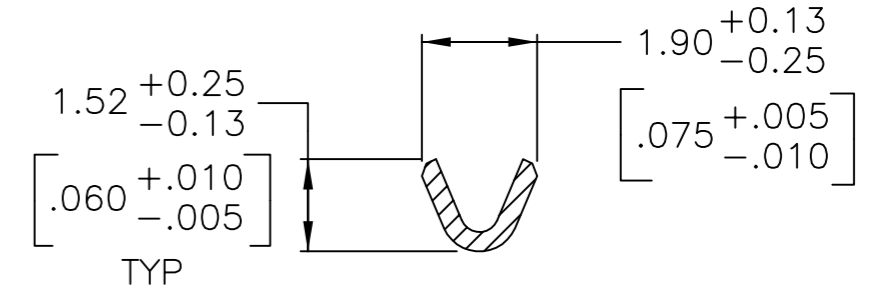
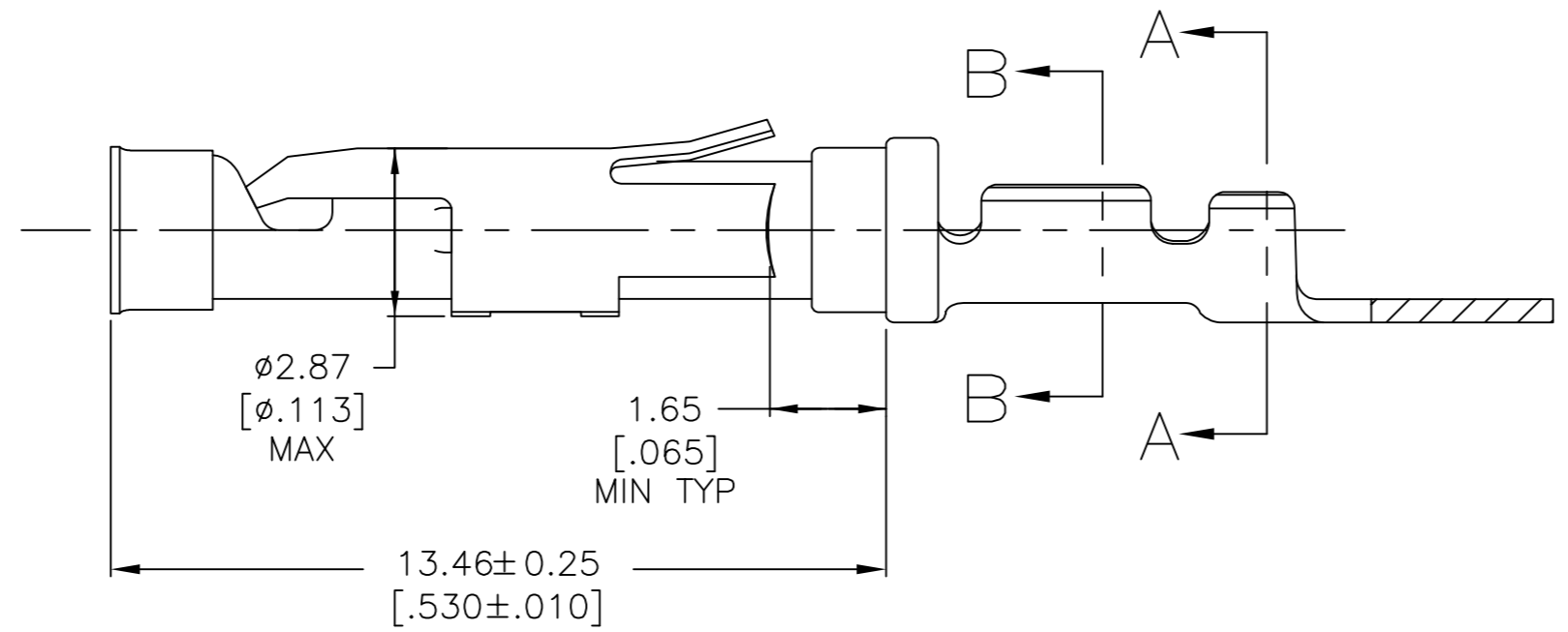
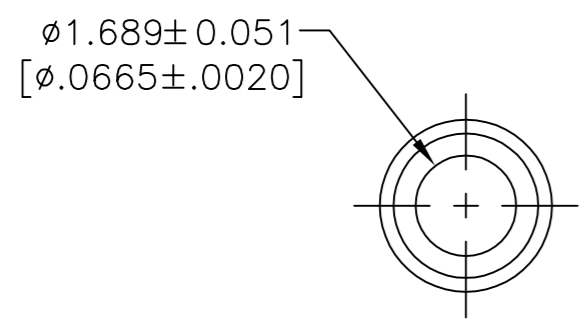

SECTION B-B

- 1 0.76μm [.000030] MIN GOLD PER MIL-G-45204 ON MATING END FOR A LENGTH OF 5.08 [.200] MIN WITH 1.27μm [.000050] MIN MATTE TIN PLATE IN WIRE CRIMP AREA, BOTH OVER 0.76μm [.000030] MIN NICKEL PER QQ-N-290.
- 2 1.27μm [.000050] MIN TIN-LEAD PER MIL-T-10727 OVER 0.76μm [.000030] MIN NICKEL PER QQ-N-290.
- 3 0.76μm [.000030] MIN GOLD PER MIL-G-45204 ON MATING END FOR A LENGTH OF 5.08 [.200] MIN WITH A UNIFORM GRADIENT TO 0.25μm [.000010] MIN GOLD PER MIL-G-45204 ON THE REMAINDER OVER 0.76μm [.000030] MIN NICKEL PER QQ-N-290.
- 4 0.38μm [.000015] MIN GOLD PER MIL-G-45204 ON MATING END FOR A LENGTH OF 5.08 [.200] MIN WITH 1.27μm [.000050] MIN MATTE TIN PLATE IN WIRE CRIMP AREA, BOTH OVER 0.76μm [.000030] MIN NICKEL PER QQ-N-290.
- 5 GOLD PLATING NEED NOT APPEAR IN THIS AREA.
- 6 REVERSE REELED FOR MINI-APPLICATOR.
- 7 WIRE RANGE 26-24 AWG. INSULATION RANGE 0.89 [.035]-1.40 [.055].
- 8 0.38μm [.000015] MIN GOLD PER MIL-G-45204 ON MATING END FOR A LENGTH OF 5.08 [.200] MIN, 1.27μm [.000050] MIN TIN-LEAD PER MIL-T-10727 FOR A LENGTH OF 5.69 [.224] MIN ON OPPOSITE END, BOTH OVER 1.27μm [.000050] MIN NICKEL PER QQ-N-290 ON ENTIRE CONTACT.
- 9 1.27μm [.000050] MIN TIN PER MIL-T-10727 OVER 0.76μm [.000030] MIN NICKEL PER QQ-N-290.
- 10 0.38μm [.000015] MIN GOLD PER MIL-G-45204 ON MATING END FOR A LENGTH OF 5.08 [.200] MIN, 1.27μm [.000050] TIN PER MIL-T-10727 FOR A LENGTH OF 5.69 [.224] MIN ON OPPOSITE END, BOTH OVER 1.27μm [.000050] MIN NICKEL PER QQ-N-290 ON ENTIRE CONTACT.

	STANDARD	9	1-66109-7	1-66108-7
OBSOLETE	6	10	-	1-66108-6
	6	9	1-66109-7	1-66108-5
OBSOLETE	6	8	1-66109-3	1-66108-4
	6	1	66109-4	66108-8
	6	4	66109-3	66108-7
	6	2	66109-2	66108-6
	6	3	66109-1	66108-5
	STANDARD	1	66109-4	66108-4
	STANDARD	4	66109-3	66108-3
	STANDARD	2	66109-2	66108-2
	STANDARD	3	66109-1	66108-1
	REELING	BODY FINISH	LOOSE PIECE REF	PART NO

THIS DRAWING IS A CONTROLLED DOCUMENT.		DWN	R.SHIREY	08/06/91
DIMENSIONS: mm [INCHES]		CHK	R.STONE	9-19-91
TOLERANCES UNLESS OTHERWISE SPECIFIED:		APVD	J.WESTMAN	9-20-81
0 PLC ± -		NAME		
1 PLC ± -		SOCKET ASSEMBLY, .062, TYPE III+		
2 PLC ± 0.13 [.005]		SIZE		
3 PLC ± -		CAGE CODE		
4 PLC ± -		DRAWING NO		
ANGLES ± -		RESTRICTED TO		
FINISH		WEIGHT		
SEE CALLOUTS		A2 00779 C=66108		
MATERIAL		SCALE		
SEE CALLOUTS		8:1		
CUSTOMER DRAWING		SHEET		
		1 of 1		
		REV		
		AJ		

## X-ON Electronics

Largest Supplier of Electrical and Electronic Components

*Click to view similar products for [Standard Circular Contacts](#) category:*

*Click to view products by [TE Connectivity](#) manufacturer:*

Other Similar products are found below :

[RC16M23J](#) [133780-1](#) [RM20M13D28](#) [RMMX110-1D28](#) [ELFH02211](#) [ELVP16100E](#) [164-901-CD](#) [BACS16X1A](#) [EN3545007SCE](#)  
[BV002BSQ20049CZ](#) [BV002SSQ160404CZ](#) [1900ND05S1B00B](#) [SJS862201](#) [166566-1](#) [1900ND04S1X00D](#) [ST-JL05-20S-C1-100](#) [ST-JL05-20S-C2-100](#) [T01-CRIMP-S03](#) [APK-SA16A07-002](#) [27963-15T12](#) [CONT-JL05-08S-C2-10](#) [CONT-JL05-12S-C1-10](#) [RC16M-23T](#) [RFD26L-1D28](#) [BV002ASJ16049CW](#) [33505815019](#) [JN1-22-20S-R-PKG100](#) [031-50213](#) [031-50794](#) [ELFH08251](#) [ELFP0641GE](#) [SJS861301M](#) [ST-JL05-16S-C1-100](#) [ST-JL05-20P-C1-100](#) [82911466K](#) [82911467NK](#) [ESLM03200](#) [192991-0087](#) [192900-0570](#) [ELFH07251](#) [M12883/40-07S](#)  
[BACS16X3A](#) [T3P16FC3LZ](#) [ZP-4016-10NF](#) [CONT-JL05-12P-C1-10](#) [RM20M12G8D28](#) [031-50676](#) [12115010110](#) [RJFTVC2MG](#) [CAP-DACMDPC2](#)