

THIS DRAWING IS UNPUBLISHED. RELEASED FOR PUBLICATION
 © COPYRIGHT - By - ALL RIGHTS RESERVED.

REVISIONS					
P	LTR	DESCRIPTION	DATE	DWN	APVD
Y		REVISED PER ECO-12-012320	04JUL12	KH	MZ
Z		REVISED PER ECO-16-017885	07OCT2017	RS	MZ

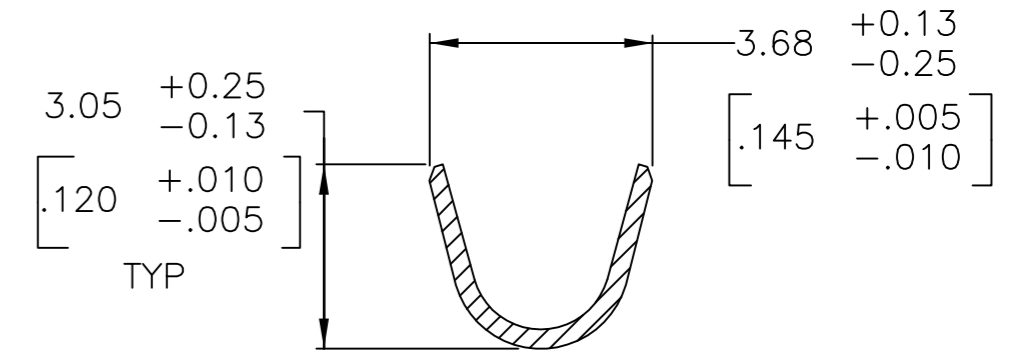

$\phi 1.689 \pm 0.051$
 [$\phi .0665 \pm .0020$]

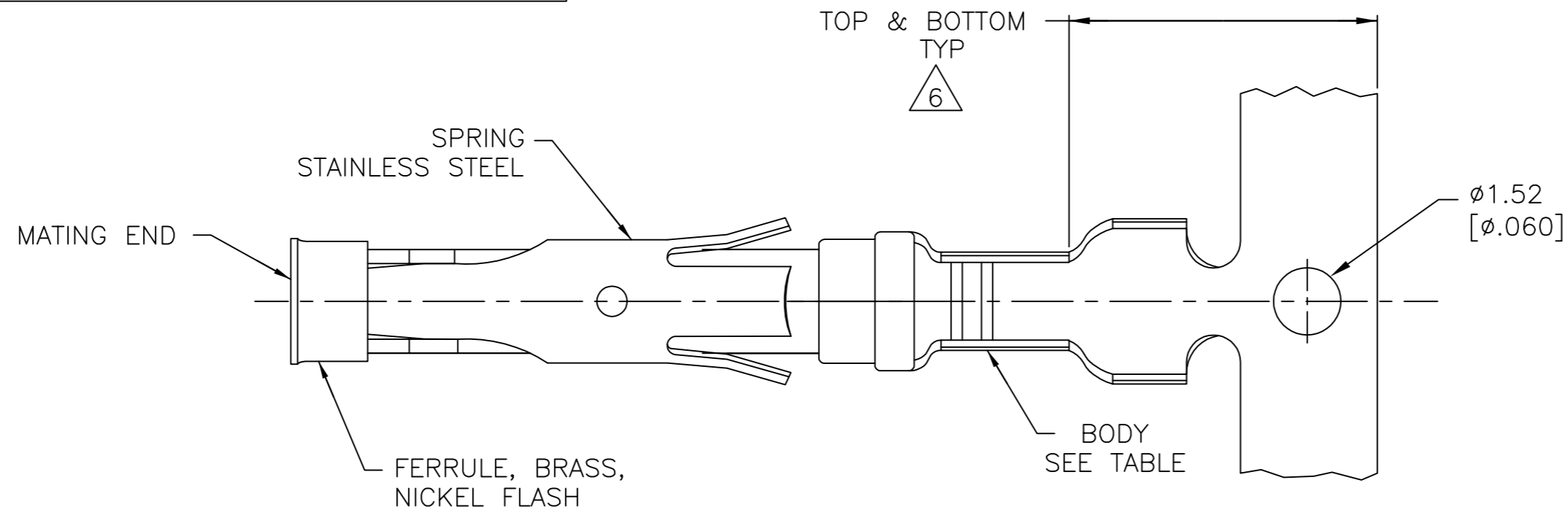
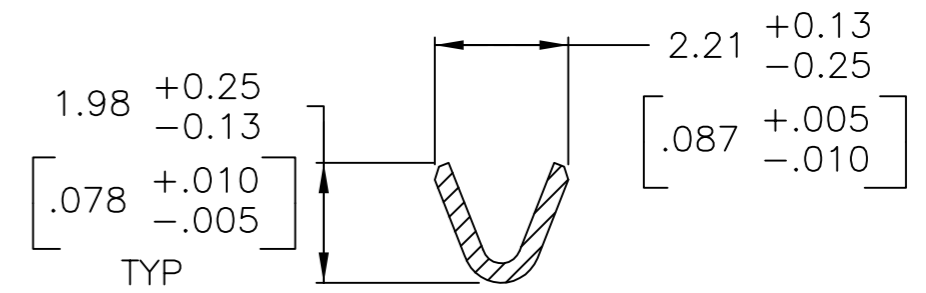
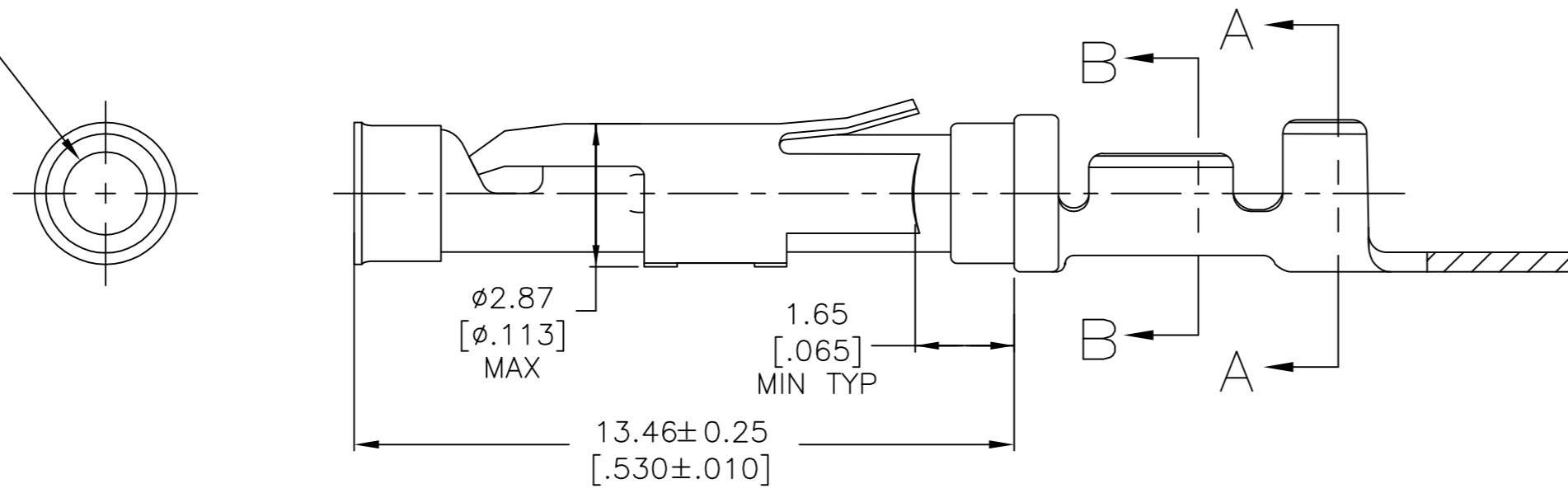

- 1 0.76 μ m [.000030] MIN GOLD PER MIL-G-45204 ON MATING END FOR A LENGTH OF 5.08 [.200] MIN WITH 1.27 μ m [.000050] MIN MATTE TIN PLATE IN WIRE CRIMP AREA, BOTH OVER 0.76 μ m [.000030] MIN NICKEL PER QQ-N-290.
- 2 1.27 μ m [.000050] MIN TIN-LEAD PER MIL-T-10727 OVER 0.76 μ m [.000030] MIN NICKEL PER QQ-N-290.
- 3 0.76 μ m [.000030] MIN GOLD PER MIL-G-45204 ON MATING END FOR A LENGTH OF 5.08 [.200] MIN WITH A UNIFORM GRADIENT TO 0.25 μ m [.000010] MIN GOLD PER MIL-G-45204 ON THE REMAINDER OVER 0.76 μ m [.000030] MIN NICKEL PER QQ-N-290.
- 4 0.38 μ m [.000015] MIN GOLD PER MIL-G-45204 ON MATING END FOR A LENGTH OF 5.08 [.200] MIN WITH 1.27 μ m [.000050] MIN MATTE TIN PLATE IN WIRE CRIMP AREA, BOTH OVER 0.76 μ m [.000030] MIN NICKEL PER QQ-N-290.
- 5 1.27 μ m [.000050] MIN GOLD PER MIL-G-45204 ON MATING END FOR A LENGTH OF 5.08 [.200] MIN WITH GOLD FLASH ON REMAINDER OVER 0.76 μ m [.000030] MIN NICKEL PER QQ-N-290.
- 6 GOLD PLATING NEED NOT APPEAR IN THIS AREA.
- 7 REVERSE REELED FOR MINI-APPLICATOR.
- 8 WIRE RANGE 24-20 AWG. INSULATION RANGE 2.03 [.080]-2.54 [.100].
- 9 NOT RELEASED, AMP HOLLAND USE ONLY
- 10 0.38 μ m [.000015] MIN GOLD PER MIL-G-45204 ON MATING END FOR A LENGTH OF 5.08 [.200] MIN, 1.27 μ m [.000050] MIN TIN-LEAD PER MIL-T-10727 FOR A LENGTH OF 5.69 [.224] MIN ON OPPOSITE END, BOTH OVER 1.27 μ m [.000050] MIN NICKEL PER QQ-N-290 ON ENTIRE CONTACT.
- 11 1.27 μ m [.000050] MIN TIN PER MIL-T-10727 OVER 0.76 μ m [.000030] MIN NICKEL PER QQ-N-290.
- 12 OBSOLETE PARTS: OBSOLETE CIS STREAMLINING PER D.RENAUD/D.SINISI

	STANDARD		BODY MATERIAL	LOOSE PIECE REF	PART NO.
		11	BRASS	1-66399-0	1-66331-5
	7	11	BRASS	1-66399-0	1-66331-4
12	7	1	PHOSPHOR BRONZE	-	1-66331-3
	7	10	BRASS	66399-5	1-66331-2
	7	5	BRASS	-	1-66331-1
	-	-	BRASS	-	9 1-66331-0
	-	-	BRASS	-	9 66331-9
	7	1	BRASS	66399-4	66331-8
	7	4	BRASS	66399-3	66331-7
	7	3	BRASS	66399-2	66331-6
	7	2	BRASS	66399-1	66331-5
	STANDARD	1	BRASS	66399-4	66331-4
	STANDARD	3	BRASS	66399-2	66331-2
	STANDARD	2	BRASS	66399-1	66331-1
	REELING	BODY FINISH	BODY MATERIAL	LOOSE PIECE REF	PART NO.

THIS DRAWING IS A CONTROLLED DOCUMENT.

DWN	R.SHIREY	08/06/91
CHK	R.STONE	9-19-91
APVD	J.WESTMAN	9-20-91

TE Connectivity

SOCKET ASSEMBLY, .062, TYPE III+

SIZE	A2	CAGE CODE	00779	DRAWING NO	C=66331	RESTRICTED TO	-
SCALE	8:1	SHEET	1 of 1	REV	Z		

CUSTOMER DRAWING

X-ON Electronics

Largest Supplier of Electrical and Electronic Components

Click to view similar products for [Standard Circular Contacts](#) category:

Click to view products by [TE Connectivity](#) manufacturer:

Other Similar products are found below :

[RC16M23J](#) [133780-1](#) [RM20M13D28](#) [RM24M9D28](#) [RMMX110-1D28](#) [MS3474W10-6P L/C](#) [ELVP16100E](#) [164-901-CD](#) [EN3545007SCE](#)
[BV002BSQ20049CZ](#) [BV002SSQ160404CZ](#) [1900ND05S1B00B](#) [SJS862201](#) [166566-1](#) [1900ND04S1X00D](#) [ST-JL05-16S-C3-100](#) [ST-JL05-20S-C1-100](#) [ST-JL05-20S-C2-100](#) [T01-CRIMP-S03](#) [APK-SA16A07-002](#) [27963-15T12](#) [CONT-JL05-08S-C2-10](#) [CONT-JL05-12S-C1-10](#)
[RC16M-23T](#) [RFD26L-1D28](#) [BV002ASJ16049CW](#) [JN1-22-20S-R-PKG100](#) [031-50213](#) [031-50565](#) [031-50794](#) [SJS861301M](#) [ST-JL05-16S-C1-100](#) [ST-JL05-20P-C1-100](#) [82911466K](#) [82911467NK](#) [192991-0087](#) [192900-0570](#) [44-100-1414P-1000-101](#) [T3P16FC3LZ](#) [ST-JL05-16S-C2-3500](#) [ZP-4016-10NF](#) [CONT-JL05-12P-C1-10](#) [RM20M12G8D28](#) [031-50676](#) [12115010110](#) [RJFTVC2MG](#) [CAP-DACMDPC2](#) [031-50675-002](#) [CAP-DD1FDPC2](#) [CAP-DACMDPC1](#)