

THIS DRAWING IS UNPUBLISHED. RELEASED FOR PUBLICATION  
 © COPYRIGHT - By - ALL RIGHTS RESERVED.

REVISIONS					
P	LTR	DESCRIPTION	DATE	DWN	APVD
Y		REVISED PER ECO-12-012320	04JUL12	KH	MZ
Z		REVISED PER ECO-17-009977	12JUL2017	RS	MZ

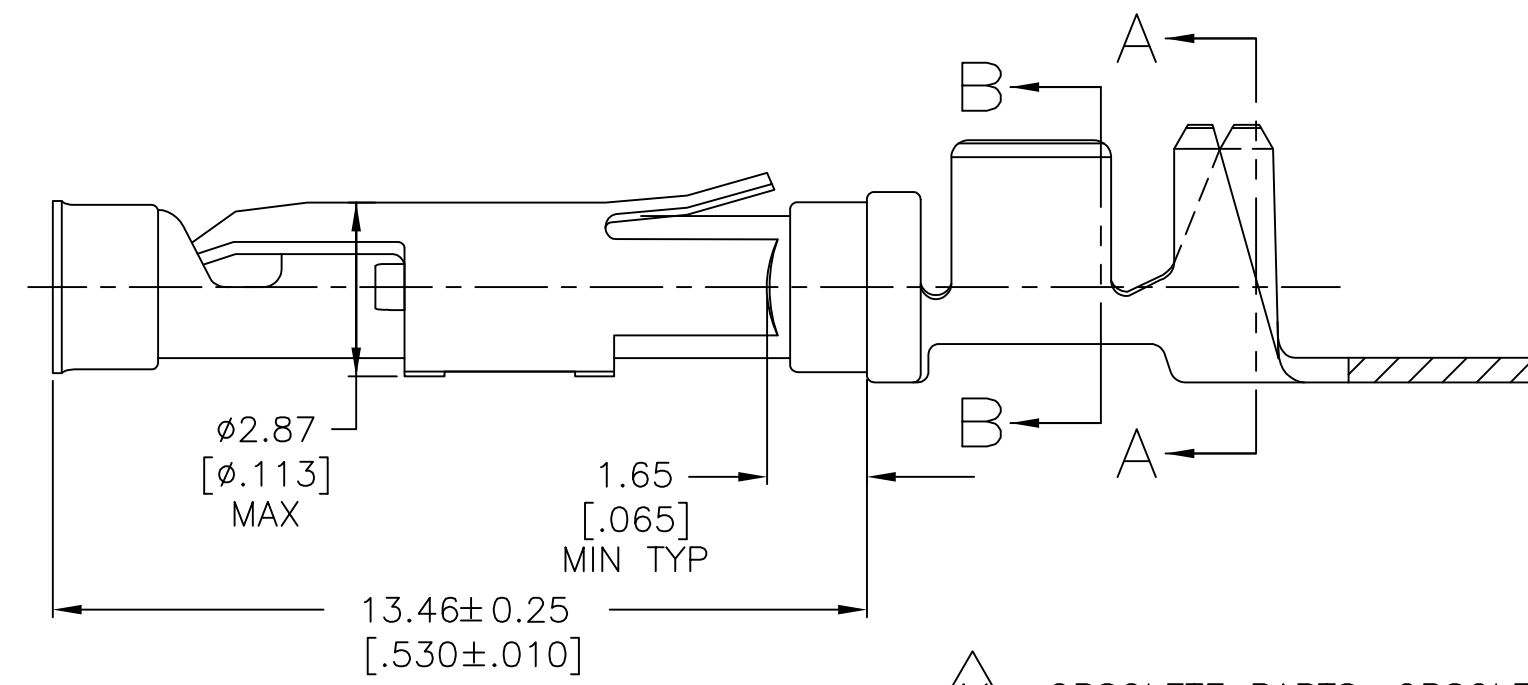
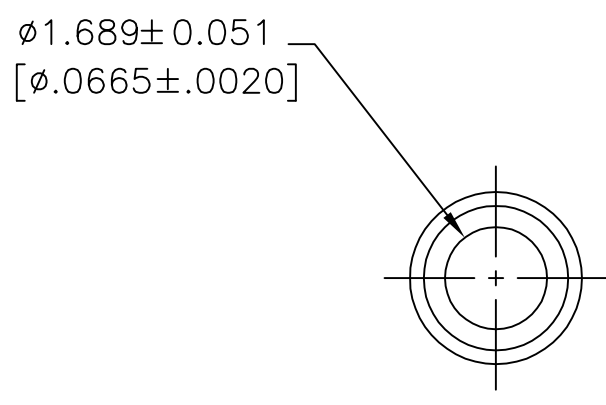
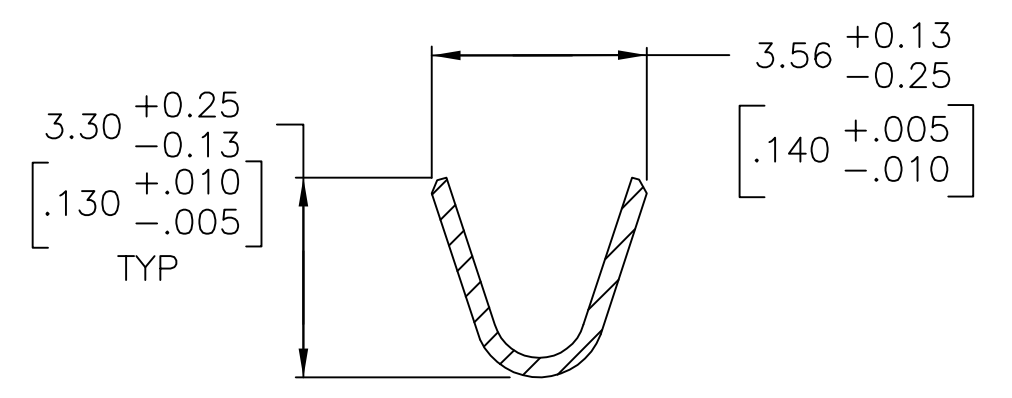
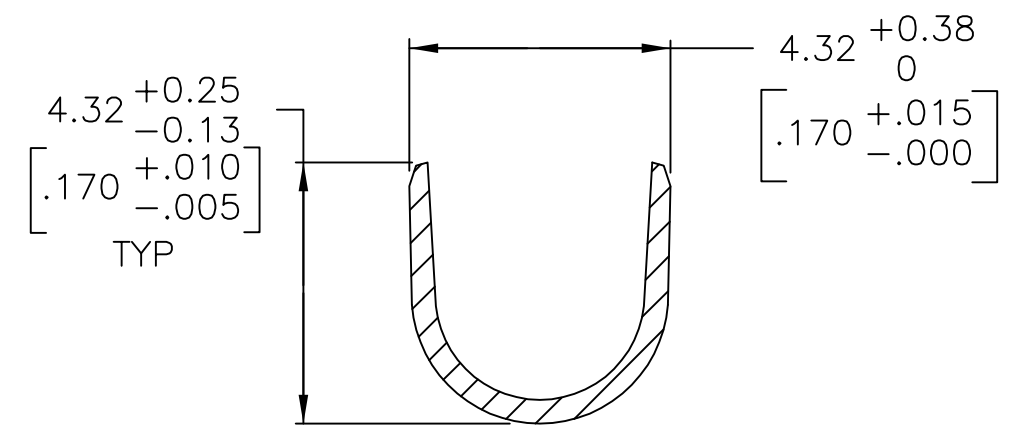
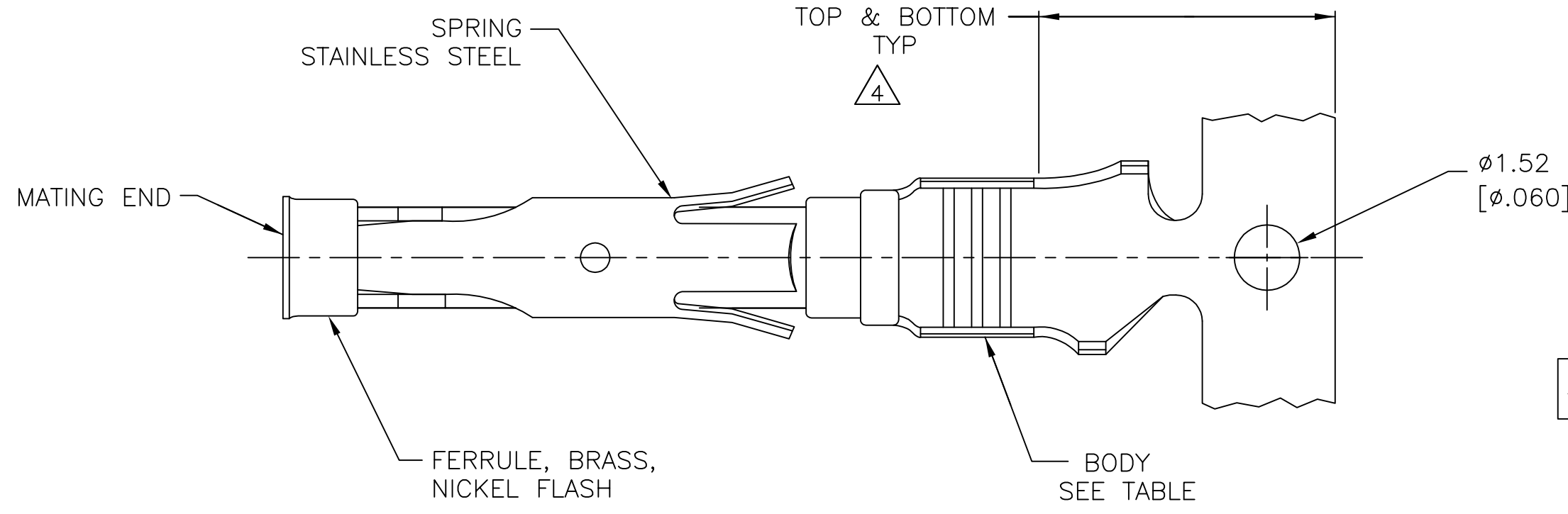

- 1 0.51μm [.000020] MIN GOLD PER MIL-G-45204 ON MATING END FOR A LENGTH OF 5.08 [.200] MIN WITH GOLD FLASH ON THE REMAINDER OVER 0.76μm [.000030] MIN NICKEL PER QQ-N-290.
- 2 1.27μm [.000050] MIN TIN-LEAD PER MIL-T-10727 OVER 0.76μm [.000030] MIN NICKEL PER QQ-N-290.
- 3 0.76μm [.000030] MIN GOLD PER MIL-G-45204 ON MATING END FOR A LENGTH OF 5.08 [.200] MIN WITH GOLD FLASH ON THE REMAINDER OVER 0.76μm [.000030] MIN NICKEL PER QQ-N-290.
- 4 GOLD PLATING NEED NOT APPEAR IN THIS AREA.
- 5 REVERSE REELED FOR MINI-APPLICATOR.
- 6 WIRE RANGE 14-18 AWG. INSULATION RANGE 2.79[.110]-3.81[.150].
- 7 0.38μm [.000015] MIN GOLD PER MIL-G-45204 ON MATING END FOR A LENGTH OF 5.08 [.200] MIN, 1.27μm [.000050] MIN TIN-LEAD PER MIL-T-10727 FOR A LENGTH OF 5.69 [.224] MIN ON OPPOSITE END, BOTH OVER 1.27μm [.000050] MIN NICKEL PER QQ-N-290 ON ENTIRE CONTACT.
- 8 1.27μm [.000050] MIN TIN PER MIL-T-10727 OVER 0.76μm [.000030] MIN NICKEL PER QQ-N-290.
- 9 0.38μm [.000015] MIN. GOLD PER MIL-G-45204 ON MATING END FOR A LENGTH OF 5.08 [.200] MIN. WITH GOLD FLASH ON THE REMINDER, OVER 1.27μm [.000050] MIN. NICKEL PER QQ-N-290.
- 10 PRELIMINARY - NOT FOR PRODUCTION.

- 11 OBSOLETE PARTS: OBSOLETE CIS STREAMLINING PER D.RENAUD/D.SINISI
- 12 0.76μm [.000030] MIN GOLD PER MIL-G-45204 ON MATING END FOR A LENGTH OF 5.08 [.200] MIN WITH 1.27μm [.000050] MIN MATTE TIN PLATE IN WIRE CRIMP AREA, BOTH OVER .76μm [.000030] MIN NICKEL PER QQ-N-290.

FINISH	BODY MATERIAL	LOOSE PIECE REF	PART NUMBER
9	CU-NI ALLOY	-	10 1-66598-5
8	BRASS	-	1-66598-4
8	PHOSPHOR BRONZE	-	1-66598-3
8	CU-NI ALLOY	1-66601-2	1-66598-2
3	CU-NI ALLOY	1-66601-0	1-66598-1
8	BRASS	-	1-66598-0
8	BRASS	66601-9	66598-9
7	BRASS	66601-5	66598-8
2	BRASS	-	66598-7
3	PHOSPHOR BRONZE	66601-4	66598-6
2	PHOSPHOR BRONZE	66601-3	66598-5
1	BRASS	-	66598-3
12	BRASS	66601-2	66598-2
2	BRASS	66601-1	66598-1

THIS DRAWING IS A CONTROLLED DOCUMENT.

DWN	M.HOFFECKER	8-11-88
CHK	J.McCLINTON	8-11-88
APVD	-	-
PRODUCT SPEC	-	-
APPLICATION SPEC	-	-
WEIGHT	-	-
CUSTOMER DRAWING	SCALE 8:1	SHEET 1 of 1

TE Connectivity  
 SOCKET ASSEMBLY, .062, TYPE III+  
 SIZE A2 CAGE CODE 00779 DRAWING NO C=66598 RESTRICTED TO -  
 REV Z

## X-ON Electronics

Largest Supplier of Electrical and Electronic Components

*Click to view similar products for [Standard Circular Contacts](#) category:*

*Click to view products by [TE Connectivity](#) manufacturer:*

Other Similar products are found below :

[RC16M23J](#) [133780-1](#) [RM20M13D28](#) [RM24M9D28](#) [RMMX110-1D28](#) [MS3474W10-6P L/C](#) [ELFH02211](#) [ELVP16100E](#) [164-901-CD](#)  
[EN3545007SCE](#) [BV002BSQ20049CZ](#) [BV002SSQ160404CZ](#) [1900ND05S1B00B](#) [166566-1](#) [1900ND04S1X00D](#) [ST-JL05-16S-C3-100](#) [ST-JL05-20S-C1-100](#) [ST-JL05-20S-C2-100](#) [T01-CRIMP-S03](#) [APK-SA16A07-002](#) [27963-15T12](#) [CONT-JL05-08S-C2-10](#) [CONT-JL05-12S-C1-10](#) [RC16M-23T](#) [RFD26L-1D28](#) [BV002ASJ16049CW](#) [JN1-22-20S-R-PKG100](#) [031-50213](#) [031-50565](#) [031-50794](#) [SJS861301M](#) [ST-JL05-16S-C1-100](#) [ST-JL05-20P-C1-100](#) [82911466K](#) [192991-0087](#) [192900-0570](#) [44-100-1414P-1000-101](#) [T3P16FC3LZ](#) [ST-JL05-16S-C2-3500](#)  
[ZP-4016-10NF](#) [CONT-JL05-12P-C1-10](#) [RM20M12G8D28](#) [031-50676](#) [12115010110](#) [RJFTVC2MG](#) [CAP-DACMDPC2](#) [031-50675-002](#)  
[CAP-DD1FDPC2](#) [CAP-DACMDPC1](#) [031-50966-010](#)