

THIS DRAWING IS UNPUBLISHED. RELEASED FOR PUBLICATION  
 © COPYRIGHT - By - ALL RIGHTS RESERVED.

REVISIONS					
P	LTR	DESCRIPTION	DATE	DWN	APVD
AV6		REVISED PER ECO-16-004223	19JUL2016	NK	MZ
AW		REVISED PER ECO-16-017462	08MAR2017	RS	MZ

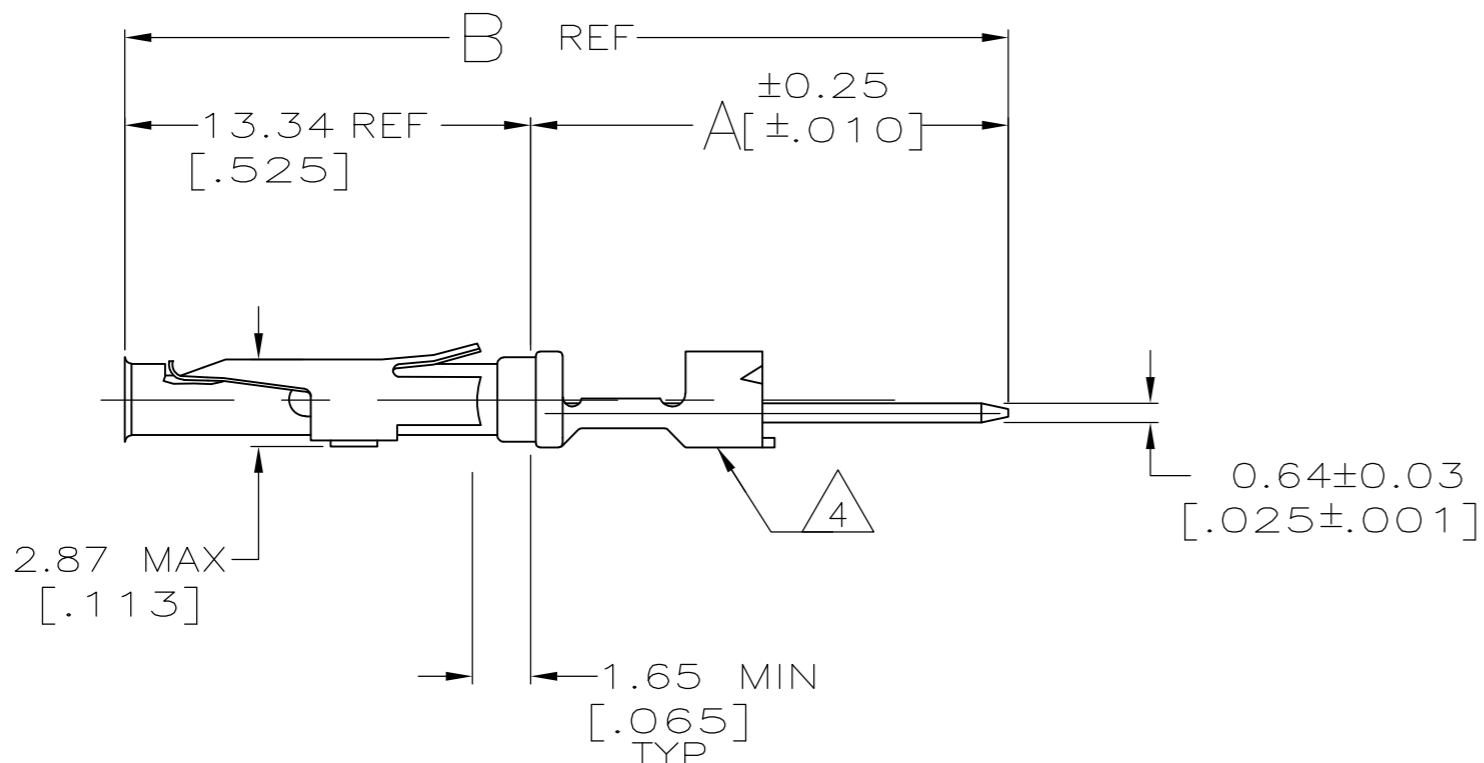
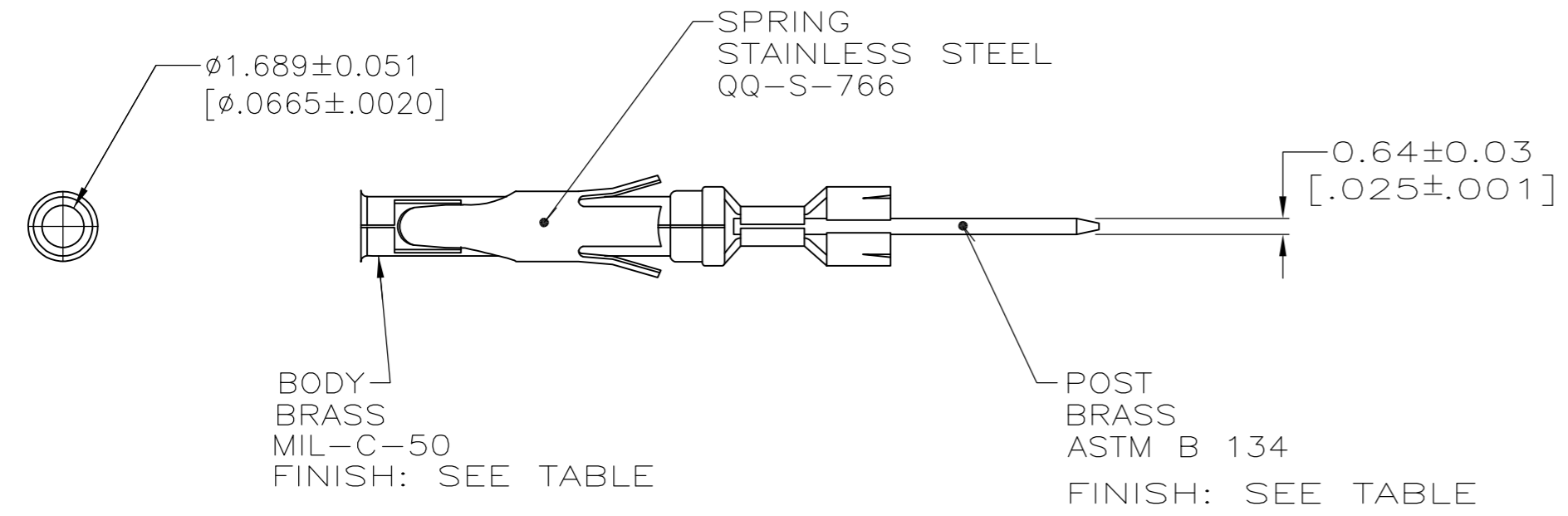

- $\triangle 1$  2.54um [.000100] MIN TIN-LEAD PER MIL-T-10727 OVER  
1.27um [.000050] MIN NICKEL PER QQ-N-290.
- $\triangle 2$  2.76um [.000030] MIN GOLD PER MIL-G-45204 ON MATING END FOR  
A LENGTH OF 5.08 [.200] MIN WITH A UNIFORM GRADIENT TO 0.25um  
[.000010] MIN GOLD PER MIL-G-45204 ON THE REMAINDER OVER  
1.27um [.000050] MIN NICKEL PER QQ-N-290.
- $\triangle 3$  2.54um [.000100] MIN TIN-LEAD PER MIL-T-10727 OVER  
1.27um [.000050] MIN NICKEL PER QQ-N-290.
- $\triangle 4$  GOLD PLATING NEED NOT APPEAR ON WIRE BARREL.
- $\triangle 5$  0.76um [.000030] MIN GOLD PER MIL-G-45204 ON MATING END FOR  
A LENGTH OF 5.08 [.200] MIN, GOLD FLASH ON THE REMAINDER OVER  
1.27um [.000050] MIN NICKEL PER QQ-N-290.
- $\triangle 6$  .000100 MIN TIN PER MIL-T-10727, OVER  
.000050 MIN NICKEL PER QQ-N-290.
- $\triangle 7$  .000030 MIN GOLD PER MIL-G-45204, OVER  
.000050 MIN NICKEL PER QQ-N-290.
- $\triangle 8$  OBSOLETE PARTS: OBSOLETE CIS STREAMLINING PER D.RENAUD/D.SINISI

	PRELIMINARY	34.44 [1.356]	21.11 [.831]	2	$\triangle 7$	$\triangle 6$	5-66461-7
		29.13 [1.147]	15.80 [.622]	1	$\triangle 6$	$\triangle 2$	5-66461-6
		29.13 [1.147]	15.80 [.622]	1	$\triangle 6$	$\triangle 5$	5-66461-5
		29.13 [1.147]	15.80 [.622]	1	$\triangle 6$	$\triangle 6$	5-66461-4
	PRELIMINARY	34.44 [1.356]	21.11 [.831]	2	$\triangle 3$	$\triangle 1$	5-66461-3
	OBSOLETE	49.40 [1.945]	36.07 [1.420]	SPECIAL	$\triangle 3$	$\triangle 5$	<del>5-66461-1</del>
$\triangle 8$	OBSOLETE	30.68 [1.208]	17.35 [.683]	SPECIAL	$\triangle 3$	$\triangle 1$	<del>2-66461-2</del>
$\triangle 8$	SUPERSEDED	34.44 [1.356]	21.11 [.831]	2	$\triangle 3$	$\triangle 1$	<del>2-66461-1</del>
	OBSOLETE	41.48 [1.633]	28.14 [1.108]	SPECIAL	$\triangle 3$	$\triangle 5$	<del>2-66461-0</del>
		30.68 [1.208]	17.35 [.683]	SPECIAL	$\triangle 3$	$\triangle 1$	1-66461-9
	OBSOLETE	29.64 [1.167]	16.31 [.642]	SPECIAL	$\triangle 3$	$\triangle 5$	<del>1-66461-8</del>
	OBSOLETE	27.97 [1.101]	14.63 [.576]	SPECIAL	$\triangle 3$	$\triangle 5$	<del>1-66461-7</del>
	OBSOLETE	25.68 [1.011]	12.34 [.486]	SPECIAL	$\triangle 3$	$\triangle 5$	<del>1-66461-3</del>
		43.46 [1.711]	30.12 [1.186]	SPECIAL	$\triangle 3$	$\triangle 5$	<del>1-66461-0</del>
		39.24 [1.545]	25.91 [1.020]	3	$\triangle 3$	$\triangle 5$	66461-9
		34.44 [1.356]	21.11 [.831]	2	$\triangle 3$	$\triangle 5$	66461-8
		29.13 [1.147]	15.80 [.622]	1	$\triangle 3$	$\triangle 5$	66461-7
		39.24 [1.545]	25.91 [1.020]	3	$\triangle 3$	$\triangle 2$	66461-6
		34.44 [1.356]	21.11 [.831]	2	$\triangle 3$	$\triangle 2$	66461-5
		29.13 [1.147]	15.80 [.622]	1	$\triangle 3$	$\triangle 2$	66461-4
		39.24 [1.545]	25.91 [1.020]	3	$\triangle 3$	$\triangle 1$	66461-3
		34.44 [1.356]	21.11 [.831]	2	$\triangle 3$	$\triangle 1$	66461-2
		29.13 [1.147]	15.80 [.622]	1	$\triangle 3$	$\triangle 1$	66461-1
		B	A	NO OF TERM	POST FINISH	BODY FINISH	PART NUMBER

THIS DRAWING IS A CONTROLLED DOCUMENT. DWN 07/02/92  
 C.OBERMAN  
 CHK 7-8-92  
 R.STONE  
 APVD 7-10-92  
 C.OBERMANN  
 PRODUCT SPEC

TE Connectivity

NAME SOCKET CONTACT, CRIMPED  
 .062 DIA, .025 X .025 POST,  
 AUTOWIRE

SIZE A2 CAGE CODE 00779 DRAWING NO C-66461 RESTRICTED TO

MATERIAL SEE CALLOUT FINISH SEE CALLOUT WEIGHT - SCALE 4:1 SHEET 1 OF 2 REV AW

CUSTOMER DRAWING

THIS DRAWING IS UNPUBLISHED. RELEASED FOR PUBLICATION  
 © COPYRIGHT - By - ALL RIGHTS RESERVED.

REVISIONS					
P	LTR	DESCRIPTION	DATE	DWN	APVD
-	-	SEE SHEET 1	-	-	-
-	-	SEE TABLE 1	-	-	-

	B	A	NO OF TERM	POST FINISH	BODY FINISH	PART NUMBER
			SPECIAL	△6	△5	<del>9-66461-9</del>
			SPECIAL	△6	△6	7-66461-0
△8	OBSOLETE		SPECIAL	△6	△6	<del>6-66461-5</del>
			SPECIAL	△6	△5	6-66461-4
			3	△6	△5	6-66461-3
			2	△6	△5	6-66461-2
△8	OBSOLETE		3	△6	△2	<del>6-66461-1</del>
			2	△6	△2	<del>6-66461-0</del>
			3	△6	△6	5-66461-9
			2	△6	△6	5-66461-8

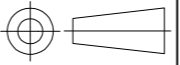
THIS DRAWING IS A CONTROLLED DOCUMENT.		DWN C.OBERMAN 07/02/92	 TE Connectivity	
		CHK R.STONE 7-8-92		
		APVD C.OBERMANN 7-10-92	NAME	
DIMENSIONS: INCHES		TOLERANCES UNLESS OTHERWISE SPECIFIED:		SOCKET CONTACT, CRIMPED .062 DIA, .025 X .025 POST, AUTOWIRE
		0 PLC ± - 1 PLC ± - 2 PLC ± 0.13 [.005] 3 PLC ± - 4 PLC ± - ANGLES ± -		
MATERIAL SEE CALLOUT		FINISH SEE CALLOUT		RESTRICTED TO
		WEIGHT -	SIZE A2	CAGE CODE 00779
		DRAWING NO C-66461		REV AW
		CUSTOMER DRAWING		SCALE 4:1 SHEET 2 of 2

## X-ON Electronics

Largest Supplier of Electrical and Electronic Components

*Click to view similar products for [Standard Circular Contacts](#) category:*

*Click to view products by [TE Connectivity](#) manufacturer:*

Other Similar products are found below :

[RC16M23J](#) [133780-1](#) [RM20M13D28](#) [RM24M9D28](#) [RMMX110-1D28](#) [MS3474W10-6P L/C](#) [ELVP16100E](#) [164-901-CD](#) [EN3545007SCE](#)  
[BV002BSQ20049CZ](#) [BV002SSQ160404CZ](#) [1900ND05S1B00B](#) [166566-1](#) [1900ND04S1X00D](#) [ST-JL05-16S-C3-100](#) [ST-JL05-20S-C1-100](#)  
[ST-JL05-20S-C2-100](#) [T01-CRIMP-S03](#) [APK-SA16A07-002](#) [27963-15T12](#) [CONT-JL05-08S-C2-10](#) [CONT-JL05-12S-C1-10](#) [RC16M-23T](#)  
[RFD26L-1D28](#) [BV002ASJ16049CW](#) [33505815019](#) [JN1-22-20S-R-PKG100](#) [031-50213](#) [031-50565](#) [031-50794](#) [ELFH08251](#) [ELFP0641GE](#)  
[SJS861301M](#) [ST-JL05-16S-C1-100](#) [ST-JL05-20P-C1-100](#) [82911466K](#) [ESLM03200](#) [192991-0087](#) [192900-0570](#) [ELFH07251](#) [44-100-1414P-](#)  
[1000-101](#) [T3P16FC3LZ](#) [ST-JL05-16S-C2-3500](#) [ZP-4016-10NF](#) [CONT-JL05-12P-C1-10](#) [RM20M12G8D28](#) [031-50676](#) [12115010110](#)  
[RJFTVC2MG](#) [CAP-DACMDPC2](#)