

THIS DRAWING IS UNPUBLISHED. RELEASED FOR PUBLICATION
 © COPYRIGHT - By - ALL RIGHTS RESERVED.

| REVISIONS | | | | | |
|-----------|-----|---------------------------|-----------|-----|------|
| P | LTR | DESCRIPTION | DATE | DWN | APVD |
| AV6 | | REVISED PER ECO-16-004223 | 19JUL2016 | NK | MZ |
| AW | | REVISED PER ECO-16-017462 | 08MAR2017 | RS | MZ |

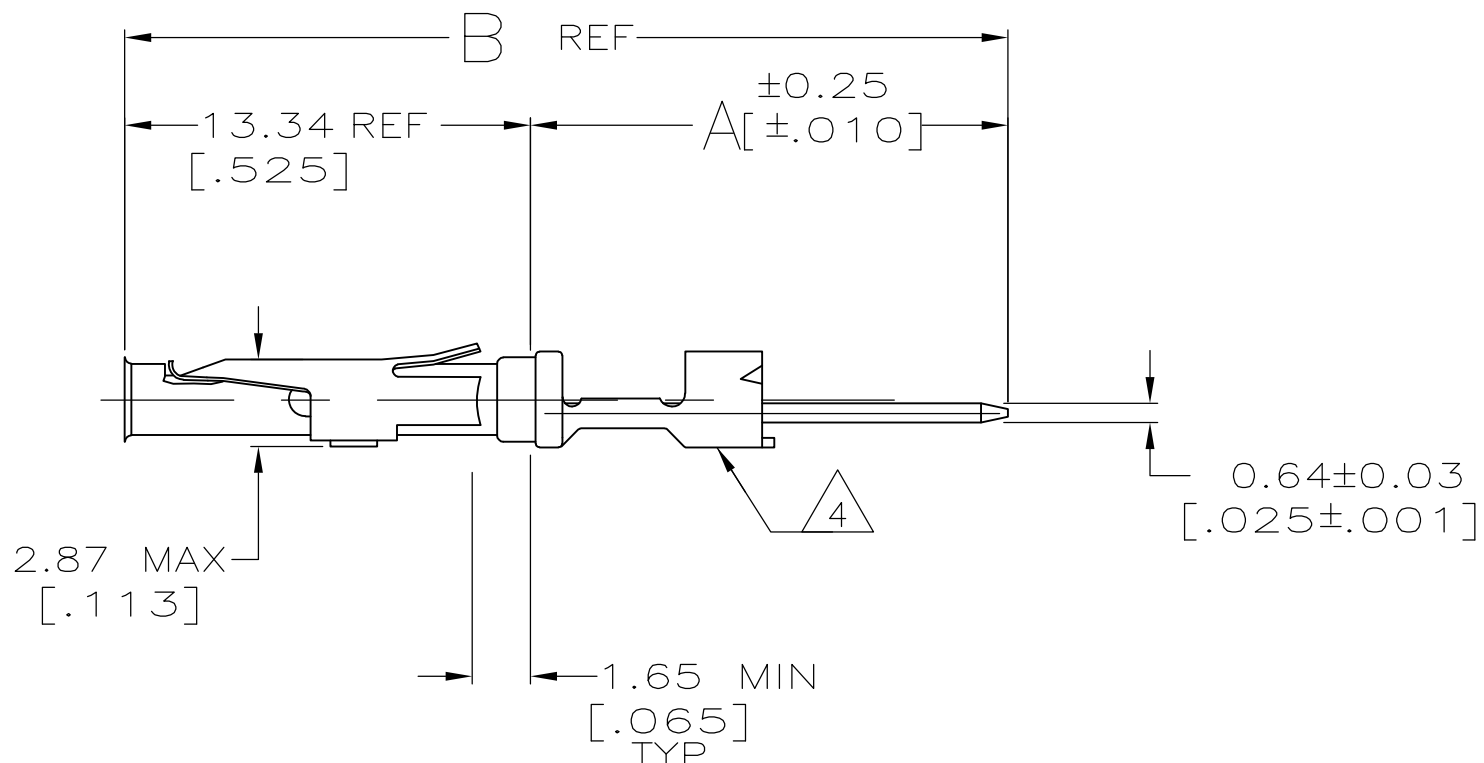
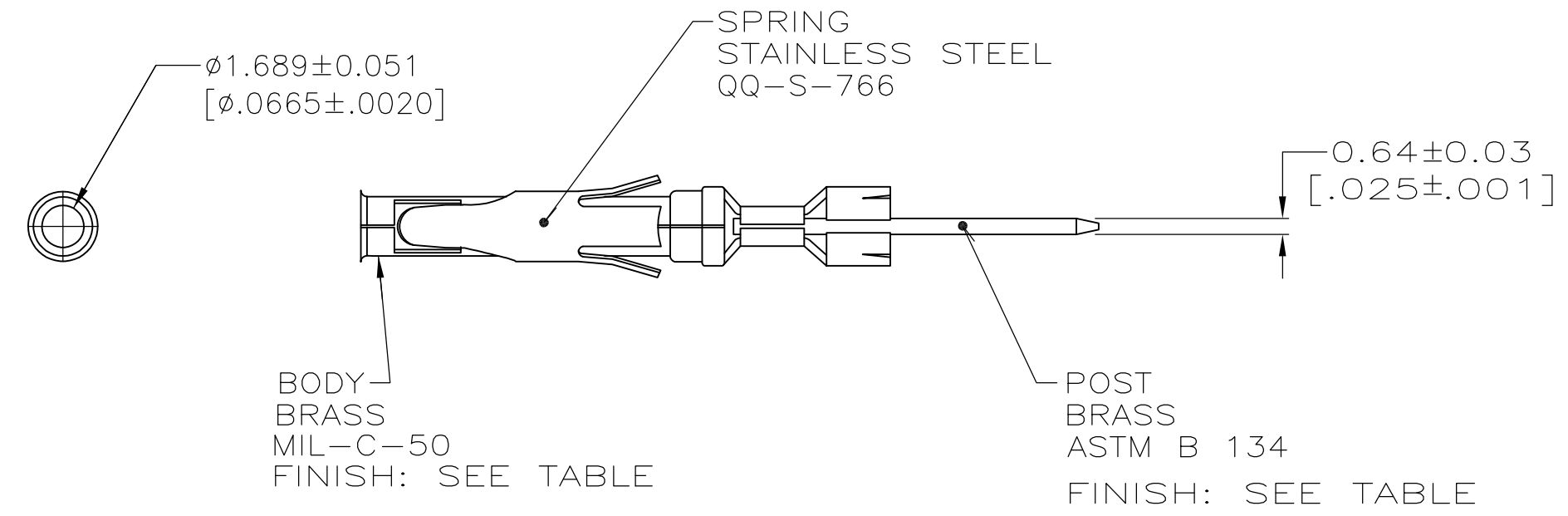

- 1 2.54um [.000100] MIN TIN-LEAD PER MIL-T-10727 OVER
1.27um [.000050] MIN NICKEL PER QQ-N-290.
- 2 2.76um [.000030] MIN GOLD PER MIL-G-45204 ON MATING END FOR
A LENGTH OF 5.08 [.200] MIN WITH A UNIFORM GRADIENT TO 0.25um
[.000010] MIN GOLD PER MIL-G-45204 ON THE REMAINDER OVER
1.27um [.000050] MIN NICKEL PER QQ-N-290.
- 3 2.54um [.000100] MIN TIN-LEAD PER MIL-T-10727 OVER
1.27um [.000050] MIN NICKEL PER QQ-N-290.
- 4 GOLD PLATING NEED NOT APPEAR ON WIRE BARREL.
- 5 0.76um [.000030] MIN GOLD PER MIL-G-45204 ON MATING END FOR
A LENGTH OF 5.08 [.200] MIN, GOLD FLASH ON THE REMAINDER OVER
1.27um [.000050] MIN NICKEL PER QQ-N-290.
- 6 .000100 MIN TIN PER MIL-T-10727, OVER
.000050 MIN NICKEL PER QQ-N-290.
- 7 .000030 MIN GOLD PER MIL-G-45204, OVER
.000050 MIN NICKEL PER QQ-N-290.
- 8 OBSOLETE PARTS: OBSOLETE CIS STREAMLINING PER D.RENAUD/D.SINISI

| | | | | | | | |
|---|-------------|------------------|------------------|------------|-------------|-------------|----------------------|
| | PRELIMINARY | 34.44 [1.356] | 21.11 [.831] | 2 | 7 | 6 | 5-66461-7 |
| | | 29.13 [1.147] | 15.80 [.622] | 1 | 6 | 2 | 5-66461-6 |
| | | 29.13 [1.147] | 15.80 [.622] | 1 | 6 | 5 | 5-66461-5 |
| | | 29.13 [1.147] | 15.80 [.622] | 1 | 6 | 6 | 5-66461-4 |
| | PRELIMINARY | 34.44 [1.356] | 21.11 [.831] | 2 | 3 | 1 | 5-66461-3 |
| | OBSOLETE | 49.40 [1.945] | 36.07 [1.420] | SPECIAL | 3 | 5 | 5-66461-1 |
| 8 | OBSOLETE | 30.68 [1.208] | 17.35 [.683] | SPECIAL | 3 | 1 | 2-66461-2 |
| 8 | SUPERSEDED | 34.44 [1.356] | 21.11 [.831] | 2 | 3 | 1 | 2-66461-1 |
| | OBSOLETE | 41.48 [1.633] | 28.14 [1.108] | SPECIAL | 3 | 5 | 2-66461-0 |
| | | 30.68 [1.208] | 17.35 [.683] | SPECIAL | 3 | 1 | 1-66461-9 |
| | OBSOLETE | 29.64 [1.167] | 16.31 [.642] | SPECIAL | 3 | 5 | 1-66461-8 |
| | OBSOLETE | 27.97 [1.101] | 14.63 [.576] | SPECIAL | 3 | 5 | 1-66461-7 |
| | OBSOLETE | 25.68 [1.011] | 12.34 [.486] | SPECIAL | 3 | 5 | 1-66461-3 |
| | | 43.46 [1.711] | 30.12 [1.186] | SPECIAL | 3 | 5 | 1-66461-0 |
| | | 39.24 [1.545] | 25.91 [1.020] | 3 | 3 | 5 | 66461-9 |
| | | 34.44 [1.356] | 21.11 [.831] | 2 | 3 | 5 | 66461-8 |
| | | 29.13 [1.147] | 15.80 [.622] | 1 | 3 | 5 | 66461-7 |
| | | 39.24 [1.545] | 25.91 [1.020] | 3 | 3 | 2 | 66461-6 |
| | | 34.44 [1.356] | 21.11 [.831] | 2 | 3 | 2 | 66461-5 |
| | | 29.13 [1.147] | 15.80 [.622] | 1 | 3 | 2 | 66461-4 |
| | | 39.24 [1.545] | 25.91 [1.020] | 3 | 3 | 1 | 66461-3 |
| | | 34.44 [1.356] | 21.11 [.831] | 2 | 3 | 1 | 66461-2 |
| | | 29.13 [1.147] | 15.80 [.622] | 1 | 3 | 1 | 66461-1 |
| | | B | A | NO OF TERM | POST FINISH | BODY FINISH | PART NUMBER |

THIS DRAWING IS A CONTROLLED DOCUMENT. DWN C.OBERMAN 07/02/92
 CHK R.STONE 7-8-92
 APVD C.OBERMANN 7-10-92
 PRODUCT SPEC
 APPLICATION SPEC
 MATERIAL SEE CALLOUT
 FINISH SEE CALLOUT
 WEIGHT -
 CUSTOMER DRAWING

TE TE Connectivity
 NAME SOCKET CONTACT, CRIMPED
 .062 DIA, .025 X .025 POST,
 AUTOWIRE
 SIZE A2 CAGE CODE 00779 DRAWING NO C-66461 RESTRICTED TO -
 SCALE 4:1 SHEET 1 OF 2 REV AW

THIS DRAWING IS UNPUBLISHED. RELEASED FOR PUBLICATION
 © COPYRIGHT - By - ALL RIGHTS RESERVED.

| REVISIONS | | | | | |
|-----------|-----|-------------|------|-----|------|
| P | LTR | DESCRIPTION | DATE | DWN | APVD |
| - | - | SEE SHEET 1 | - | - | - |
| - | - | SEE TABLE 1 | - | - | - |

| | B | A | NO OF TERM | POST FINISH | BODY FINISH | PART NUMBER |
|----|----------|---|------------|-------------|-------------|----------------------|
| | | | | △6 | △5 | 9-66461-9 |
| | | | | △6 | △6 | 7-66461-0 |
| △8 | OBSOLETE | | | △6 | △6 | 6-66461-5 |
| | | | | △6 | △5 | 6-66461-4 |
| | | | | △6 | △5 | 6-66461-3 |
| | | | | △6 | △5 | 6-66461-2 |
| △8 | OBSOLETE | | | △6 | △2 | 6-66461-1 |
| | | | | △6 | △2 | 6-66461-0 |
| | | | | △6 | △6 | 5-66461-9 |
| | | | | △6 | △6 | 5-66461-8 |

| | | | | | | | | | | | | | | | | | |
|--|---------------|-------------------------------|--|--------------|-----------------|-------|---------------|-------|-----|-------|-----|--------|-----|-------------------|------------|--------------------|-----------------------|
| THIS DRAWING IS A CONTROLLED DOCUMENT. | | DWN C.OBERMAN 07/02/92 | STE TE Connectivity | | | | | | | | | | | | | | |
| DIMENSIONS: INCHES | | CHK R.STONE 7-8-92 | | | | | | | | | | | | | | | |
| TOLERANCES UNLESS OTHERWISE SPECIFIED: | | APVD C.OBERMANN 7-10-92 | NAME SOCKET CONTACT, CRIMPED .062 DIA, .025 X .025 POST, AUTOWIRE | | | | | | | | | | | | | | |
| <table border="1"> <tr><td>0 PLC</td><td>± -</td></tr> <tr><td>1 PLC</td><td>± -</td></tr> <tr><td>2 PLC</td><td>± 0.13 [.005]</td></tr> <tr><td>3 PLC</td><td>± -</td></tr> <tr><td>4 PLC</td><td>± -</td></tr> <tr><td>ANGLES</td><td>± -</td></tr> </table> | | 0 PLC | ± - | 1 PLC | ± - | 2 PLC | ± 0.13 [.005] | 3 PLC | ± - | 4 PLC | ± - | ANGLES | ± - | PRODUCT SPEC - | SIZE A2 | CAGE CODE 00779 | DRAWING NO C-66461 |
| 0 PLC | ± - | | | | | | | | | | | | | | | | |
| 1 PLC | ± - | | | | | | | | | | | | | | | | |
| 2 PLC | ± 0.13 [.005] | | | | | | | | | | | | | | | | |
| 3 PLC | ± - | | | | | | | | | | | | | | | | |
| 4 PLC | ± - | | | | | | | | | | | | | | | | |
| ANGLES | ± - | | | | | | | | | | | | | | | | |
| MATERIAL SEE CALLOUT | | FINISH SEE CALLOUT | WEIGHT - | SCALE 4:1 | SHEET 2 of 2 | | | | | | | | | | | | |
| CUSTOMER DRAWING | | | RESTRICTED TO - | REV AW | | | | | | | | | | | | | |

X-ON Electronics

Largest Supplier of Electrical and Electronic Components

Click to view similar products for [Standard Circular Contacts](#) category:

Click to view products by [TE Connectivity](#) manufacturer:

Other Similar products are found below :

[RC16M23J](#) [133780-1](#) [RM20M13D28](#) [RM24M9D28](#) [RMMX110-1D28](#) [ELFH02211](#) [ELVP16100E](#) [164-901-CD](#) [BACS16X1A](#)
[EN3545007SCE](#) [BV002BSQ20049CZ](#) [BV002SSQ160404CZ](#) [1900ND05S1B00B](#) [SJS862201](#) [166566-1](#) [1900ND04S1X00D](#) [ST-JL05-16S-](#)
[C3-100](#) [ST-JL05-20S-C1-100](#) [ST-JL05-20S-C2-100](#) [T01-CRIMP-S03](#) [APK-SA16A07-002](#) [27963-15T12](#) [CONT-JL05-08S-C2-10](#) [CONT-](#)
[JL05-12S-C1-10](#) [RC16M-23T](#) [RFD26L-1D28](#) [BV002ASJ16049CW](#) [33505815019](#) [JN1-22-20S-R-PKG100](#) [031-50213](#) [031-50794](#)
[ELFH08251](#) [ELFP0641GE](#) [SJS861301M](#) [ST-JL05-16S-C1-100](#) [ST-JL05-20P-C1-100](#) [82911466K](#) [82911467NK](#) [ESLM03200](#) [192991-0087](#)
[192900-0570](#) [T3P16FC3LZ](#) [ST-JL05-16S-C2-3500](#) [ZP-4016-10NF](#) [CONT-JL05-12P-C1-10](#) [RM20M12G8D28](#) [031-50676](#) [12115010110](#)
[RJFTVC2MG](#) [CAP-DACMDPC2](#)