

THIS DRAWING IS UNPUBLISHED. RELEASED FOR PUBLICATION
 © COPYRIGHT 2017 By TE Connectivity ALL RIGHTS RESERVED.

REVISIONS					
P	LTR	DESCRIPTION	DATE	DWN	APVD
	K2	RELEASED AS PER ECO-17-001304	31JAN2017	NN	MP

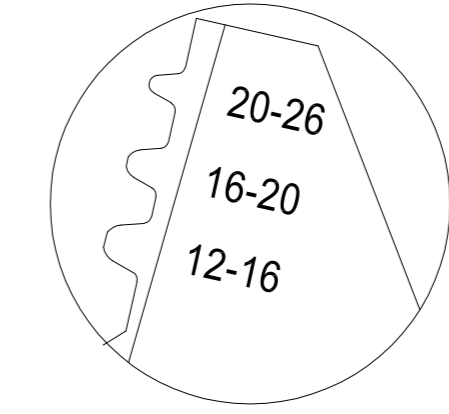
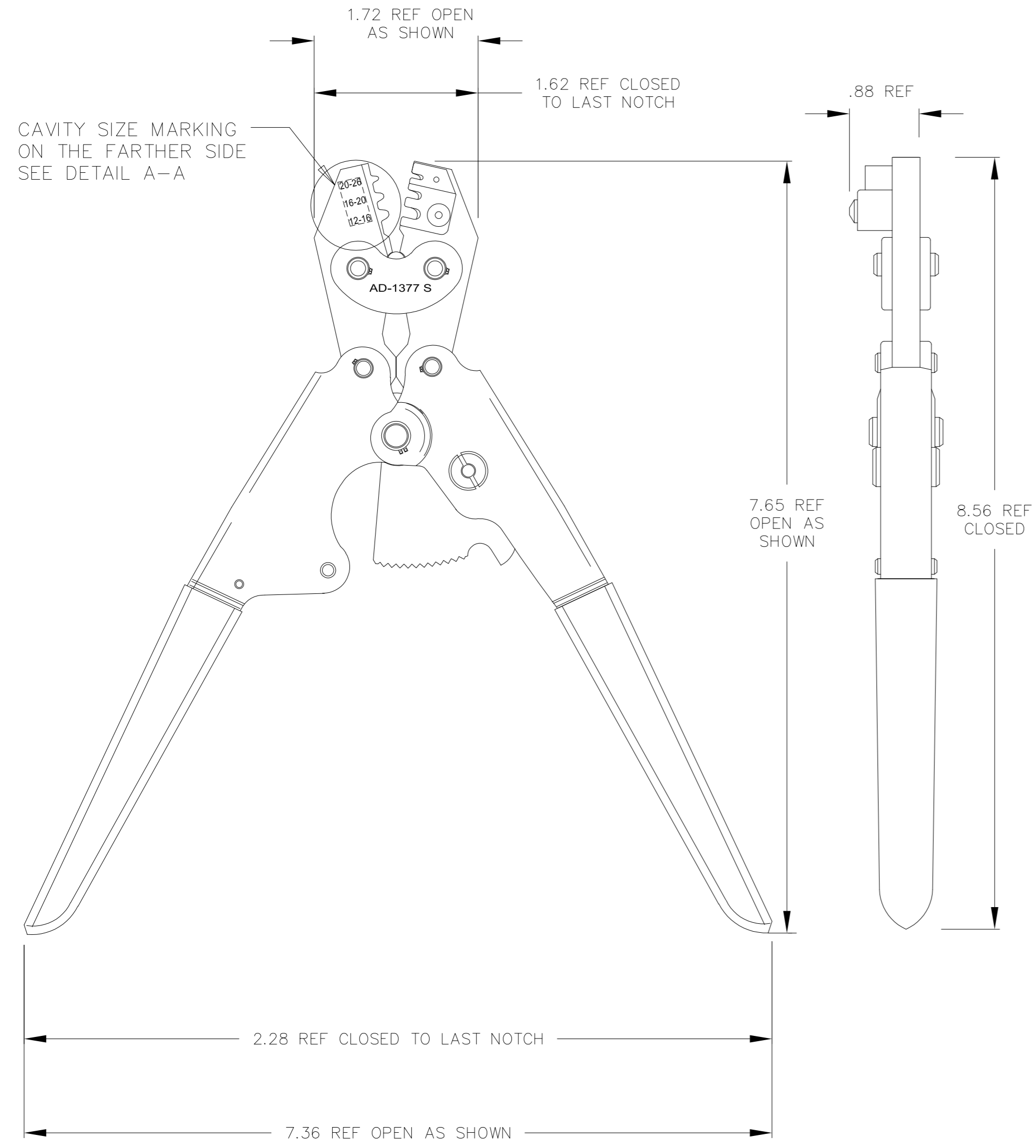

DETAIL A-A
CAVITY SIZE MARKING

NOTES:

- UNLESS OTHERWISE SPECIFIED, DIMENSIONS ARE IN INCHES.
- THE AD-1377 CRIMP TOOL IS DESIGNED TO MAKE WIRE SPLICES UTILIZING TYCO ELECTRONICS CRIMP SPLICES OF THE FOLLOWING SIZES:

TOOL CAVITY	12 - 16		16 - 20		20 - 26	
CRIMP SPLICER SIZE	I.D.	O.D.	I.D.	O.D.	I.D.	O.D.
	.102	.153	.069	.106	.050	.080
	.097	.147	.064	.101	.045	.075
- WHEN MADE WITH A CALIBRATED AD-1377 CRIMP TOOL, THESE WIRE SPLICES WILL MEET THE VOLTAGE DROP AND TENSILE STRENGTH REQUIREMENTS OF THE APPLICABLE TYCO ELECTRONICS CUSTOMER DRAWING FOR CRIMP SPLICING SYSTEMS.
- A CALIBRATED AD-1377 CRIMP TOOL HAS THE FOLLOWING CHARACTERISTICS:
 - AD-1377 CRIMP TOOL IS SUPPLIED WITH A FACTORY-SET RATCHET ADJUSTMENT: A COMPRESSIVE FORCE OF 40-50 LBS APPLIED 1.25 ± .12 INCHES FROM THE END OF THE HANDLES SHALL BE REQUIRED TO COMPLETELY CLOSE THE JAWS BEFORE THE RATCHET MECHANISM RELEASES THE HANDLES. THE FACTORY SETTINGS OF THE RATCHET ARE NOT DESIGNED TO BE ADJUSTED.
 - TO CALIBRATE THE TOOL, USE A "GO/NO GO" GAUGE. WITH THE JAWS OF THE TOOL FULLY CLOSED (TIPS TOUCHING AND RATCHET IN LAST NOTCH), THE "GO" GAUGE SHALL FIT IN THE SPACE BETWEEN THE INDENTER AND ITS CORRESPONDING CAVITY. THE "NO GO" GAUGE SIDE SHALL NOT FIT IN THIS SPACE. GAUGE SIZES ARE AS FOLLOWS:

TOOL CAVITY	"GO"	"NO GO"
12 - 16	.062 DIA.	.072 DIA.
16 - 20	.042 DIA.	.052 DIA.
20 - 26	.025 DIA.	.035 DIA.
- ON RECEIPT OF A NEW TOOL, THE CUSTOMER SHOULD CALIBRATE AS PER INSTRUCTION B.
- THE AD-1377 IS NOT SUPPLIED WITH A CALIBRATION CERTIFICATE. THE PRODUCT WILL BE SUPPLIED IN CONFORMANCE WITH OUR DRAWING.
- IDENTIFICATION OF THE SUGGESTED SOURCE(S) OF SUPPLY HEREON IS NOT TO BE CONSTRUED AS A GUARANTEE OF PRESENT OR CONTINUED AVAILABILITY AS A SOURCE OF SUPPLY FOR THE ITEM (S).
- ITEM MARKING: AD-1377 S
PCN# 959025-000
DEPT. 1062

THE TE CONNECTIVITY AD-1386 CRIMP TOOL GAUGE IS RECOMMENDED FOR THIS PURPOSE.

THIS DRAWING IS A CONTROLLED DOCUMENT.		DWN N. NAGAR 12OCT2016			
DIMENSIONS: INCHES		CHK -			
TOLERANCES UNLESS OTHERWISE SPECIFIED:		APVD M. POPE 13OCT2016	PRODUCT SPEC		
0 PLC ± -		APPLICATION SPEC			
1 PLC ± -		-			
2 PLC ± -		-			
3 PLC ± -		-			
4 PLC ± -		-			
ANGLES ± -		-			
FINISH		-			
MATERIAL		WEIGHT 0		SIZE A2	CAGE CODE 00779
		CUSTOMER DRAWING		DRAWING NO AD-1377-6	RESTRICTED TO -
		SCALE DNS		SHEET 1 of 1	REV K2

AD-1377-6

X-ON Electronics

Largest Supplier of Electrical and Electronic Components

Click to view similar products for [Crimpers / Crimping Tools](#) category:

Click to view products by [TE Connectivity](#) manufacturer:

Other Similar products are found below :

[TH493-1](#) [63455-1207](#) [7-1579001-9](#) [7-23471-1](#) [124208](#) [DCE.91.073.BVC](#) [DCE.91.130.5MVU](#) [1490357-3](#) [1-59619-8](#) [980285-2](#) [2-305183-0](#)
[240658-1](#) [4-22279-9](#) [3-23620-3](#) [DCE.91.051.BVC](#) [DCE.91.133.BVM](#) [11184809](#) [112108-0003](#) [734768-1](#) [314479-1](#) [354004-2](#) [HT802/DF63-](#)
[2022S-1](#) [89853094A](#) [1-305731-5](#) [125466-2](#) [3-305832-7](#) [455676-1](#) [46000](#) [679298-1](#) [679495-2](#) [E110.010](#) [E110.020](#) [22.014](#) [8-240641-9](#)
[CRIMPIT-F-4](#) [576718-5](#) [7-455888-2](#) [9-1803018-2](#) [1803323-8](#) [2217277-1](#) [1-1633710-8](#) [1803248-9](#) [2-238009-9](#) [4-1803187-7](#) [7-1803187-2](#)
[9-1803018-7](#) [7-1803016-8](#) [6-1803019-9](#) [8-1803017-2](#) [1-1803246-4](#)