

Project No. PRJ-11-000001417	Loc A1	DIST -	REVISIONS			
			#	DATE	OWN	APVD
			C4	06FEB2014	Abr	Raab
			C5	12JUN2014	Abr	Raab
			C6	25AUG2014	Abr	Raab
			C7	21DEC2017	FRAN	KURF

REVISION Aenderungsstand /
NUMBER CODE PRODUCTION TOOL
Nummercode Produktionswerkzeug

MANUFACTURING LOCATION CODE
Kennzahl Produktionsstandort

DATE CODE E.G. WEEK NUMBER 12 YEAR 2013 (1213)
Datumscode z.B. Woche 12 Jahr 2013 (1213)

STANDARD APPLICATION
Standard Anwendung

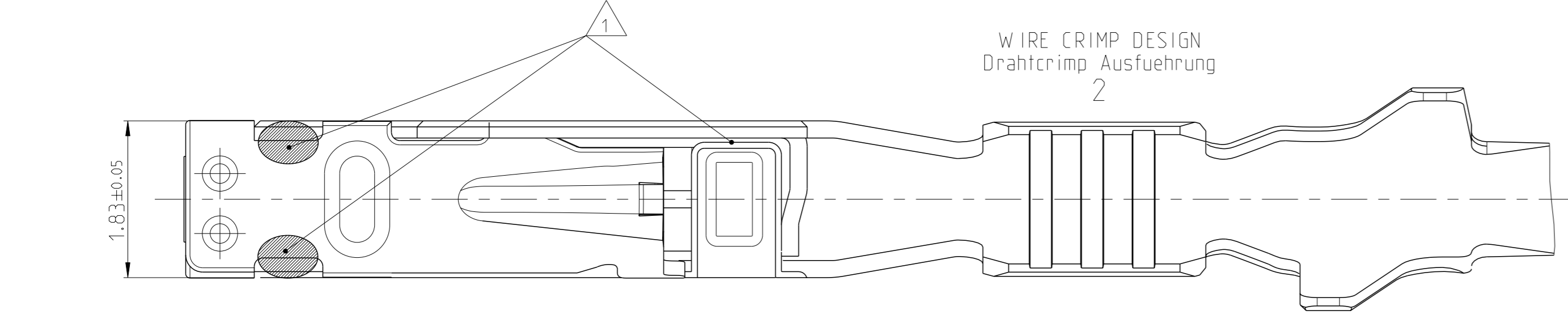
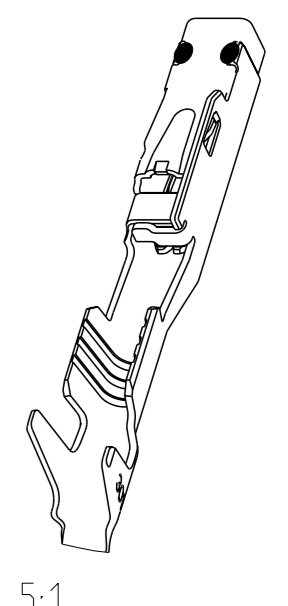
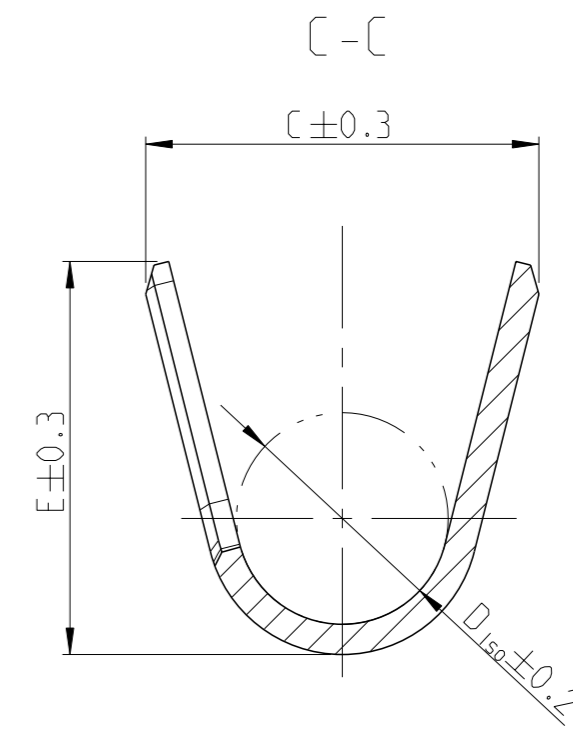
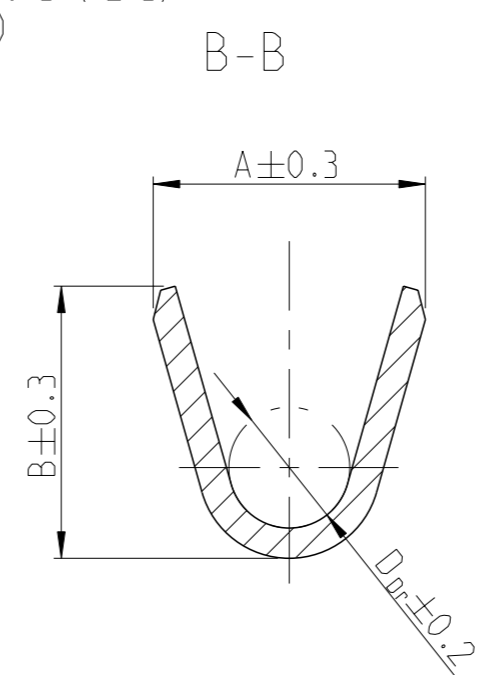
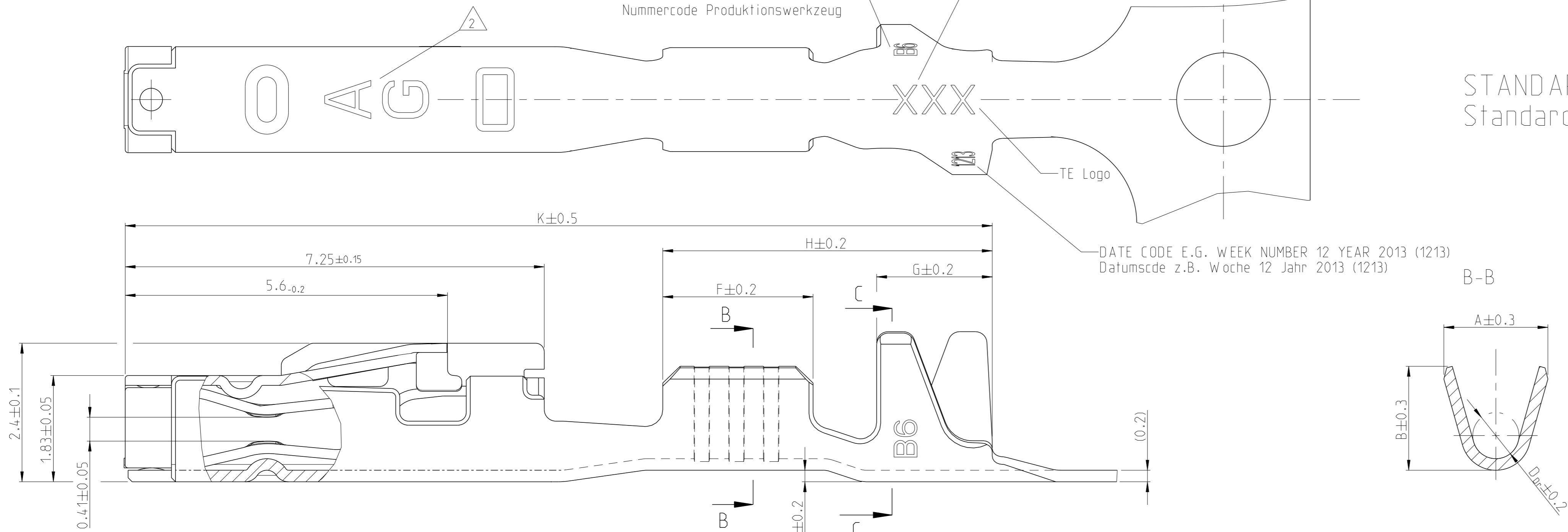

WIRE CRIMP DESIGN
Drahtcrimp Ausfuehrung
2

WIRE CRIMP DESIGN
Drahtcrimp Ausfuehrung
1

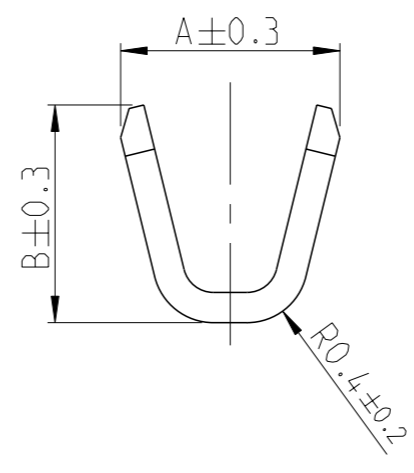
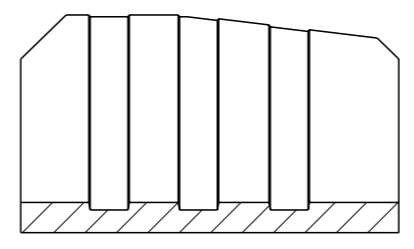

WIRE CRIMP DESIGN
Drahtcrimp Ausfuehrung
3

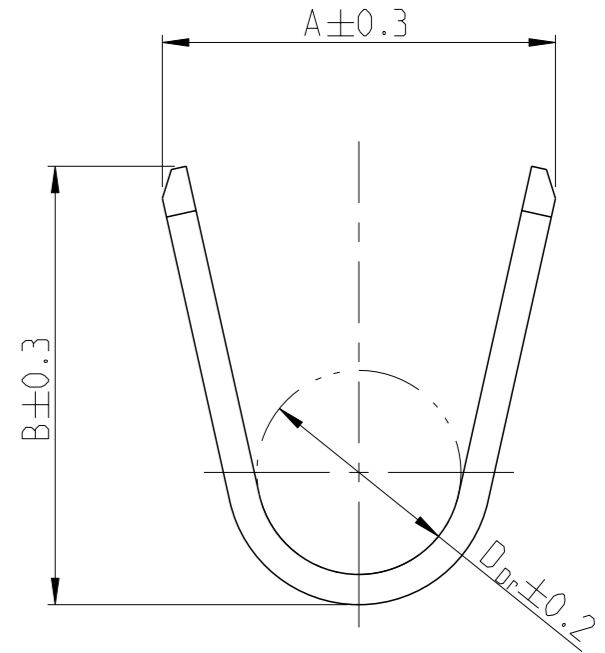
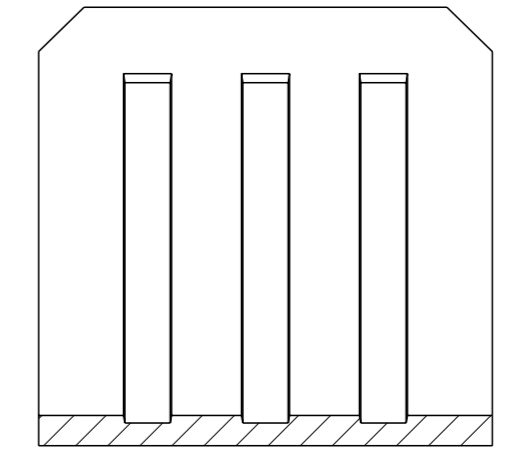

SINGLE WIRE SEALING SYSTEM
Einzelleiterdichtungssystem

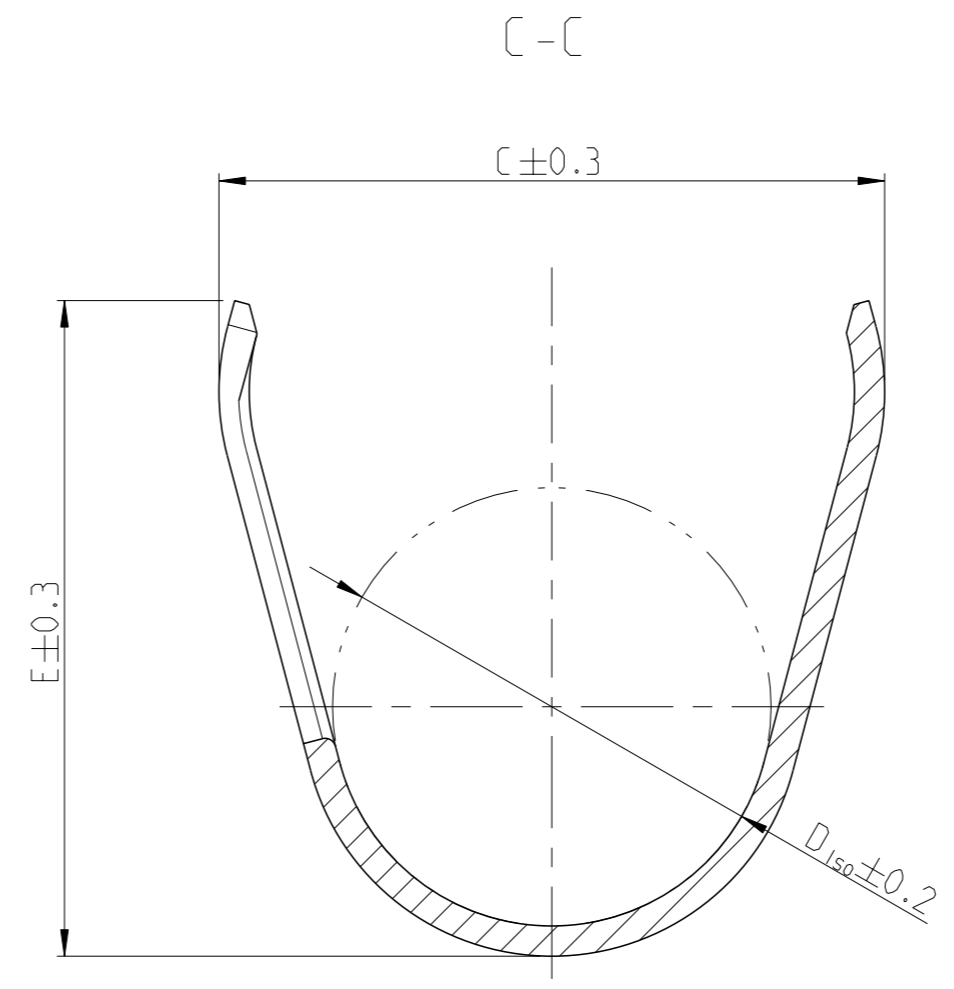
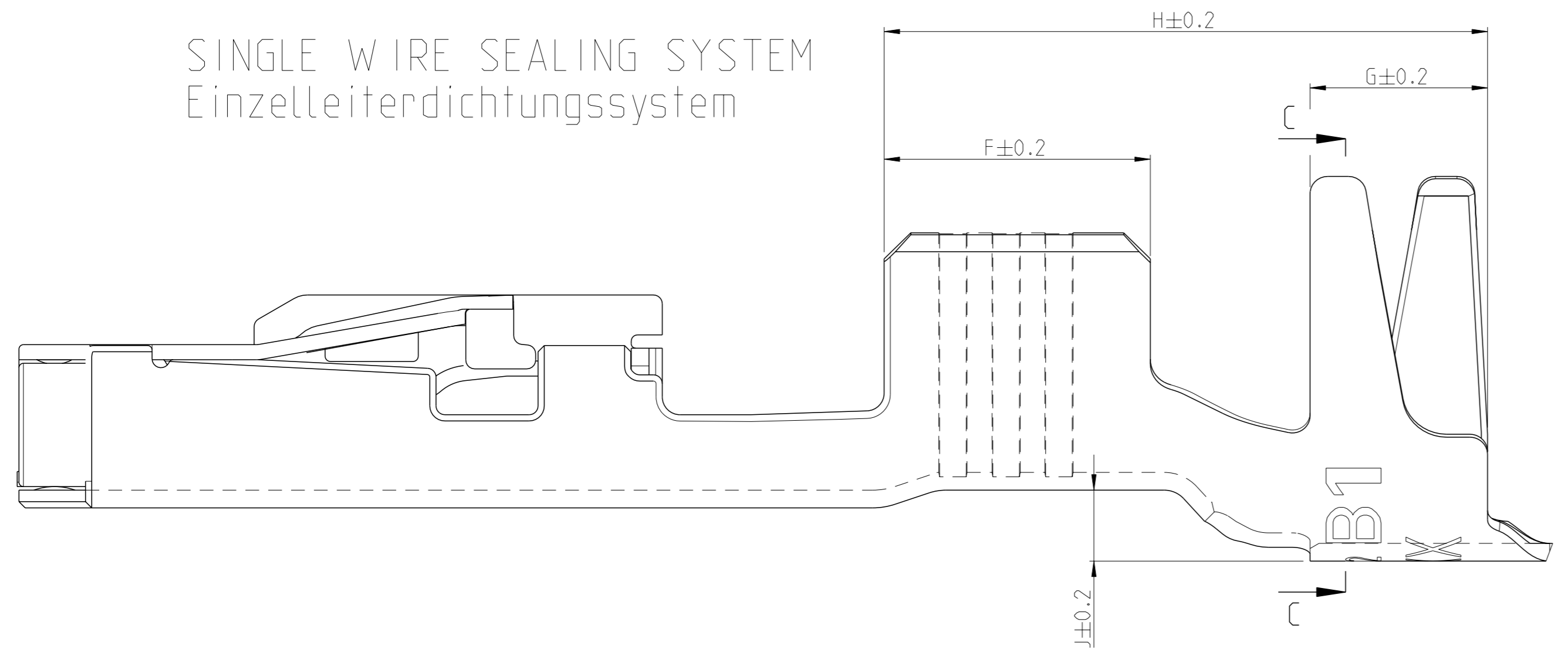

NOTES
Bemerkungen

- 1 LASER WELDED
Lasergeschweisst
- 2 STAMPED INDICATOR FOR PLATING:
- AU GOLD PLATING
- AG SILVER PLATING
- TIN PLATING WITHOUT INDICATOR
Markierung fuer galvanische Ausfuehrung:
- AU vergoldet
- AG versilbert
- verzinkt: ohne Markierung

- 3 TO BE USED ON TAB
1.2±0.1 x 0.6±0.03 MM
geeignet fuer Flachstecker
1.2±0.1 x 0.6±0.03 mm

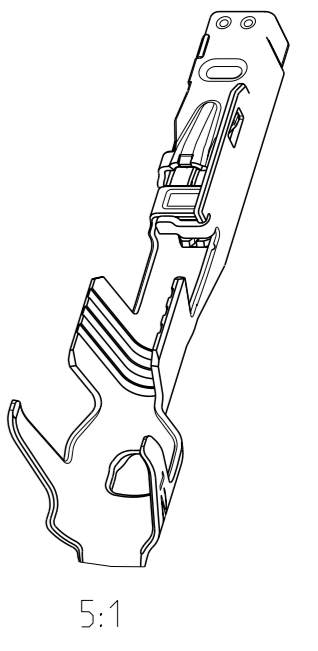

THIS DRAWING IS A CONTROLLED DOCUMENT.		OWN E. Horn	11NOV2011	STE TE Connectivity
DIMENSIONS: mm		CHK R. Meier	11NOV2011	
TOLERANCES UNLESS OTHERWISE SPECIFIED: ±0.2		APVD V. Seigel	11NOV2011	NAME MCON 1.2 LL (LOCKING-LANCE)
MATERIAL		PRODUCT SPEC 108-18782		SIZE 114-18464
FINISH		APPLICATION SPEC		RESTRICTED TO
Customer Drawing		WEIGHT 0.18 g	A1 00779 ©=1452674	SCALE 20:1
		SHEET 1 OF 2		REV C7

LOC	DIST	REVISIONS			
A1	-	REV	DATE	OWN	APVD
		1	SEE SHEET 1	-	-

VERSION / Ausführung	REV.	RANGE Bereich	INSULATION-Ø Isolations-durchm.	AWG	mm ²	BODY Kontakt-körper	SPRING Kontakt-feder	BODY Kontakt-körper	SPRING Kontakt-feder	DESIGN WIRE-CRIMP Ausführung Draht-Crimp	C7											SINGLE WIRE SEAL FOR CAVITY DIAMETER	BLINDPLUG ORDER NO. Blindstopfen Bestell-Nr.	APPLICATION TOOLS Verarbeitungswerkzeuge	
											A	B	D _{Dr}	C	E	D _{ISO}	F	G	H	J	K				TE NO.
STANDARD APPLICATION Standardanwendung	2141970-3	A	0.13-	0.95-	-	0.13	CuSn4	CuNiSi	8	7	1	1.5	1.4	-	4.0	3.9	2.6	2.5	1.9	6.2	0.6	16	SEE APPLICATION SPEC. 114-18464 siehe Verarbeitungsspez. 114-18464		
	2141970-2	A	0.22	0.95-	-	0.17				6	1	1.5	1.4	-	4.0	3.9	2.6	2.5	1.9	6.2	0.6	16			
	2141970-1	A	9	1.2	-	0.22				5	1	1.5	1.4	-	4.0	3.9	2.6	2.5	1.9	6.2	0.6	16			
	7-1452665-3	A	0.25-	1.1-	-	0.25				7	2	1.8	1.8	0.8	4.2	4.3	2.6	2.6	2.0	6.4	0.8	16			
	7-1452665-2	A	0.25-	1.1-	24	-				6	2	1.8	1.8	0.8	4.2	4.3	2.6	2.6	2.0	6.4	0.8	16			
	7-1452665-1	A	0.35	1.75	22	-				5	2	1.8	1.8	0.8	4.2	4.3	2.6	2.6	2.0	6.4	0.8	16			
	7-1452668-3	A	0.5-	1.4-	20	0.5				7	2	2.0	2.1	1.1	4.2	4.3	2.7	2.6	2.0	6.4	0.8	16			
	7-1452668-2	A	0.5-	1.4-	-	0.75				6	2	2.0	2.1	1.1	4.2	4.3	2.7	2.6	2.0	6.4	0.8	16			
	7-1452668-1	A	0.75	1.9	-	0.75				5	2	2.0	2.1	1.1	4.2	4.3	2.7	2.6	2.0	6.4	0.8	16			
	7-1452671-3	A	1-	1.9-	18	-				7	2	2.6	2.9	1.35	4.4	4.3	2.9	3.0	2.0	6.8	0.8	16.55			
	7-1452671-2	A	1-	1.9-	-	1				6	2	2.6	2.9	1.35	4.4	4.3	2.9	3.0	2.0	6.8	0.8	16.55			
	7-1452671-1	A	1.5	2.4	16	-				5	2	2.6	2.9	1.35	4.4	4.3	2.9	3.0	2.0	6.8	0.8	16.55			
7-1452671-1	A	1.5	2.4	-	1.5	5	2	2.6	2.9	1.35	4.4	4.3	2.9	3.0	2.0	6.8	0.8	16.55							

7- VARIANTS FOR NEW APPLICATIONS

- NOTES
Bemerkungen
- 4 ONLY FOR FLR-WIRE SEE DIN 72551, PART 6 AND AWG WIRE ACCORDING DC-SPEC: MS-8288 ; MS-7889 ; MS-9532
Nur fuer FLR-Leitung nach DIN 72551, Teil 6 und AWG Leitung nach DC-SPEC: MS-8288 ; MS-7889 ; MS-9532
 - 5 PRE TIN SnAg 1.0 TO 3.0µm
Vorverzinnt SnAg 1.0 bis 3.0µm
 - 6 SPRING GOLD PLATED MIN. 0.8µm (only contact area)
Kontaktfeder galv. vergoldeft min.0.8µm (nur Kontaktzone)
 - 7 SPRING SILVER PLATED 2.0 TO 5.0µm (only contact area)
Kontaktfeder galv. versilbert 2.0 bis 5.0µm (nur Kontaktzone)
 - 8 BODY PRE TIN Sn 1.0 TO 3.0µm
Kontaktkoerper vorverzinnt Sn 1.0 bis 3.0µm
 - 9 REINFORCED WIRE ACCORDING TO LV 112-4
Zugverstaerkte Leitung nach LV 112-4

VERSION / Ausführung	REV.	RANGE Bereich	INSULATION-Ø Isolations-durchm.	AWG	mm ²	BODY Kontakt-körper	SPRING Kontakt-feder	BODY Kontakt-körper	SPRING Kontakt-feder	DESIGN WIRE-CRIMP Ausführung Draht-Crimp	C7											SINGLE WIRE SEAL FOR CAVITY DIAMETER	BLINDPLUG ORDER NO. Blindstopfen Bestell-Nr.	APPLICATION TOOLS Verarbeitungswerkzeuge	
											A	B	D _{Dr}	C	E	D _{ISO}	F	G	H	J	K				TE NO.
STANDARD APPLICATION Standardanwendung	0-1452665-3	B	0.25-	1.1-	-	0.25	CuSn0.15/0.2	CuNiSi	5	7	2	1.8	1.8	0.8	4.2	4.3	2.6	2.6	2.0	6.4	0.8	16	SEE APPLICATION SPEC. 114-18464 siehe Verarbeitungsspez. 114-18464		
	0-1452665-2	B	0.25-	1.1-	24	-				6	2	1.8	1.8	0.8	4.2	4.3	2.6	2.6	2.0	6.4	0.8	16			
	0-1452665-1	B	0.35	1.75	22	-				5	2	1.8	1.8	0.8	4.2	4.3	2.6	2.6	2.0	6.4	0.8	16			
	0-1452668-3	C	0.5-	1.4-	20	0.5				7	2	2.0	2.1	1.1	4.2	4.3	2.7	2.6	2.0	6.4	0.8	16			
	0-1452668-2	C	0.5-	1.4-	-	0.75				6	2	2.0	2.1	1.1	4.2	4.3	2.7	2.6	2.0	6.4	0.8	16			
	0-1452668-1	C	0.75	1.9	-	0.75				5	2	2.0	2.1	1.1	4.2	4.3	2.7	2.6	2.0	6.4	0.8	16			
	0-1452671-3	B	1-	1.9-	18	-				7	3	2.6	2.9	1.35	4.4	4.3	2.9	3.0	2.0	6.8	0.8	16.55			
	0-1452671-2	B	1-	1.9-	-	1				6	3	2.6	2.9	1.35	4.4	4.3	2.9	3.0	2.0	6.8	0.8	16.55			
	0-1452671-1	B	1.5	2.4	16	-				5	3	2.6	2.9	1.35	4.4	4.3	2.9	3.0	2.0	6.8	0.8	16.55			
	0-1452671-1	B	1.5	2.4	-	1.5				5	3	2.6	2.9	1.35	4.4	4.3	2.9	3.0	2.0	6.8	0.8	16.55			
	0-1452653-3	B	0.25-	1.1-	-	0.25				7	2	1.8	1.8	0.8	4.2	4.3	2.6	2.6	2.0	5.7	0.2	15			
	0-1452653-2	B	0.25-	1.1-	24	-				6	2	1.8	1.8	0.8	4.2	4.3	2.6	2.6	2.0	5.7	0.2	15			
0-1452653-1	B	0.35	1.75	22	-	5	2	1.8	1.8	0.8	4.2	4.3	2.6	2.6	2.0	5.7	0.2	15							
0-1452656-3	C	0.5-	1.4-	20	0.5	7	2	2.0	2.1	1.1	2.7	2.9	1.6	3.0	2.0	6.1	0.2	16							
0-1452656-2	C	0.5-	1.4-	-	0.75	6	2	2.0	2.1	1.1	2.7	2.9	1.6	3.0	2.0	6.1	0.2	16							
0-1452656-1	C	0.75	1.9	-	0.75	5	2	2.0	2.1	1.1	2.7	2.9	1.6	3.0	2.0	6.1	0.2	16							
0-1452659-3	B	1-	1.9-	18	-	7	3	2.6	2.9	1.35	3.7	3.9	2.1	3.0	2.0	6.1	0.2	16							
0-1452659-2	B	1-	1.9-	-	1	6	3	2.6	2.9	1.35	3.7	3.9	2.1	3.0	2.0	6.1	0.2	16							
0-1452659-1	B	1.5	2.4	16	-	5	3	2.6	2.9	1.35	3.7	3.9	2.1	3.0	2.0	6.1	0.2	16							
0-1452659-1	B	1.5	2.4	-	1.5	5	3	2.6	2.9	1.35	3.7	3.9	2.1	3.0	2.0	6.1	0.2	16							

0- VARIANTS SUPERSEDED BY 7- VARIANTS (SEE TABLE ON TOP)

THIS DRAWING IS A CONTROLLED DOCUMENT.

OWNER: E. Horn 11NOV2011
 CHK: R. Meier 11NOV2011
 APVD: V. Seigel 11NOV2011

STE TE Connectivity

NAME: MCON 1.2 LL (LOCKING-LANCE)

SIZE: A1 CAGE CODE: 00779 DRAWING NO: 1452674 RESTRICTED TO: -

SCALE: - SHEET: 2 OF 2 REV: C7

Customer Drawing

X-ON Electronics

Largest Supplier of Electrical and Electronic Components

Click to view similar products for [Automotive Connectors](#) category:

Click to view products by [TE Connectivity](#) manufacturer:

Other Similar products are found below :

[003-018-000](#) [60403001](#) [60993906-B](#) [M902-2131](#) [M902-2161](#) [72.330.1035.1](#) [73.353.4028.0](#) [F119300-B](#) [F166900](#) [F258300-B](#) [F358300-B](#)
[F407400](#) [F444110](#) [F487000](#) [F509500B-B](#) [827153-1](#) [8N1515-32-24P](#) [9-1326729-8](#) [925474-1](#) [928905-1](#) [964562-4](#) [968782-1](#) [GT17SA-8DS-](#)
[HU](#) [98891-1012](#) [98947-1016](#) [12004147](#) [12004475-L](#) [12010290](#) [12010309-B](#) [12015454](#) [12020219-B](#) [12020308](#) [12041318-B](#) [12052225-L](#)
[12052466](#) [12059125](#) [12064869](#) [12004327-B](#) [12010503-B](#) [12015308](#) [12015384](#) [12015909](#) [1-21030-1](#) [12041254](#) [12041318](#) [12047946-B](#)
[12047957](#) [12047957-L](#) [12059473](#) [12066261](#)