

ATLANTIC VERSION TERMINATOR
 INTERFACE ADAPTER

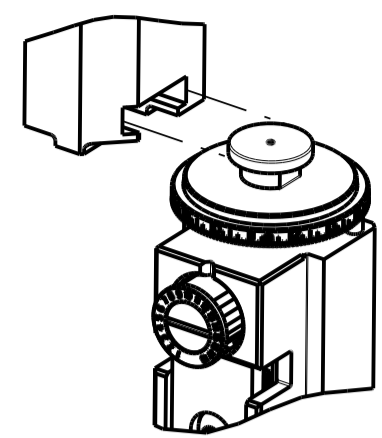

PART NUMBER	REVISION	DESCRIPTION	FEED TYPE
2151033-1	G	FINE CRIMP HEIGHT ADJUST	MECHANICAL
2151033-2	H	FINE CRIMP HEIGHT ADJUST	PNEUMATIC
5-2151033-1	G	SEAL STRIPPER CRIMPER TERMINATING UNIT	MECHANICAL
5-2151033-2	H	SEAL STRIPPER CRIMPER TERMINATING UNIT	PNEUMATIC
7-2151033-1	G	MECHANICAL AND CRIMP TOOLING KIT	MECHANICAL
7-2151033-2	H	PNEUMATIC AND CRIMP TOOLING KIT	PNEUMATIC
7-2151033-7	G	CRIMP TOOLING KIT	-

APPLICATOR DATA

CRIMP	SIZE	TYPE
WIRE	1.78 mm [.070]	F
INSUL	2.54 mm [.100]	F

APPLICATOR INSTRUCTIONS
 408-35042

TERMINAL DATA: TE TERMINAL TE CRIMP SPECIFICATION

TERMINAL NAME: CONTACT, BIFURCATED LEAF

WIRE STRIP LENGTH	INSULATION DIAMETER RANGE
3.58-4.34 mm [.141-.171 IN]	Ø 2.54 mm MAX [.100 IN MAX]

TERMINAL APPLICATION SPECIFICATION (A)114-1015 (B)114-1021

TERMINALS APPLIED

TE TERMINAL	TE TERMINAL	TE TERMINAL	TE TERMINAL
(A) 61668-1	(A) 1-61668-5	(B) 342664-2	(B) 737372-1
(A) 61668-2	(A) 3-61668-1	(B) 342664-3	(B) 737372-2
(A) 61668-4	(B) 342664-1	(B) 342664-4	

TERMINAL DATA: TE TERMINAL TE CRIMP SPECIFICATION

TERMINAL NAME: RECEPTACLE, SL-156

WIRE STRIP LENGTH	INSULATION DIAMETER RANGE
3.58-4.34 mm [.141-.171 IN]	Ø 1.09-2.79 mm [.043-.110 IN]

TERMINAL APPLICATION SPECIFICATION (B)114-1021

TERMINALS APPLIED

TE TERMINAL	TE TERMINAL	TE TERMINAL	TE TERMINAL
(B) 350980-2	(B) 3-350980-1	(B) 770476-1	(B) 3-647449-1
(B) 350980-3	(B) 640252-2	(B) 770476-2	
(B) 350980-4	(B) 640252-5	(B) 770476-3	
(B) 350980-5	(B) 3-640252-1	(B) 3-770476-1	

TERMINAL DATA: TE TERMINAL TE CRIMP SPECIFICATION

TERMINAL NAME: LID TYPE RECEPTACLE, SL-156

WIRE STRIP LENGTH	INSULATION DIAMETER RANGE
3.58-4.34 mm [.141-.171 IN]	Ø 1.78-2.84 mm [.070-.112 IN]

TERMINAL APPLICATION SPECIFICATION (B)114-1021

TERMINALS APPLIED

TE TERMINAL	TE TERMINAL	TE TERMINAL	TE TERMINAL
(B) 4-647406-1	(B) 3-647406-1	(B) 647406-2	

WIRE SIZE	CRIMP HEIGHT mm [INCH]	CRIMP HEIGHT REFERENCE SETTING
18 AWG	1.30+/-0.05 [.051+/- .002]	4.4
20 AWG	1.14+/-0.05 [.045+/- .002]	6.1
22 AWG	1.07+/-0.05 [.042+/- .002]	6.7
24 AWG	1.02+/-0.05 [.040+/- .002]	7.3

WIRE SIZE	CRIMP HEIGHT mm [INCH]	CRIMP HEIGHT REFERENCE SETTING
18 AWG	1.30+/-0.05 [.051+/- .002]	4.4
22AWG + 22AWG	1.22+/-0.05 [.048+/- .002]	5.3
20 AWG	1.14+/-0.05 [.045+/- .002]	6.1
22 AWG	1.07+/-0.05 [.042+/- .002]	6.7
24 AWG	1.02+/-0.05 [.040+/- .002]	7.3

WIRE SIZE	CRIMP HEIGHT mm [INCH]	CRIMP HEIGHT REFERENCE SETTING
18 AWG	1.30+/-0.05 [.051+/- .002]	4.4
20 AWG	1.14+/-0.05 [.045+/- .002]	6.1
22 AWG	1.07+/-0.05 [.042+/- .002]	6.7
24 AWG	1.02+/-0.05 [.040+/- .002]	7.3

- 1 RECOMMENDED SPARE PARTS
- 2 REFER TO SUPPLIED INSTRUCTION SHEET FOR CLEANING, LUBRICATION & STORAGE OF APPLICATOR.
- 3 APPLY PART NUMBER 1-23419-5 LOCTITE TO THREADS OF ITEM 180. APPLY PART NUMBER 2-23419-6 LOCTITE TO THREADS OF ITEM 242.
- 4 CRIMP HEIGHT REFERENCE SETTING WAS THE SETTING USED WHEN THE APPLICATOR WAS QUALIFIED AT THE FACTORY. ADJUSTMENT MAY BE NECESSARY WHEN RUNNING APPLICATOR IN THE FIELD.
- 5 TERMINAL LUBRICANT IS RECOMMENDED.
- 6 UNLESS SPECIFIED OTHERWISE TORQUE VALUES SHALL BE USED PER DOCUMENT, 101-35000.
- 7 22AWG + 22AWG WIRE COMBINATION TO ONLY BE USED WITH TERMINAL PN 3-647449-1.

***WARNING**
 ON INSTALLATION, SET WIRE DISC TO CRIMP HEIGHT REFERENCE SETTING FOR LARGEST WIRE SIZE. CRIMP HEIGHT REFERENCE SETTINGS GREATER THAN THE VALUE SHOWN MAY CAUSE DAMAGE TO THE CRIMP TOOLING, REFER TO THE INSTRUCTION SHEET FOR PROPER SETUP AND ADJUSTMENTS.

ATLANTIC VERSION
 Shown on sheets 1 of 4 & 2 of 4
 (Pacific version shown on sheets 3 of 4 & 4 of 4)

LOC	DIST	REV	DATE	BY	CHKD	APPD
A	66	F1	03AUG2018	KH	CT	
		F2	13SEP2018	TB	GB	
		G	22AUG2019	JAH	GB	
		H	03AUG2020	FZ	RK	

REV	DATE	BY	CHKD	APPD	DESCRIPTION	ITEM NO	
-	-	-	1	1	-	1803515-3 RAM ASSEMBLY, SF ATLANTIC	293
-	-	-	1	1	-	2-1803583-1 APPLICATOR BASIC ASSEMBLY, SF	292
-	1	-	1	-	1	2119641-1 FEED CAM, AIR FEED	248
-	1	1	1	1	1	2119082-4 CAM, SNAIL, INSULATION ADJUSTMENT	244
-	1	1	1	1	1	2079764-1 WASHER, WAVE SPRING, CREST-TO-CREST	243
-	1	1	1	1	1	2119083-1 RETAINER, INSULATION DIAL	242
-	1	1	1	1	1	7-18023-7 SCR, SKT HD CAP M3 X 4.0	241
-	-	1	-	1	-	2119580-1 MECHANICAL FEED ASSEMBLY	239
-	1	-	1	-	1	2844940-1 AIR FEED MODULE	238
-	-	-	1	1	-	4-1722335-3 STRIPPER, SIDE FEED	182
-	-	-	1	1	-	1-5018030-0 NUT, HEX, REG, RoHS, M3.5	181
-	-	-	1	1	-	2-1752354-0 STANDOFF,HOLD-DOWN	180
-	-	-	1	1	-	993111-1 PIN, SLOTTED SPRING 3.0 X 20.0	177
-	-	-	1	1	-	5-22280-0 SPRING, COMPRESSION	176
-	-	-	1	1	-	1752353-3 GUIDE PIN,HOLDDOWN	175
-	-	-	1	1	-	1901680-2 GUIDE PIN,HOLDDOWN	174
-	REF	REF	REF	REF	REF	994970-2 COUNTER, MAGNETIC	164
-	1	1	1	1	1	2119955-1 ASSY, LUBRICATOR, SIDE FEED	113
-	1	1	1	1	1	2844908-1 SCREW, LOCKING	99
-	1	1	1	1	1	2844907-1 POST, LOCKING	98
-	1	1	1	1	1	455888-4 SPACER, CRIMPER	82
-	1	1	1	1	1	1803607-3 DOCUMENTATION PACKAGE	71
-	1	1	1	1	1	2119791-9 DEPRESSOR, WIRE	70
-	1	1	1	1	1	2119740-1 TAG, IDENTIFICATION	67
-	2	2	2	2	2	2168078-1 SCREW, DRIVE, RH, RoHS, 2 x .188	66
-	1	1	1	1	1	2168083-2 SCR, SKT HD CAP, RoHS, M4 X 8.0	60
-	1	1	1	1	1	5-18022-5 SCR, HEX HD CAP, M4 X 6.0	59
-	1	1	1	1	1	1338685-1 PAWL, FEED	56
-	4	4	4	4	4	2168083-3 SCR, SKT HD CAP, RoHS, M4 X 12.0	54
-	2	2	2	2	2	1-2168083-0 SCR, SKT HD CAP, RoHS, M4 X 10	53
-	1	1	1	1	1	5018030-1 NUT, HEX, REG, RoHS, M3	52
-	1	1	1	1	1	811242-5 BUMPER, HOLD DOWN	51
-	1	1	1	1	1	690753-2 SPACER, TONKER	50
-	1	2	1	2	1	18023-9 SCR, SKT HD CAP M4 X 6.0	49
-	-	1	-	1	-	2119652-1 FEED CAM, PRE FEED	48
-	-	1	-	1	-	2119653-1 FEED CAM, POST FEED	47
-	1	1	-	-	1	1803583-9 APPLICATOR BASIC ASSEMBLY, SF	46
-	1	1	-	-	1	1803515-1 RAM ASSEMBLY, SF ATLANTIC	44
-	1	1	1	1	1	1803602-1 SCR, BHSC, RoHS (M8 X 25)	41
-	1	1	1	1	1	1752356-1 SUPPORT, TERMINAL	34
-	2	2	2	2	2	2079383-5 SCR, BHSC, RoHS (M4 X 20)	33
-	2	2	2	2	2	2-2844962-6 SPACER, CYLINDRICAL, STRIP GUIDE	30
-	1	1	1	1	1	2844992-1 ASSEMBLY, STRIP GUIDE	29
-	1	1	1	1	1	455888-3 SPACER, CRIMPER	28
-	1	1	1	1	1	1320928-2 STRIP GUIDE	24
-	1	1	-	-	1	2168083-2 SCR, SKT HD CAP, RoHS, M4 X 8.0	21
-	2	2	1	1	2	1-18028-2 WASHER, FLAT, REG M4	20
-	1	1	-	-	1	2119533-1 STRIPPER, SIDE FEED	19
-	1	1	1	1	1	2119806-1 INSERT, SHEAR	13
-	1	1	1	1	1	3-22280-3 SPRING, COMPRESSION	12
-	1	1	1	1	1	1-356885-4 STOP, SHEAR	11
-	1	1	1	1	1	2119805-1 SHEAR HOLDER, FRONT	10
-	1	1	1	1	1	1803095-6 FLOATING SHEAR, FRONT	9
1	2	2	1	1	1	4-1633139-4 ANVIL, COMBINATION	8
-	1	1	1	1	1	1-240641-7 SPACER	7
-	1	1	1	1	1	2119757-2 DEPRESSOR, SHEAR	5
-	1	1	1	1	1	2-238011-2 BLOCK, CRIMPER SPACER	4
1	2	2	1	1	1	1-1803260-4 CRIMPER, INSULATION F PREMIUM	3
-	1	1	1	1	1	455888-2 SPACER, CRIMPER	2
1	2	2	1	1	1	4-456404-4 CRIMPER, WIRE PREMIUM	1

REV	DATE	BY	CHKD	APPD	DESCRIPTION	ITEM NO			
-77	-72	-71	-52	-51	-2	-1	PART NO	DESCRIPTION	ITEM NO

TE Connectivity
 Harrisburg, PA 17105-3608

Ocean Side Feed
 Applicator

Customer Accessible Production Drawing SCALE 1:2 SHEET 1 OF 4 REV H

LOC		DIST		REVISIONS			
A	66	P	LTN	DESCRIPTION	DATE	DWN	APVD
		-		SEE SHEET 1			

FEED TYPE MECHANICAL

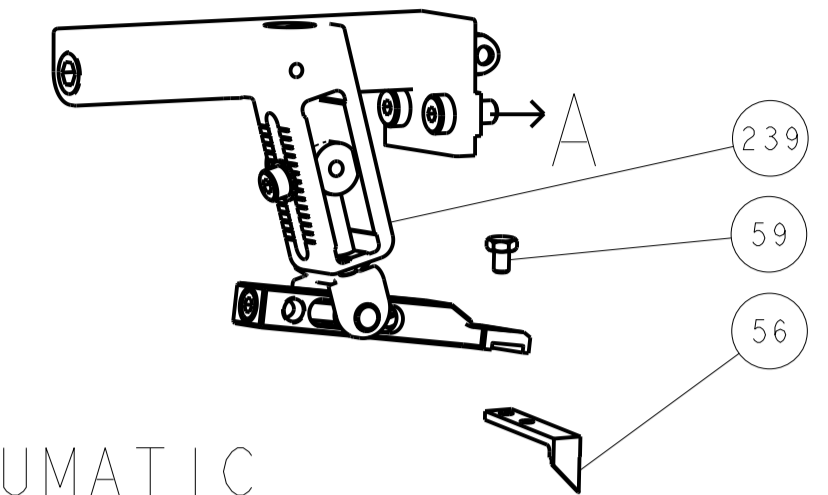

PNEUMATIC

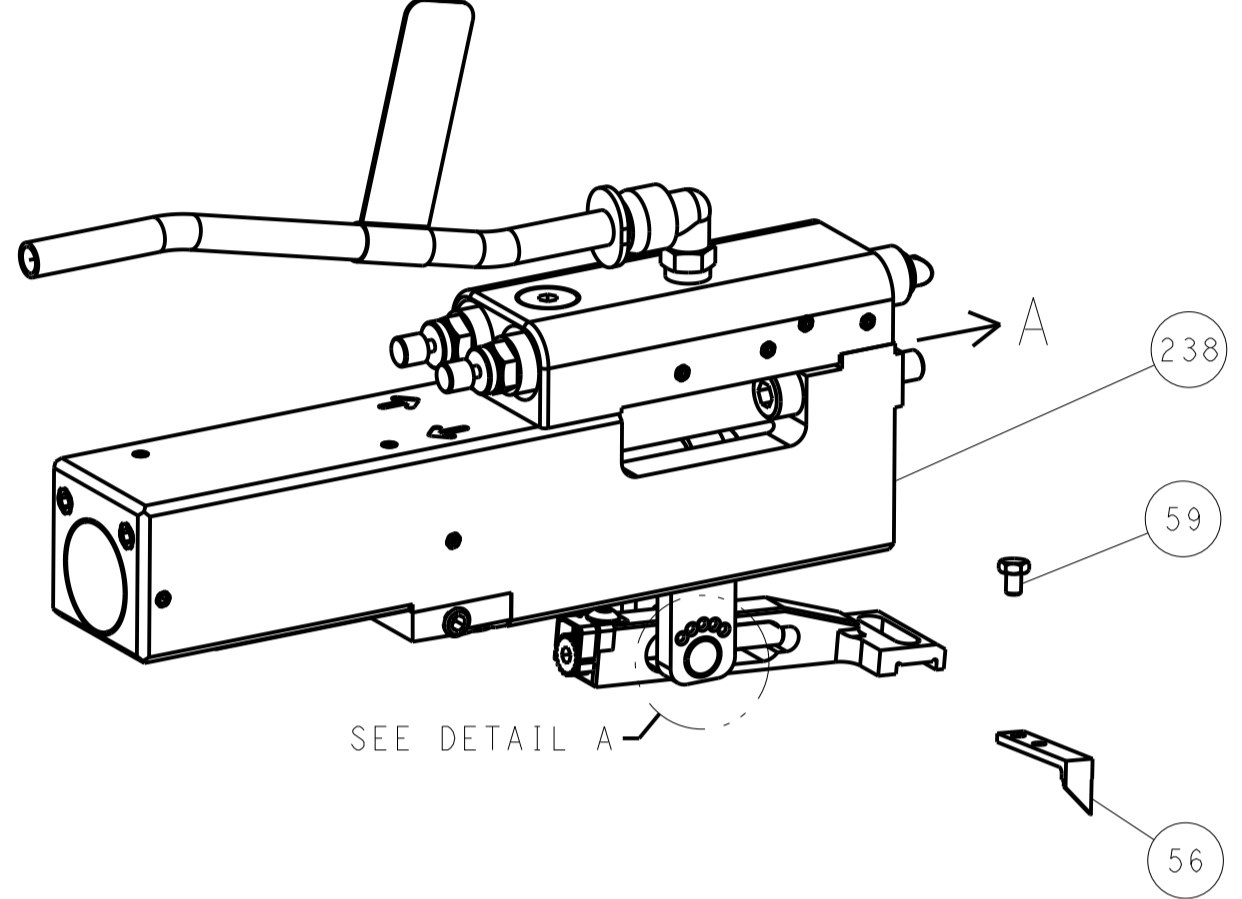

FEED SPRING SETTING POSITION (SHOWN FROM REAR SIDE)

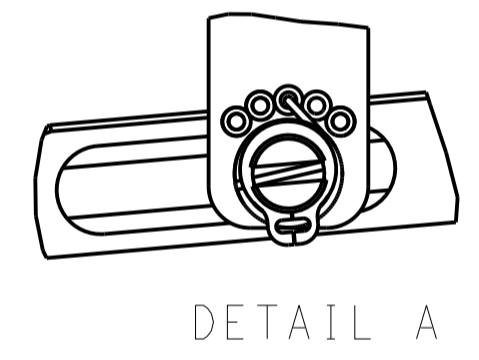

DETAIL A

CAM POSITIONS

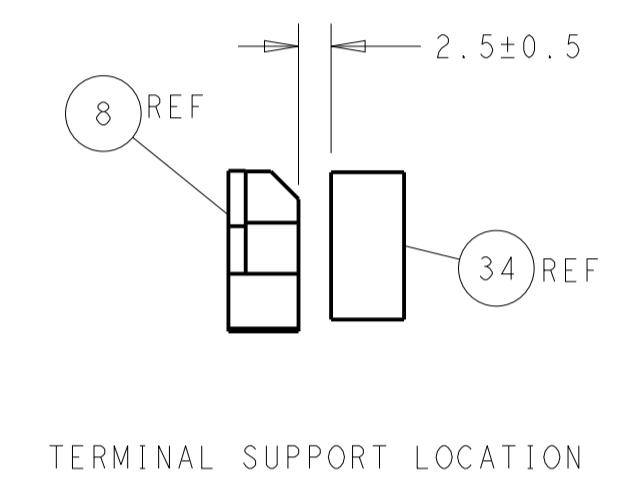
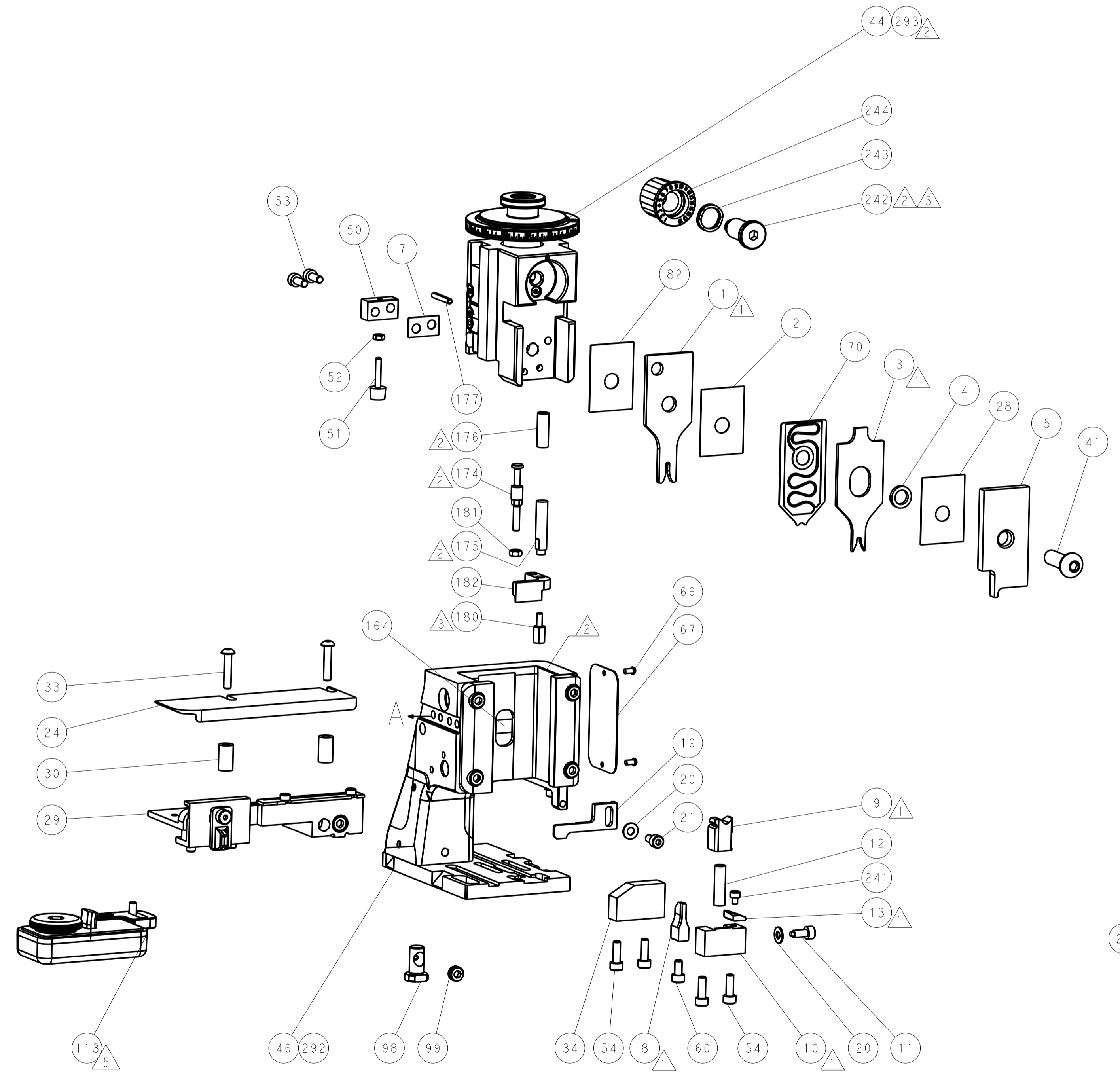
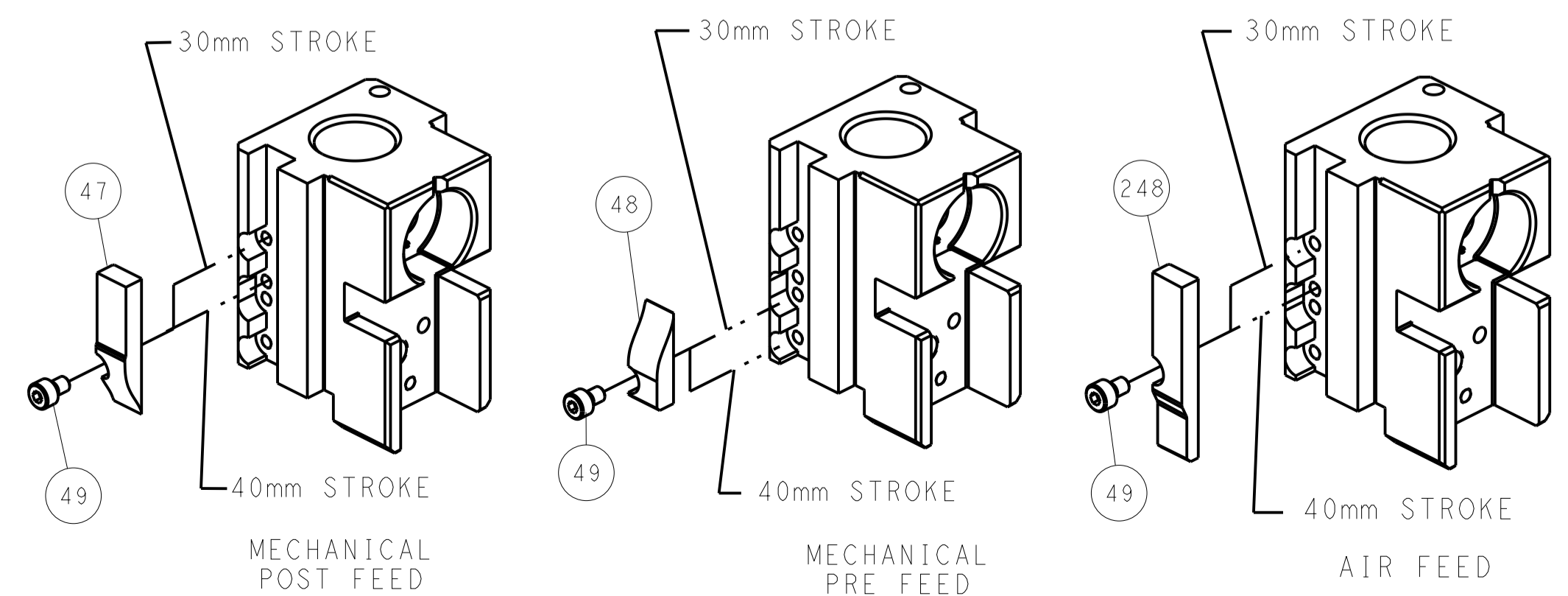

TERMINAL SUPPORT LOCATION

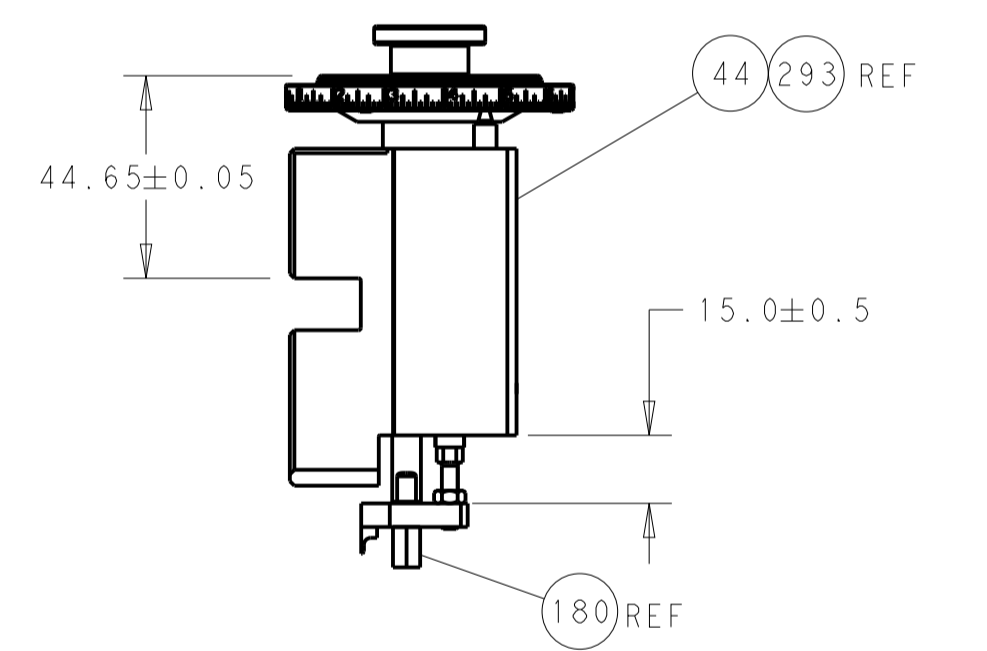

RAM & HOLD DOWN SET-UP

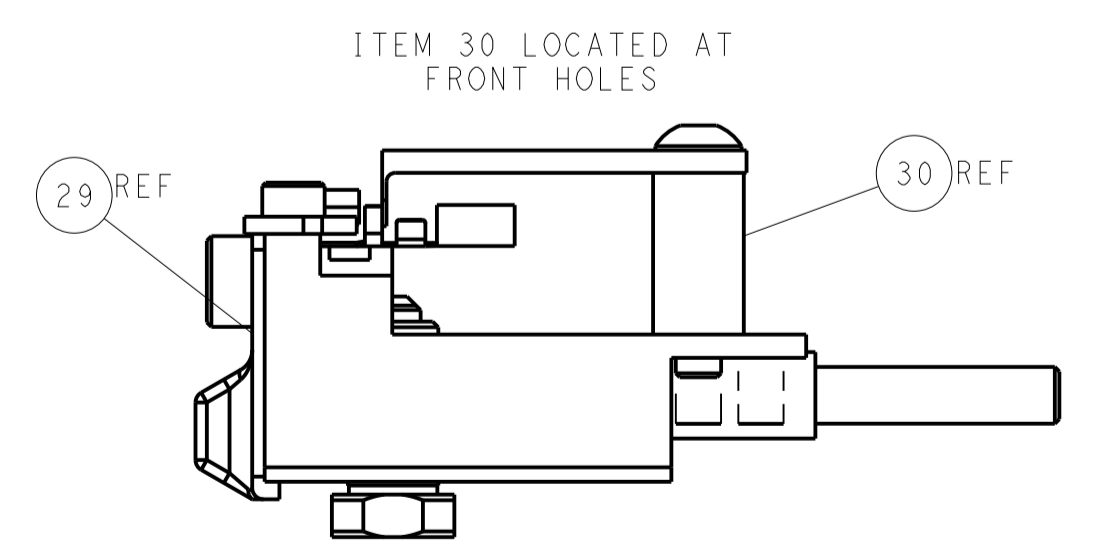

FEED TRACK POSITION GUIDE BY INSULATION BARREL

ATLANTIC VERSION
 Shown on sheets 1 of 4 & 2 of 4
 (Pacific version shown on sheets 3 of 4 & 4 of 4)

DIMENSIONS:		TOLERANCES UNLESS OTHERWISE SPECIFIED:		DWN C. MOYER 01NOV2011		TE Connectivity	
mm	0 PLC ±	1 PLC ±	2 PLC ±	3 PLC ±	4 PLC ±	Harrisburg, PA 17105-3608	
MATERIAL:		FINISH:		APVD T. ELBIN 01NOV2011		NAME Ocean Side Feed Applicator	
Customer Accessible Production Drawing		SCALE 1:2		SHEET 2 OF 4		REV H	

PART NUMBER	REVISION	DESCRIPTION	FEED TYPE
2-2151033-1	G	FINE CRIMP HEIGHT ADJUST	MECHANICAL
2-2151033-2	H	FINE CRIMP HEIGHT ADJUST	PNEUMATIC
7-2151033-7	G	CRIMP TOOLING KIT	-

PACIFIC VERSION TERMINATOR
INTERFACE ADAPTER

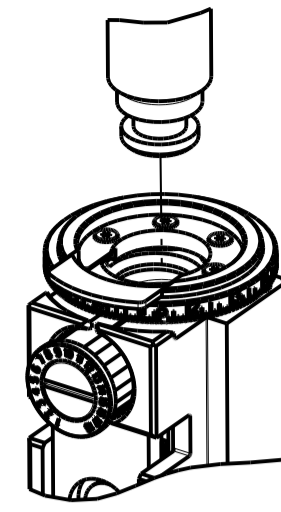

APPLICATOR DATA		
CRIMP	SIZE	TYPE
WIRE	1.78 mm [.070]	F
INSUL	2.54 mm [.100]	F

APPLICATOR INSTRUCTIONS
408-35042

TERMINAL DATA: TE TERMINAL		TE CRIMP SPECIFICATION	
TERMINAL NAME: CONTACT, BIFURCATED LEAF			
WIRE STRIP LENGTH		INSULATION DIAMETER RANGE	
3.58-4.34 mm [.141-.171 IN]		∅ 1.91-2.54 mm [.075-.100 IN]	
TERMINAL APPLICATION SPECIFICATION	(A)114-1015	-	-
	(B)114-1021	-	-
TERMINALS APPLIED ⁵			
TE TERMINAL	TE TERMINAL	TE TERMINAL	TE TERMINAL
(A) 61668-1	(A) 1-61668-5	(B) 342664-2	(B) 737372-1
(A) 61668-2	(A) 3-61668-1	(B) 342664-3	(B) 737372-2
(A) 61668-4	(B) 342664-1	(B) 342664-4	

TERMINAL DATA: TE TERMINAL		TE CRIMP SPECIFICATION	
TERMINAL NAME: RECEPTACLE, SL-156			
WIRE STRIP LENGTH		INSULATION DIAMETER RANGE	
3.58-4.34 mm [.141-.171 IN]		∅ 1.09-2.79 mm [.043-.110 IN]	
TERMINAL APPLICATION SPECIFICATION	(B)114-1021	-	-
TERMINALS APPLIED ⁵			
TE TERMINAL	TE TERMINAL	TE TERMINAL	TE TERMINAL
(B) 350980-2	(B) 3-350980-1	(B) 770476-1	(B) 3-647449-1
(B) 350980-3	(B) 640252-2	(B) 770476-2	
(B) 350980-4	(B) 640252-5	(B) 770476-3	
(B) 350980-5	(B) 3-640252-1	(B) 3-770476-1	

TERMINAL DATA: TE TERMINAL		TE CRIMP SPECIFICATION	
TERMINAL NAME: LID TYPE RECEPTACLE, SL-156			
WIRE STRIP LENGTH		INSULATION DIAMETER RANGE	
3.58-4.34 mm [.141-.171 IN]		∅ 1.78-2.84 mm [.070-.112 IN]	
TERMINAL APPLICATION SPECIFICATION	(B)114-1021	-	-
TERMINALS APPLIED ⁵			
TE TERMINAL	TE TERMINAL	TE TERMINAL	TE TERMINAL
(B) 4-647406-1	(B) 3-647406-1	(B) 647406-2	

WIRE SIZE	CRIMP HEIGHT mm [INCH]	CRIMP HEIGHT REFERENCE SETTING
18 AWG	1.30+/-0.05 [.051+/- .002]	4.4
20 AWG	1.14+/-0.05 [.045+/- .002]	6.1
22 AWG	1.07+/-0.05 [.042+/- .002]	6.7
24 AWG	1.02+/-0.05 [.040+/- .002]	7.3

WIRE SIZE	CRIMP HEIGHT mm [INCH]	CRIMP HEIGHT REFERENCE SETTING
18 AWG	1.30+/-0.05 [.051+/- .002]	4.4
⁷ 22AWG + 22AWG	1.22+/-0.05 [.048+/- .002]	5.3
20 AWG	1.14+/-0.05 [.045+/- .002]	6.1
22 AWG	1.07+/-0.05 [.042+/- .002]	6.7
24 AWG	1.02+/-0.05 [.040+/- .002]	7.3

WIRE SIZE	CRIMP HEIGHT mm [INCH]	CRIMP HEIGHT REFERENCE SETTING
18 AWG	1.30+/-0.05 [.051+/- .002]	4.4
20 AWG	1.14+/-0.05 [.045+/- .002]	6.1
22 AWG	1.07+/-0.05 [.042+/- .002]	6.7
24 AWG	1.02+/-0.05 [.040+/- .002]	7.3

- RECOMMENDED SPARE PARTS
- REFER TO SUPPLIED INSTRUCTION SHEET FOR CLEANING, LUBRICATION & STORAGE OF APPLICATOR.
- APPLY PART NUMBER 2-23419-6 LOCTITE TO THREADS OF ITEM 242.
- CRIMP HEIGHT REFERENCE SETTING WAS THE SETTING USED WHEN THE APPLICATOR WAS QUALIFIED AT THE FACTORY. ADJUSTMENT MAY BE NECESSARY WHEN RUNNING APPLICATOR IN THE FIELD.
- TERMINAL LUBRICANT IS RECOMMENDED.
- 6. UNLESS SPECIFIED OTHERWISE TORQUE VALUES SHALL BE USED PER DOCUMENT, 101-35000.
- 22AWG + 22AWG WIRE COMBINATION TO ONLY BE USED WITH TERMINAL PN 3-647449-1.

***WARNING**
ON INSTALLATION, SET WIRE DISC TO CRIMP HEIGHT REFERENCE SETTING FOR LARGEST WIRE SIZE. CRIMP HEIGHT REFERENCE SETTINGS GREATER THAN THE VALUE SHOWN MAY CAUSE DAMAGE TO THE CRIMP TOOLING, REFER TO THE INSTRUCTION SHEET FOR PROPER SETUP AND ADJUSTMENTS.

PACIFIC VERSION
Shown on sheets 3 of 4 & 4 of 4
(Atlantic version shown on sheets 1 of 4 & 2 of 4)

LOC	DIST	REV	DATE	BY	APPV
A	66				

		REVISONS		DATE	BY	APPV
REF	DESCRIPTION	DATE	BY	APPV		
-	SEE SHEET 1	-	-	-	-	-
-	1	1	2119082-4	CAM, SNAIL, INSULATION ADJUSTMENT		244
-	1	1	2079764-1	WASHER, WAVE SPRING, CREST-TO-CREST		243
	1	1	2119083-1	RETAINER, INSULATION DIAL		242
-	1	1	7-18023-7	SCR, SKT HD CAP M3 X 4.0		241
-	-	1	2119580-1	MECHANICAL FEED ASSEMBLY		239
-	1	-	2844940-1	AIR FEED MODULE		238
-	REF	REF	994970-2	COUNTER, MAGNETIC		164
-	1	-	2119641-2	FEED CAM, AIR FEED		151
-	1	1	2168083-8	SCR, SKT HD CAP, RoHS, M4 X 16		144
-	4	4	2168083-9	SCR, SKT HD CAP, RoHS, M4 X 20		143
-	-	1	2119653-2	FEED CAM, POST FEED		142
-	1	1	1-1803583-0	APPLICATOR BASIC ASSEMBLY, SF		141
	1	1	1803516-1	RAM ASSEMBLY, SF PACIFIC		140
-	1	1	2119955-1	ASSY, LUBRICATOR, SIDE FEED		113
-	1	1	2844908-1	SCREW, LOCKING		99
-	1	1	2844907-1	POST, LOCKING		98
-	1	1	455888-4	SPACER, CRIMPER		82
-	1	1	1803607-3	DOCUMENTATION PACKAGE		71
-	1	1	2119791-9	DEPRESSOR, WIRE		70
-	1	1	2119740-1	TAG, IDENTIFICATION		67
-	2	2	2168078-1	SCREW, DRIVE, RH, RoHS, 2 x .188		66
-	1	1	5-18022-5	SCR, HEX HD CAP, M4 X 6.0		59
-	1	1	1338685-1	PAWL, FEED		56
-	2	2	1-2168083-0	SCR, SKT HD CAP, RoHS, M4 X 10		53
-	1	1	5018030-1	NUT, HEX, REG, RoHS, M3		52
-	1	1	811242-5	BUMPER, HOLD DOWN		51
-	1	1	690753-2	SPACER, TONKER		50
-	1	2	18023-9	SCR, SKT HD CAP M4 X 6.0		49
-	-	1	2119652-1	FEED CAM, PRE FEED		48
-	1	1	1803602-1	SCR, BHSC, RoHS (M8 X 25)		41
-	1	1	1752356-1	SUPPORT, TERMINAL		34
-	2	2	2079383-5	SCR, BHSC, RoHS (M4 X 20)		33
-	2	2	2-2844962-6	SPACER, CYLINDRICAL, STRIP GUIDE		30
-	1	1	2844992-1	ASSEMBLY, STRIP GUIDE		29
-	1	1	455888-3	SPACER, CRIMPER		28
-	1	1	1320928-2	STRIP GUIDE		24
-	1	1	2168083-2	SCR, SKT HD CAP, RoHS, M4 X 8.0		21
-	2	2	1-18028-2	WASHER, FLAT, REG M4		20
-	1	1	2119533-1	STRIPPER, SIDE FEED		19
	1	1	2119806-1	INSERT, SHEAR		13
-	1	1	3-22280-3	SPRING, COMPRESSION		12
-	1	1	1-356885-4	STOP, SHEAR		11
	1	1	2119805-1	SHEAR HOLDER, FRONT		10
	1	1	1803095-6	FLOATING SHEAR, FRONT		9
	1	1	4-1633139-4	ANVIL, COMBINATION		8
-	1	1	1-240641-7	SPACER		7
-	1	1	2119757-2	DEPRESSOR, SHEAR		5
-	1	1	2-238011-2	BLOCK, CRIMPER SPACER		4
	1	1	1-1803260-4	CRIMPER, INSULATION F PREMIUM		3
-	1	1	455888-2	SPACER, CRIMPER		2
	1	1	4-456404-4	CRIMPER, WIRE PREMIUM		1

DIMENSIONS:		TOLERANCES UNLESS OTHERWISE SPECIFIED:		MATERIAL:		FINISH:		WEIGHT:		SCALE:		SHEET:		REV:	
mm	0 PLC ±	1 PLC ±	2 PLC ±	3 PLC ±	4 PLC ±	ANGLES					1:2	3	4		H

LOC		DIST		REVISIONS			
A	66	P	LTM	DESCRIPTION	DATE	DWN	APVD
		-	-	SEE SHEET 1	-	-	-

FEED TYPE MECHANICAL

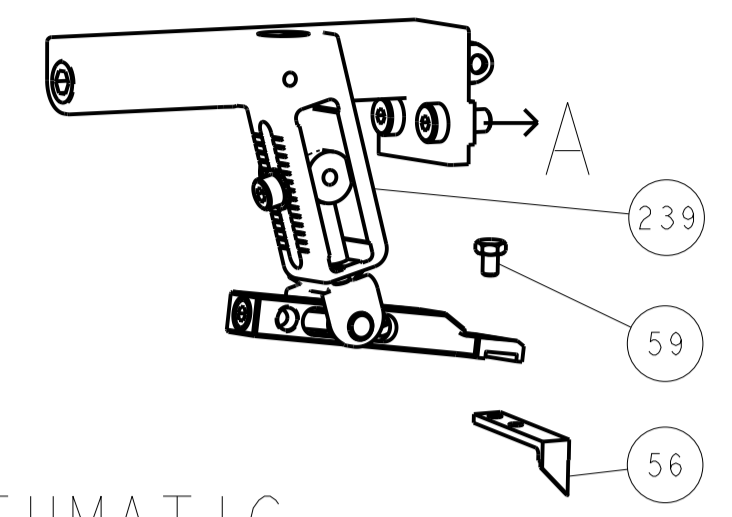

PNEUMATIC

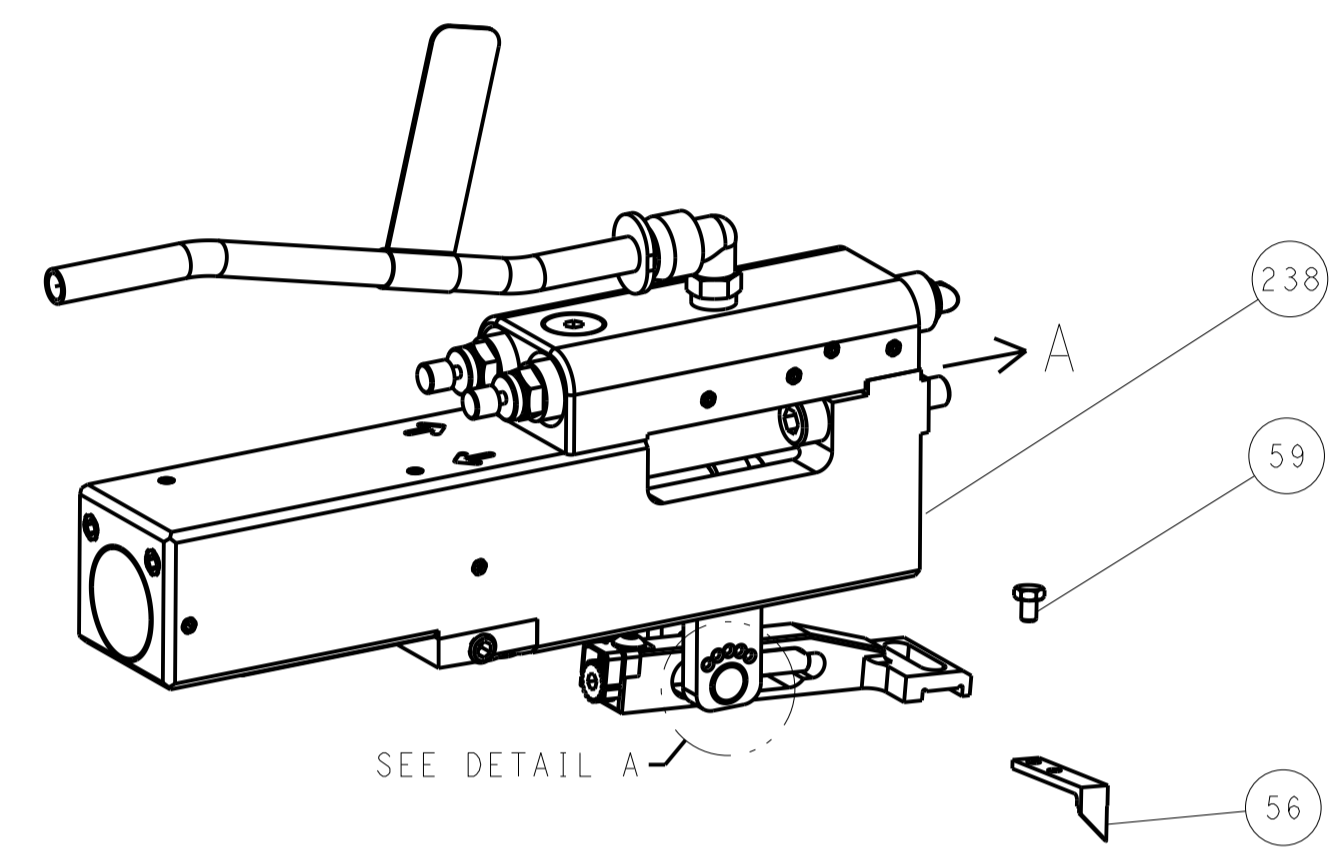

FEED SPRING SETTING POSITION (SHOWN FROM REAR SIDE)

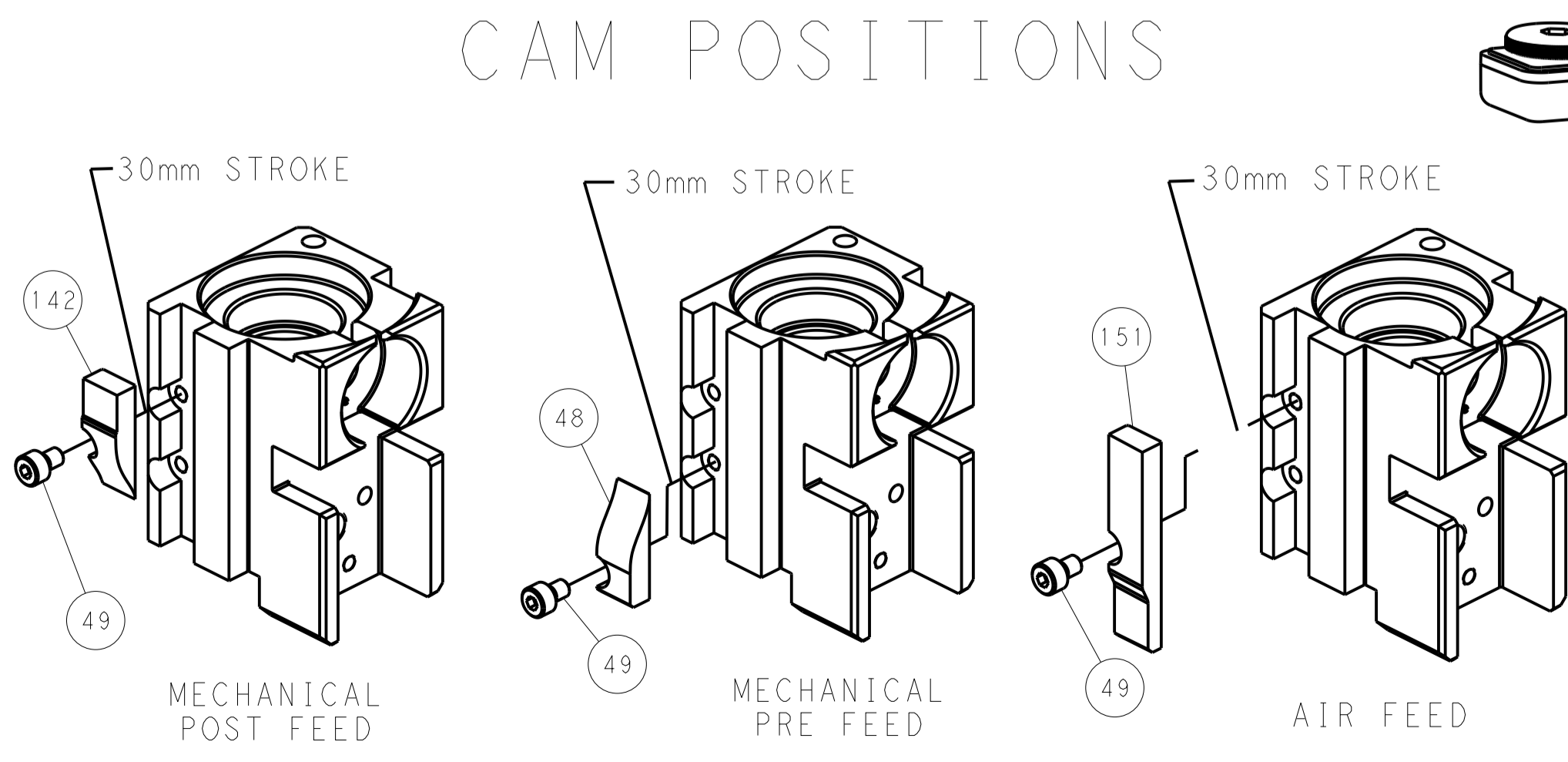
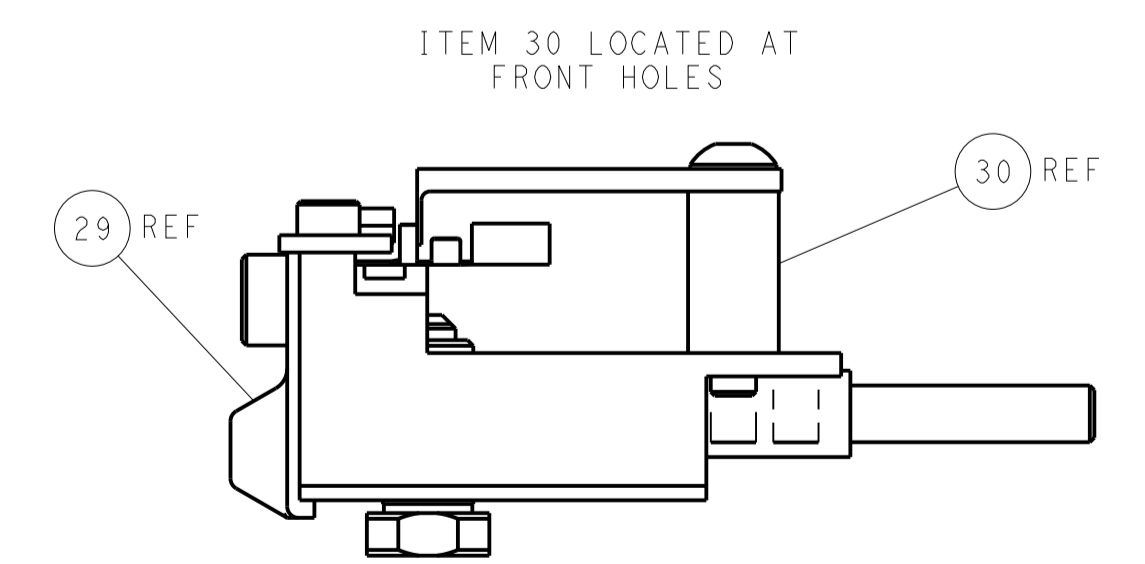
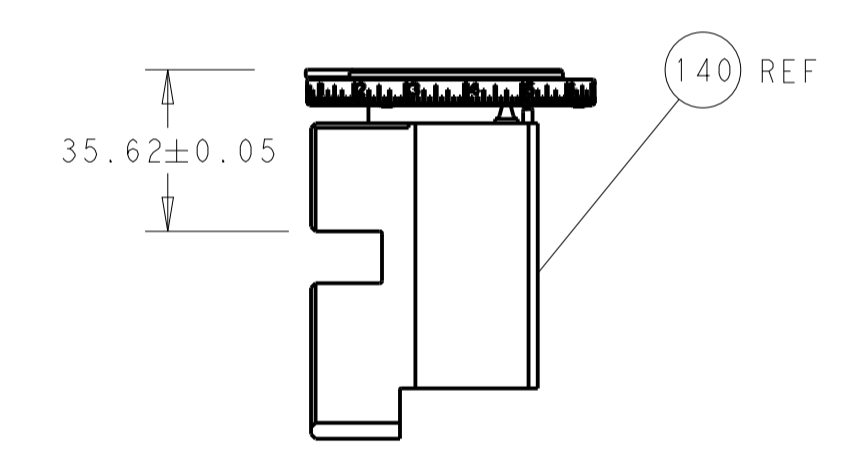
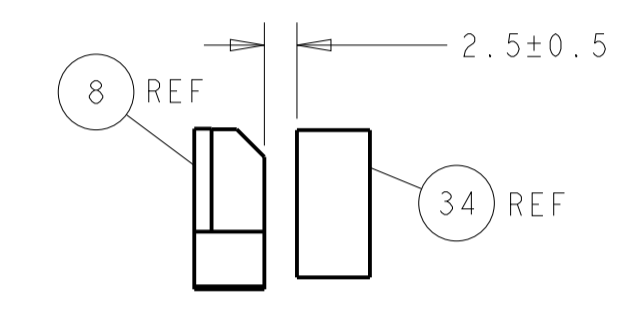
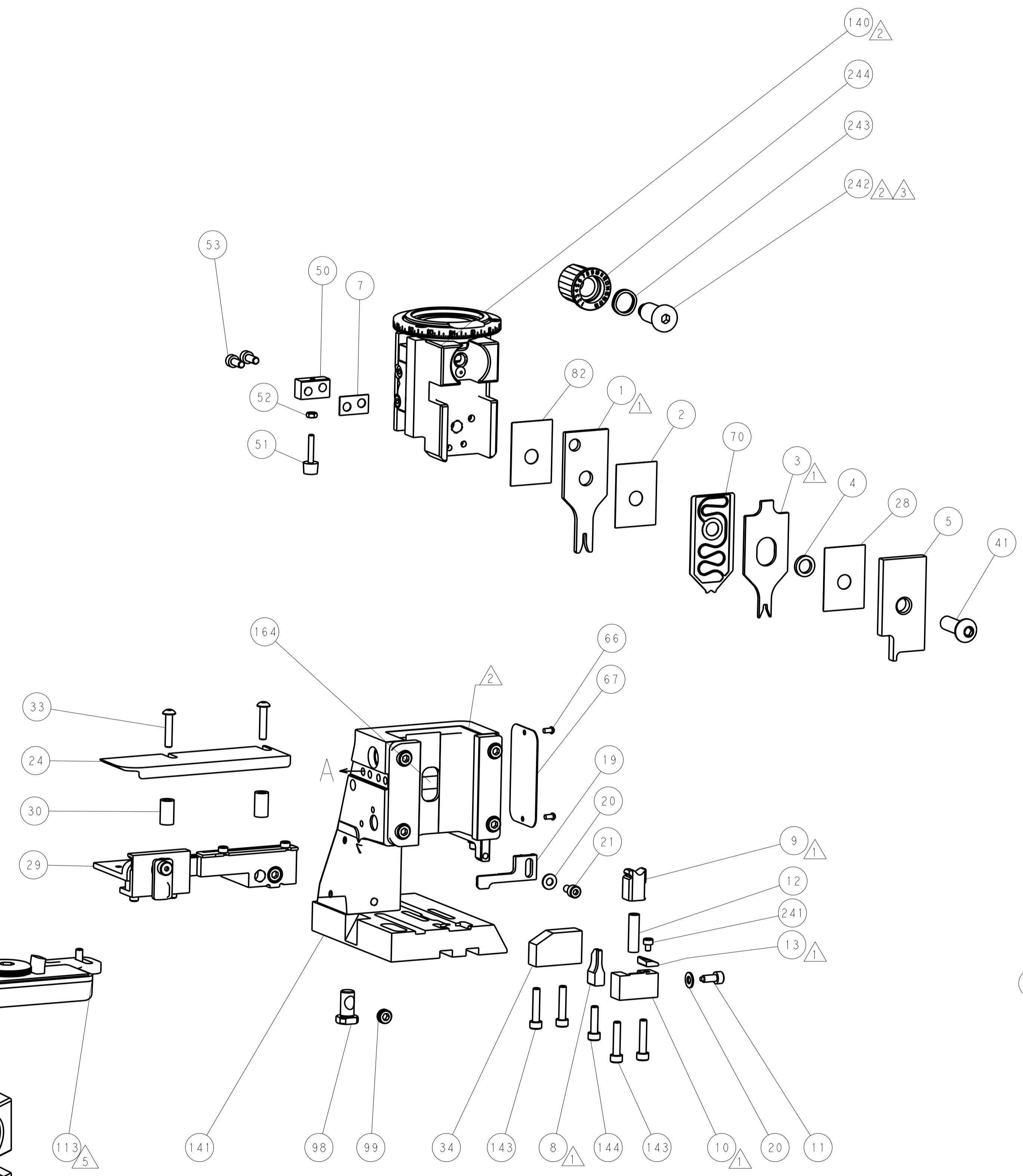
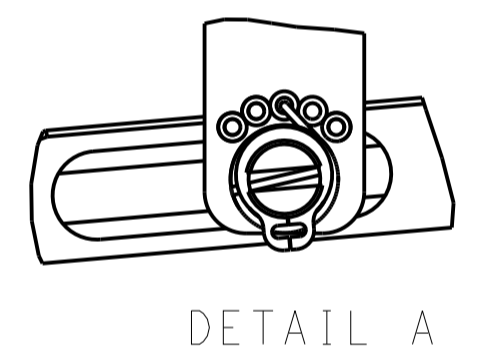

PACIFIC VERSION
 Shown on sheets 3 of 4 & 4 of 4
 (Atlantic version shown on sheets 1 of 4 & 2 of 4)

DIMENSIONS:		TOLERANCES UNLESS OTHERWISE SPECIFIED:		DWN C. MOYER 01NOV2011		TE Connectivity	
mm	0 PLC ±	1 PLC ±	2 PLC ±	3 PLC ±	4 PLC ±	Harrisburg, PA 17105-3608	
MATERIAL:		FINISH:		APVD T. ELBIN 01NOV2011		NAME	
				PRODUCT SPEC		Ocean Side Feed Applier	
				APPLICATION SPEC		SIZE CAGE CODE DRAWING NO	
				WEIGHT		A 00779 C=2151033	
				ANGLES		RESTRICTED TO	
				Customer Accessible Production Drawing		SCALE 1:2 SHEET 4 OF 4 REV H	

X-ON Electronics

Largest Supplier of Electrical and Electronic Components

Click to view similar products for [Crimpers / Crimping Tools](#) category:

Click to view products by [TE Connectivity](#) manufacturer:

Other Similar products are found below :

[010-0096](#) [M225201-06](#) [M225202-37](#) [6-1579015-5](#) [622-6441LF](#) [M322](#) [6-304052-1](#) [63456-0054](#) [63484-3701](#) [63800-8355](#) [63819-1875](#)
[63819-2875](#) [63819-4475](#) [63823-3475](#) [63827-5375](#) [64001-0975](#) [64001-4175](#) [64005-0175](#) [662903-2](#) [690602-6](#) [7-1579001-9](#) [7-23471-1](#)
[762637-1](#) [808714-1](#) [811242-5](#) [999-50-020083](#) [1-21002-3](#) [1-21002-7](#) [12085270](#) [1-21002-6](#) [1-21113-6](#) [1-22548-4](#) [125442-1](#)
[DCE.91.073.BVC](#) [DCE.91.090.3MVM](#) [DCE.91.130.5MVU](#) [DCE.91.202.BVCM](#) [1338300-1](#) [1-354003-0](#) [1338301-1](#) [DF62/RE-MD](#) [142321](#)
[1456088-1](#) [1490794-1](#) [1-45804-6](#) [1490357-2](#) [1490357-3](#) [AX100749](#) [1-59619-7](#) [1596970-1](#)